

2011 Tundra EWD  
EM16G0U

# System Circuit

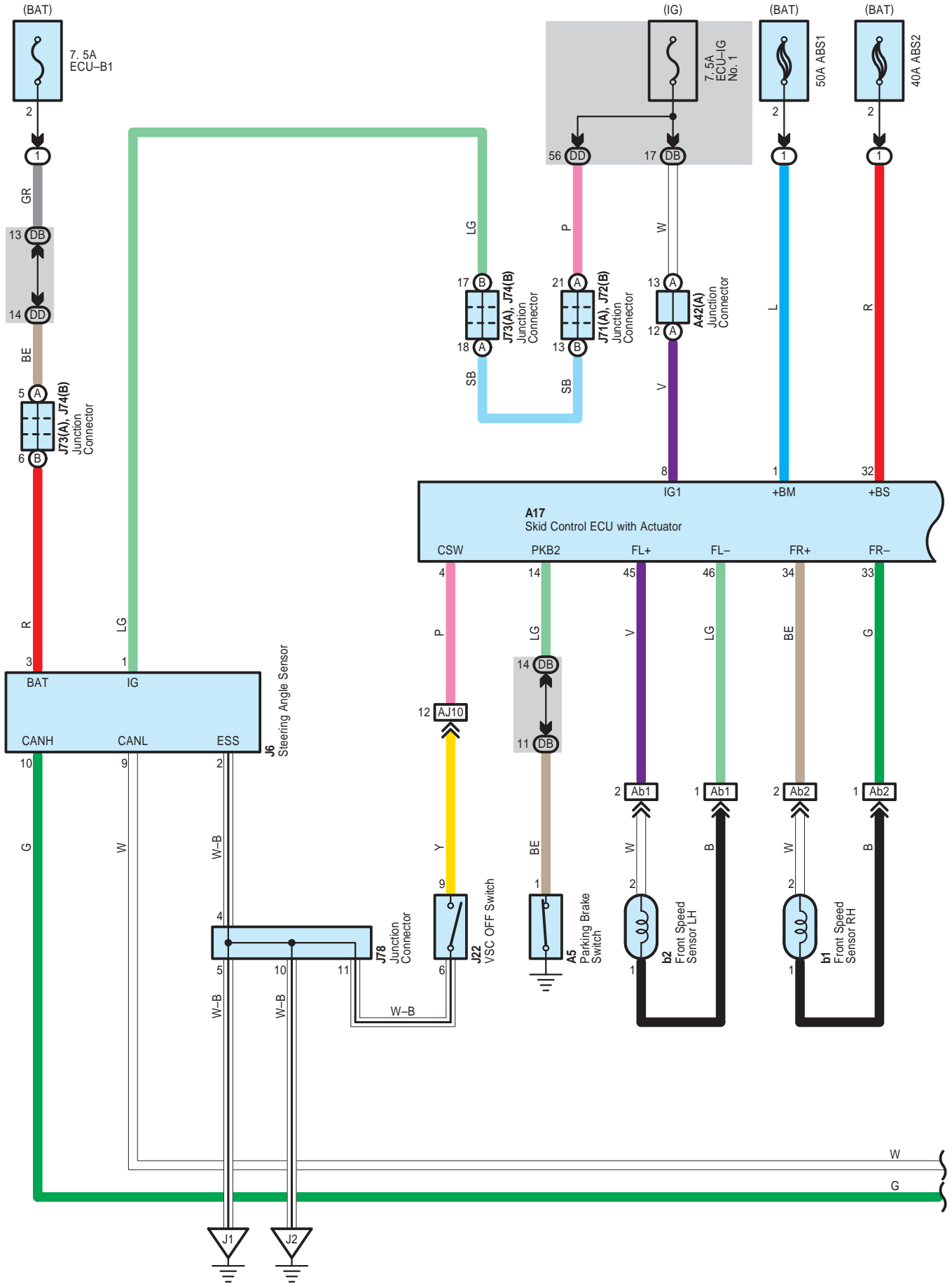

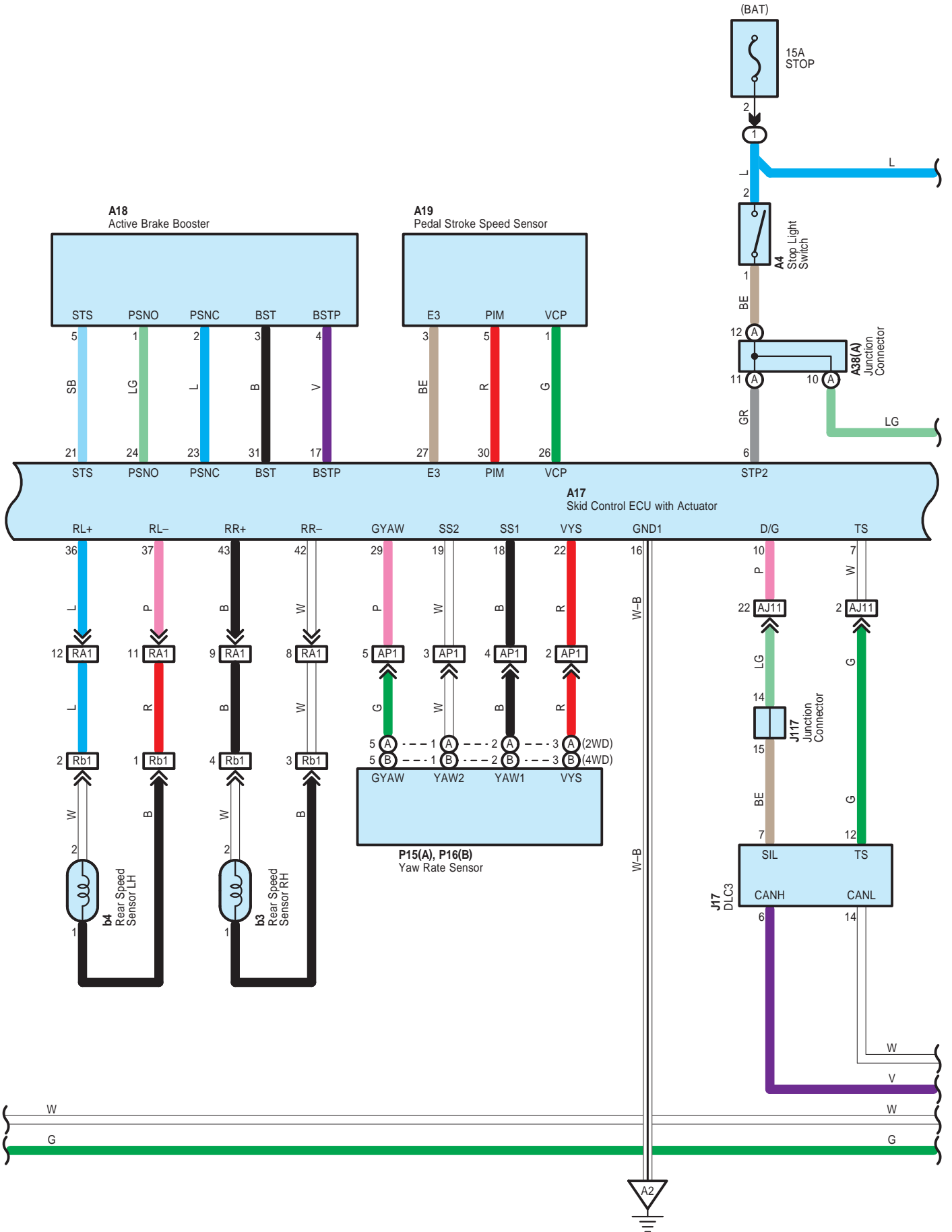



\* 1 : Except 1GR-FE

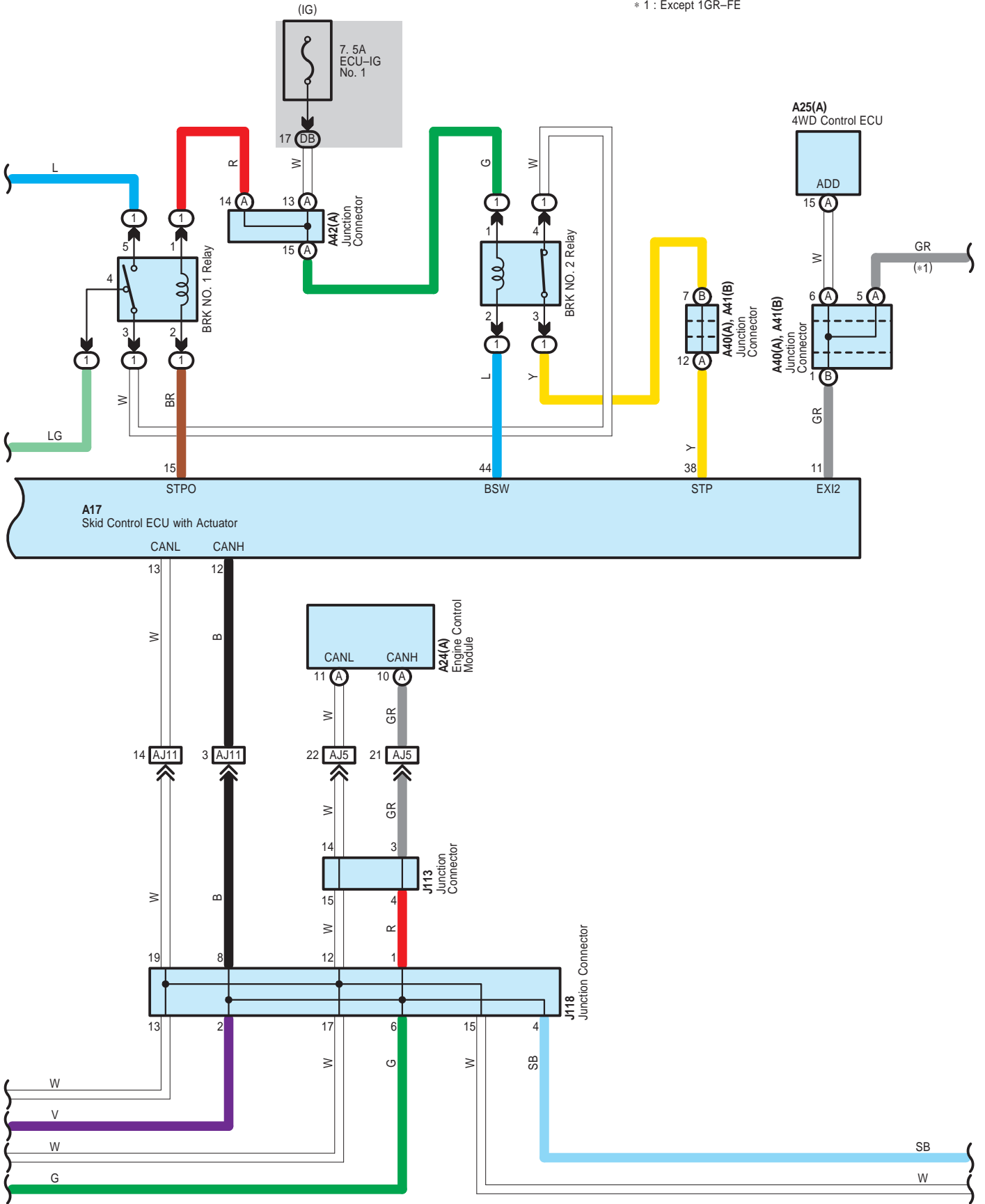

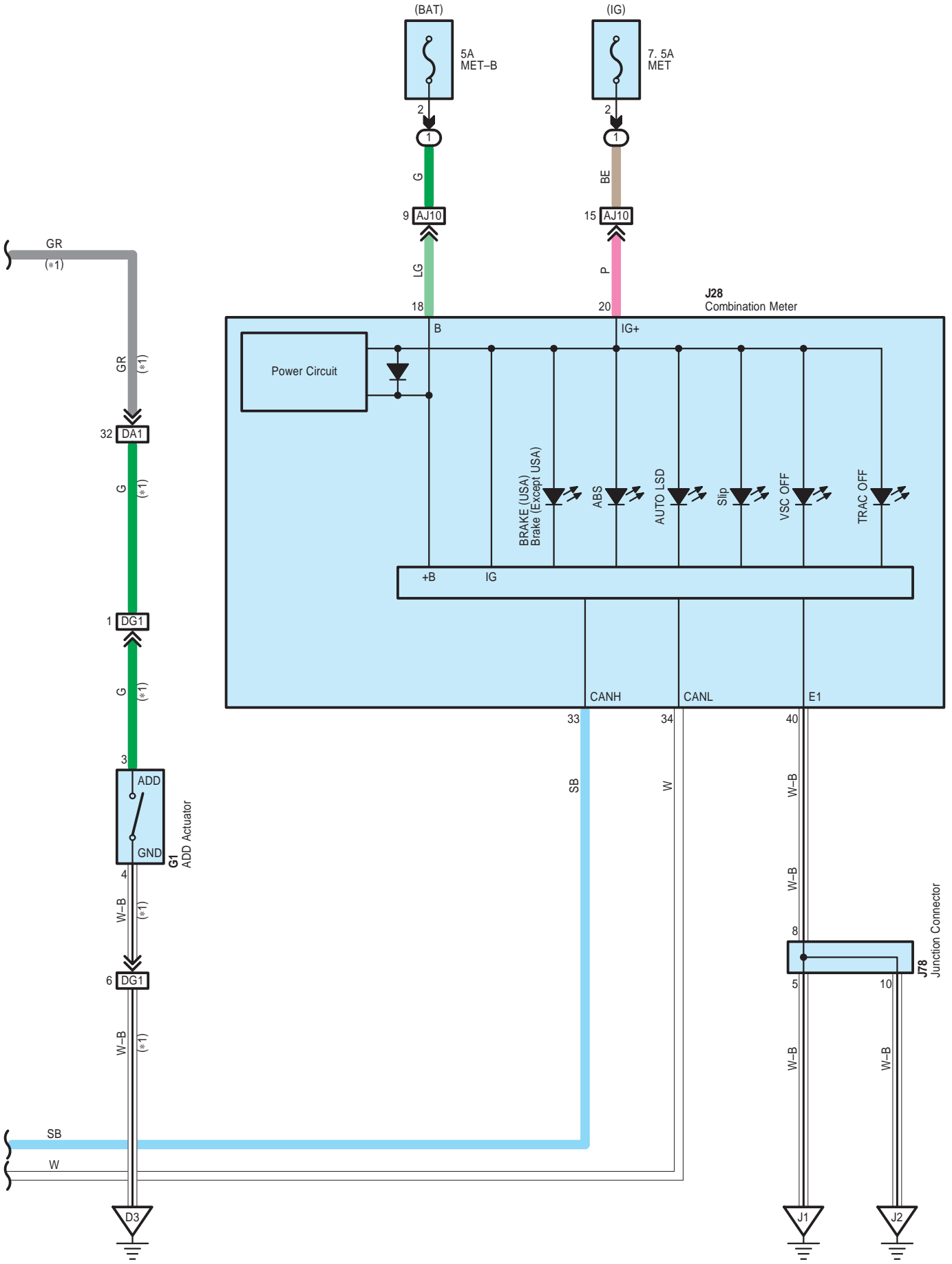

A 4

Blue

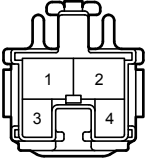

A 5

White



A 17

Black

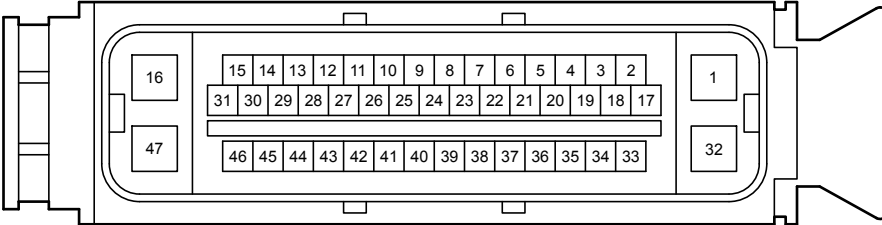

A 18

Black

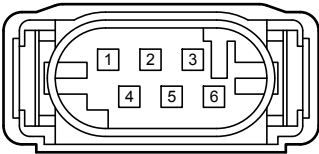

A 19

Black

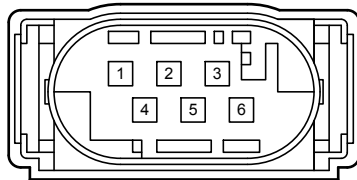

A 24

Black

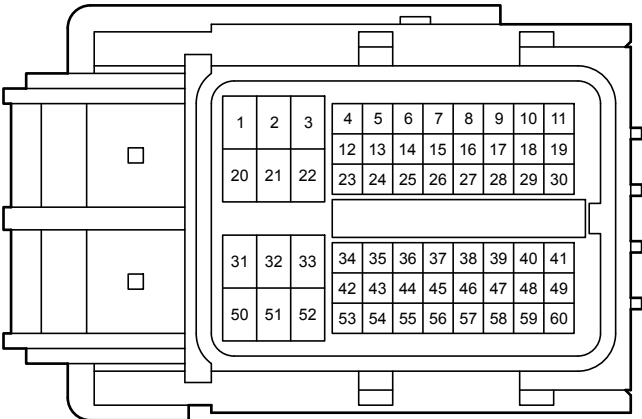

A 25

Black

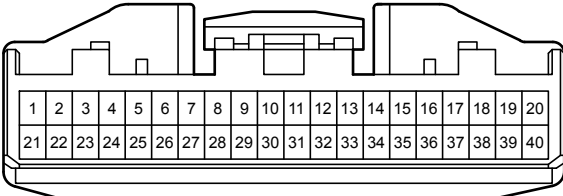

A 38

White

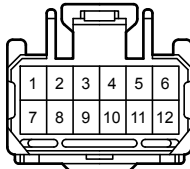

A 40

White

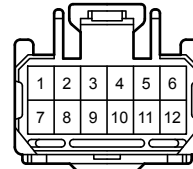

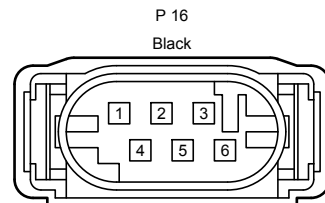
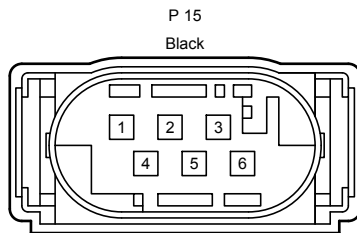
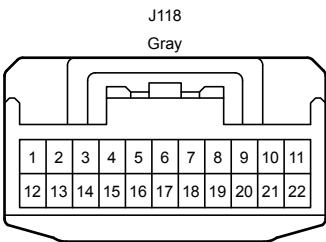
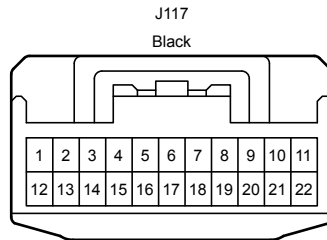
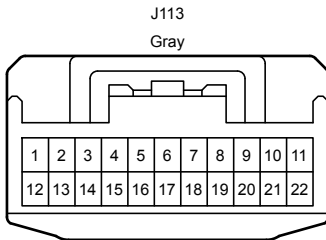
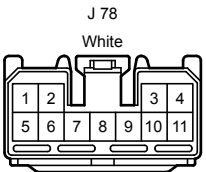
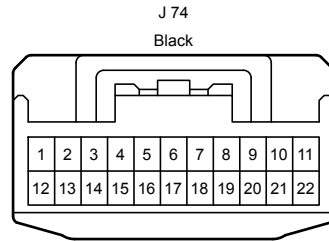
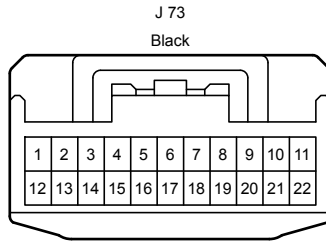
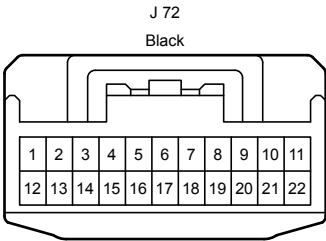
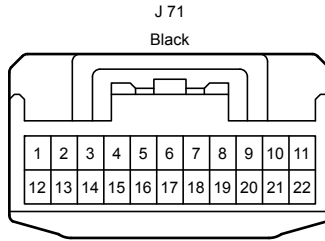
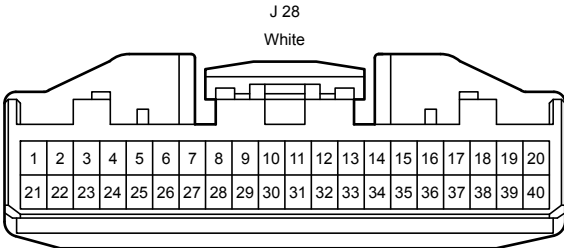
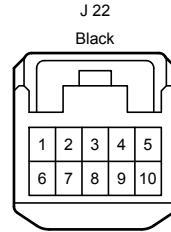
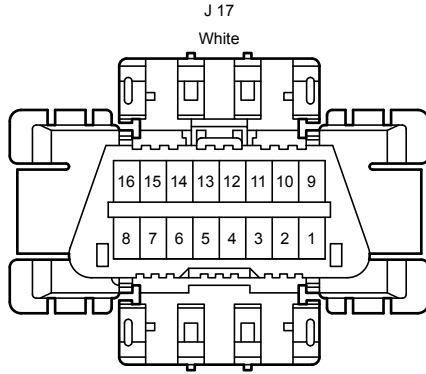
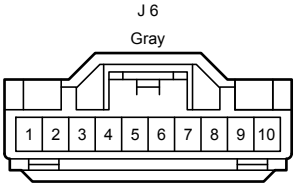
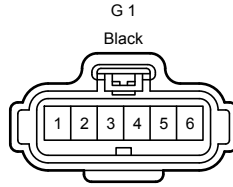
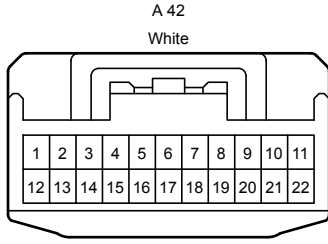
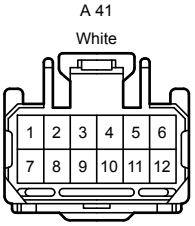

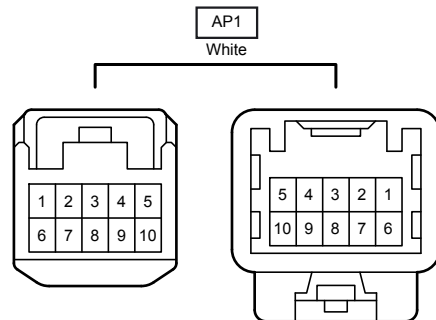
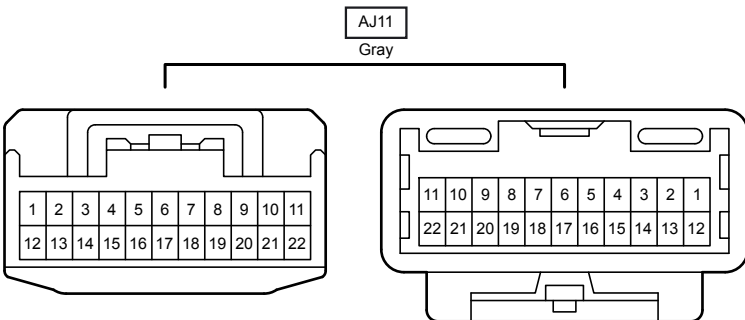
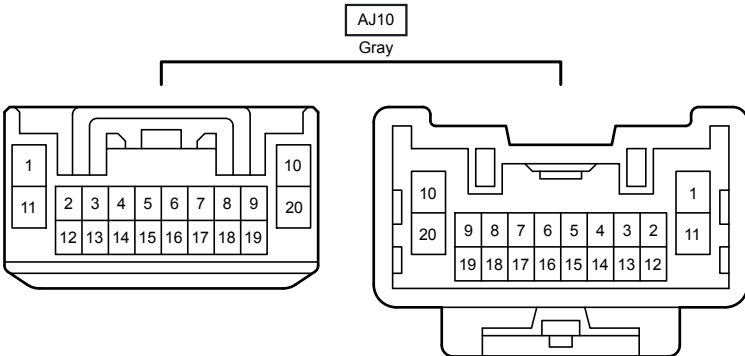
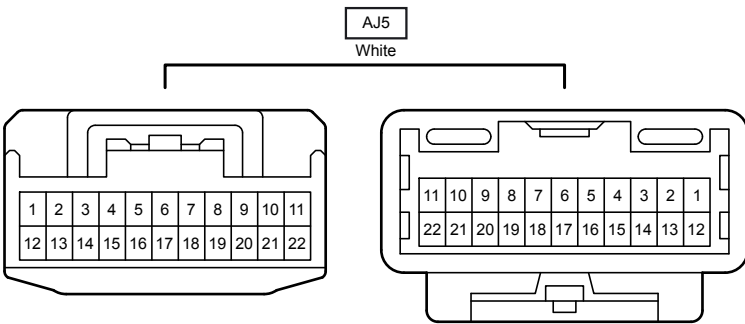
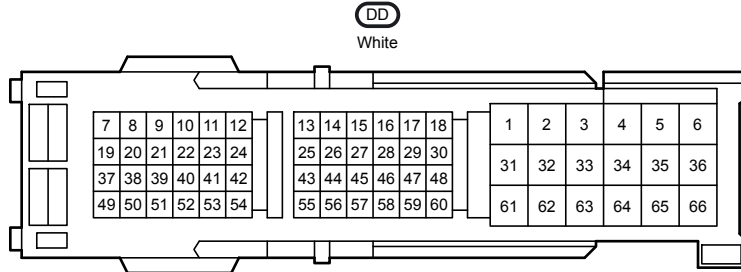
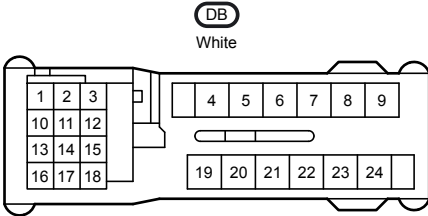
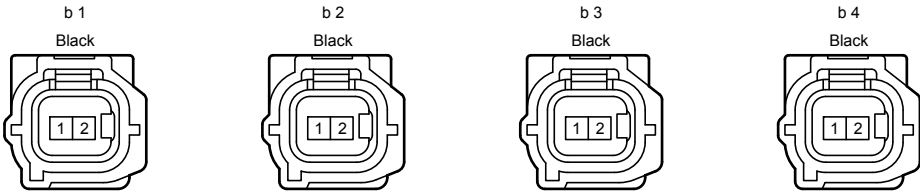

Ab1

Gray

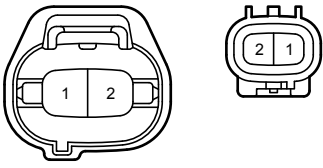

Ab2

Gray

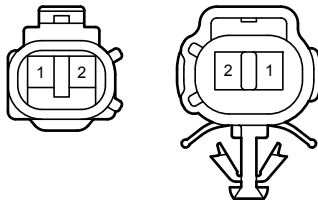

DA1

White

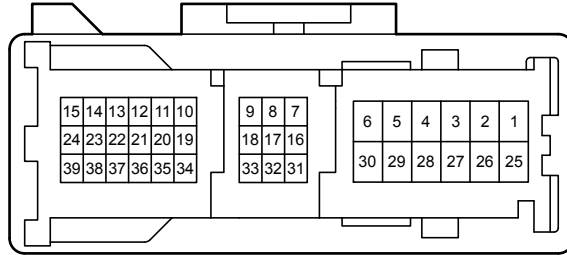
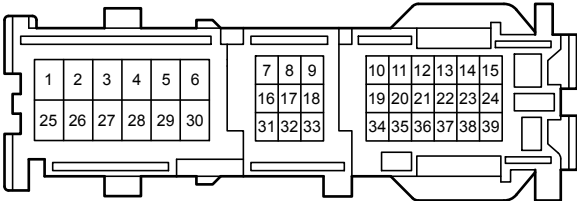

DG1

Black

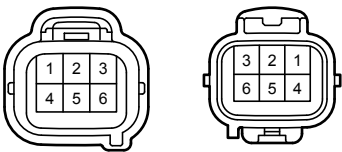

RA1

White

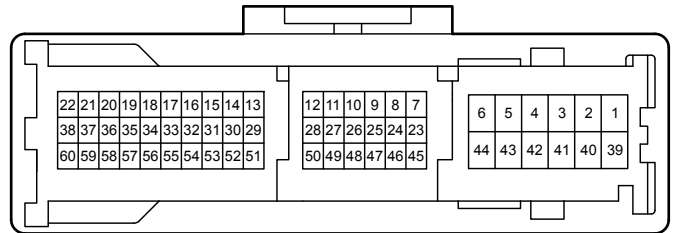
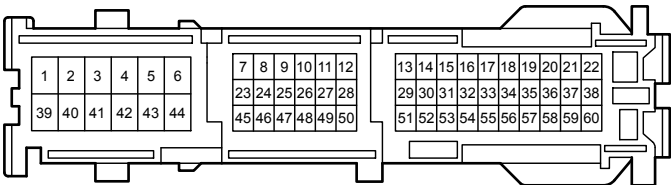

Rb1

White

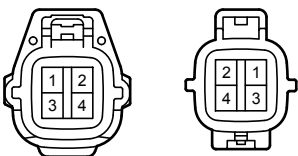

# Air Conditioning

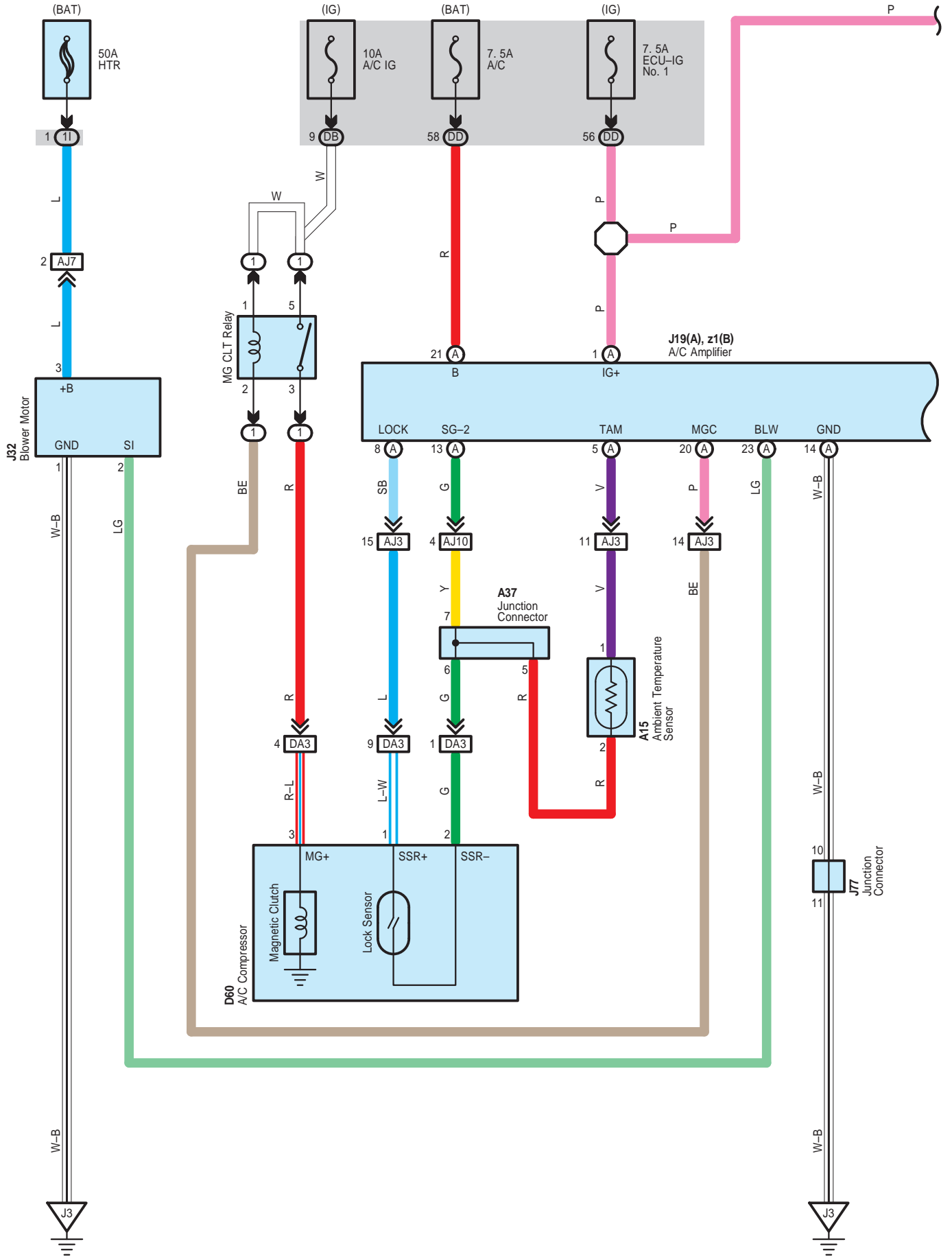





# Air Conditioning

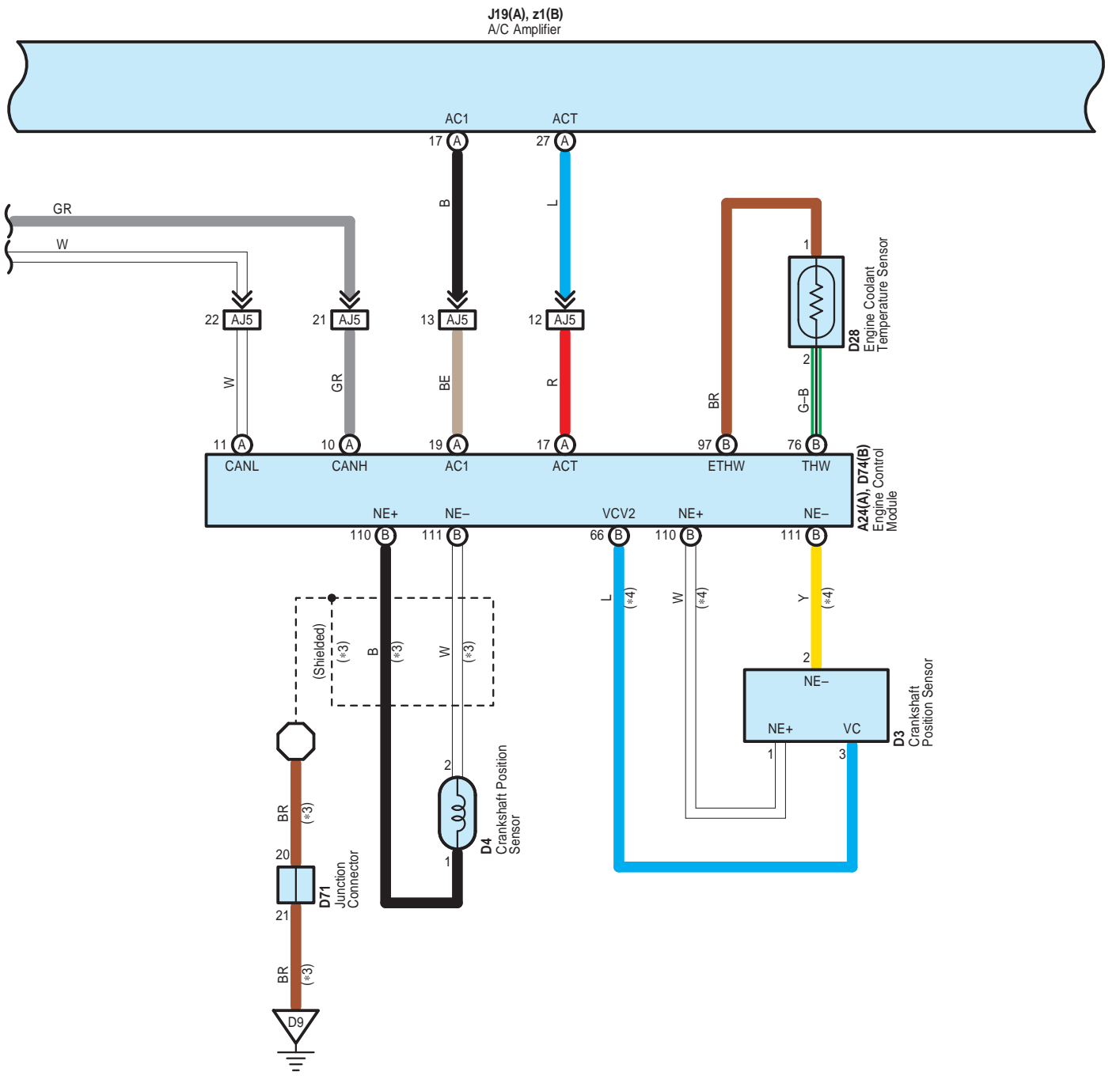



\* 3 : 1GR-FE  
\* 4 : 3UR-FE, 3UR-FBE, 1UR-FE

J19(A), z1(B)  
A/C Amplifier

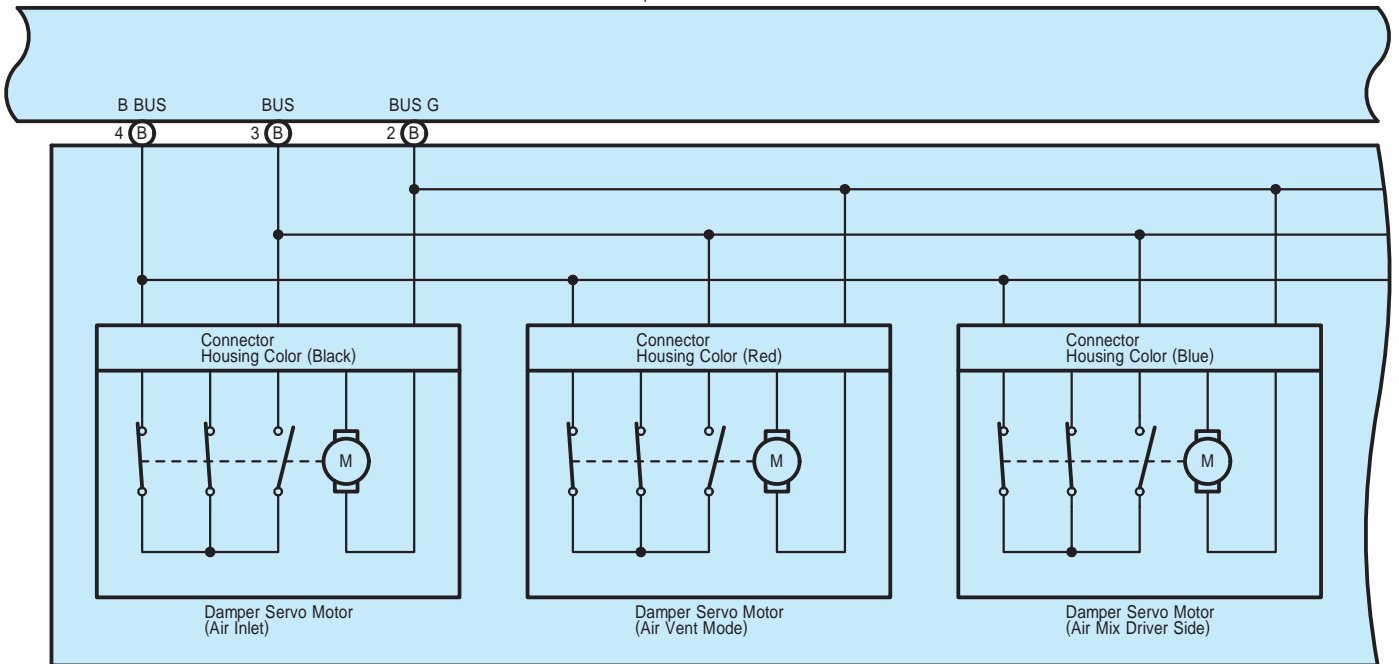

z1(B)  
A/C Blower Assembly



# Air Conditioning

A 15  
Black



A 17  
Black

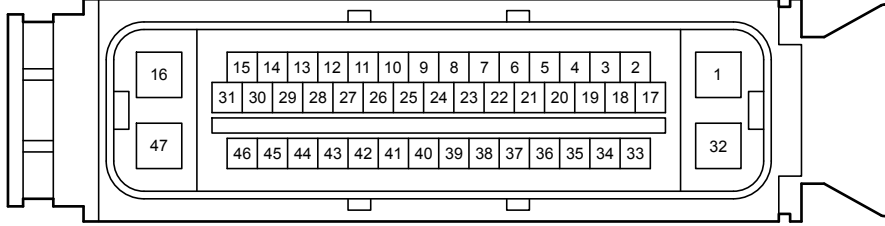

A 20  
Black

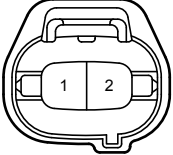

A 24  
Black

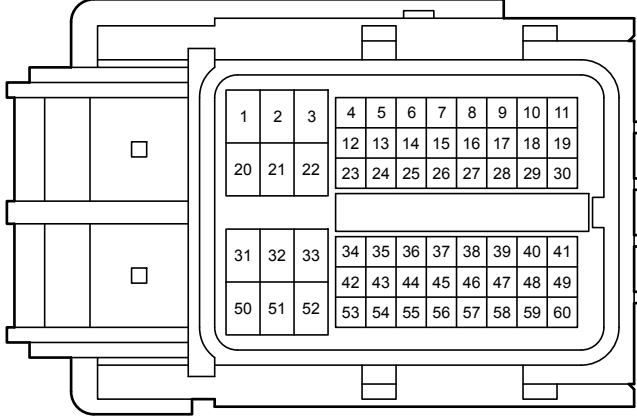

A 37  
White

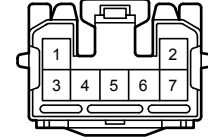

A 44  
White

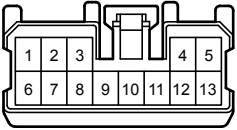

D 3  
Black

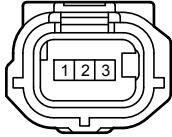

D 4  
Black

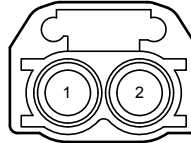

D 28  
Dark Gray



D 60  
Gray

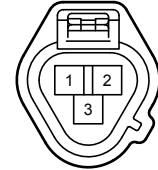

D 71  
White

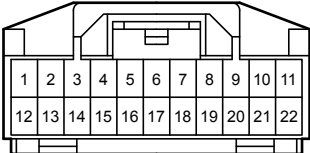

D 74  
Black

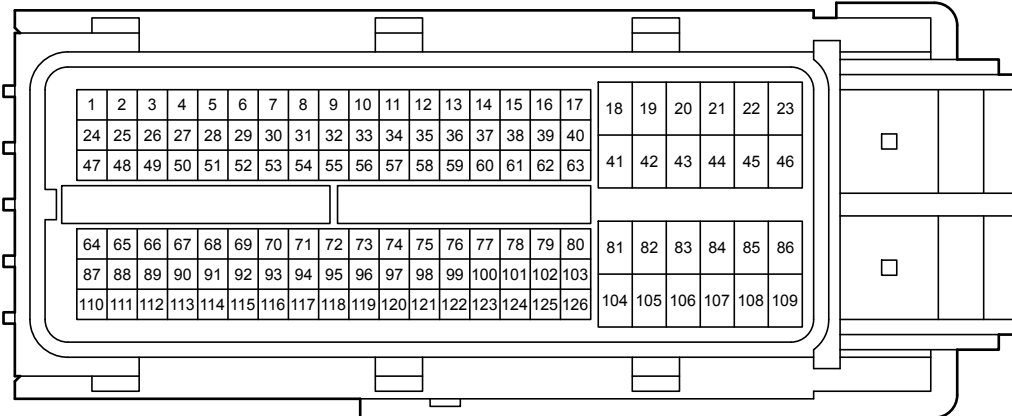

**Air Conditioning**

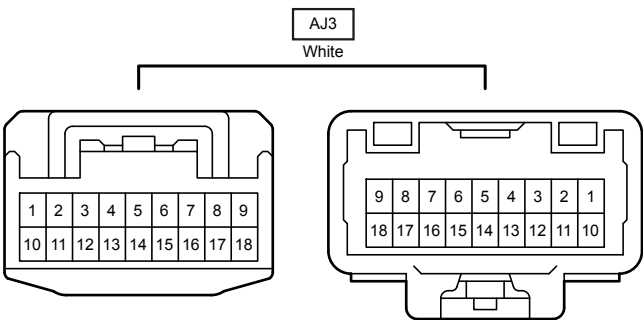
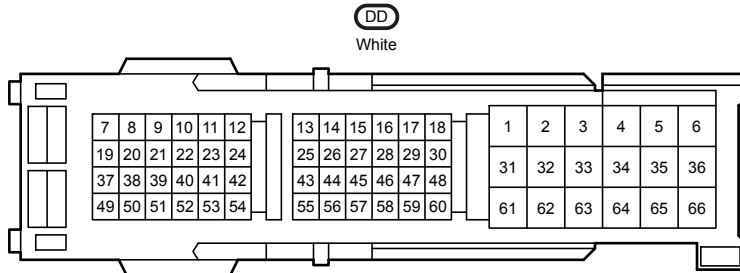
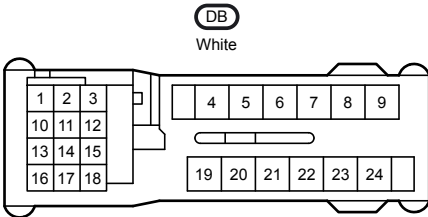
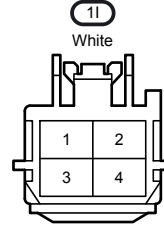
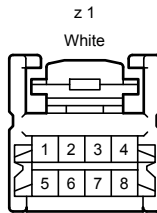
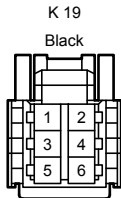
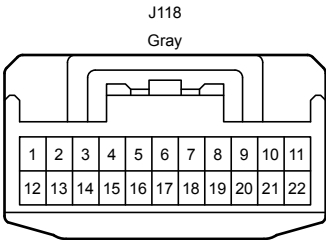
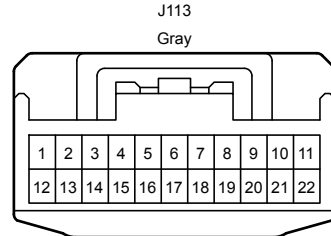
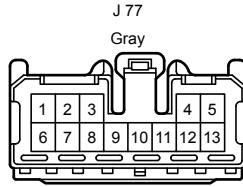
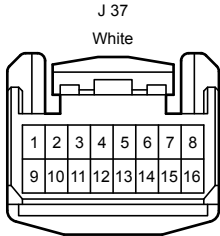
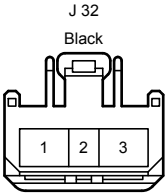
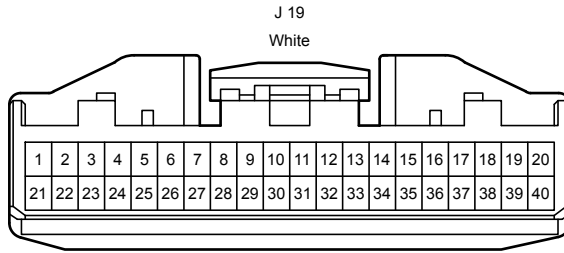
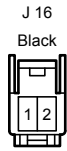
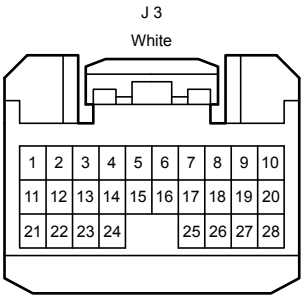

AJ5  
White

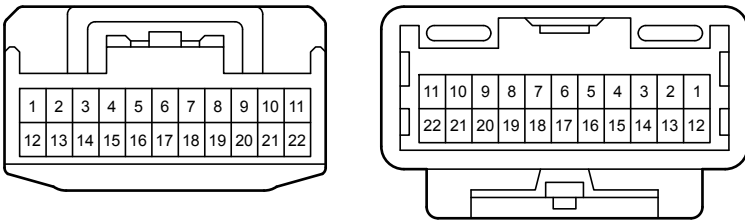

AJ7  
Gray

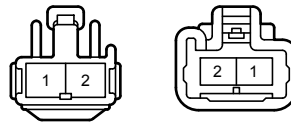

AJ10  
Gray

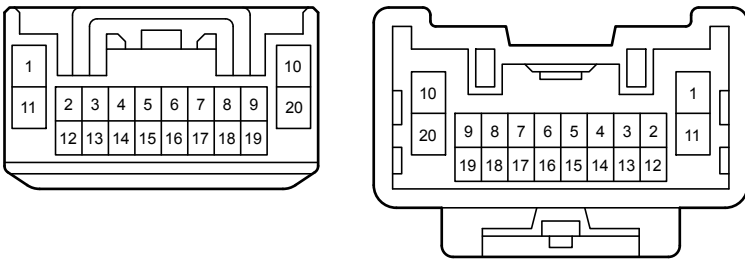

AJ11  
Gray

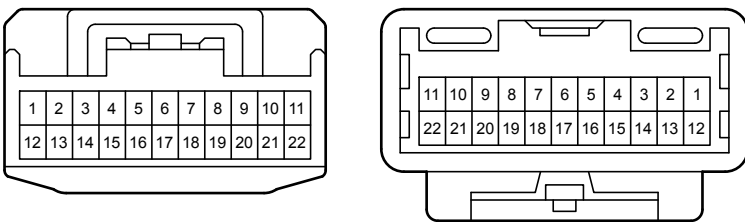

DA3  
White

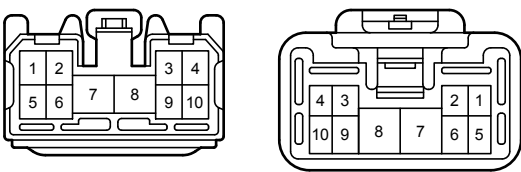

JK1  
White

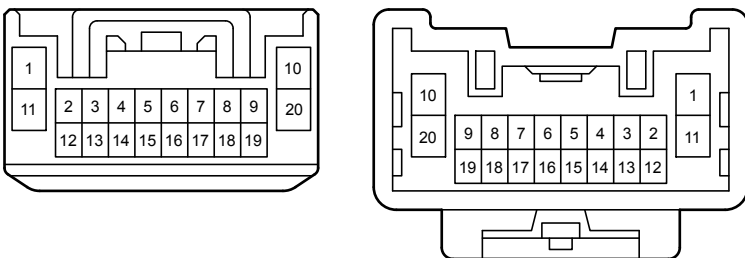

JK2  
White

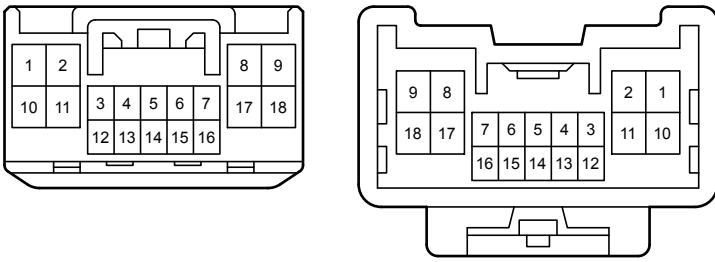

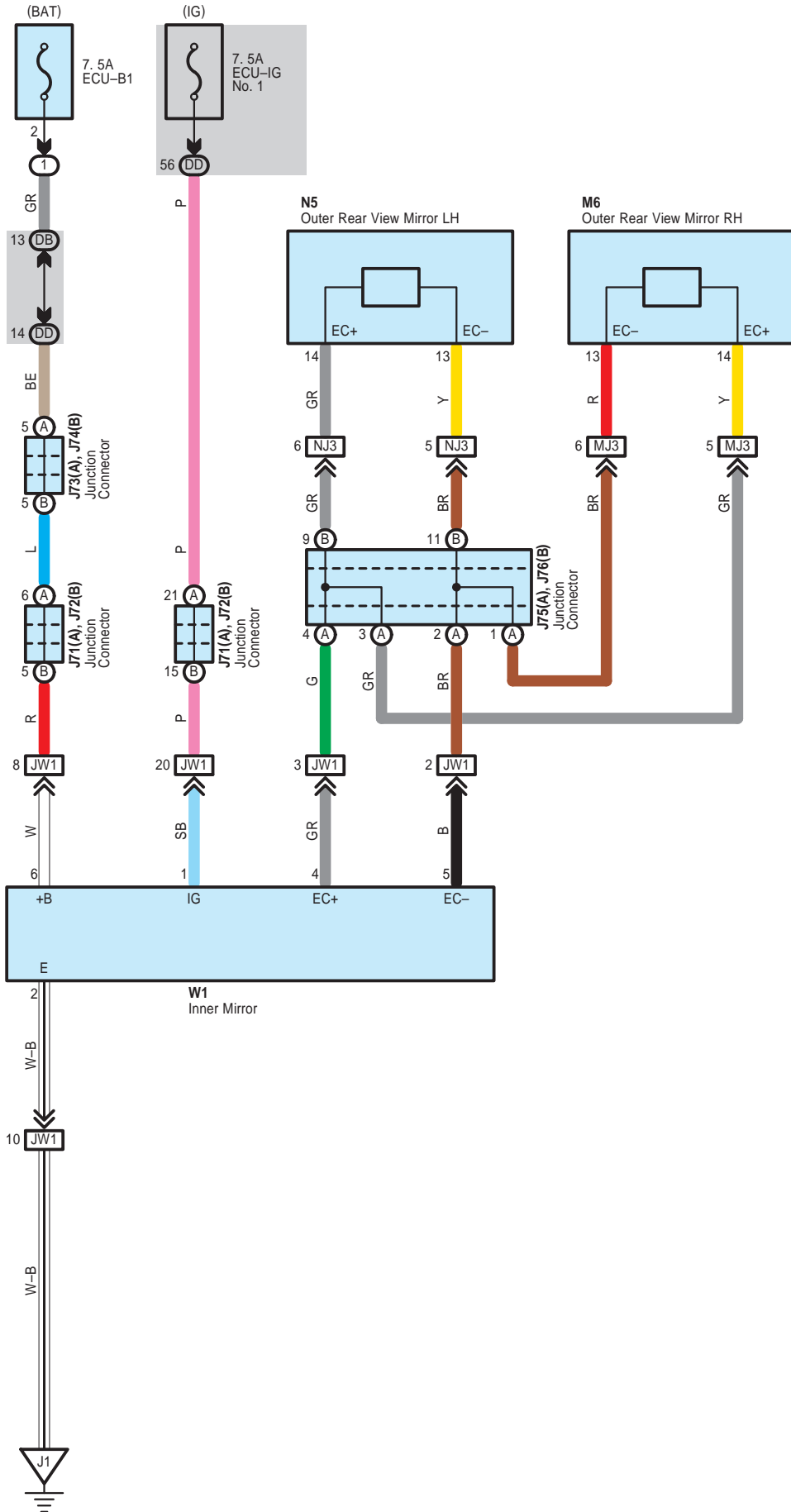



Automatic Glare-Resistant EC Mirror , Compass

J 71  
Black

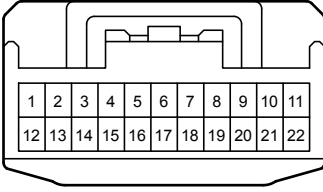

J 72  
Black

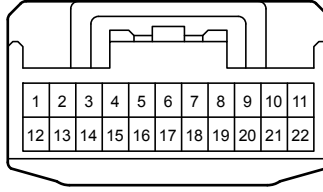

J 73  
Black

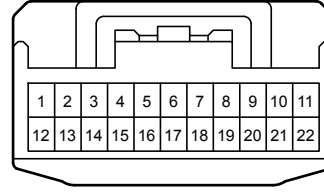

J 74  
Black

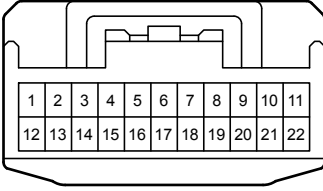

J 75  
White

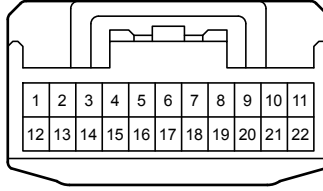

J 76  
White

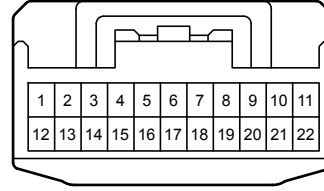

M 6  
White

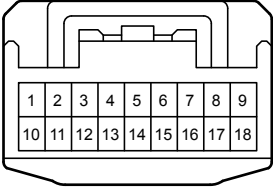

N 5  
White

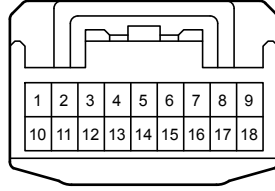

W 1  
Black

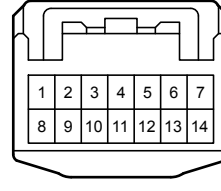

DB  
White

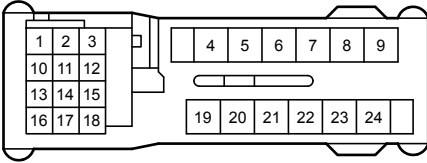

DD  
White

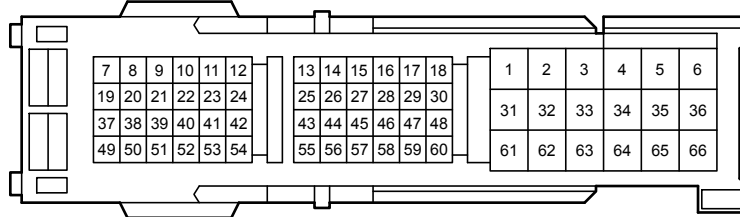

JW1  
White

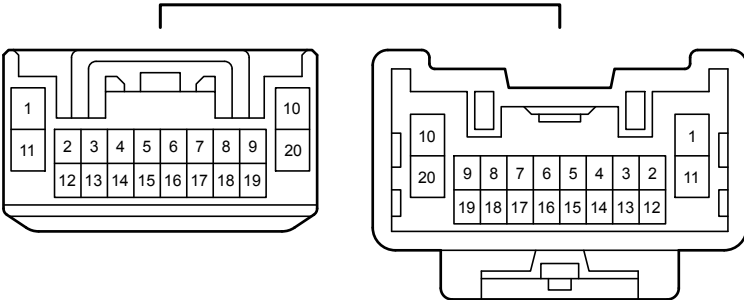

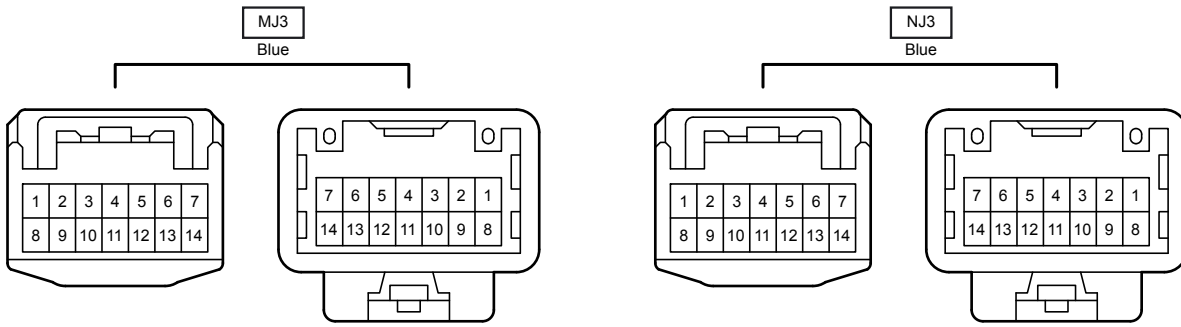

Automatic Light Control , Light Auto Turn Off System

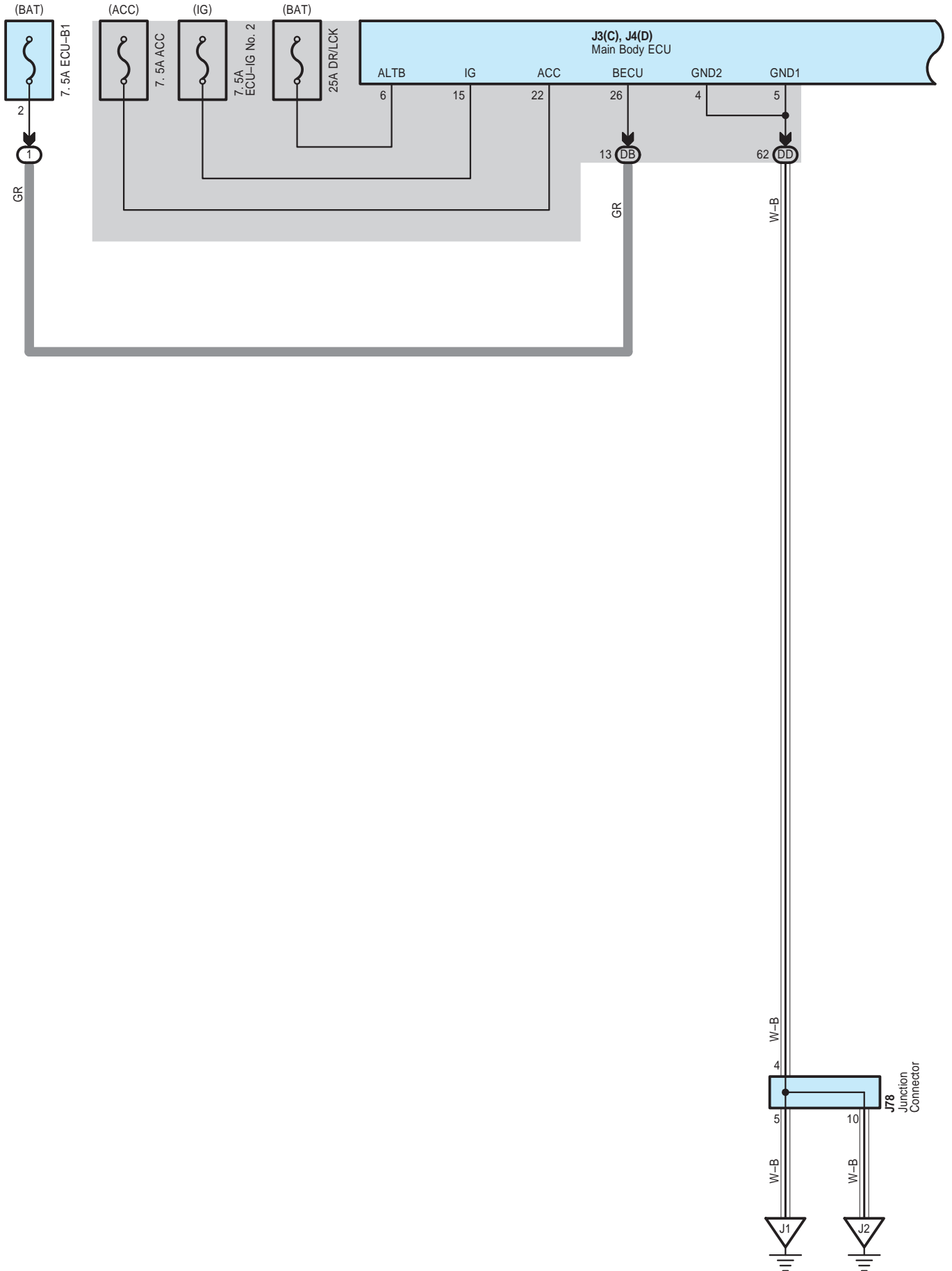

Automatic Light Control , Light Auto Turn Off System

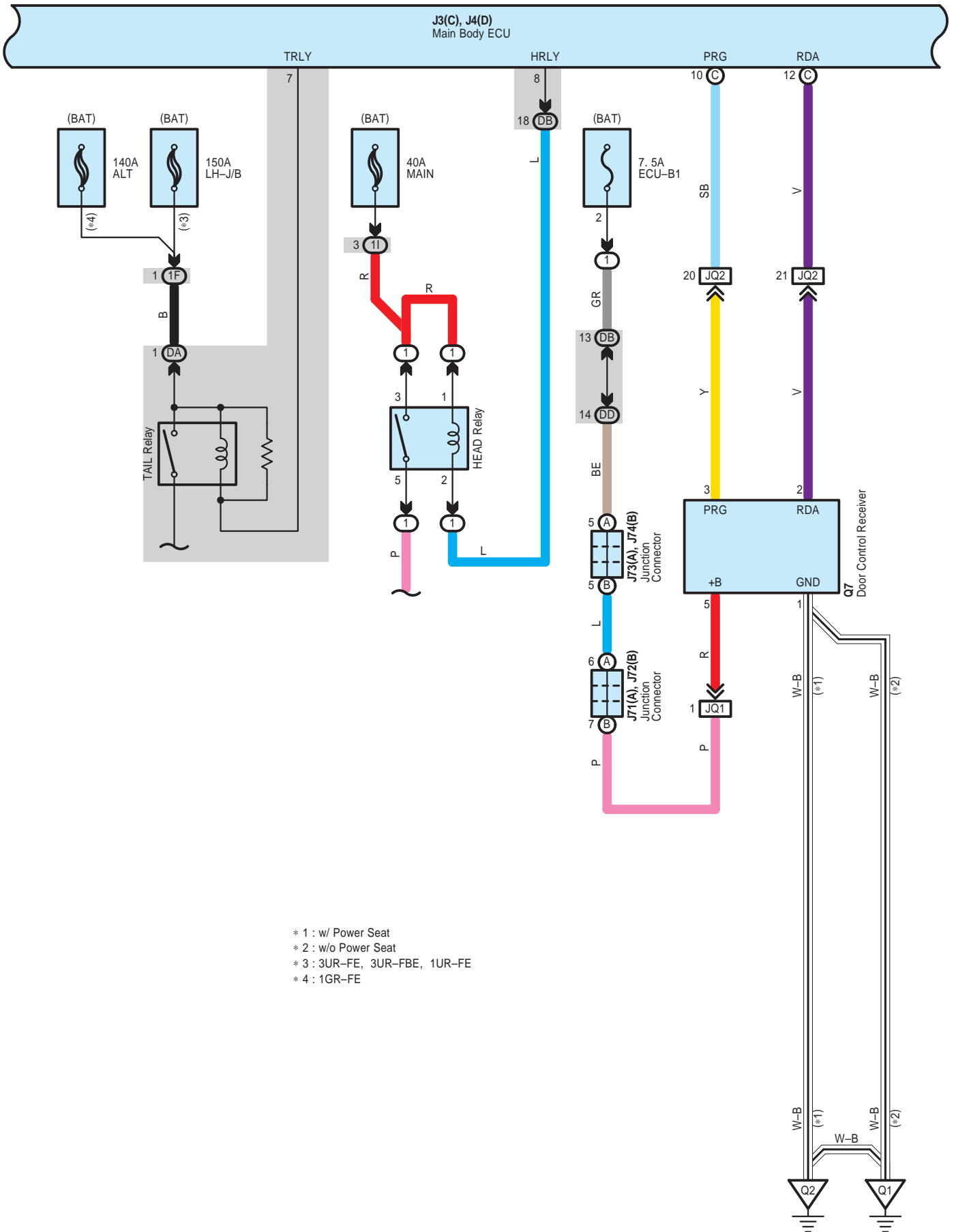

# Automatic Light Control , Light Auto Turn Off System

\* 5 : w/ Seat Position Memory

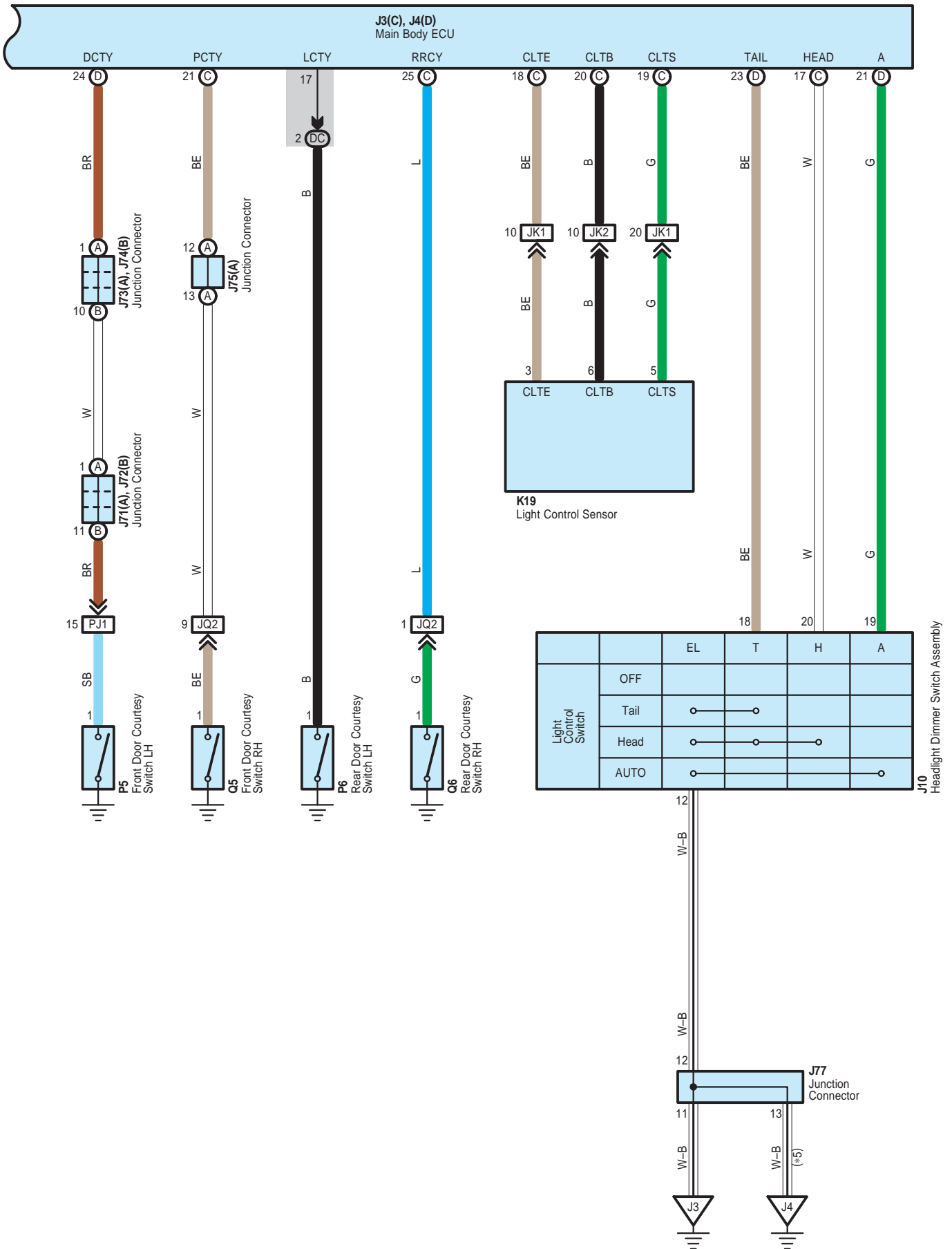

Automatic Light Control , Light Auto Turn Off System

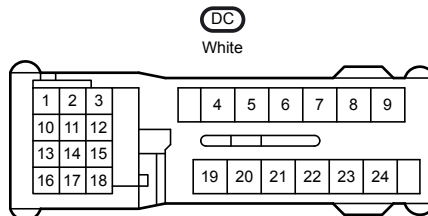
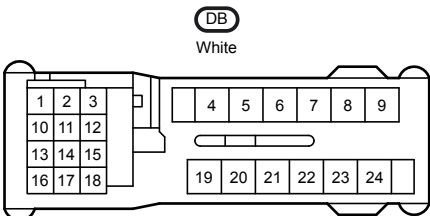
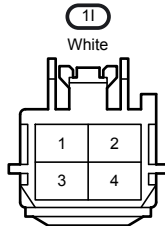
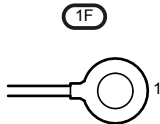
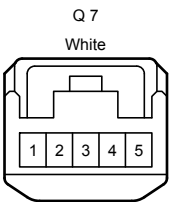
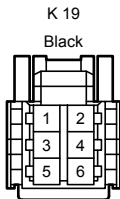
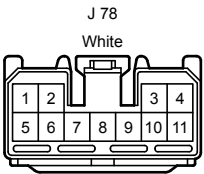
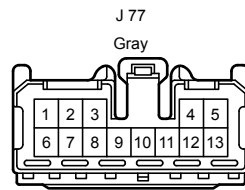
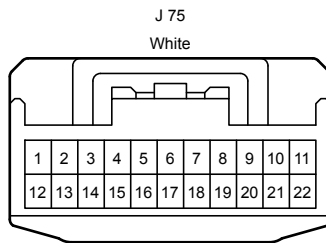
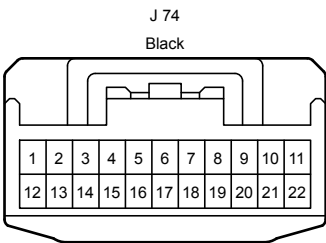
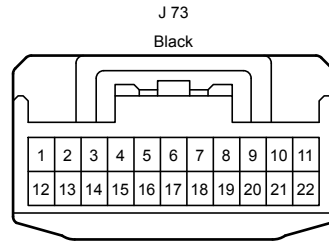
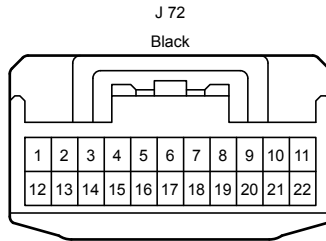
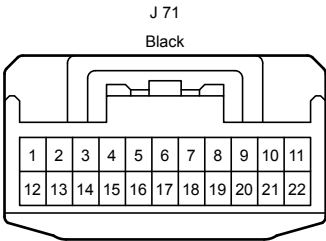
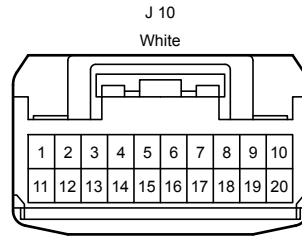
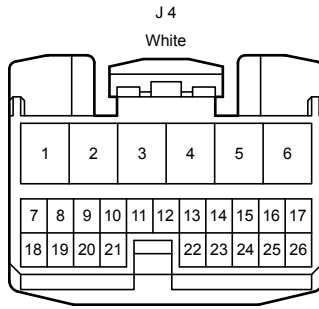
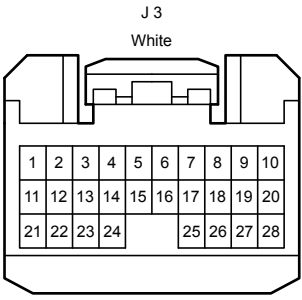

Automatic Light Control , Light Auto Turn Off System

DD

White

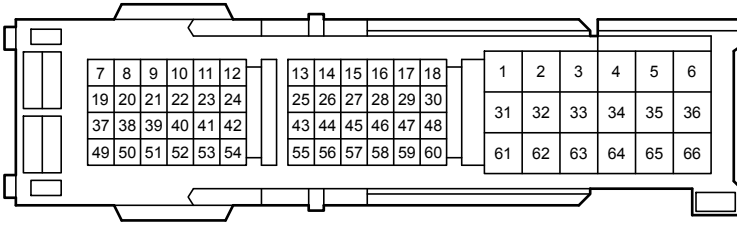

JK1

White

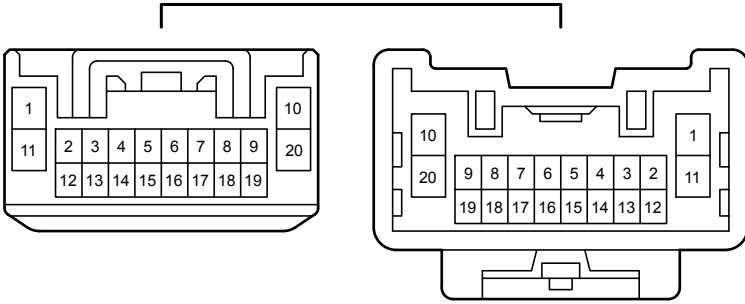

JK2

White

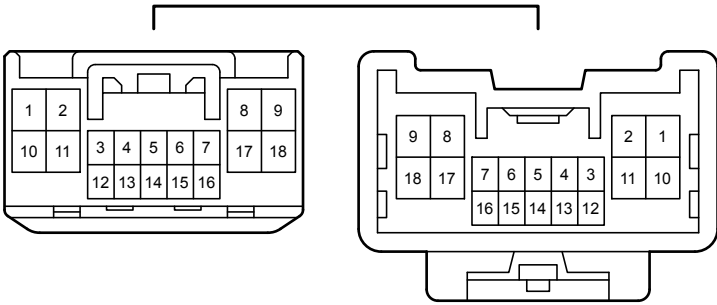

JQ1

Gray

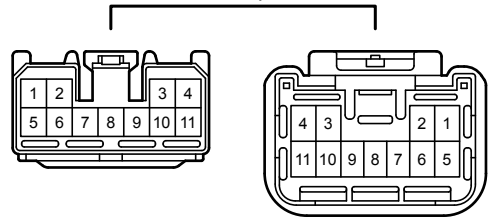

JQ2

Gray

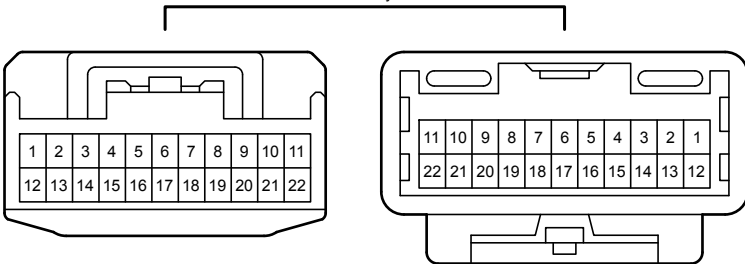

PJ1

Black

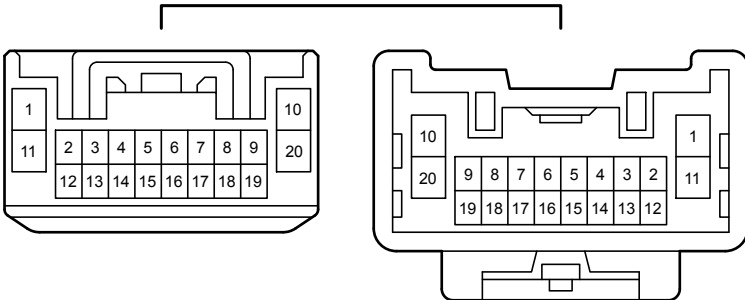

# Accessory Meter

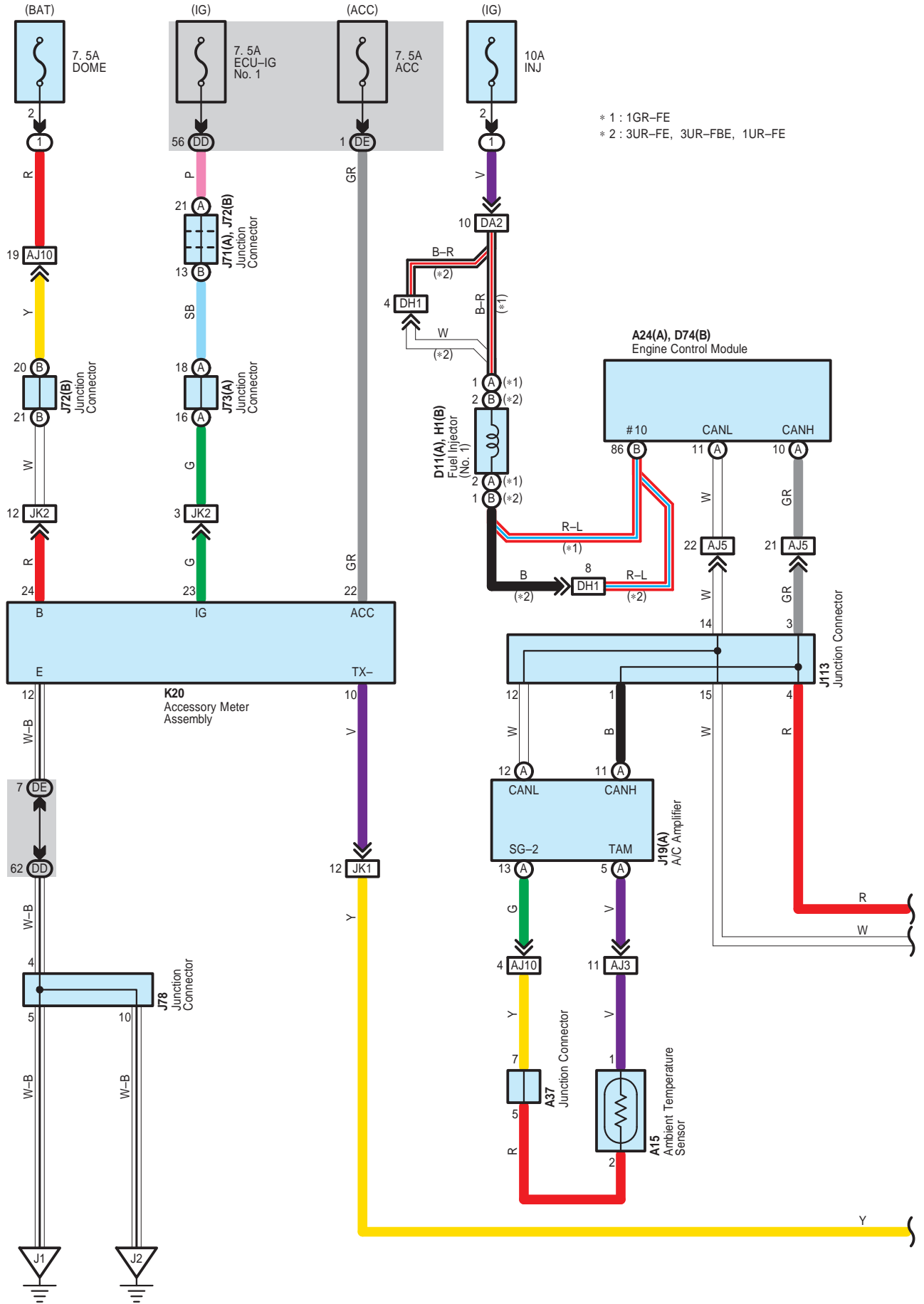



Accessory Meter

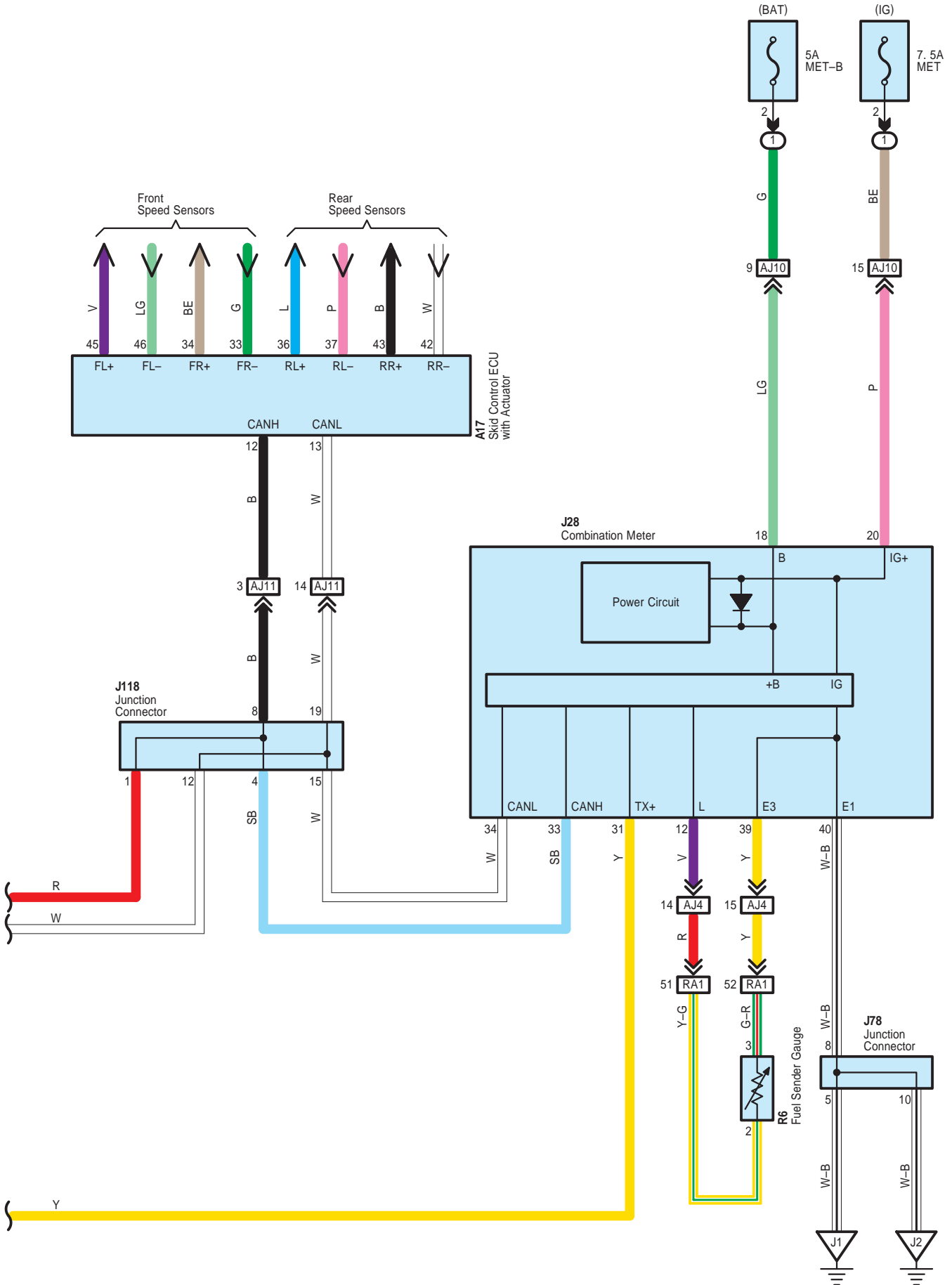

# Accessory Meter

A 15  
Black



A 17  
Black

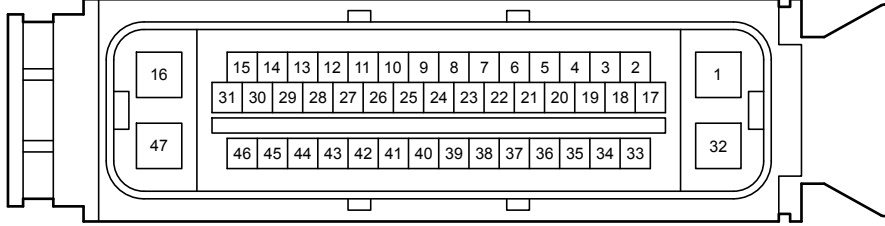

A 24  
Black

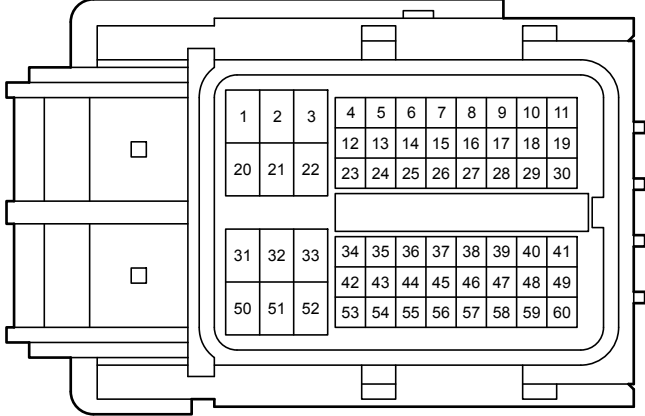

A 37  
White

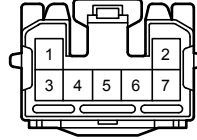

D 11  
Gray

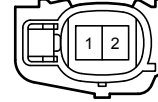

D 74  
Black

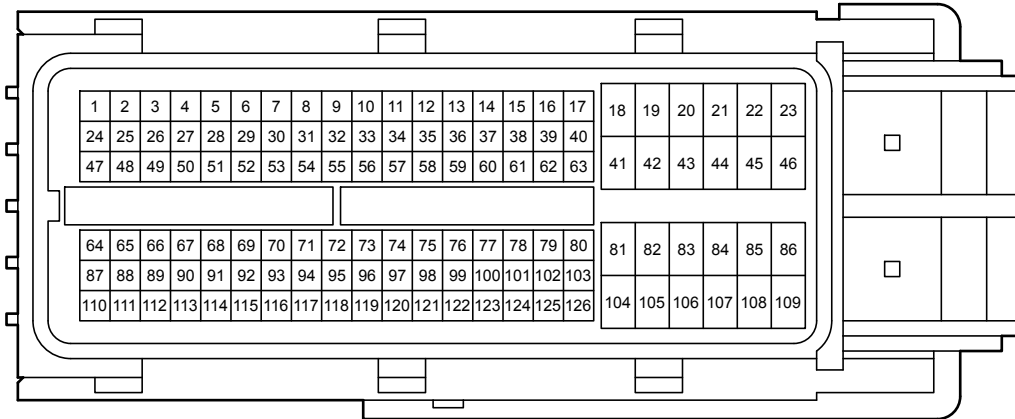

H 1  
Black

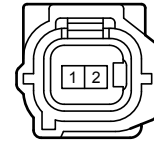

J 19  
White

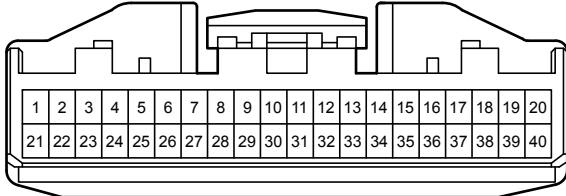

J 28  
White

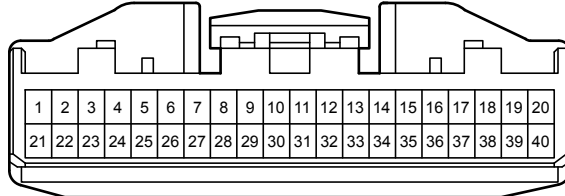

Accessory Meter

J 71  
Black

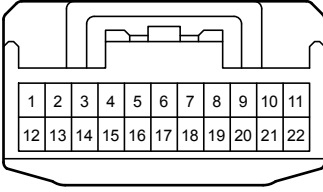

J 72  
Black

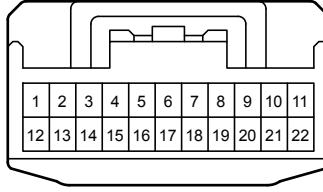

J 73  
Black

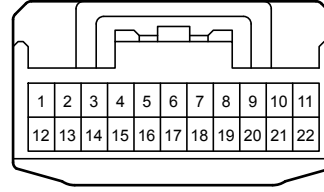

J 78  
White

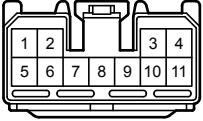

J113  
Gray

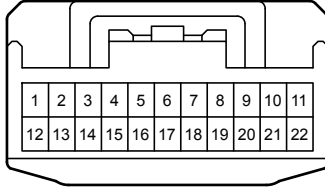

J118  
Gray

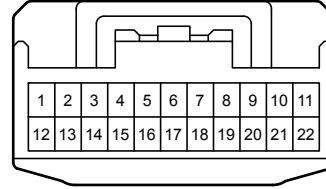

K 20  
White

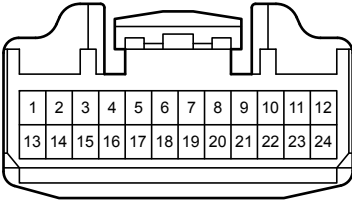

R 6  
White

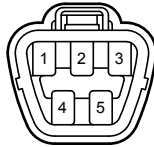

DD  
White

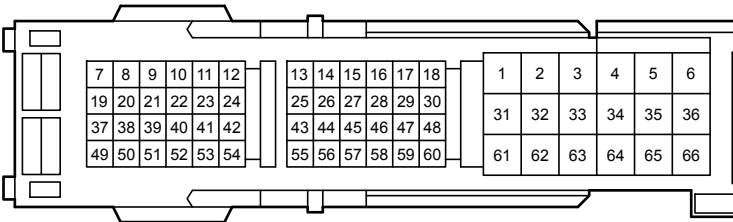

DE  
White

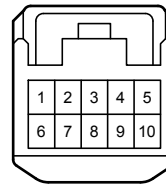

AJ3  
White

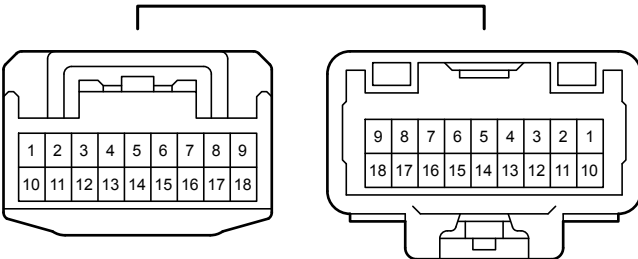

AJ4  
White

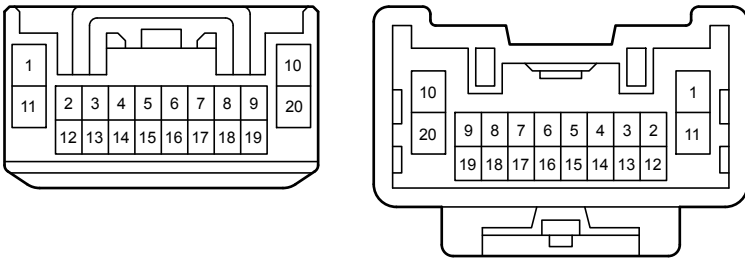

AJ5  
White

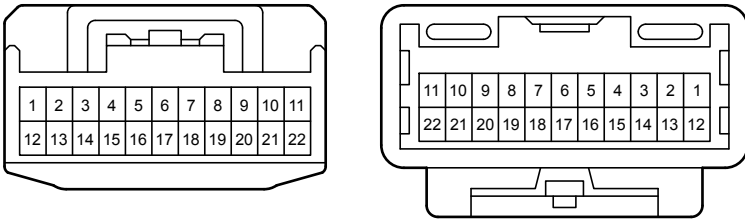

AJ10  
Gray

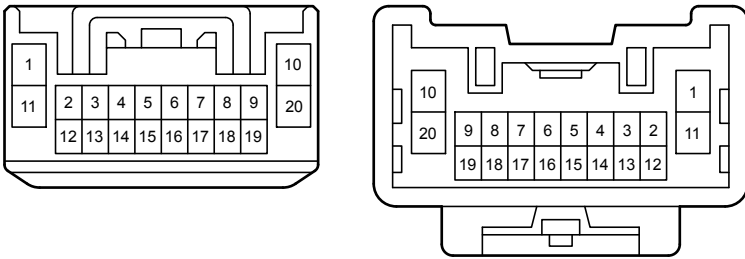

AJ11  
Gray

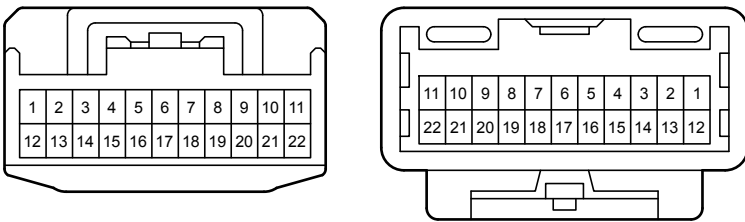

DA2  
White

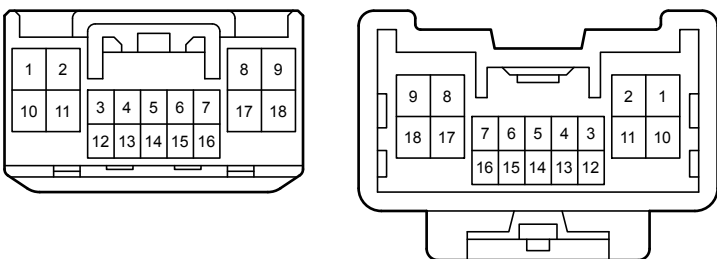

DH1  
Gray

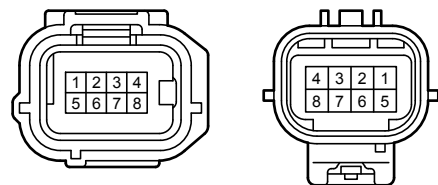



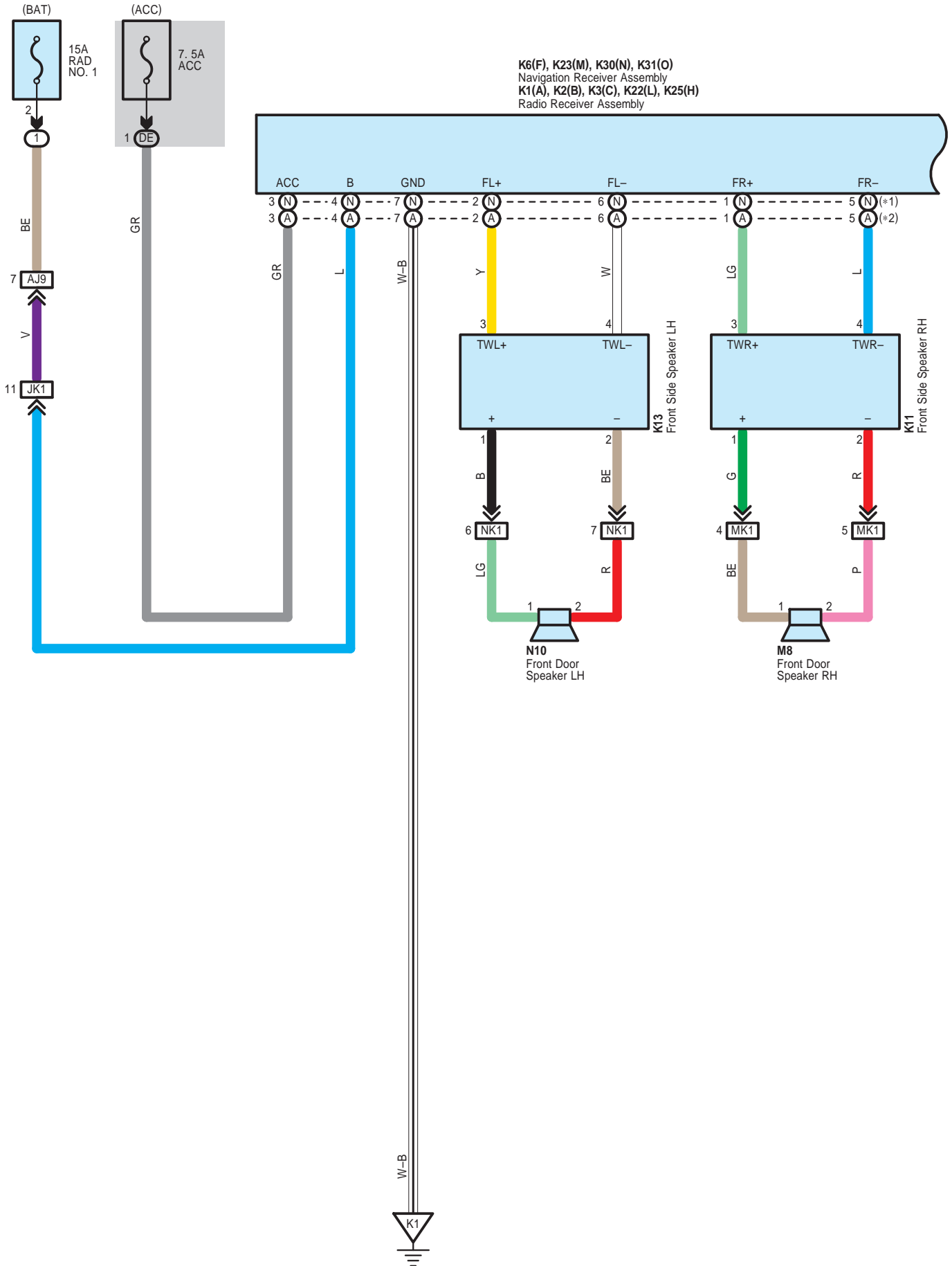

K6(F), K23(M), K30(N), K31(O)  
 Navigation Receiver Assembly  
 K1(A), K2(B), K3(C), K22(L), K25(H)  
 Radio Receiver Assembly

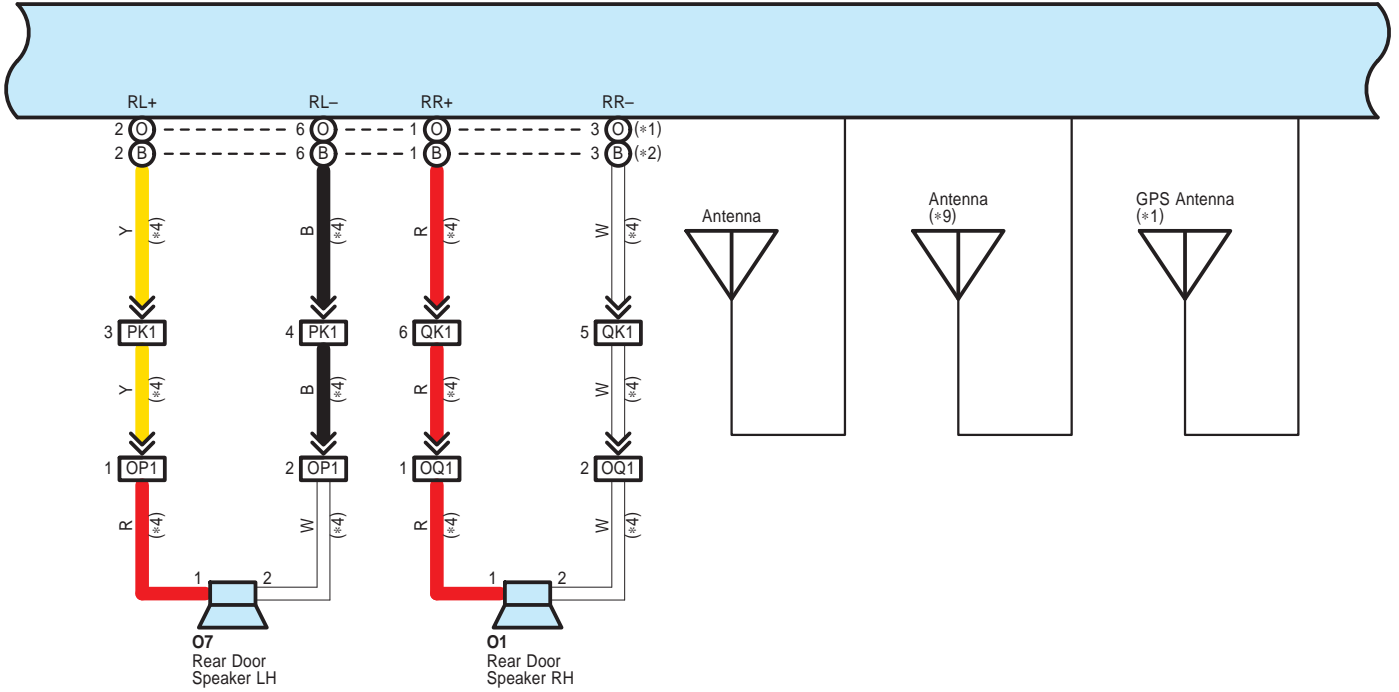

- \* 1 : w/ Navigation System
- \* 2 : w/o Navigation System
- \* 4 : w/ Rear Door Speaker
- \* 9 : w/ SDARS Antenna

K6(F), K23(M), K30(N), K31(O)  
 Navigation Receiver Assembly  
 K1(A), K2(B), K3(C), K22(L), K25(H)  
 Radio Receiver Assembly

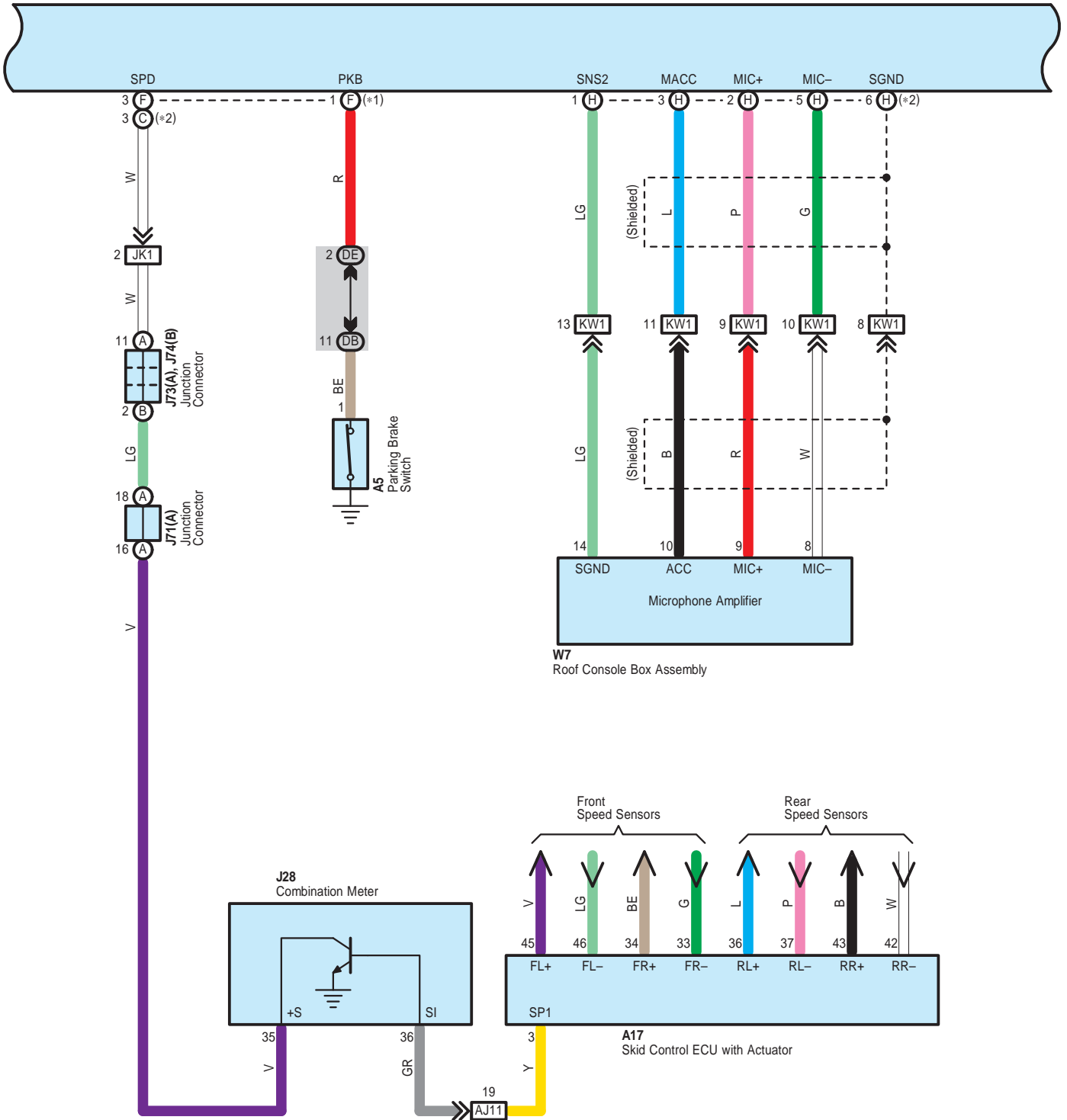



K6(F), K23(M), K30(N), K31(O)  
 Navigation Receiver Assembly  
 K1(A), K2(B), K3(C), K22(L), K25(H)  
 Radio Receiver Assembly

- \* 1 : w/ Navigation System
- \* 2 : w/o Navigation System
- \* 3 : w/ Rear View Monitor

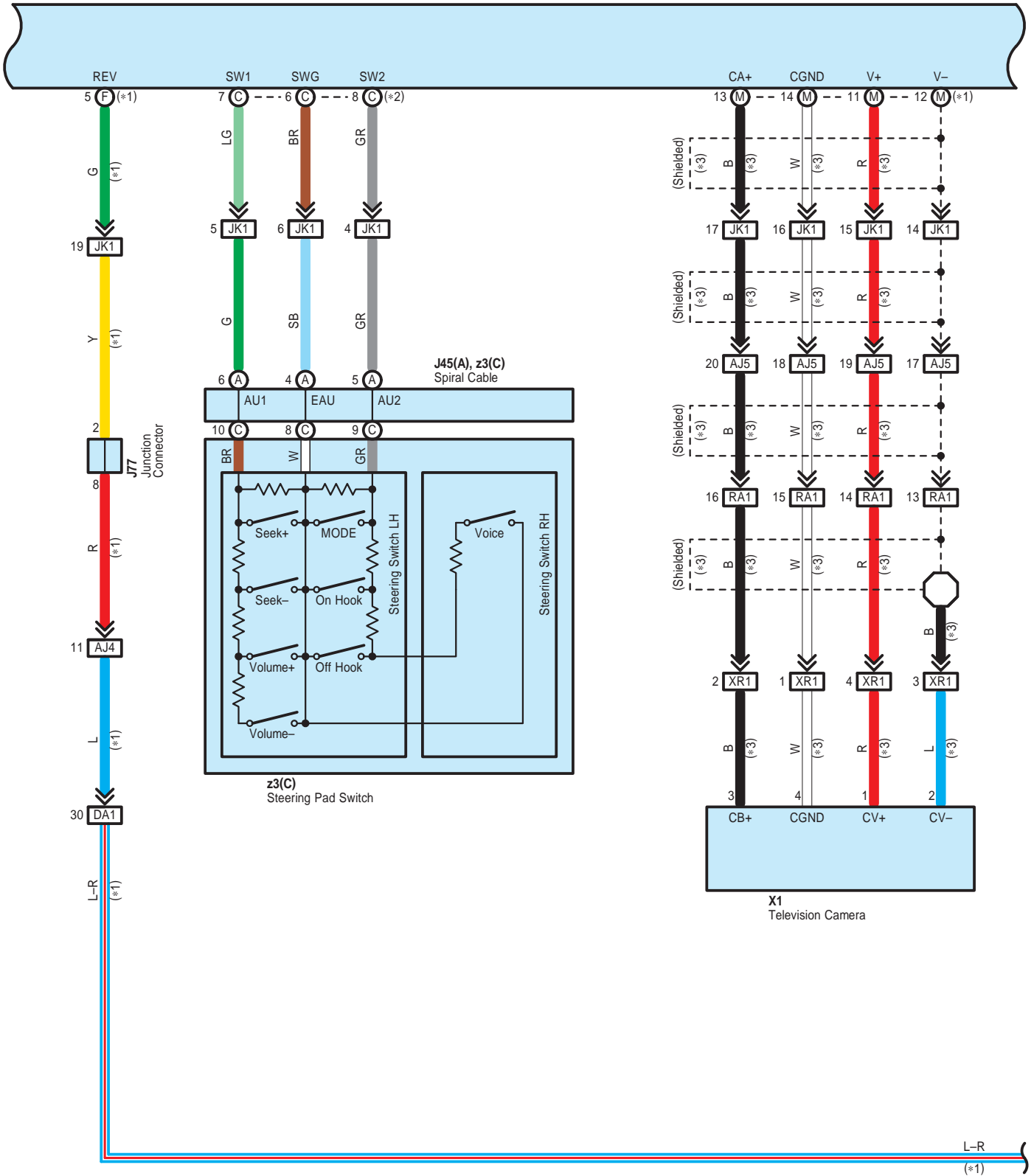

K6(F), K23(M), K30(N), K31(O)  
 Navigation Receiver Assembly  
 K1(A), K2(B), K3(C), K22(L), K25(H)  
 Radio Receiver Assembly

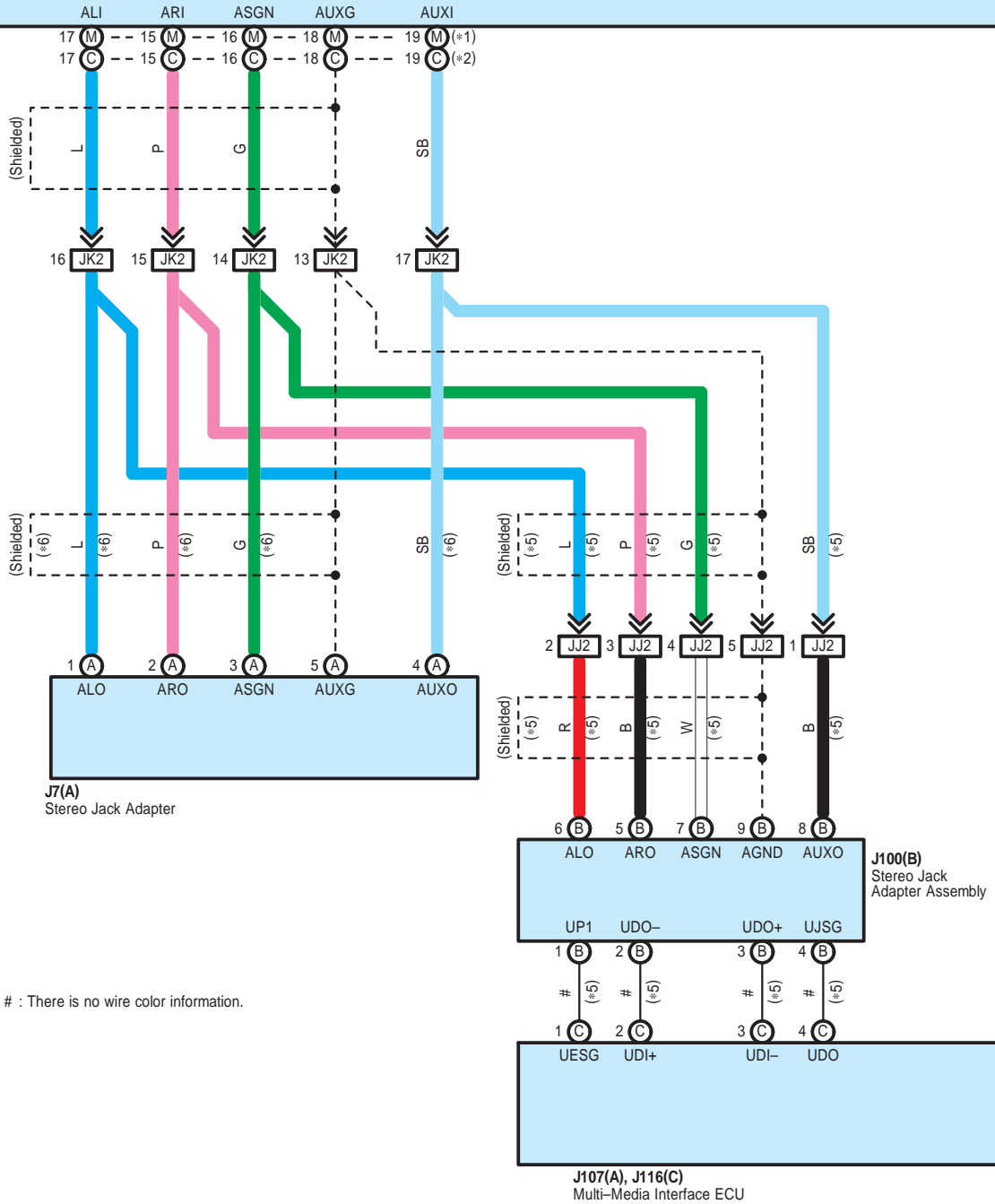

# : There is no wire color information.



K6(F), K23(M), K30(N), K31(O)  
 Navigation Receiver Assembly  
 K1(A), K2(B), K3(C), K22(L), K25(H)  
 Radio Receiver Assembly

- \* 1 : w/ Navigation System
- \* 2 : w/o Navigation System
- \* 5 : w/ Multi-Media Interface ECU
- \* 6 : w/o Multi-Media Interface ECU

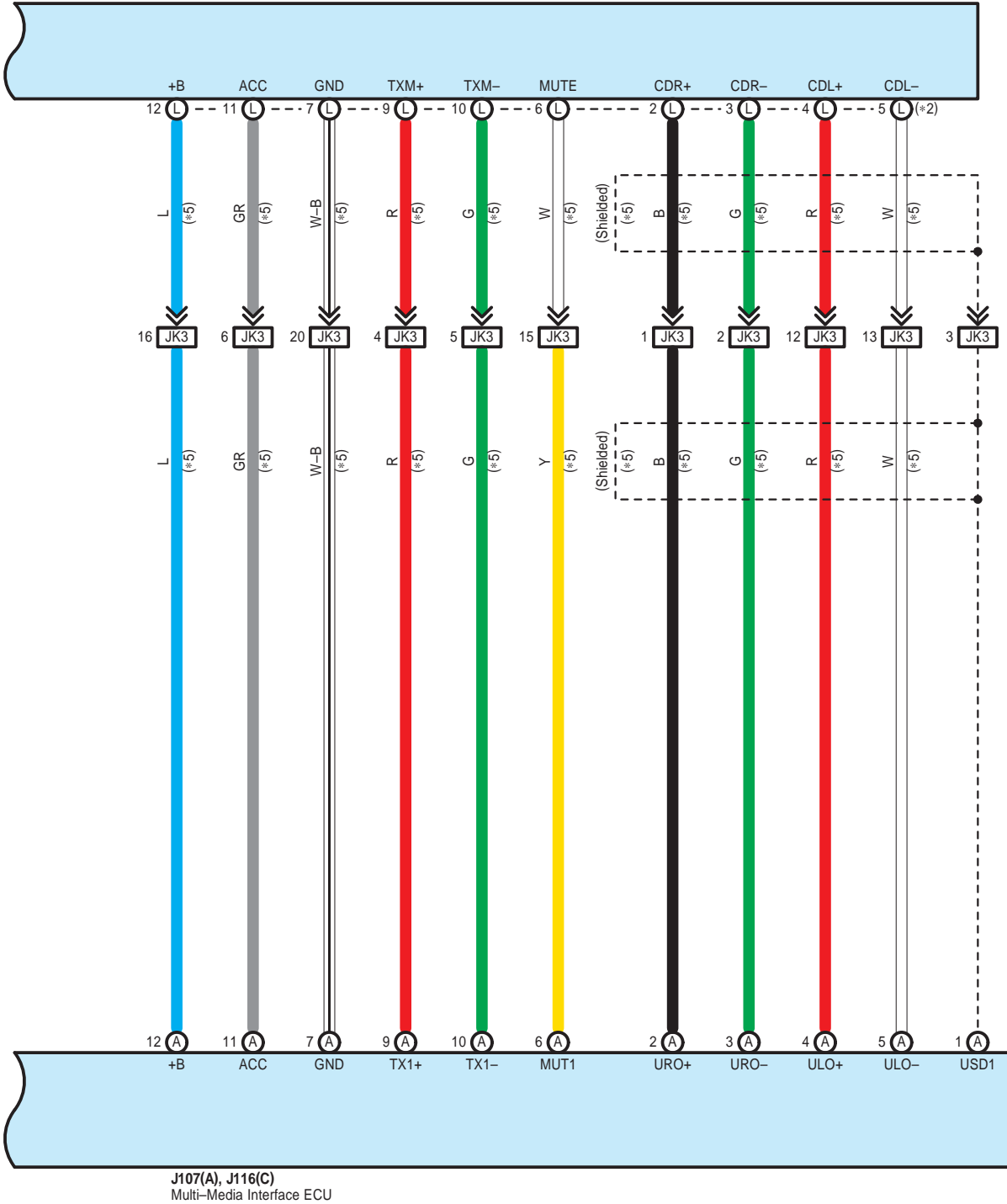

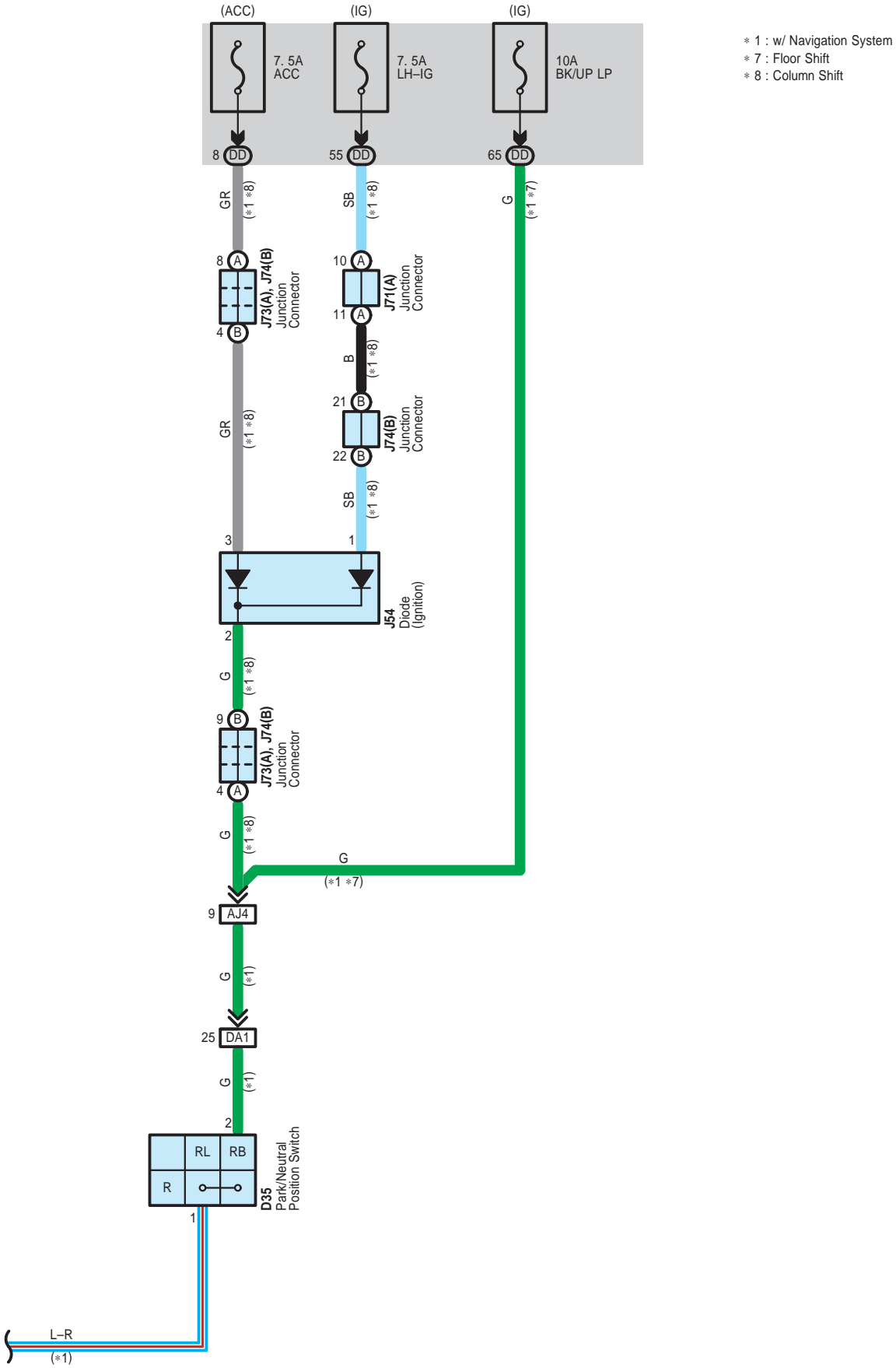

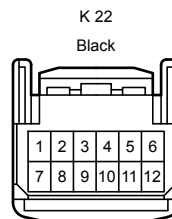
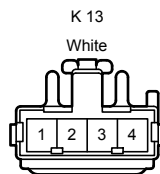
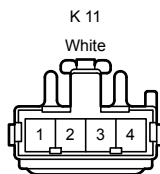
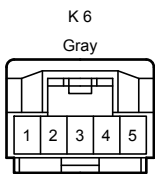
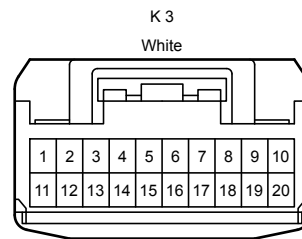
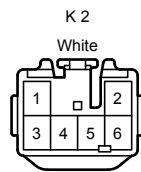
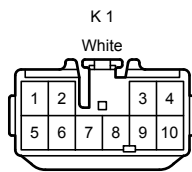
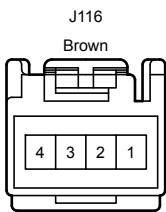
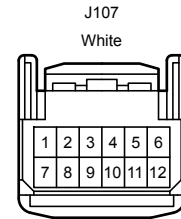
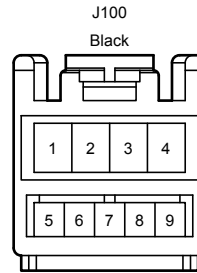
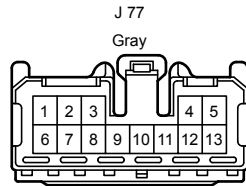
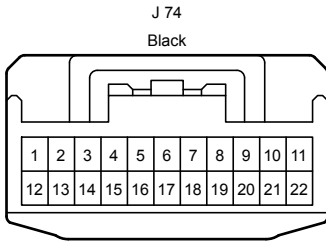
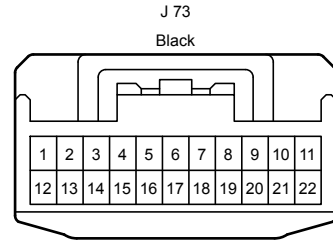
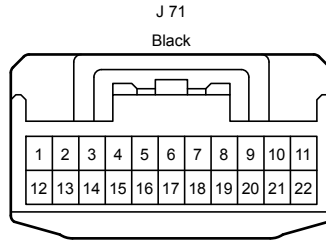
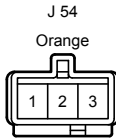
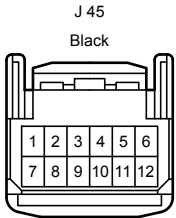
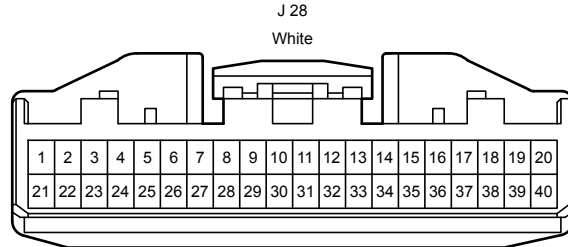
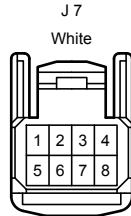
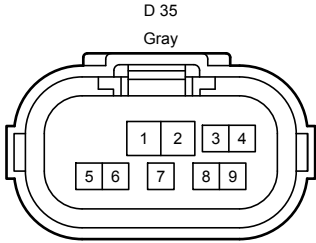
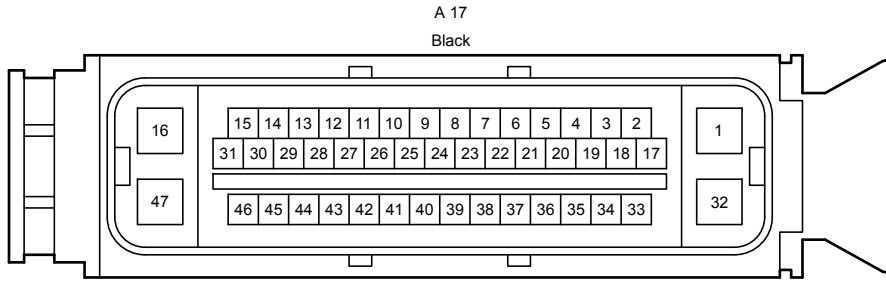

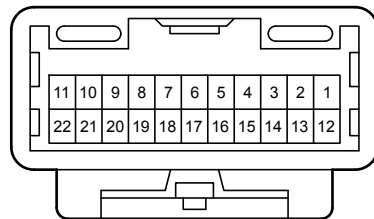
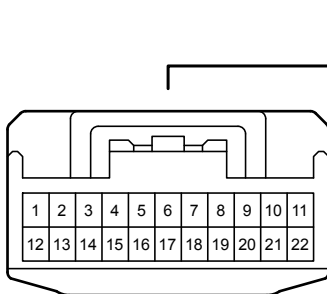
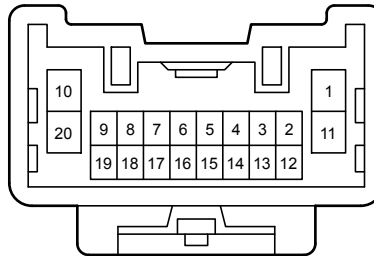
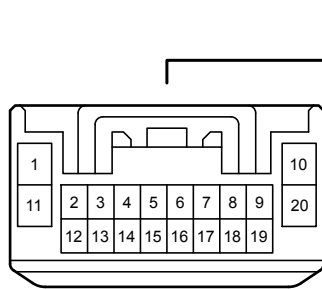
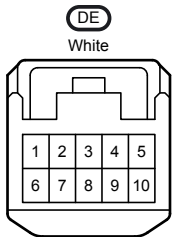
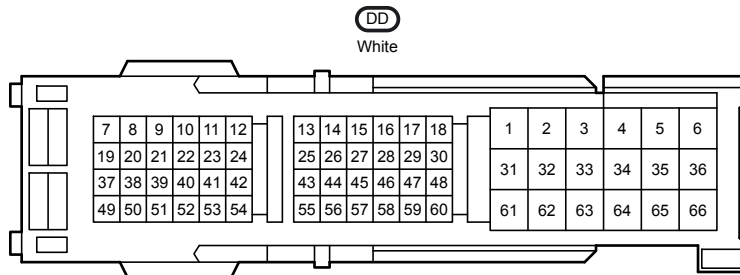
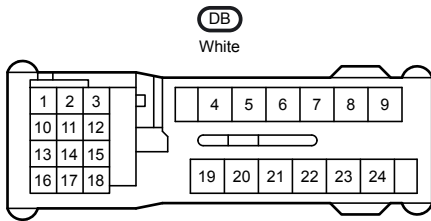
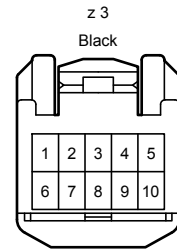
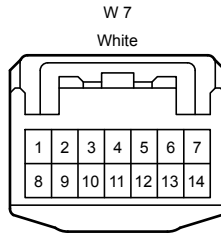
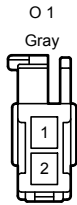
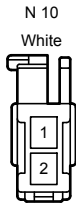
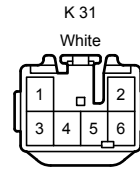
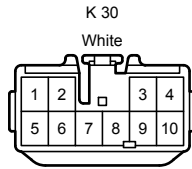
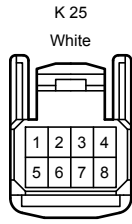
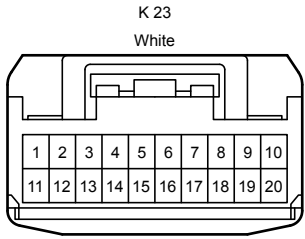

AJ9  
Gray

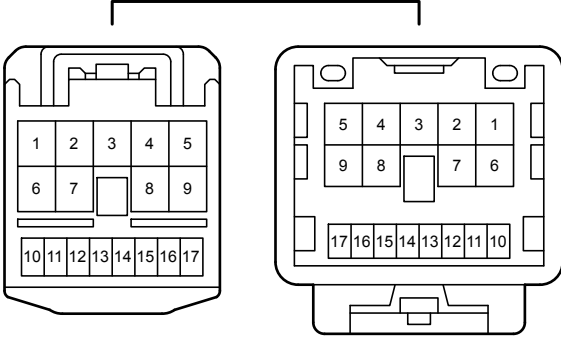

AJ11  
Gray

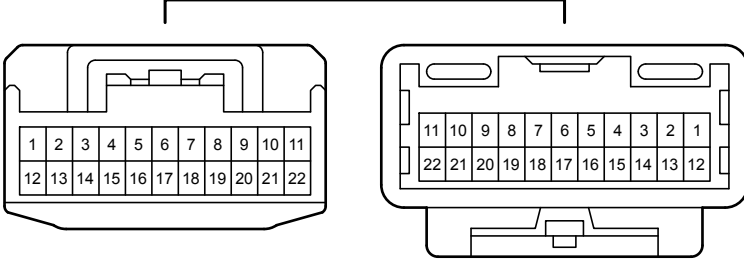

DA1  
White

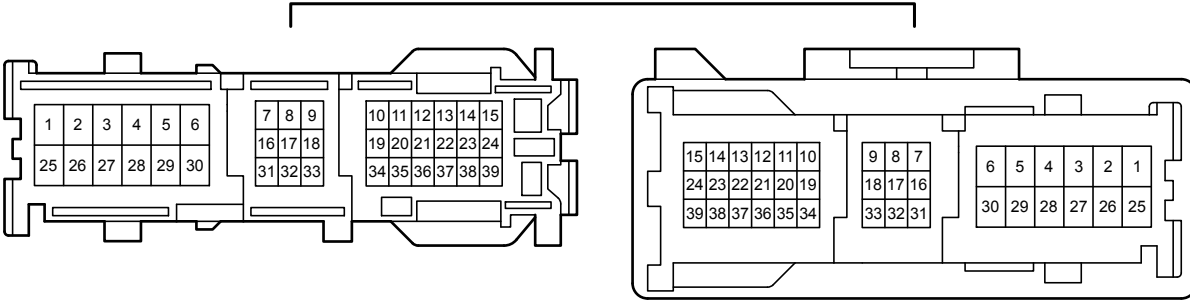

JJ2  
White

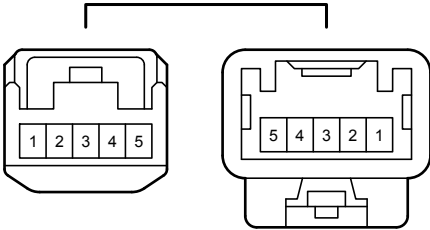

JK1  
White

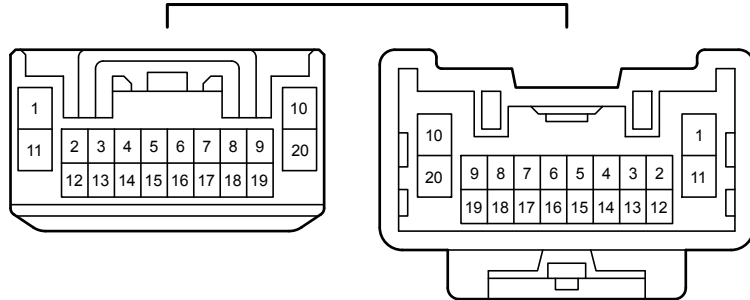

JK2  
White

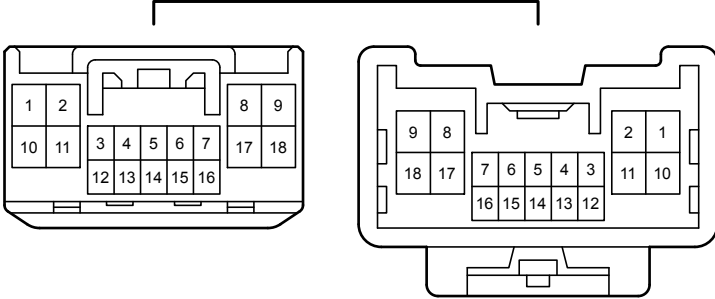

JK3  
White

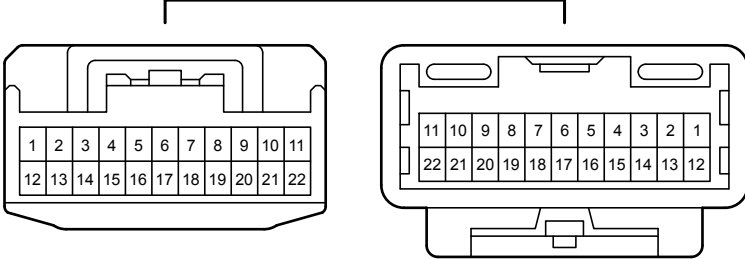

KW1  
White

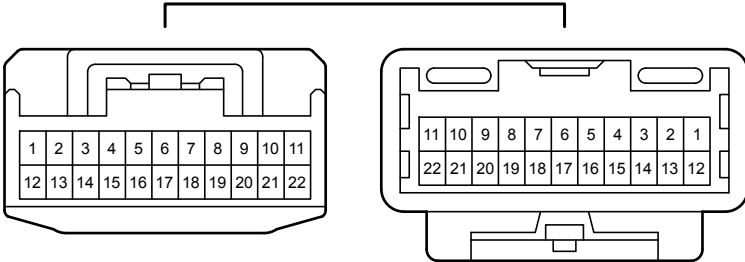

MK1  
Blue

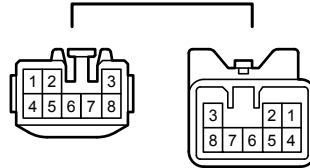

NK1  
Blue

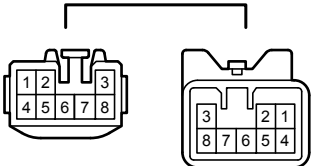

OP1  
White

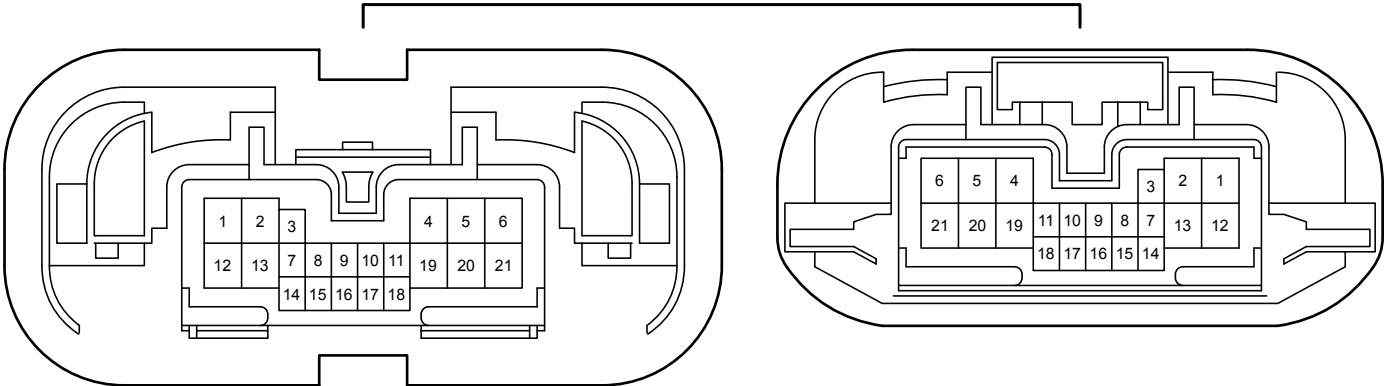



OQ1  
White

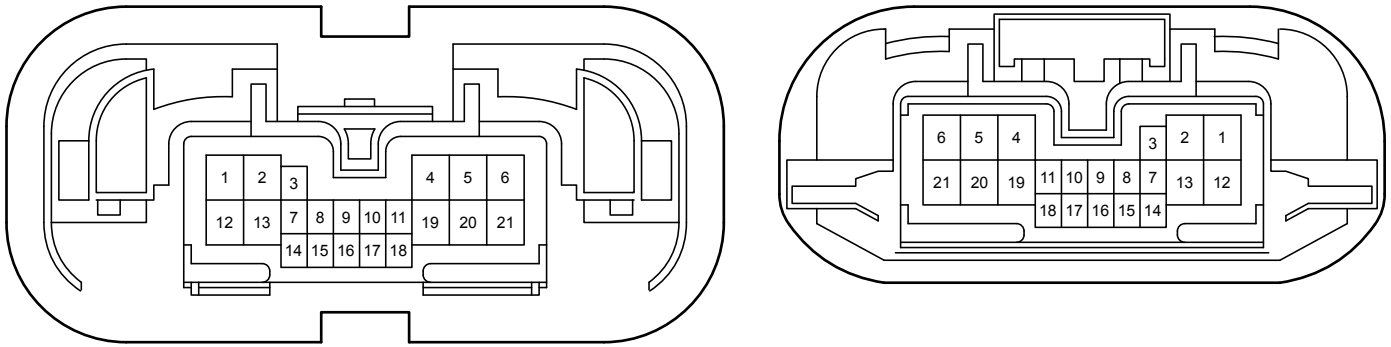

PK1  
Gray

QK1  
Black

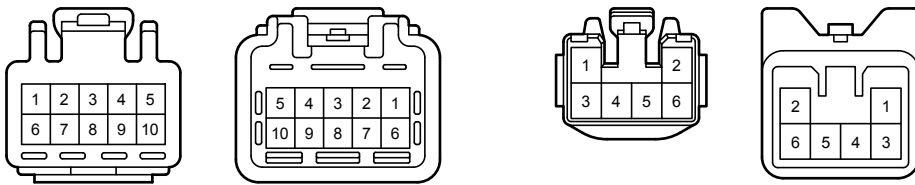

RA1  
White

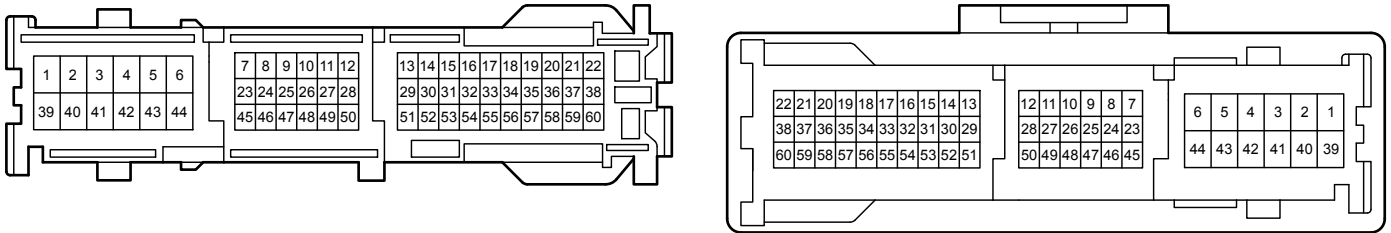

XR1  
White

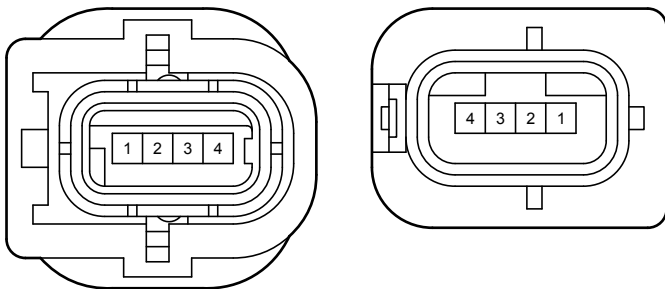

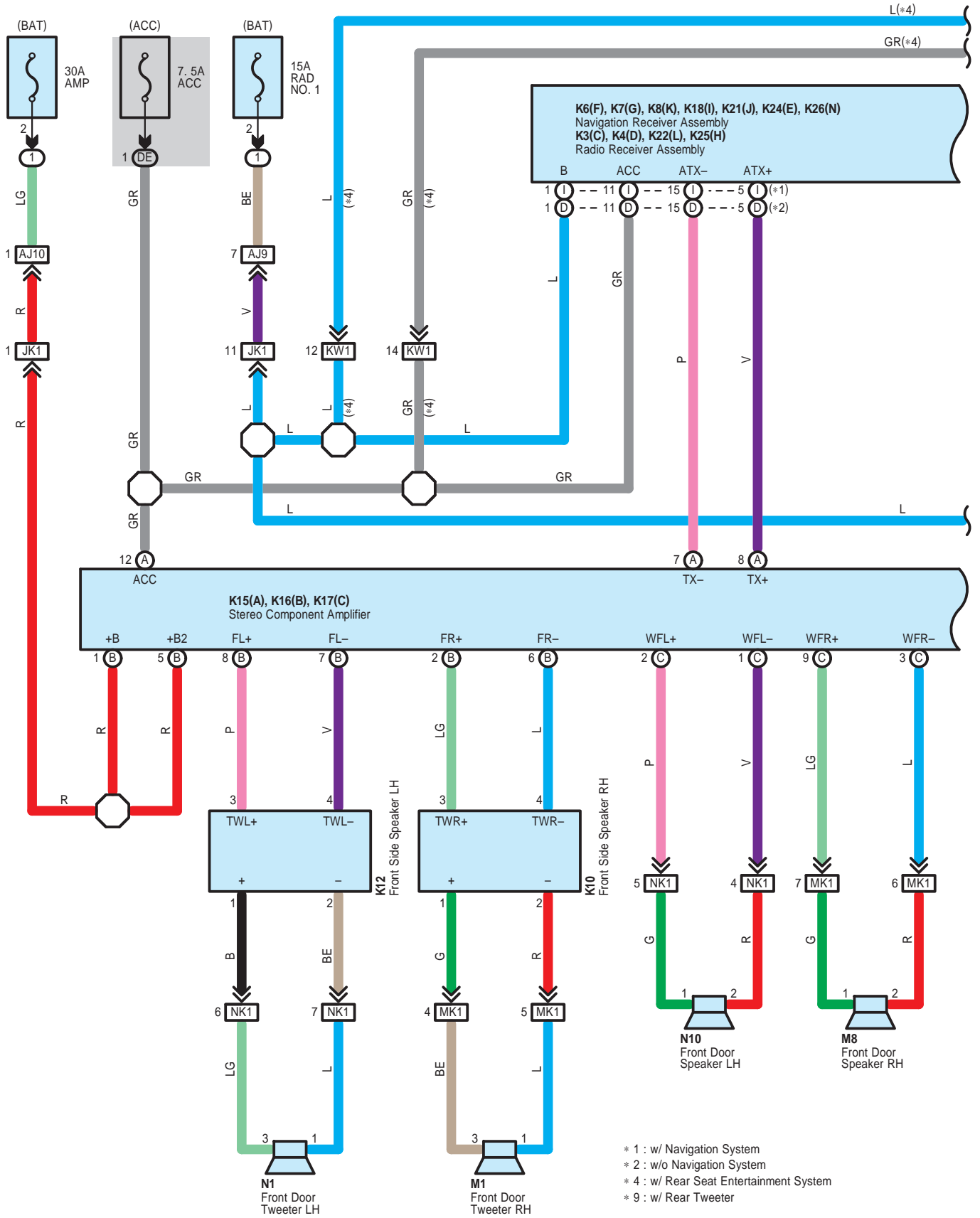

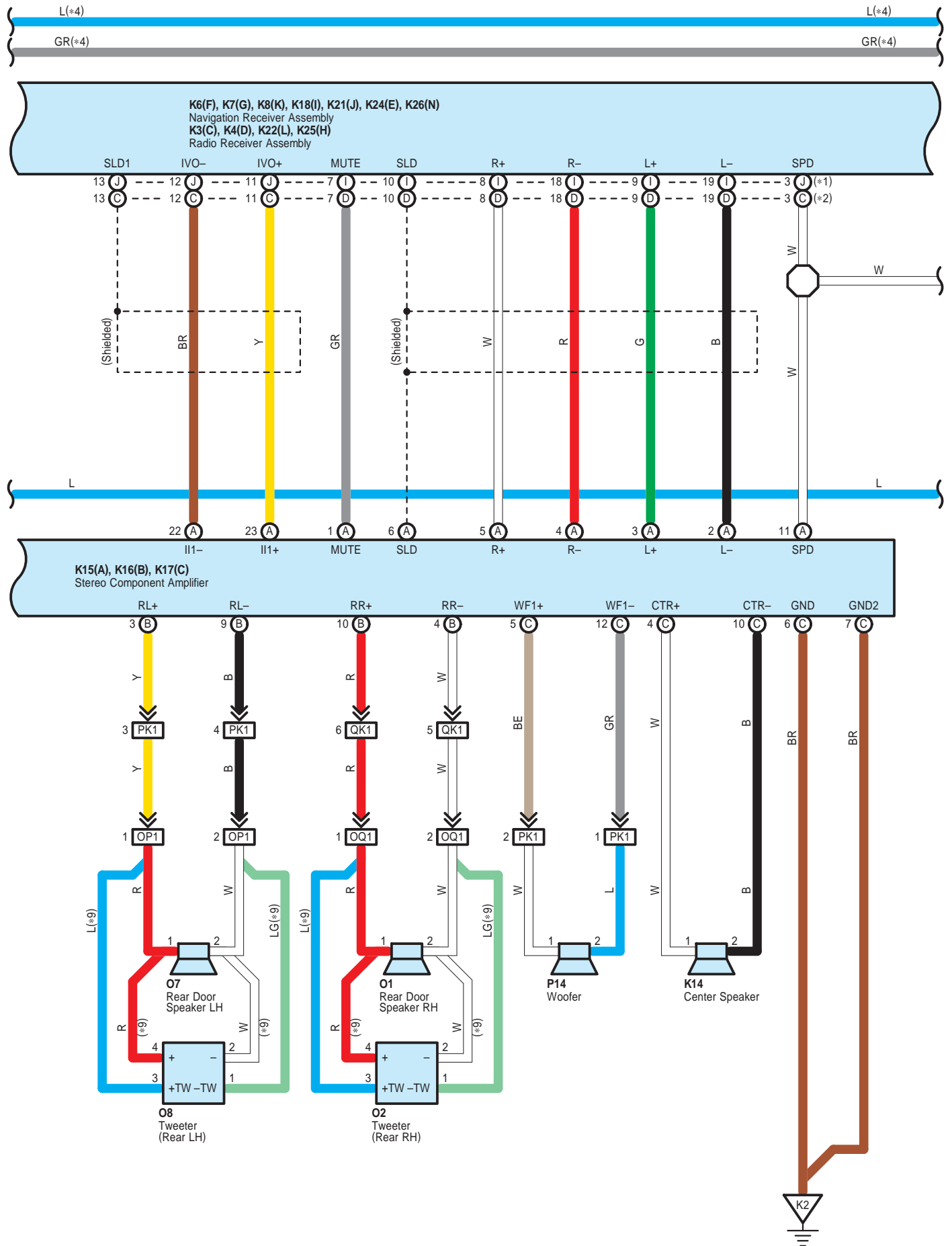

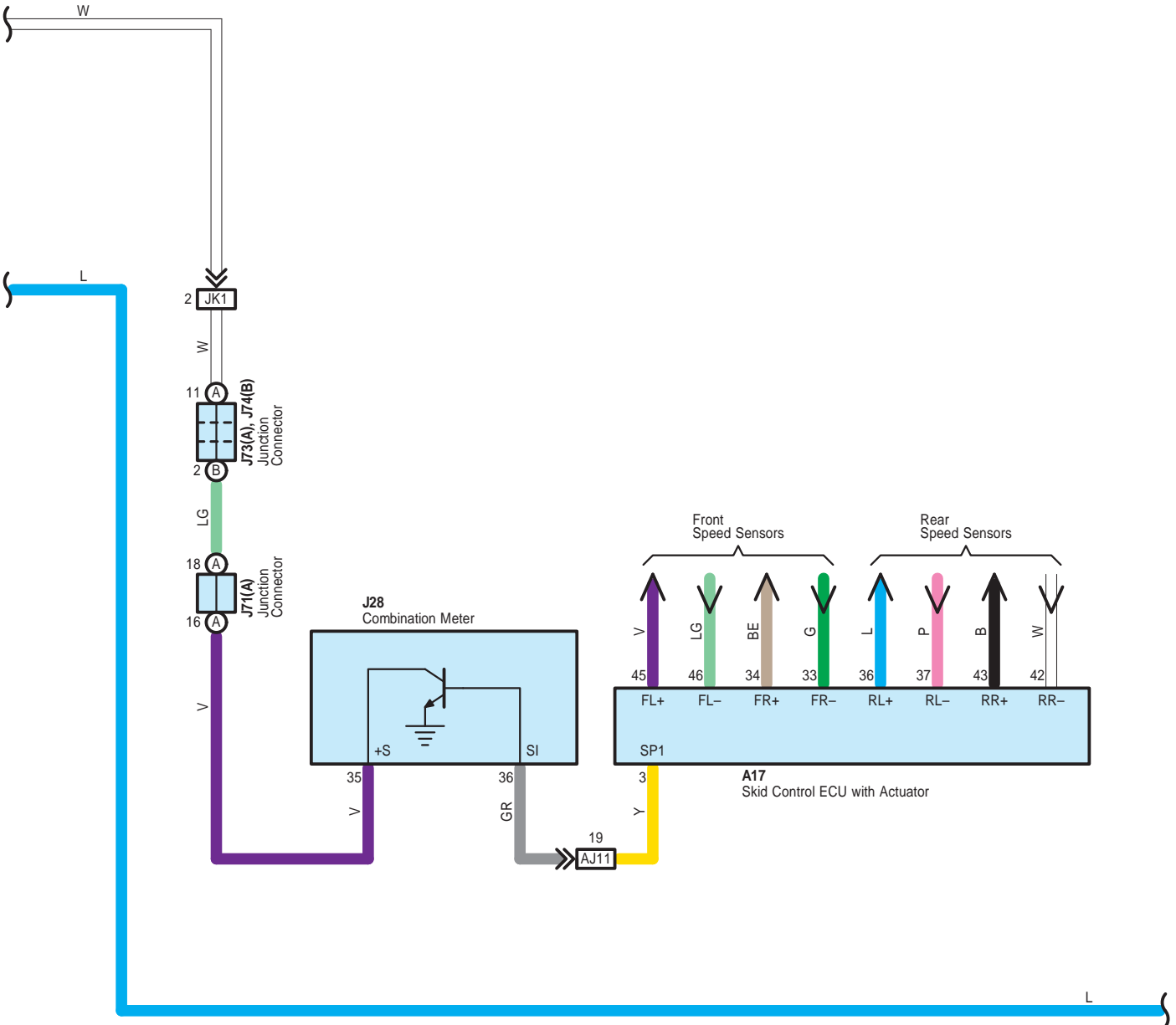
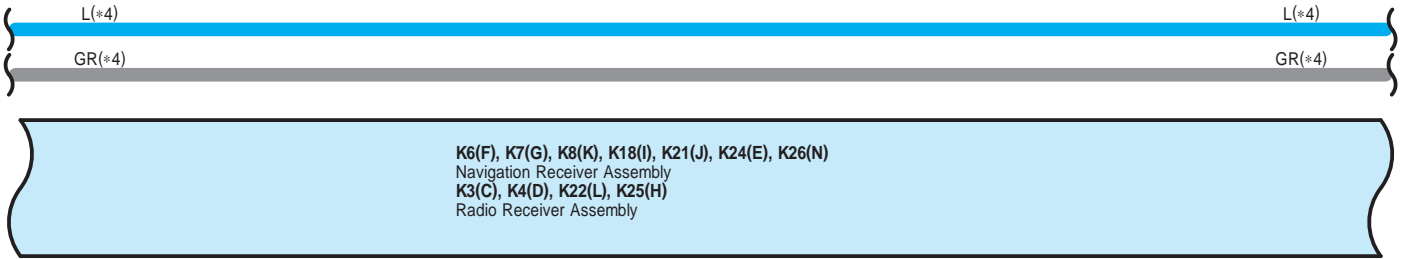

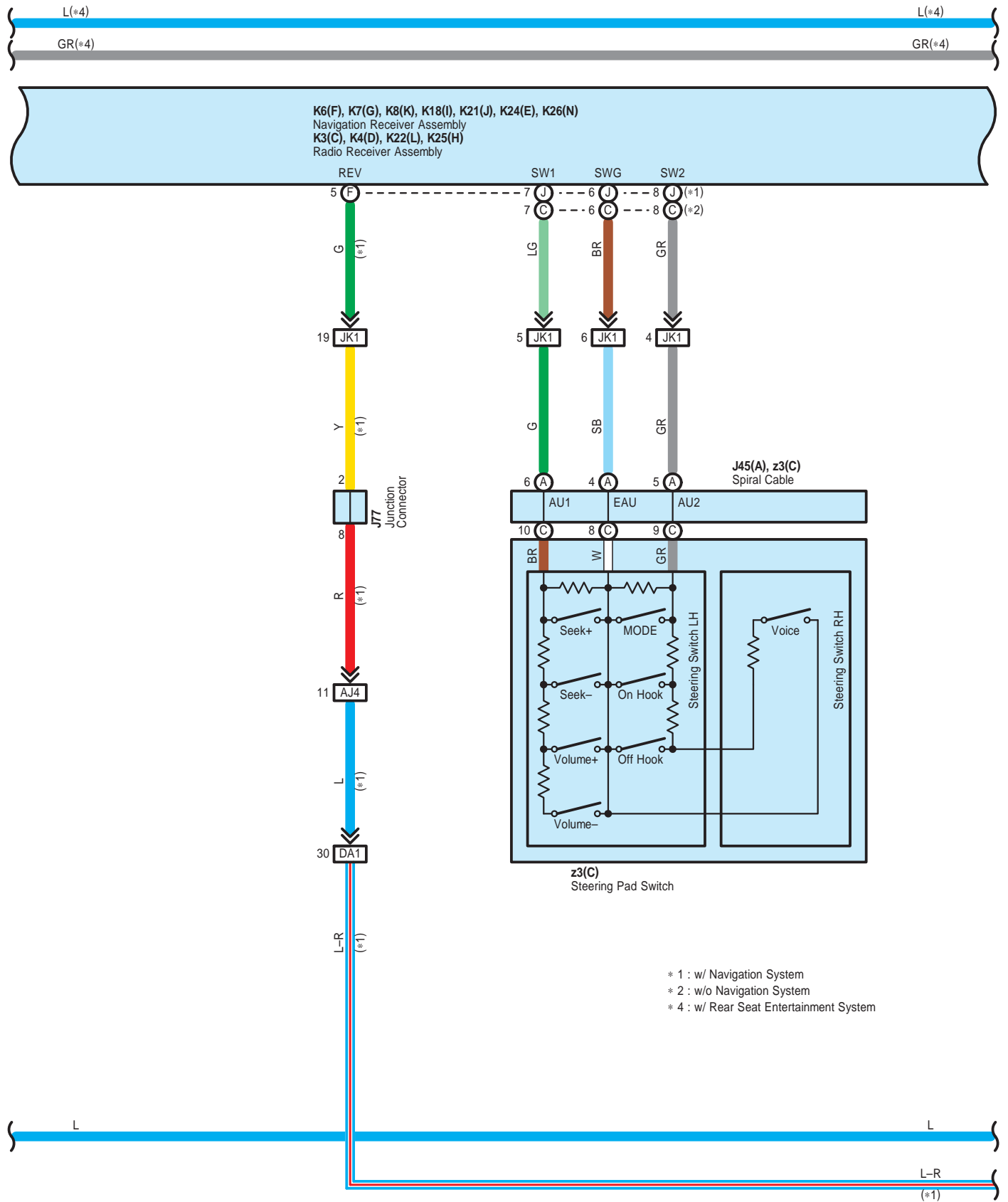

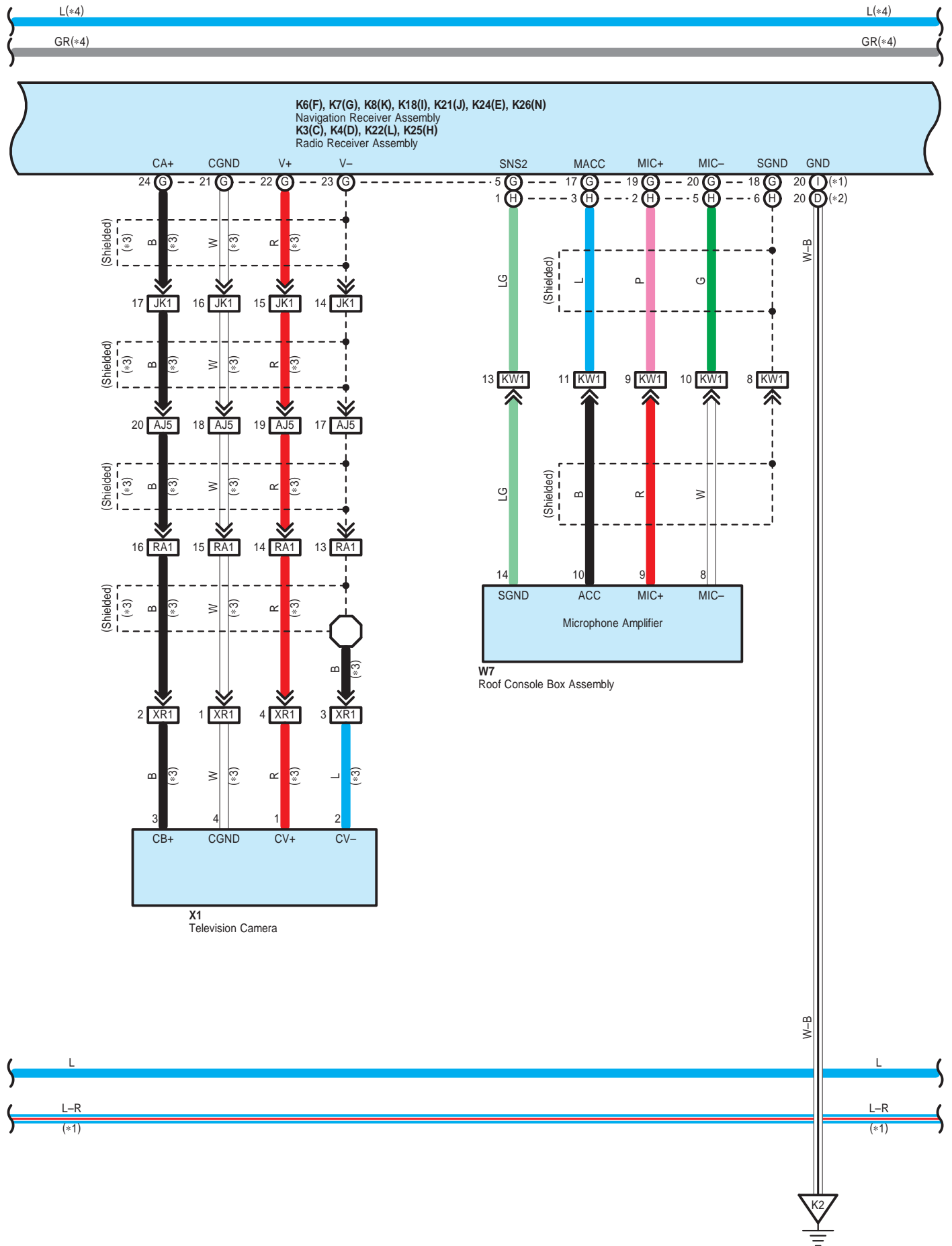

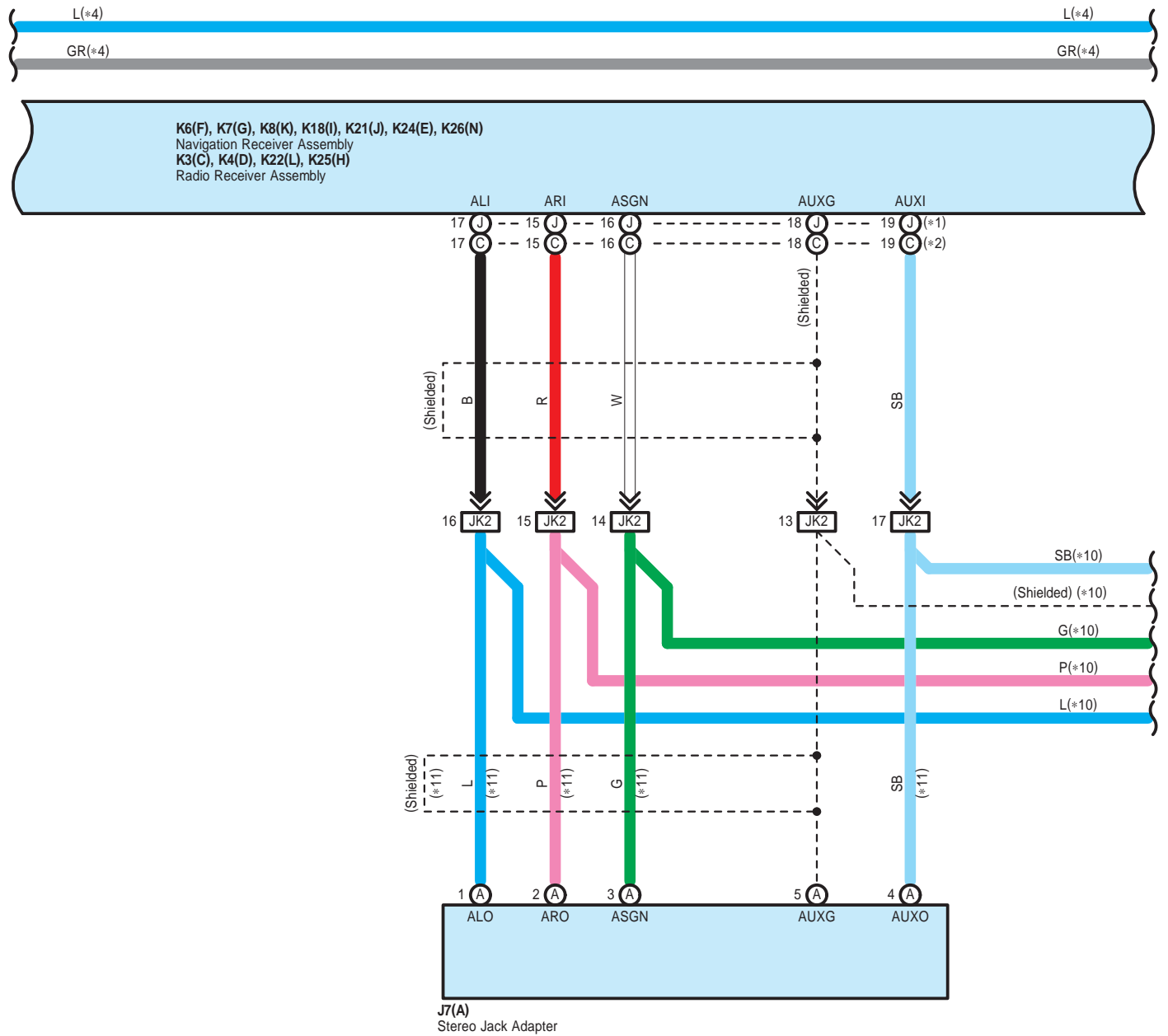

- \* 1 : w/ Navigation System
- \* 2 : w/o Navigation System
- \* 3 : w/ Rear View Monitor
- \* 4 : w/ Rear Seat Entertainment System
- \*10 : w/ Multi-Media Interface ECU
- \*11 : w/o Multi-Media Interface ECU



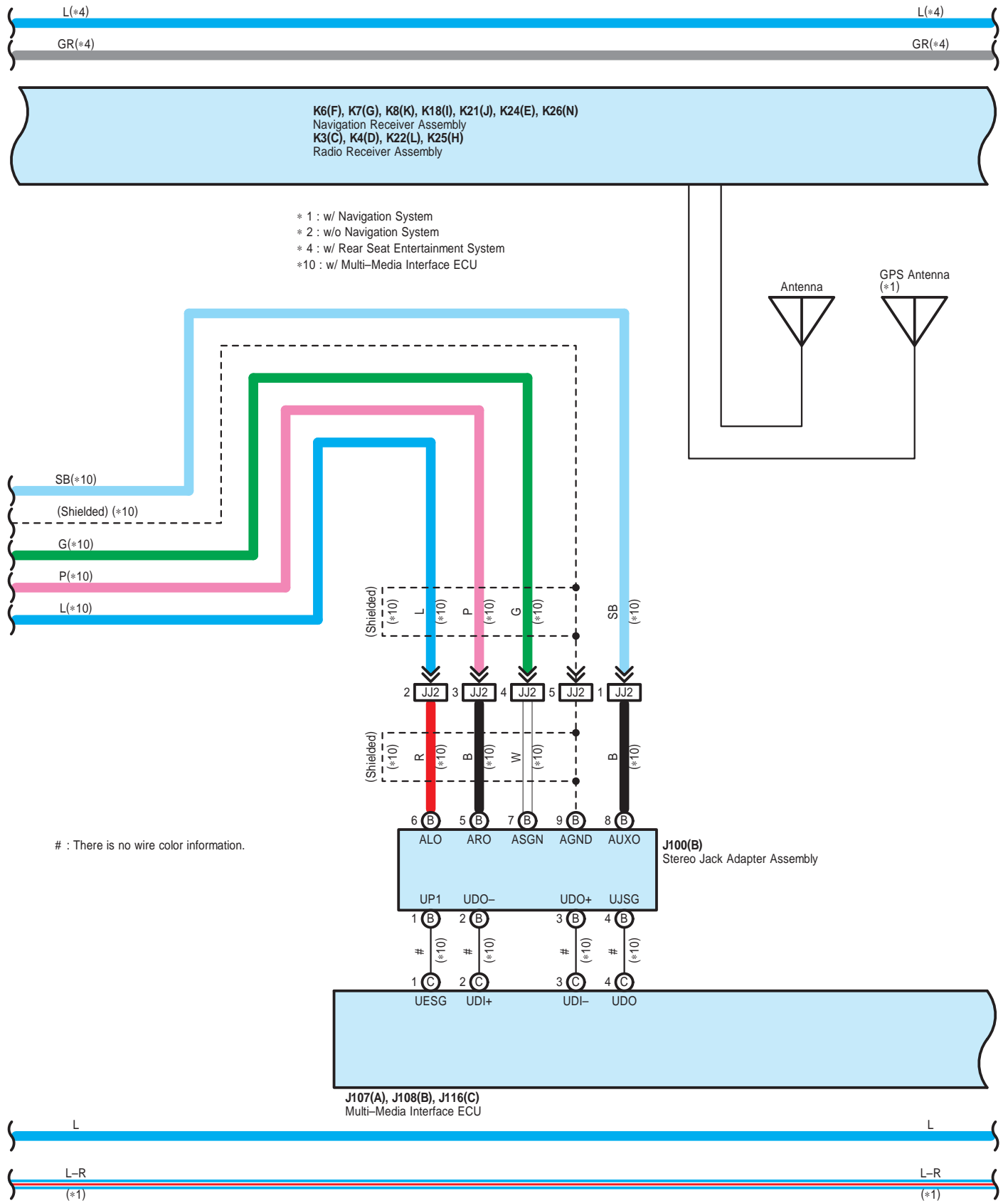



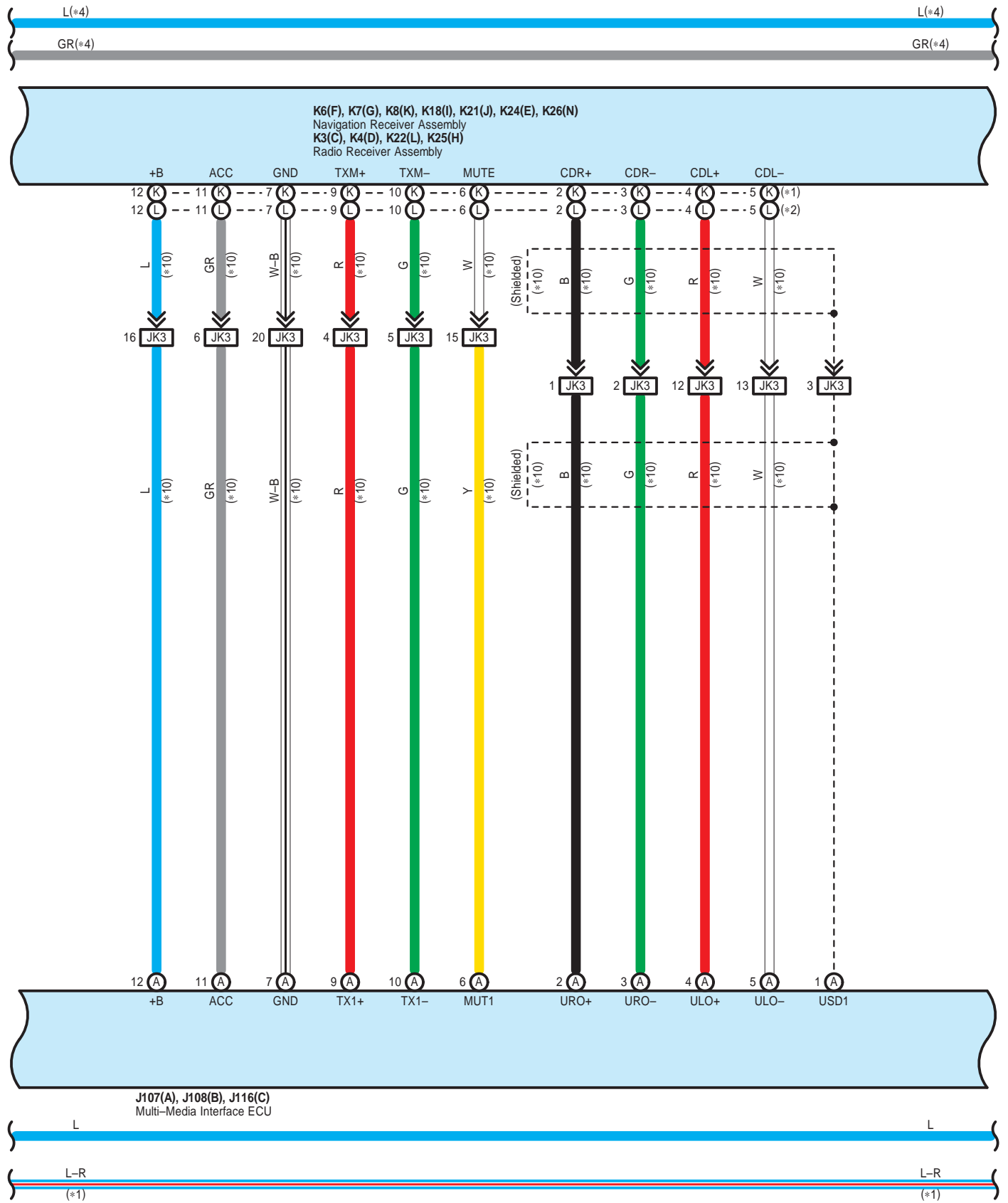

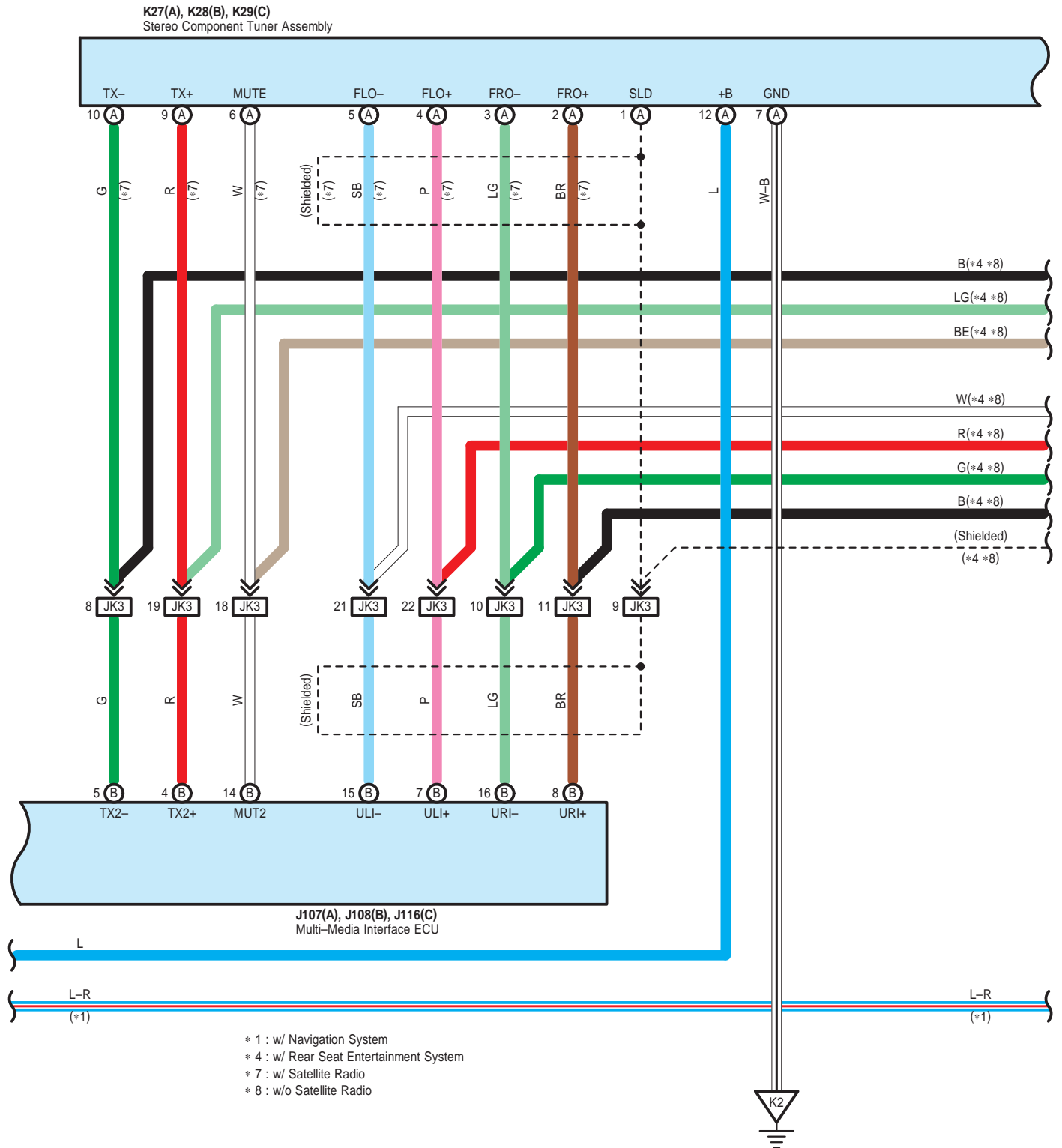
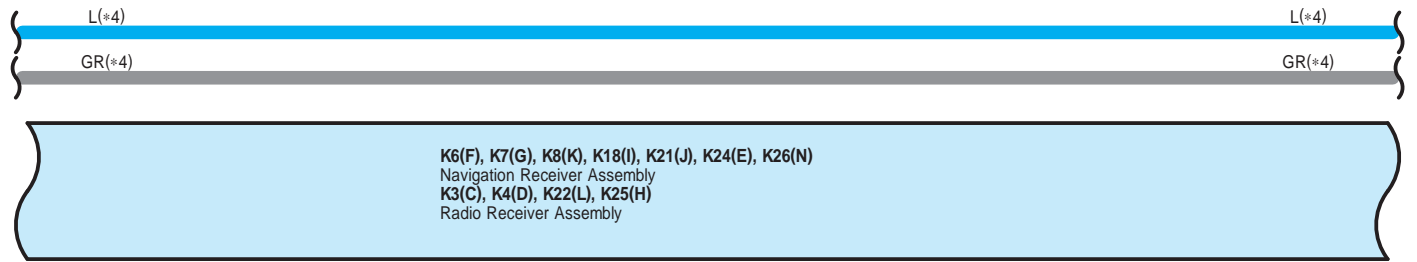

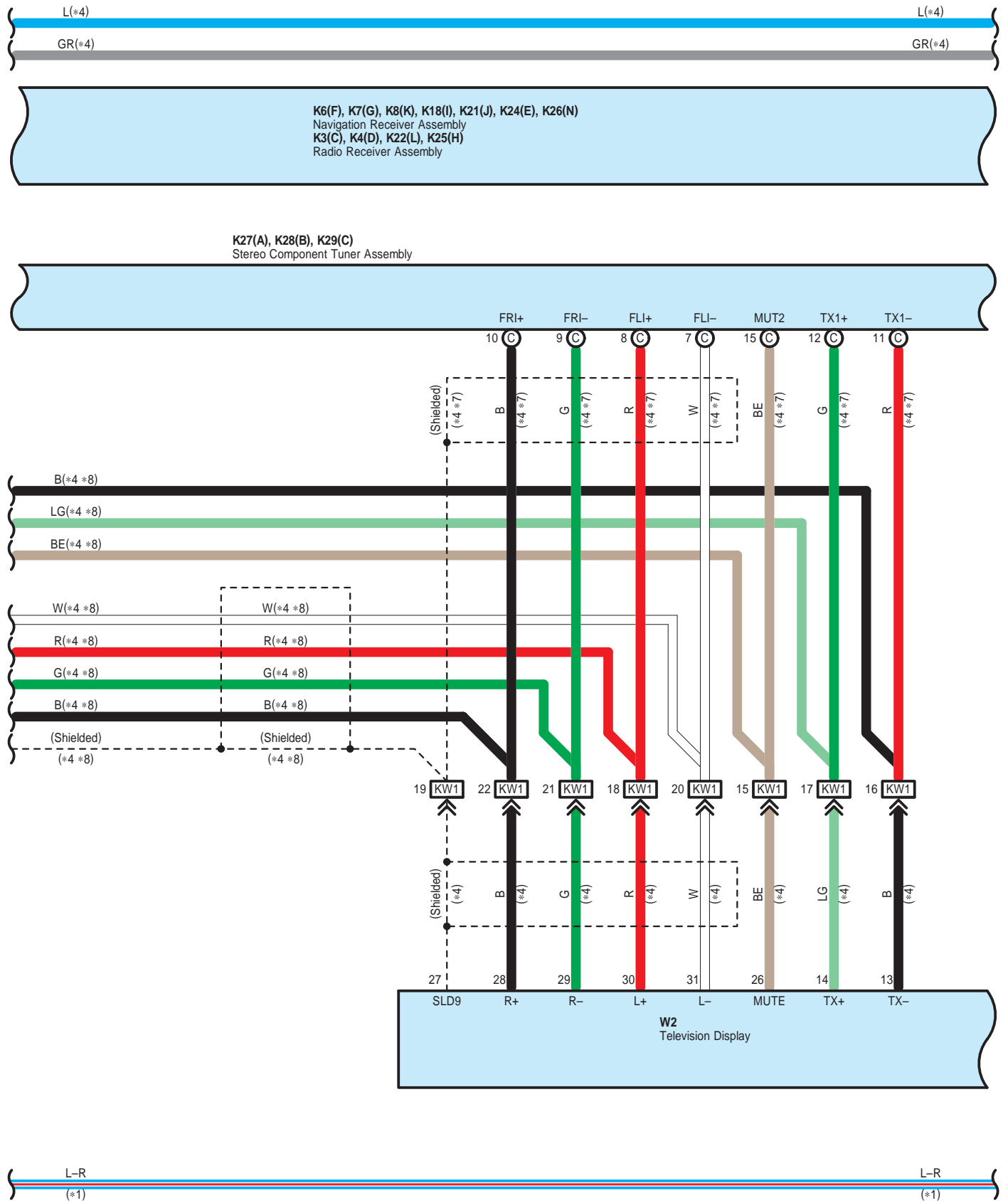

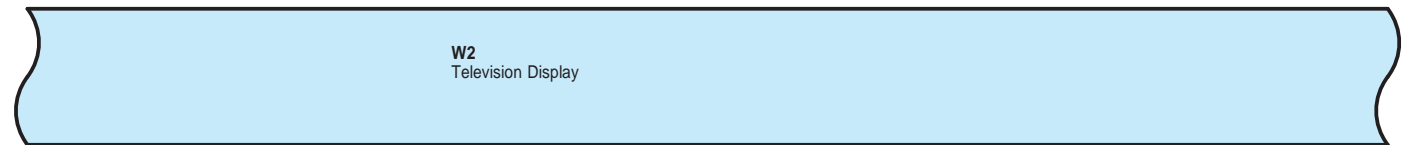
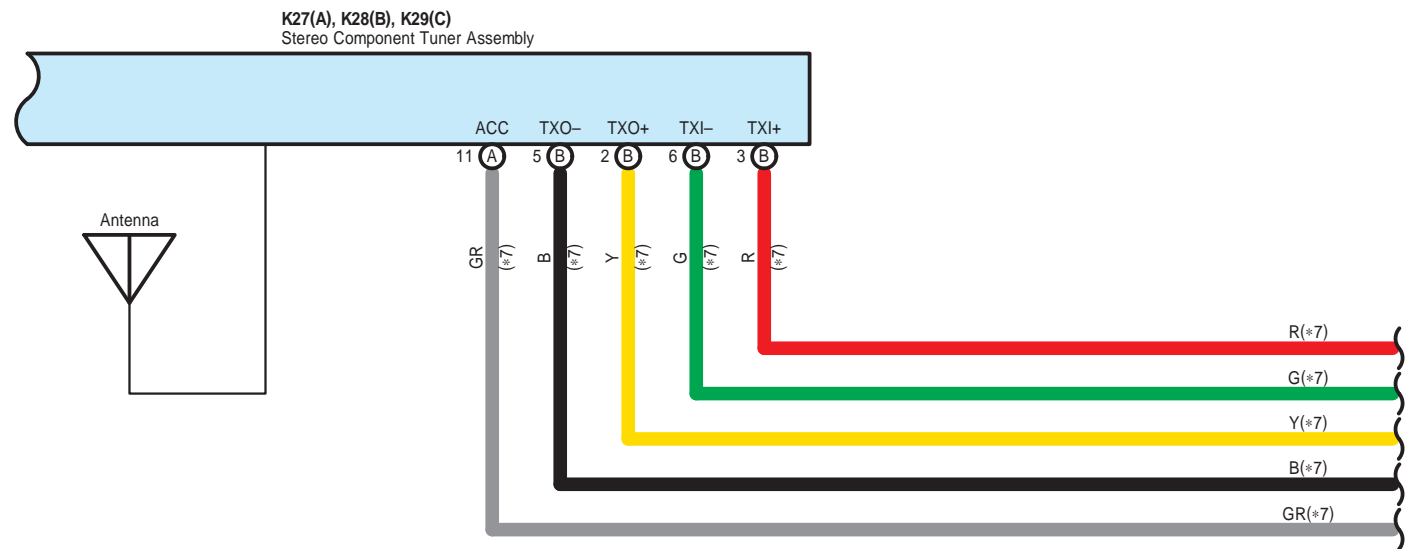
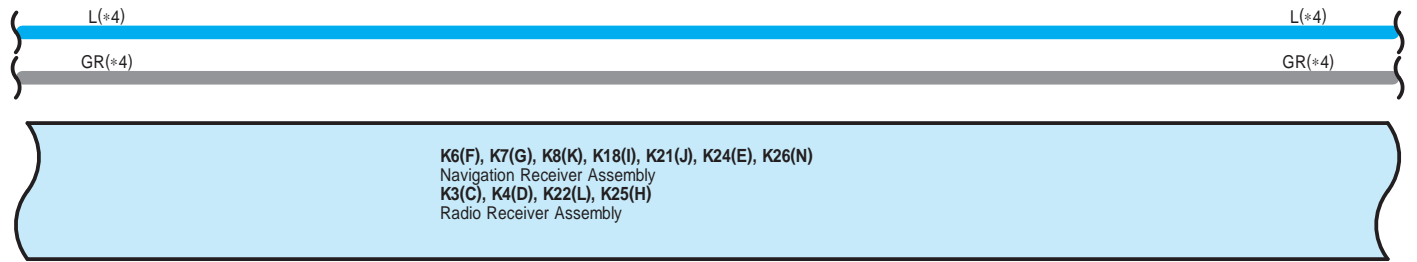

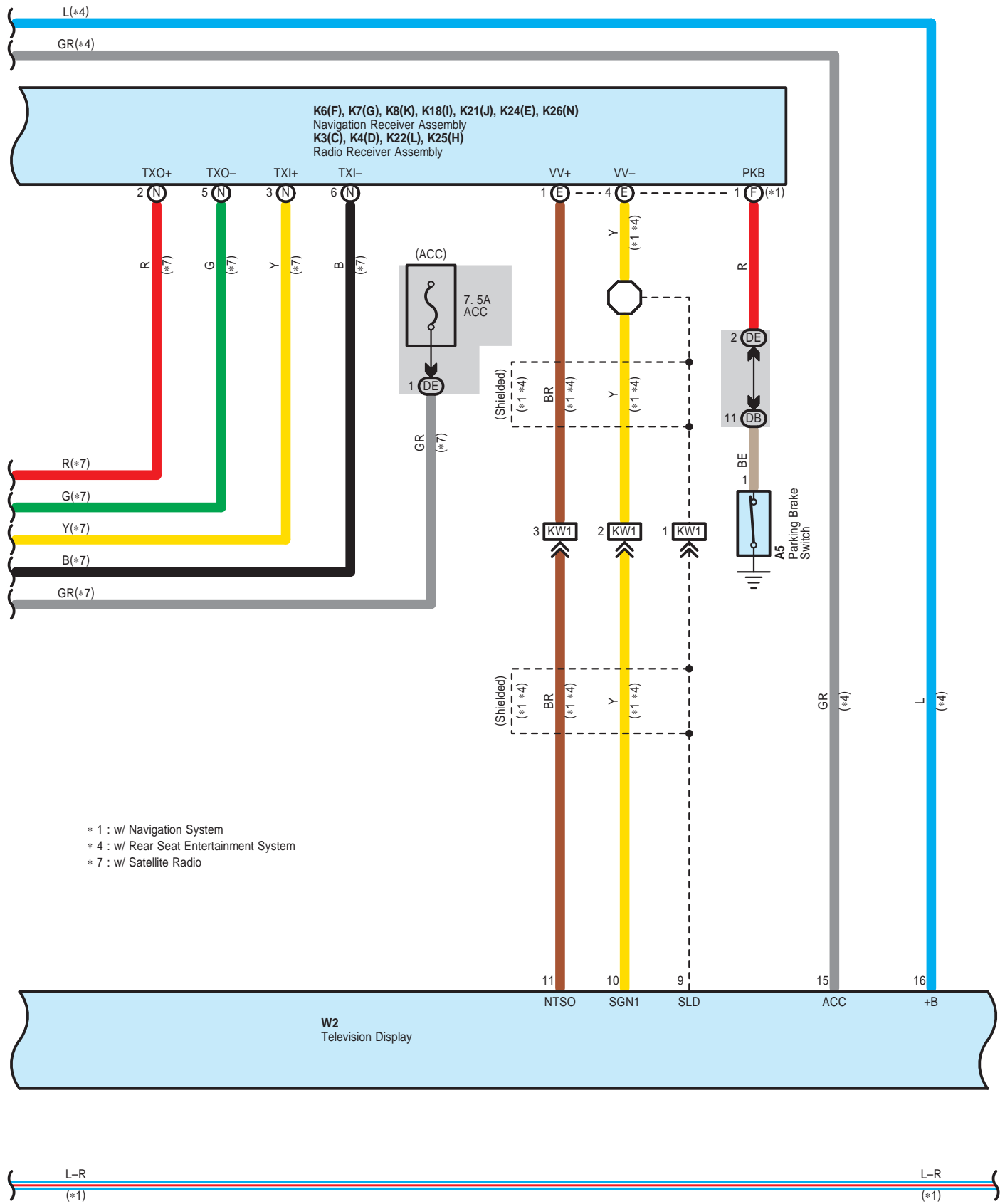

T4  
Video Terminal

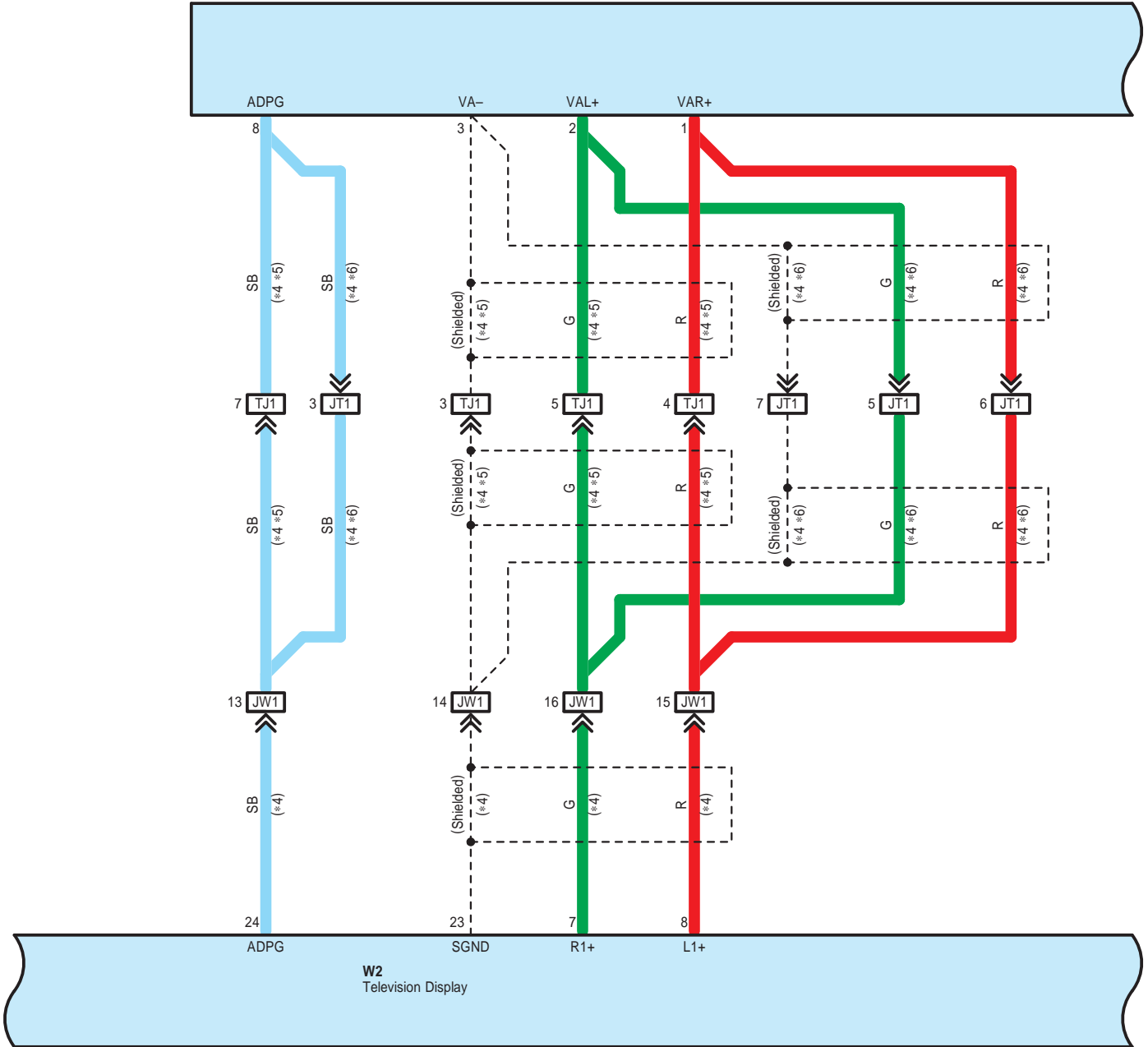

- \* 1 : w/ Navigation System
- \* 4 : w/ Rear Seat Entertainment System
- \* 5 : Floor Shift
- \* 6 : Column Shift

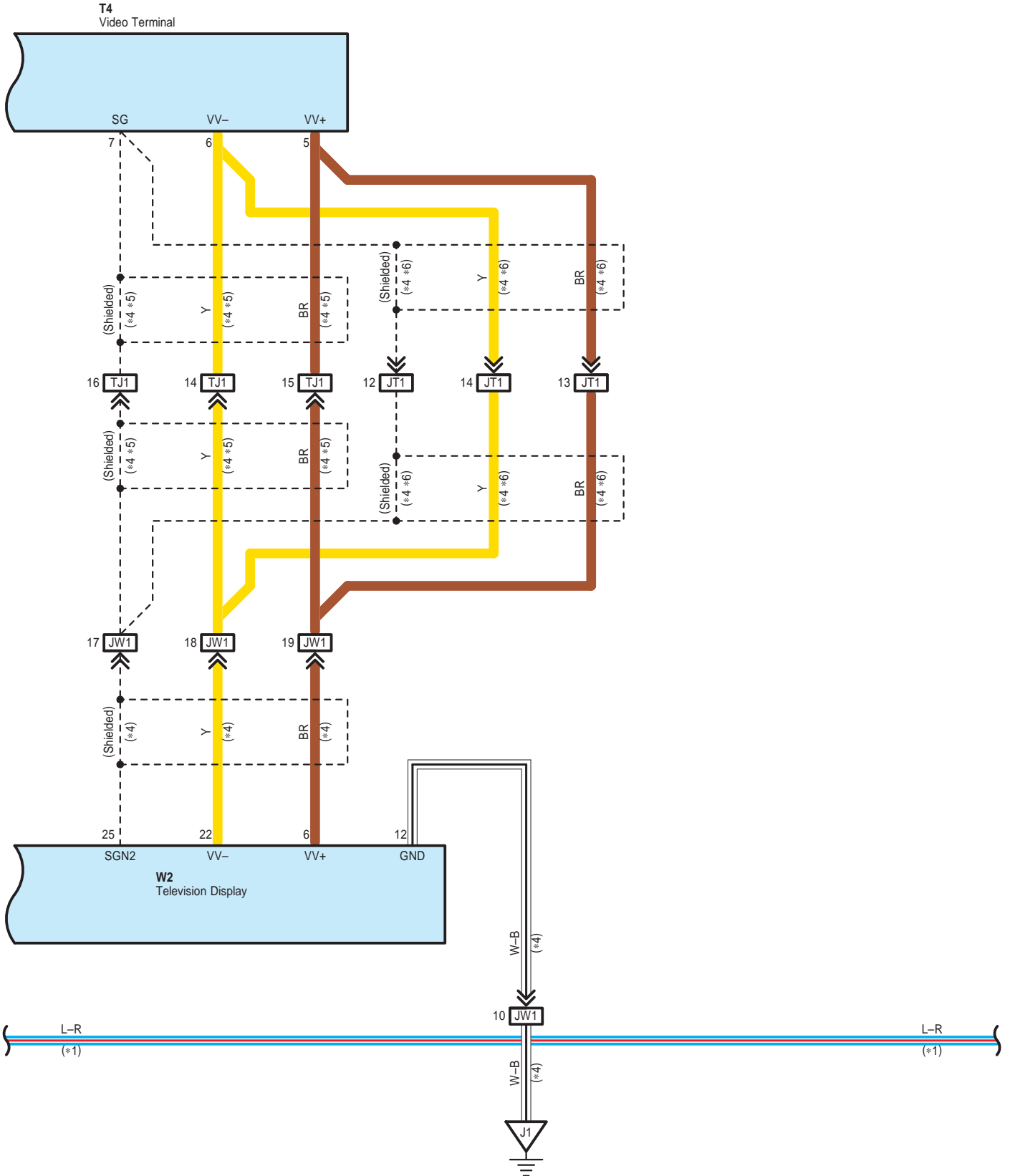





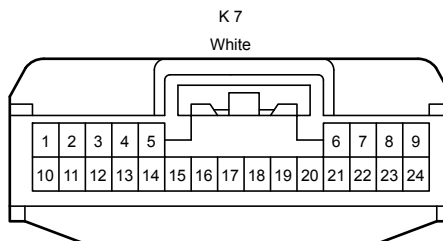
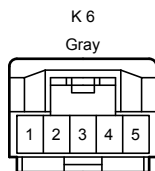
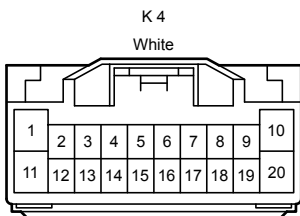
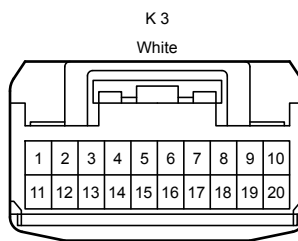
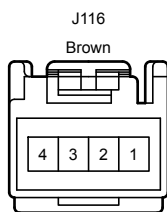
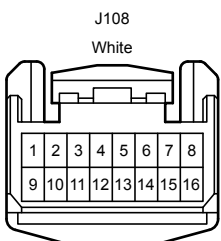
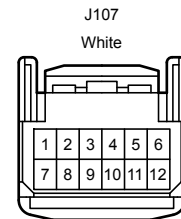
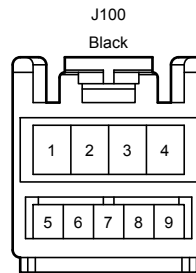
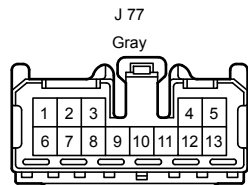
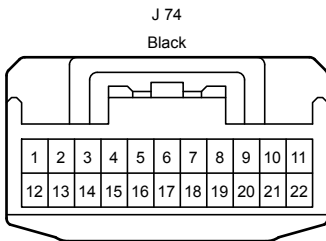
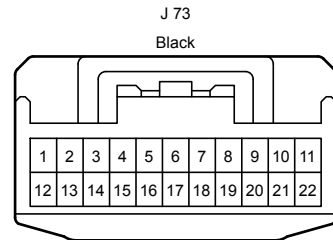
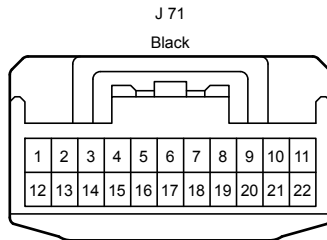
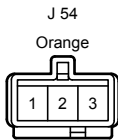
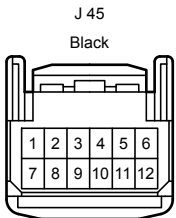
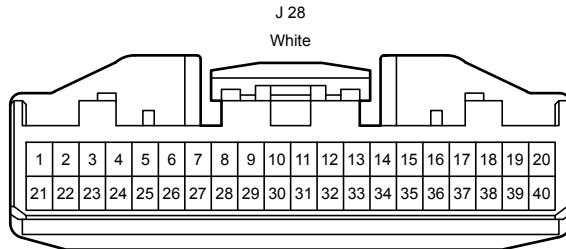
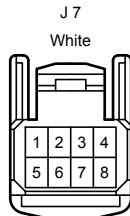
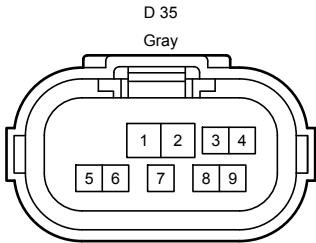
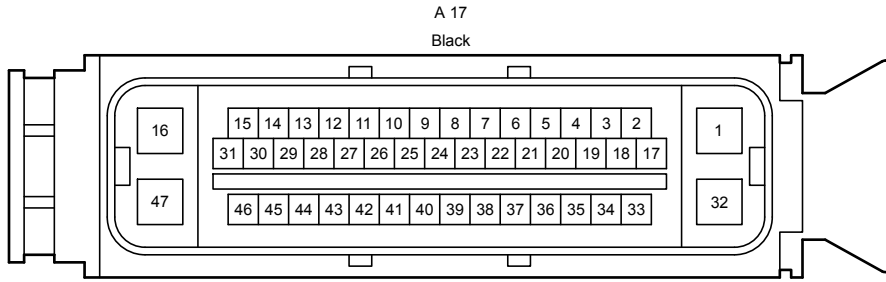

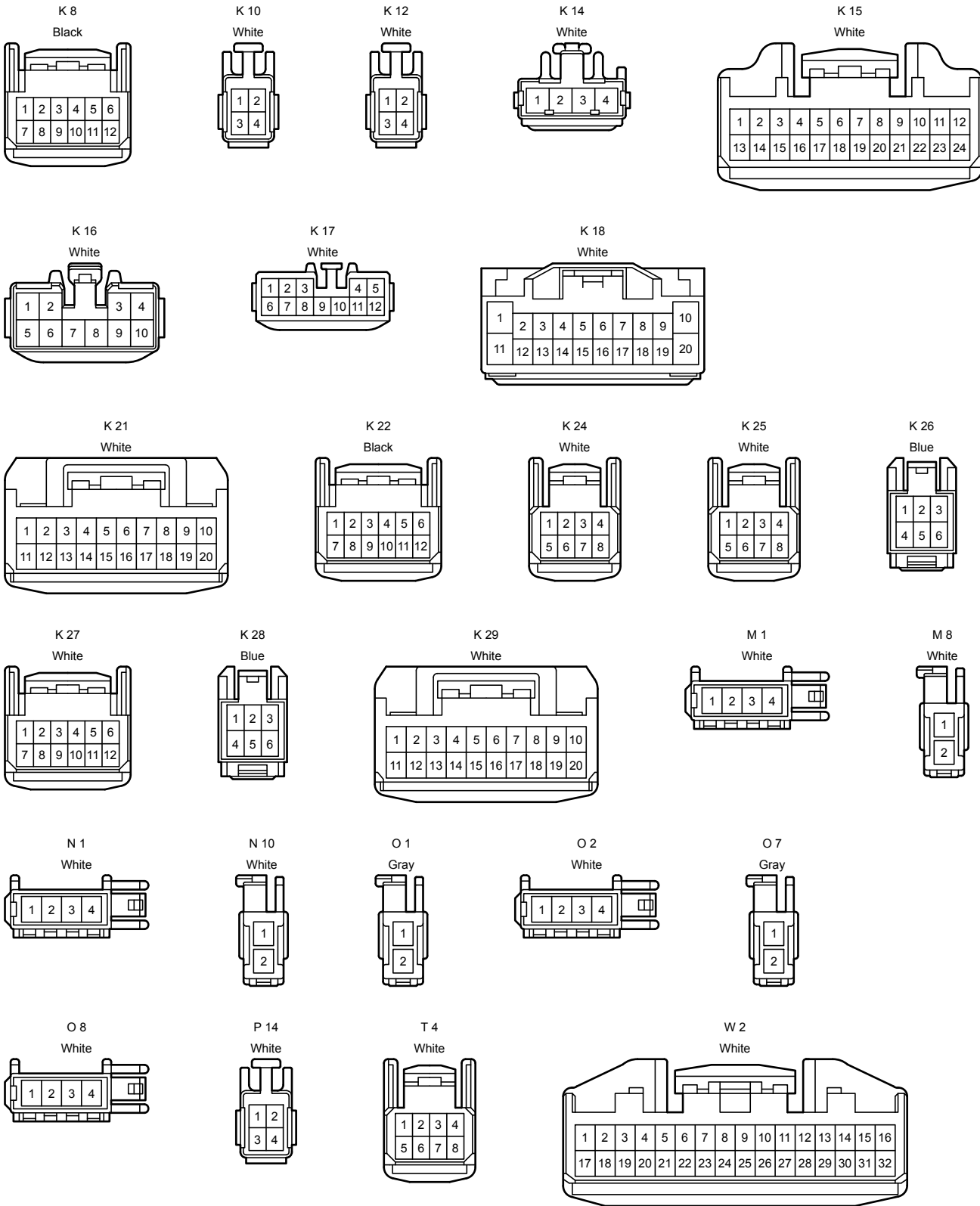

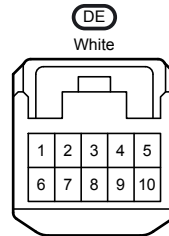
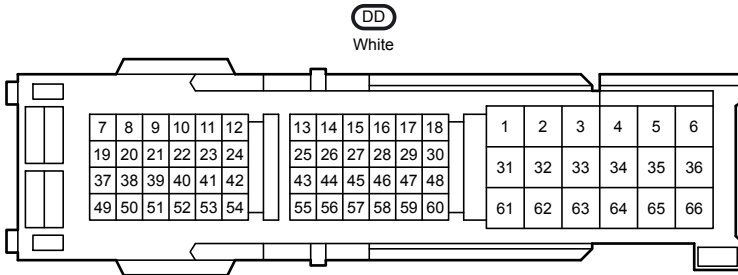
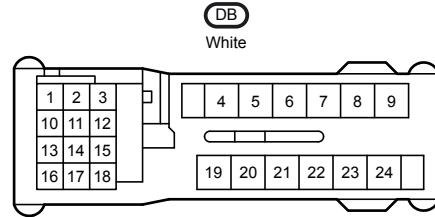
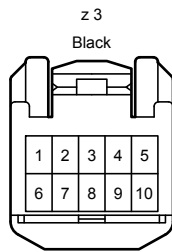
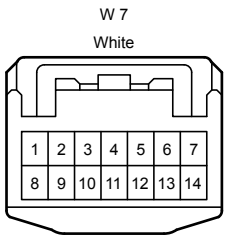

AJ4  
White

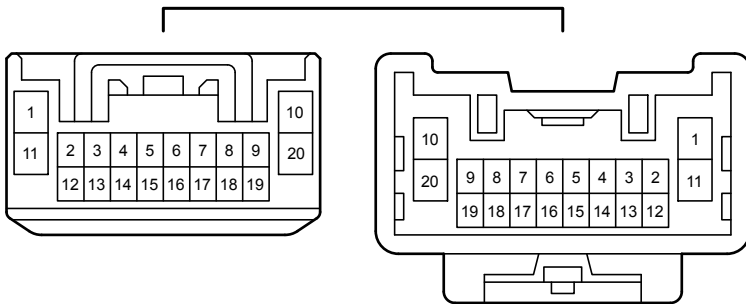

AJ5  
White

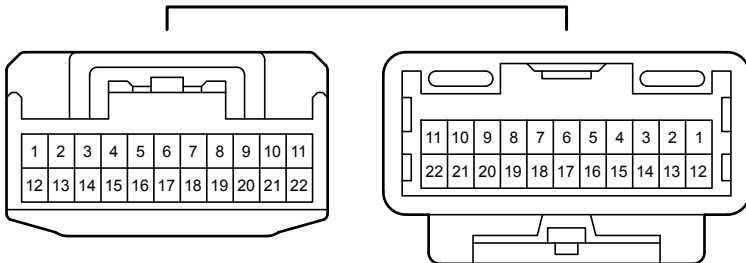

AJ9  
Gray

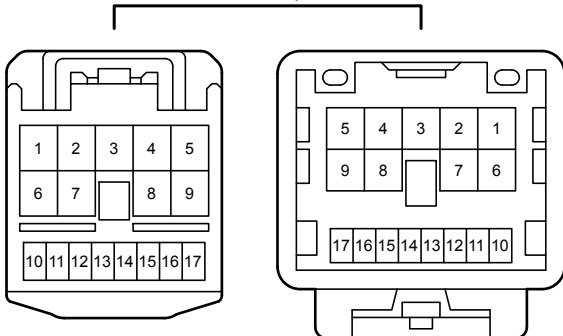

AJ10  
Gray

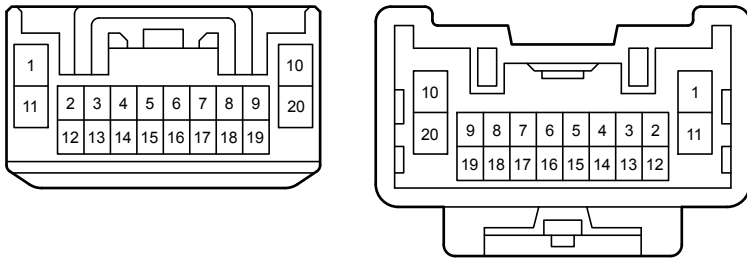

AJ11  
Gray

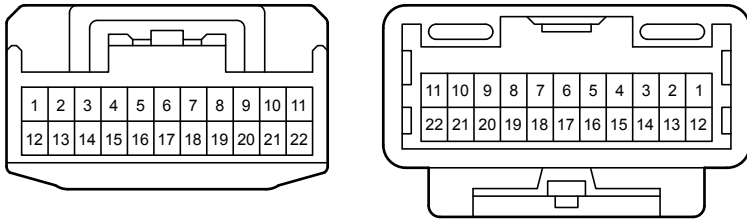

DA1  
White

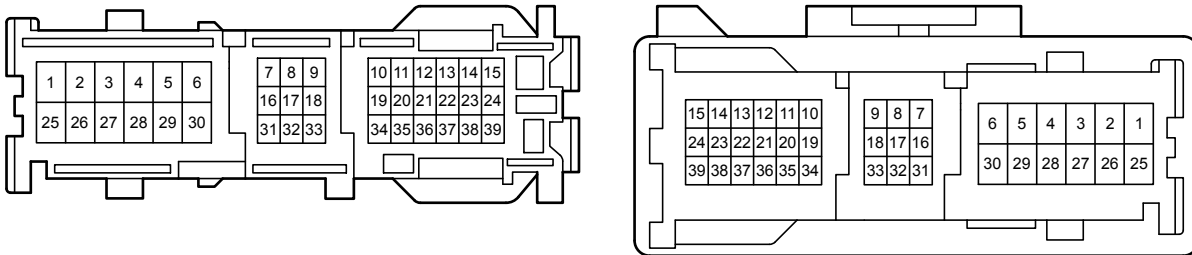

JJ2  
White

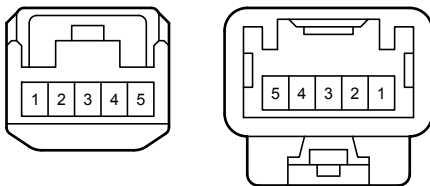

JK1  
White

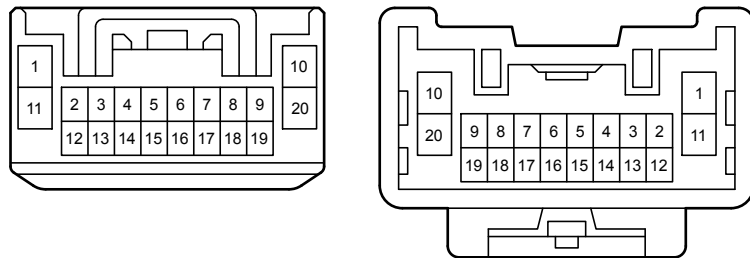

JK2  
White

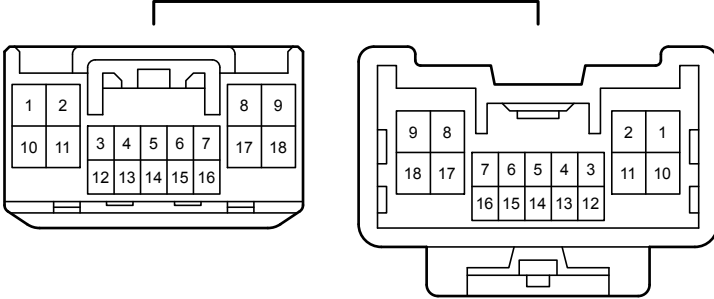

JK3  
White

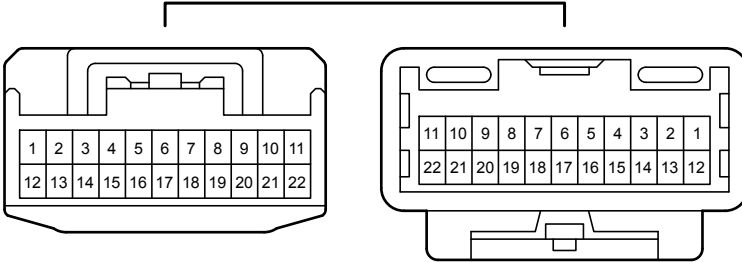

JT1  
Black

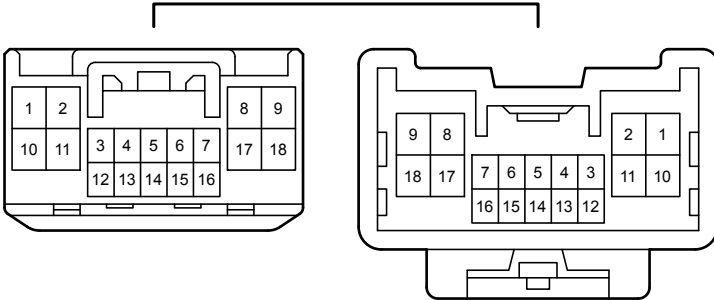

JW1  
White

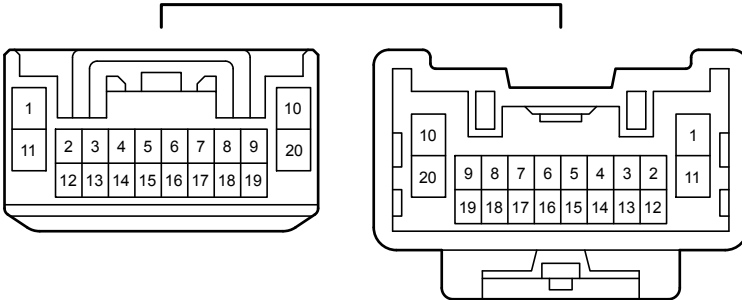

KW1  
White

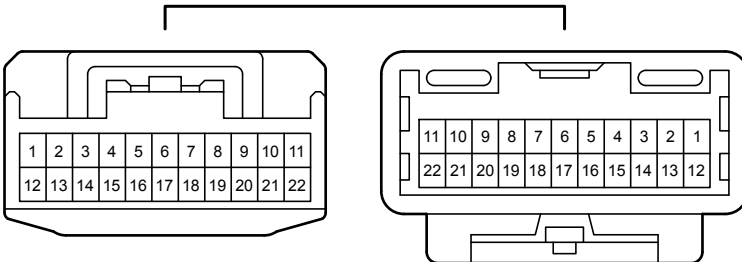

MK1  
Blue

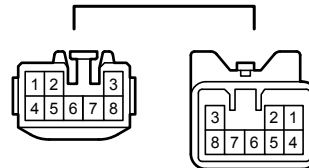

NK1  
Blue

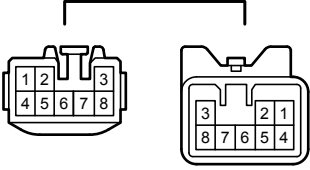

OP1  
White

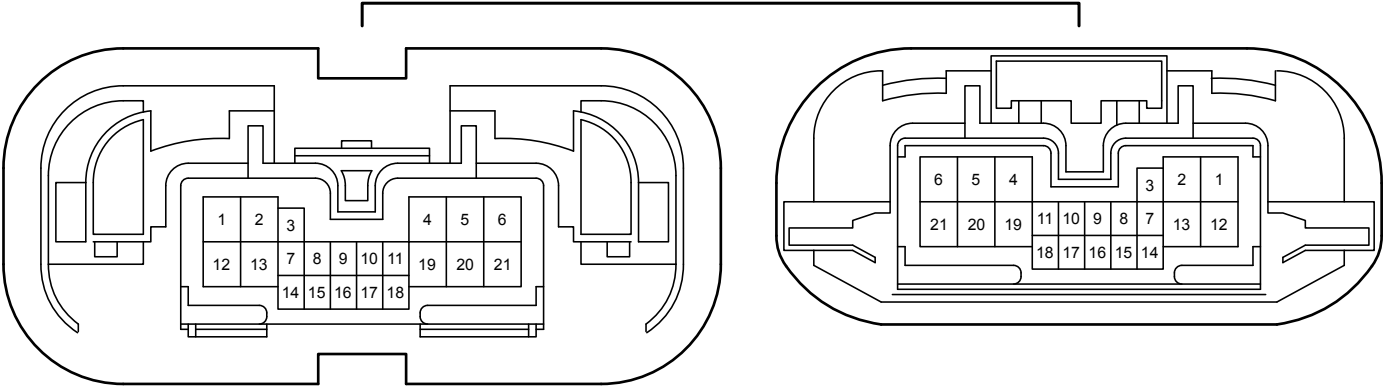

OQ1  
White

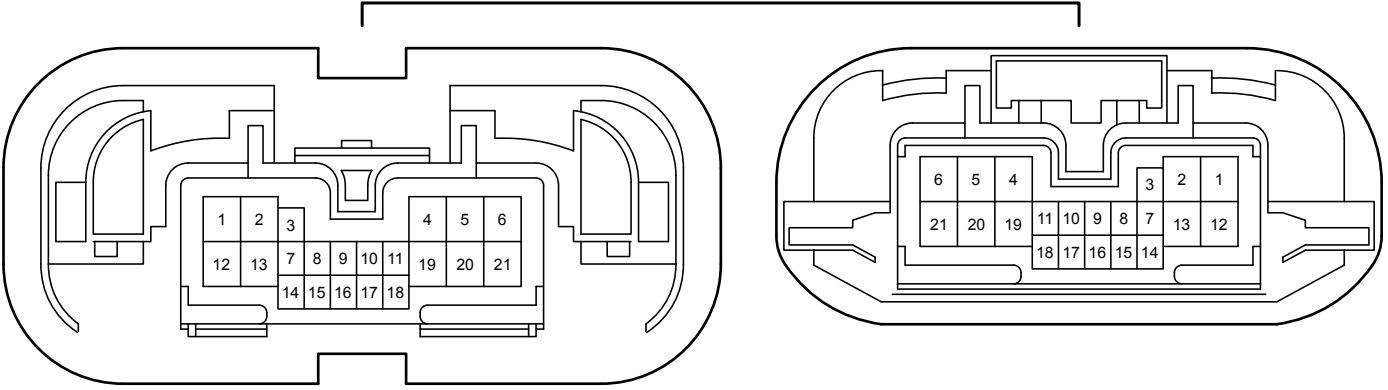

PK1  
Gray

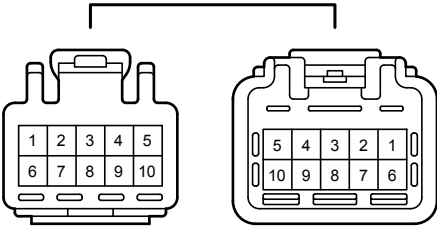

QK1  
Black

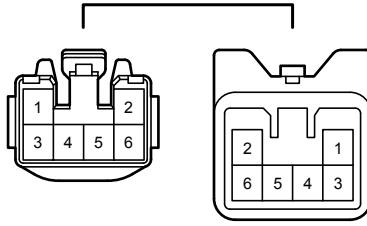

RA1  
White

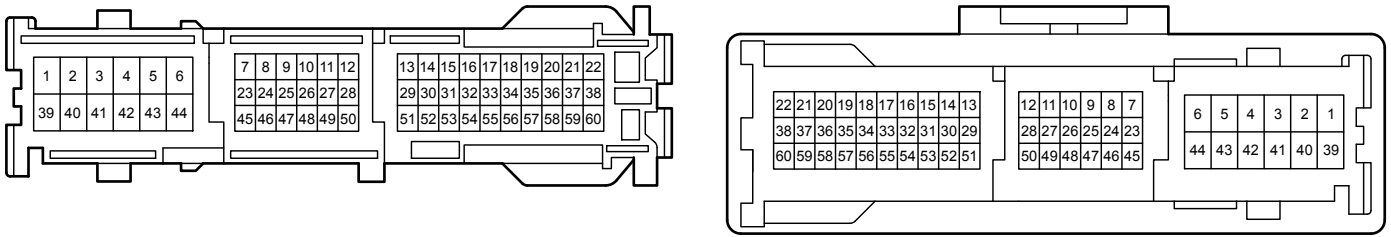

TJ1  
White

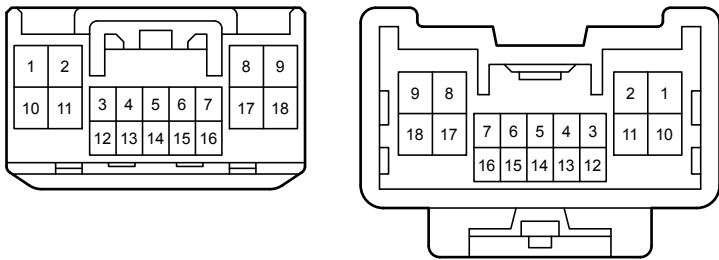

XR1  
White

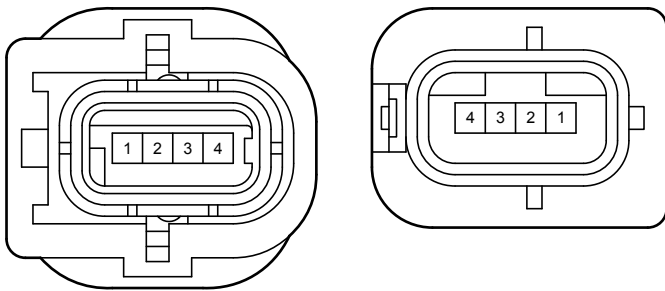

# Back-Up Light

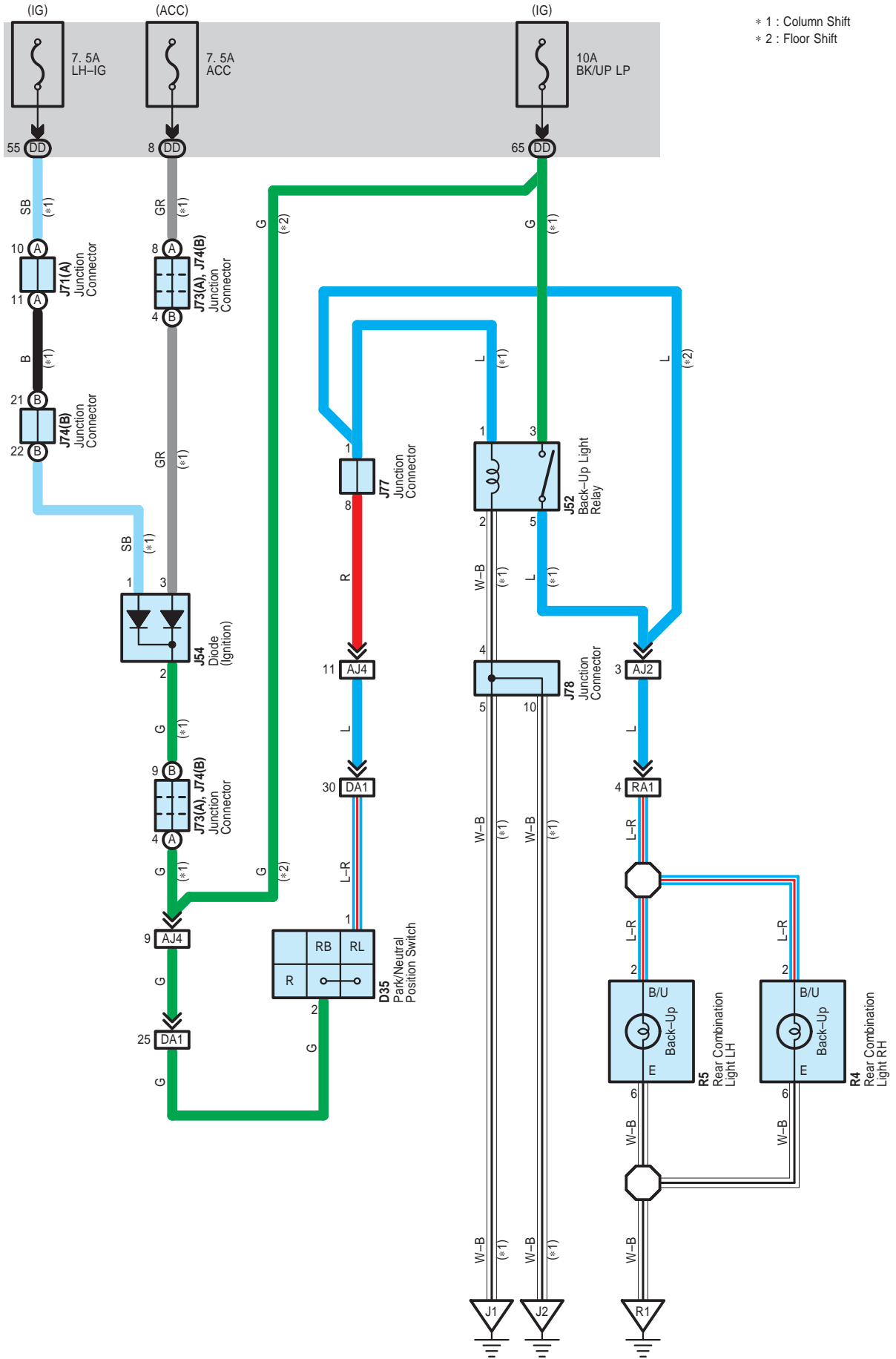





Back-Up Light

DA1  
White

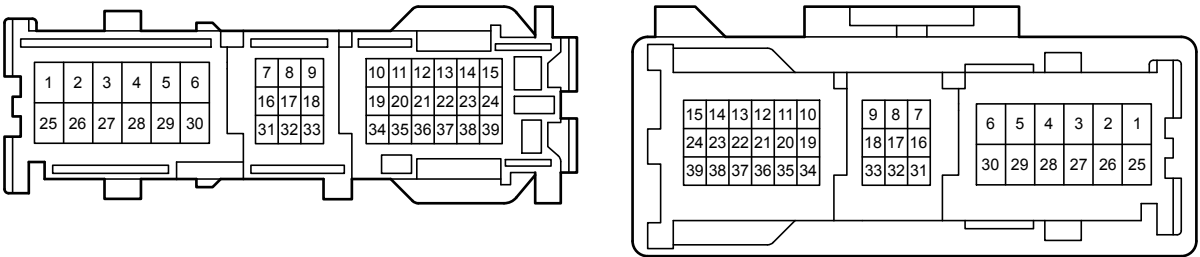

RA1  
White

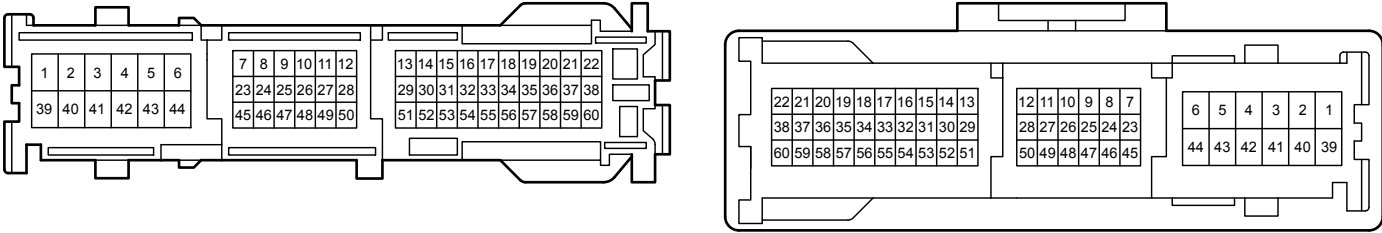

# Cargo Light

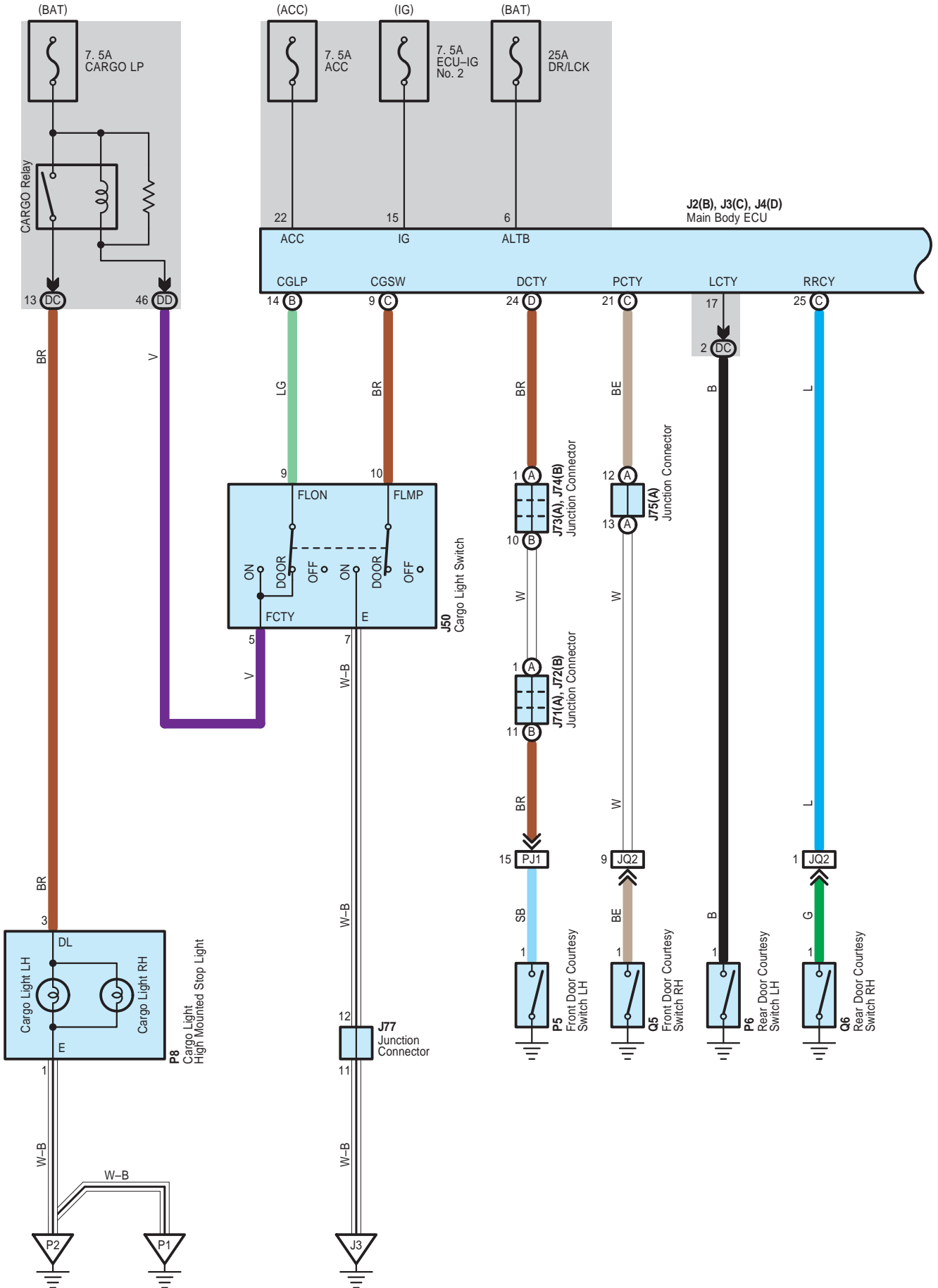

Cargo Light

\* 1 : w/ Power Seat  
 \* 2 : w/o Power Seat

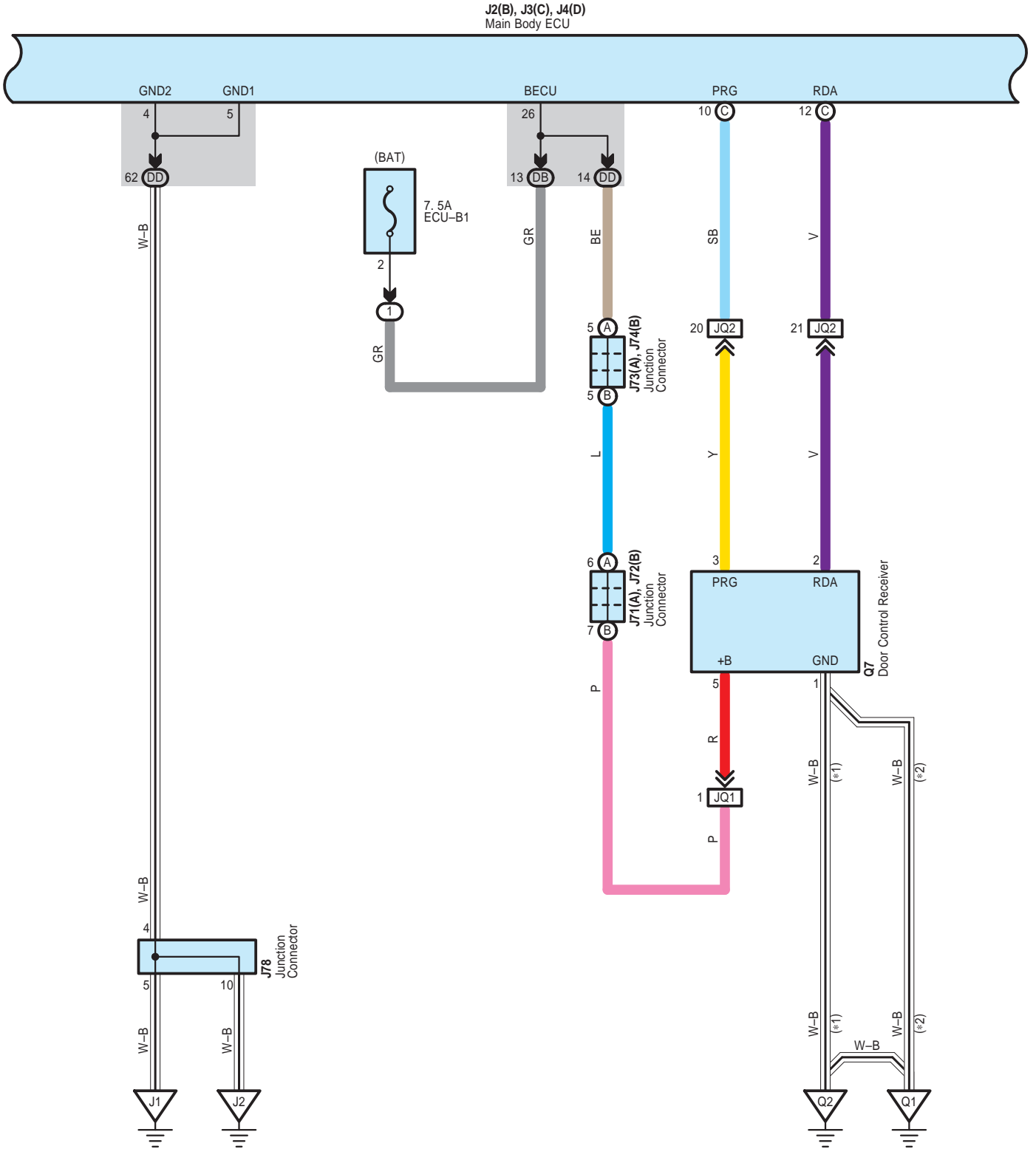

Cargo Light

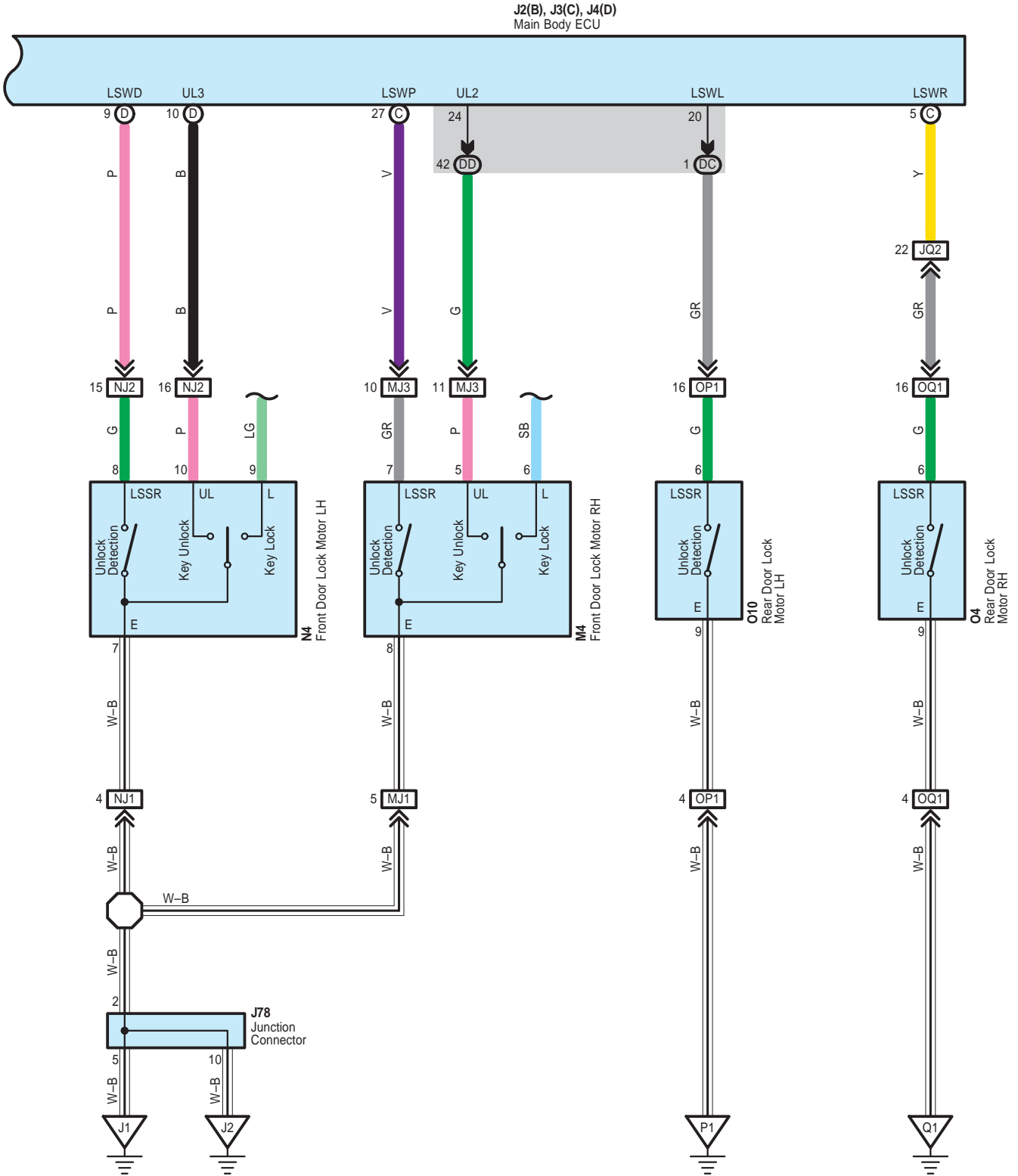

Cargo Light

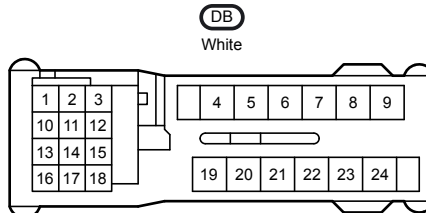
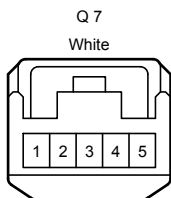
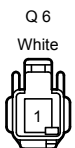
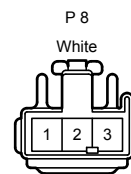
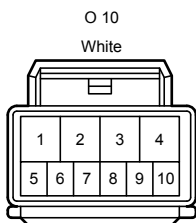
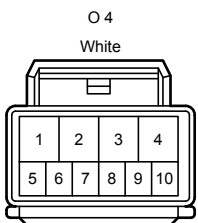
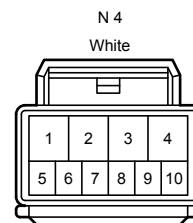
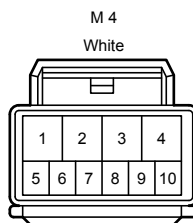
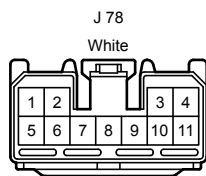
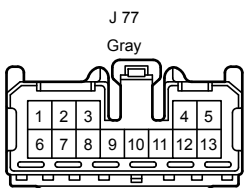
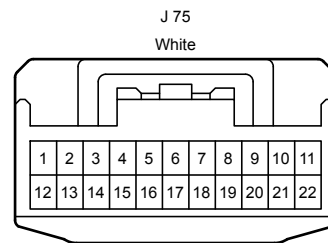
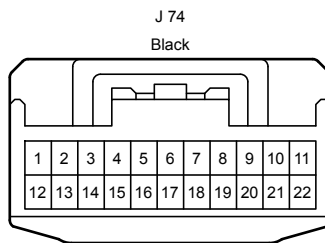
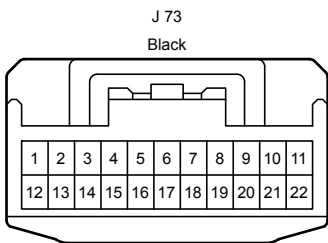
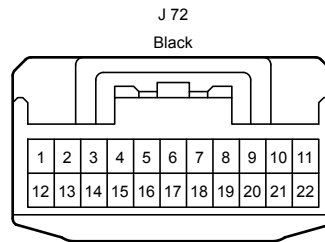
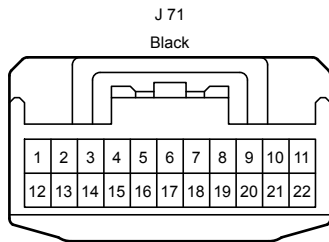
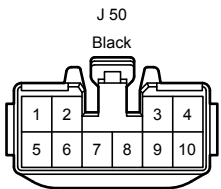
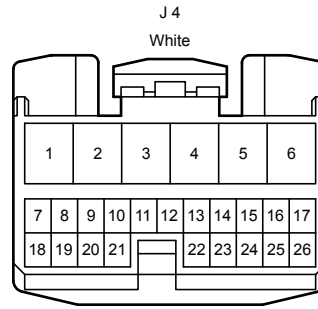
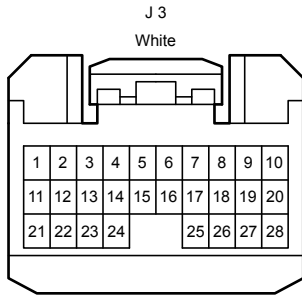
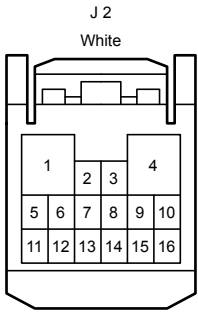

Cargo Light

DC  
White

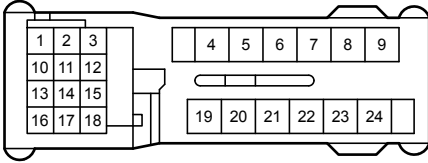

DD  
White

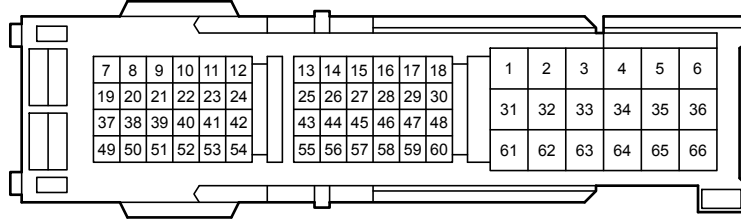

JQ1  
Gray

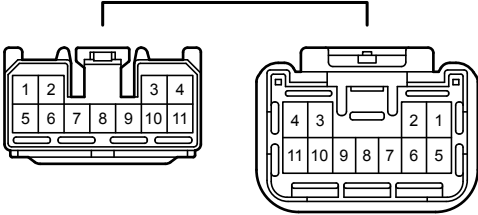

JQ2  
Gray

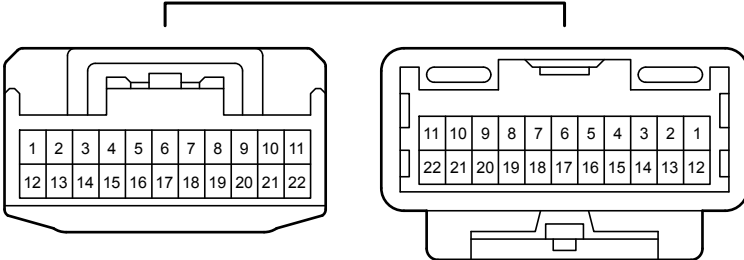

MJ1  
Blue

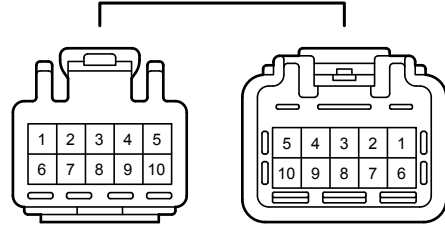

MJ3  
Blue

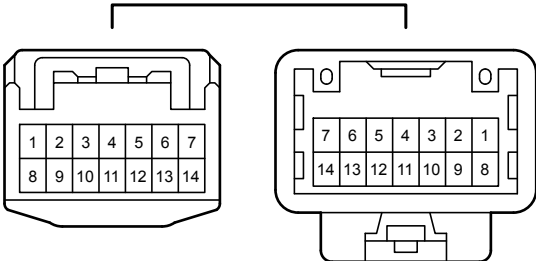

NJ1  
Blue

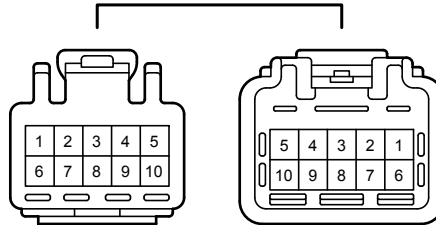

NJ2  
Blue

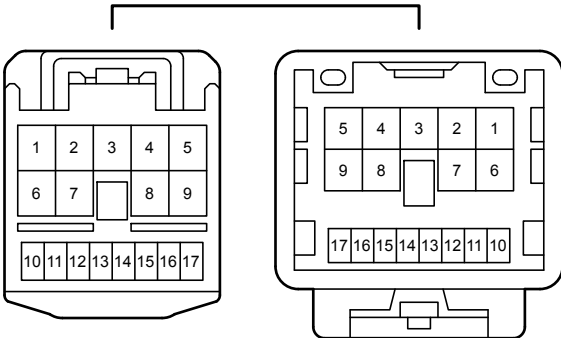

# Cargo Light

OP1  
White

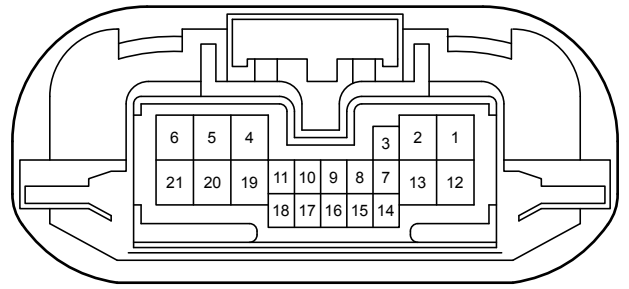
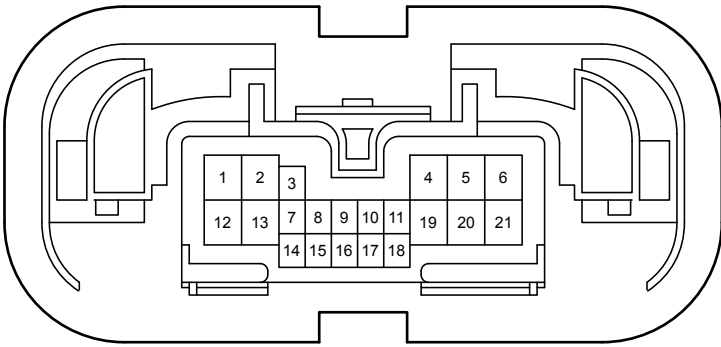

OQ1  
White

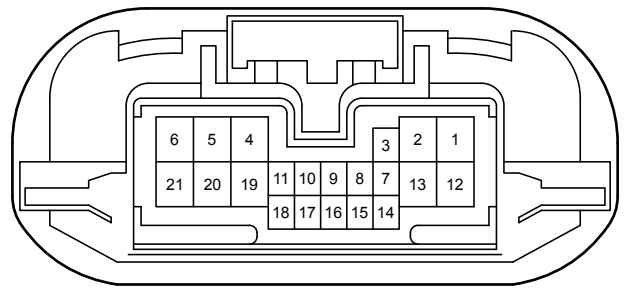
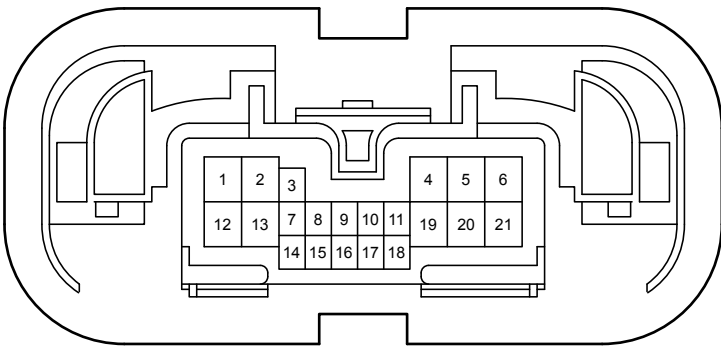

PJ1  
Black

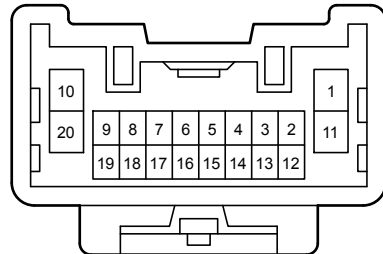
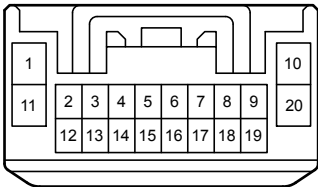



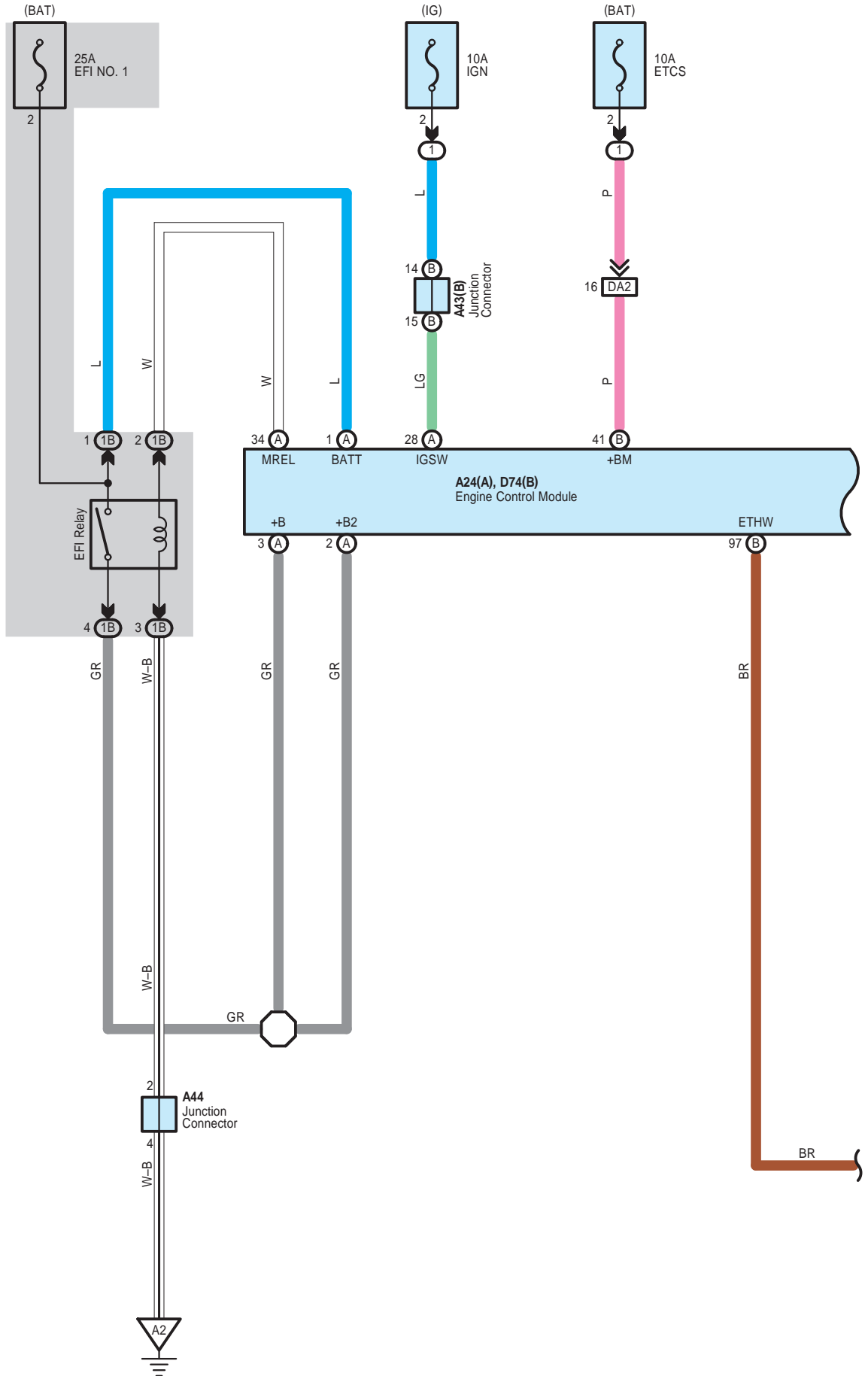

\* 1 : Shielded

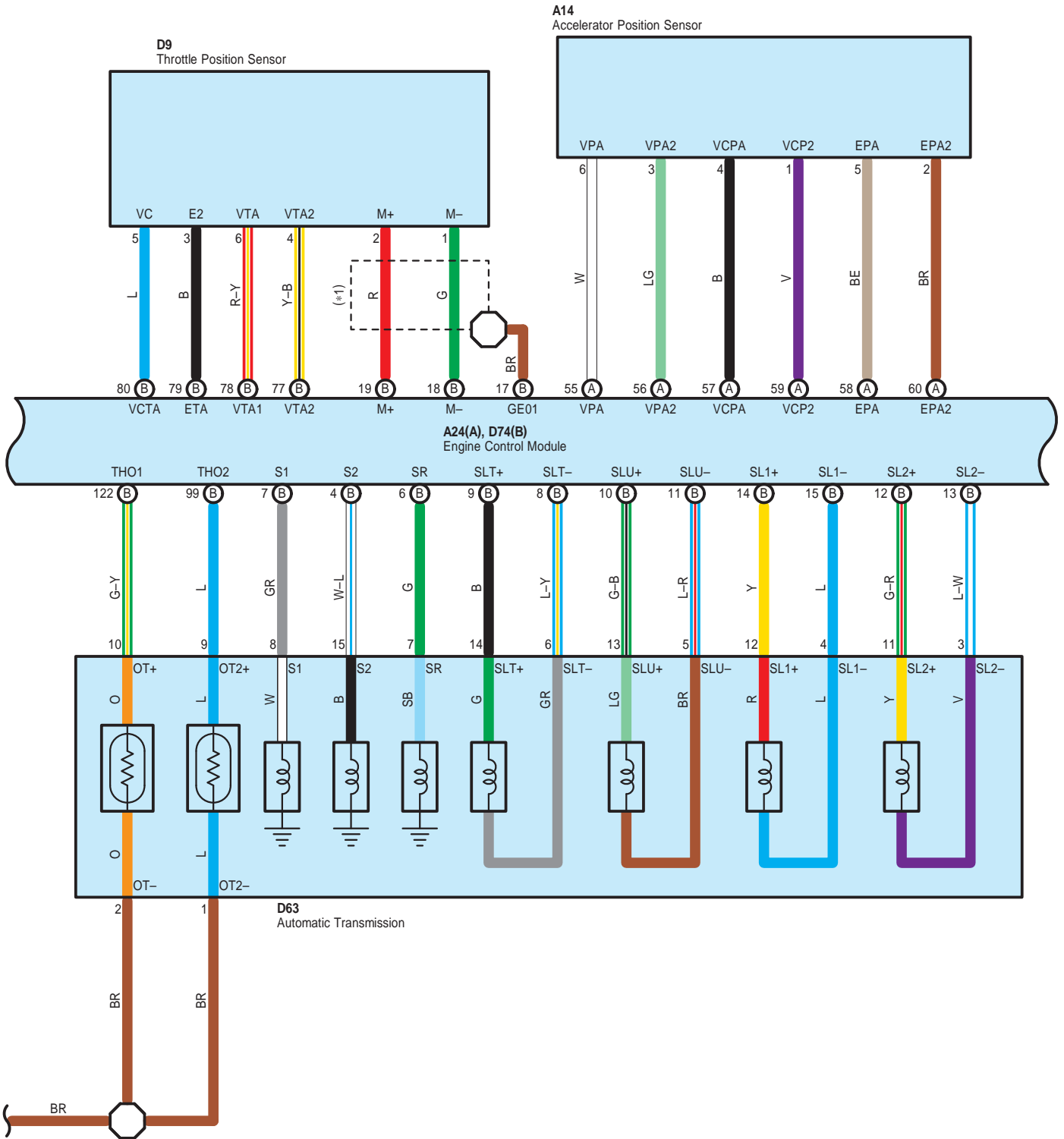

Cruise Control <1GR-FE>

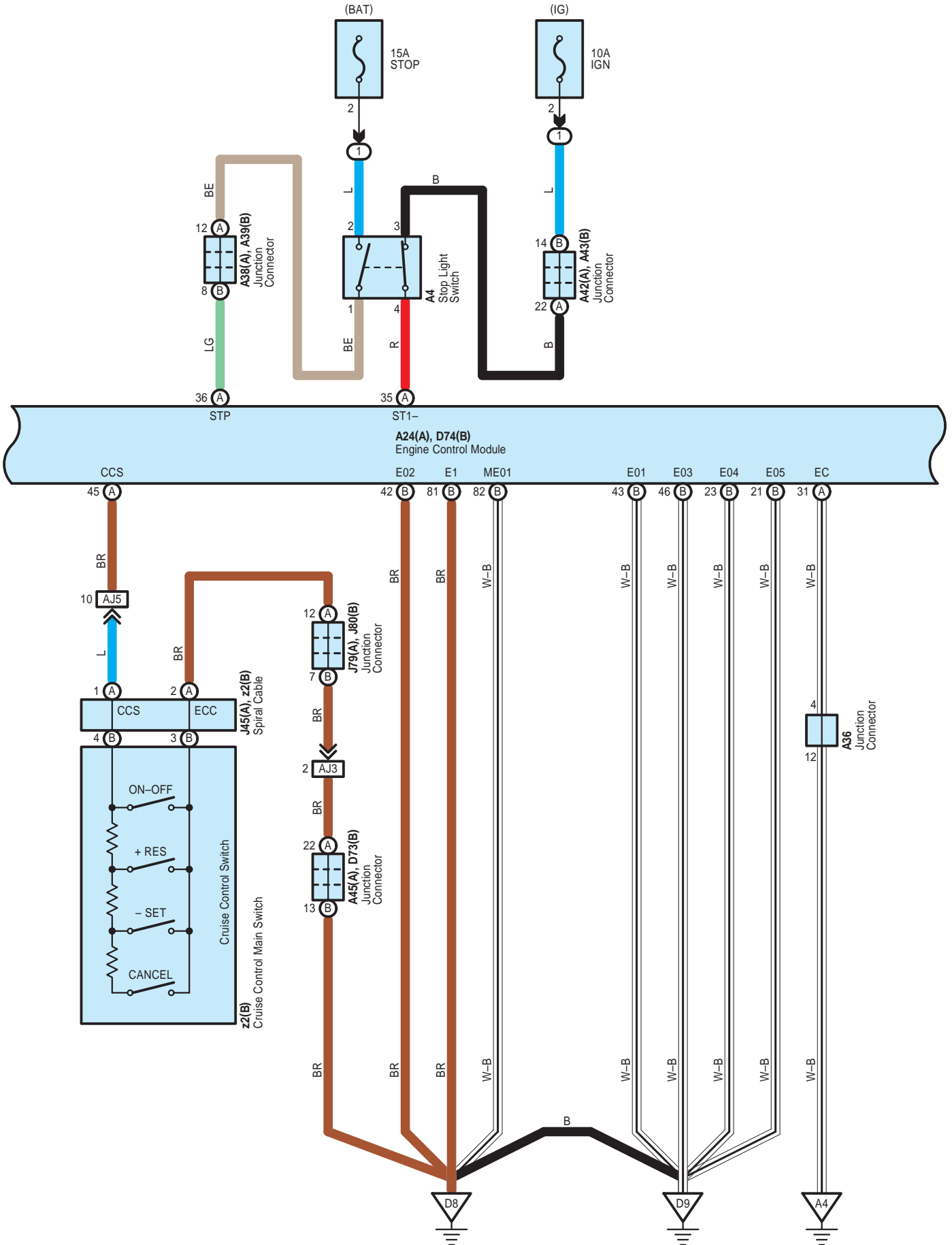

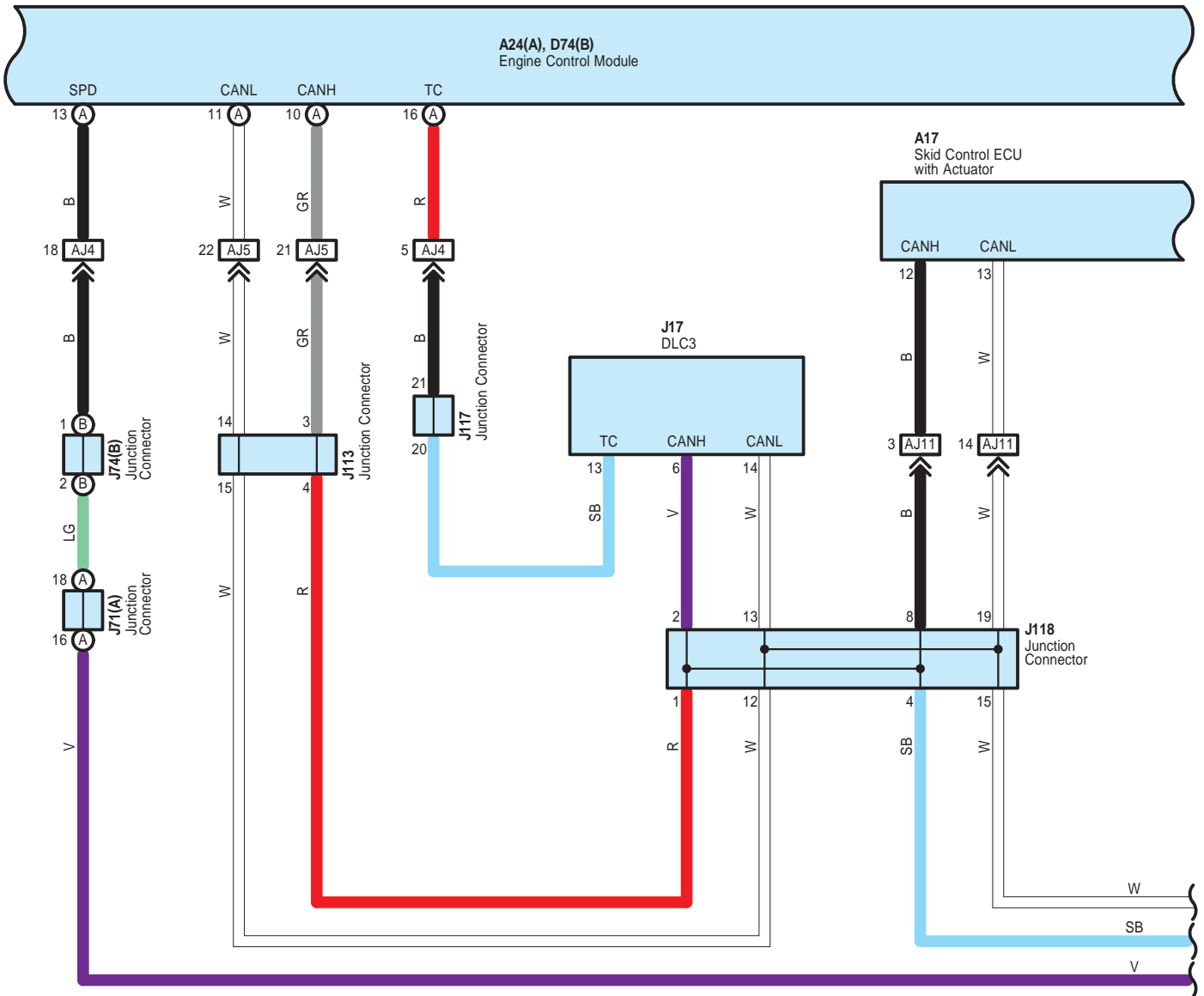

\* 2 : Floor Shift  
 \* 3 : Column Shift

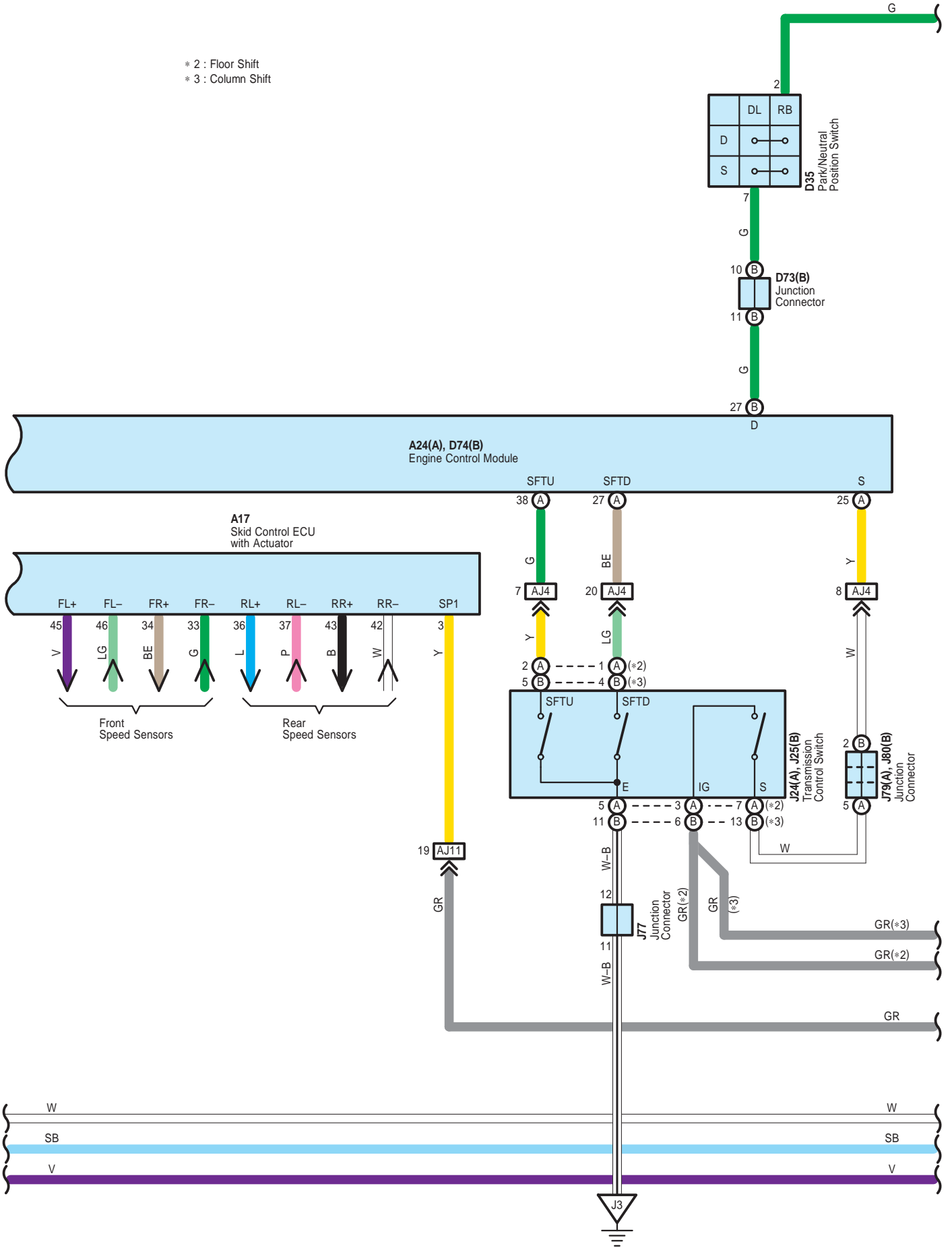

Cruise Control <1GR-FE>

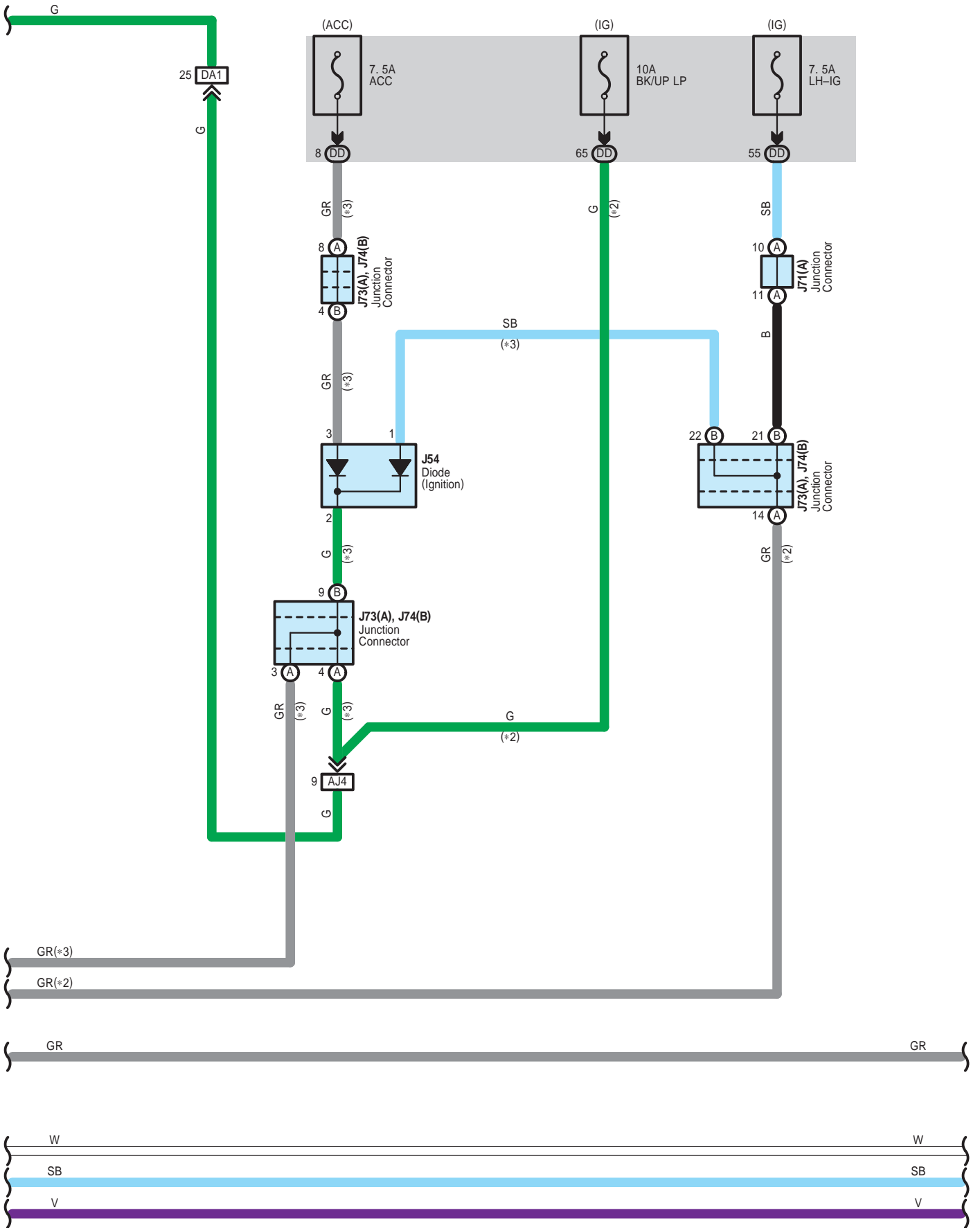

Cruise Control <1GR-FE>

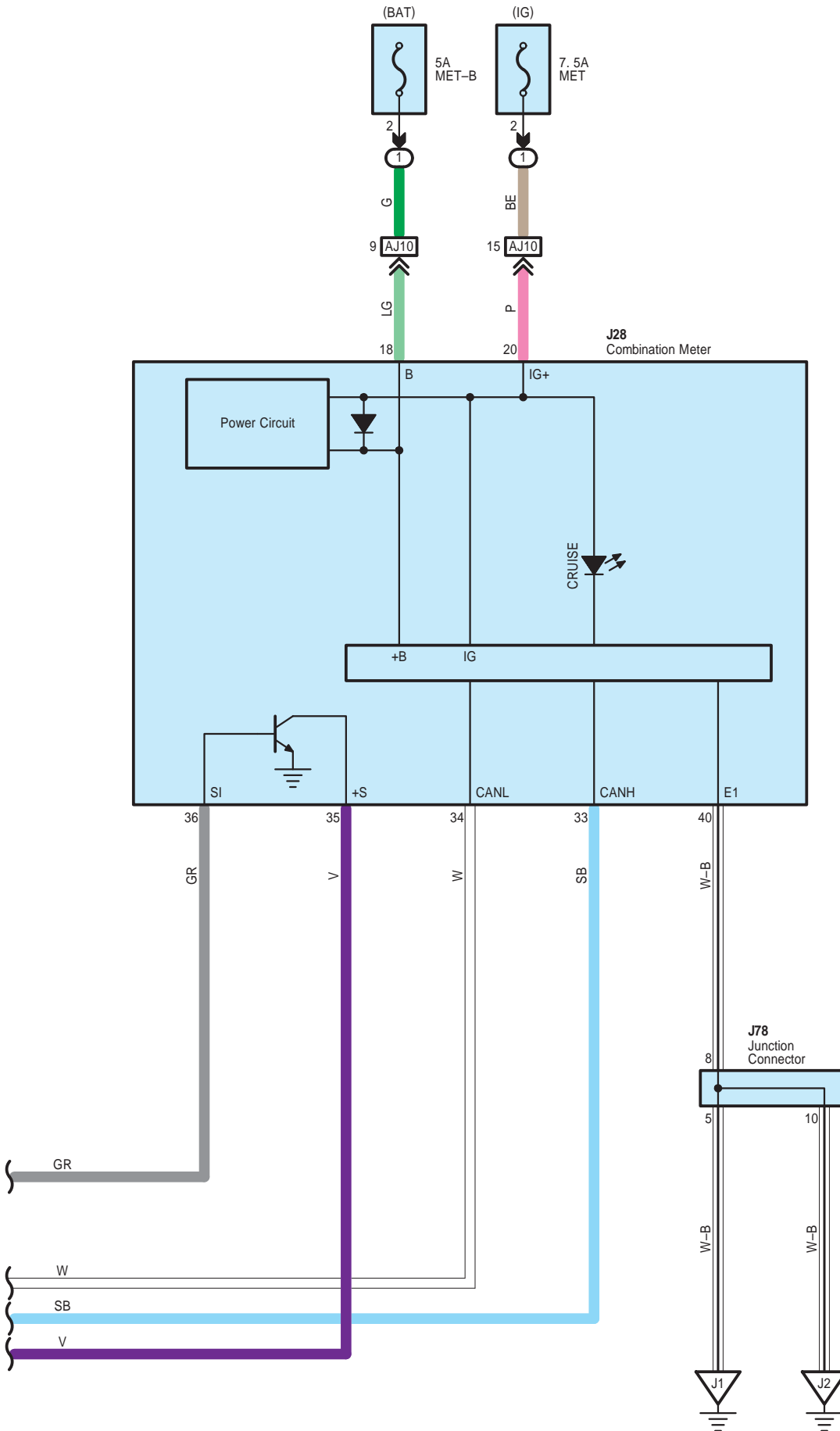

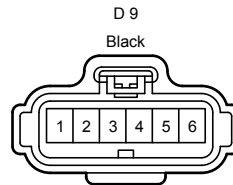
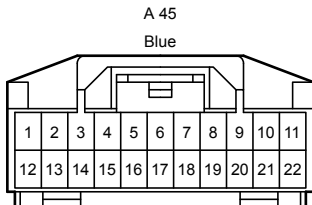
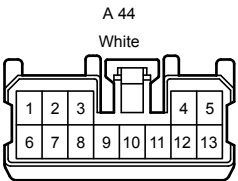
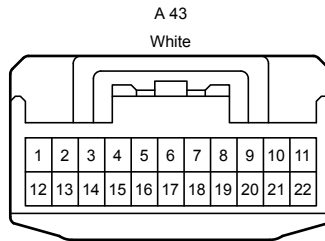
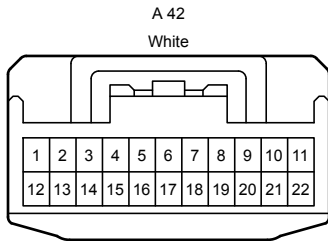
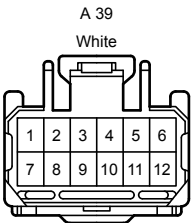
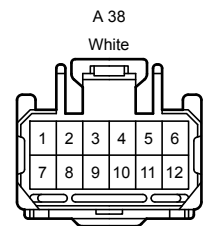
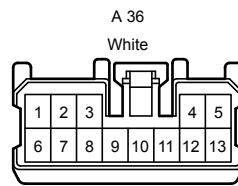
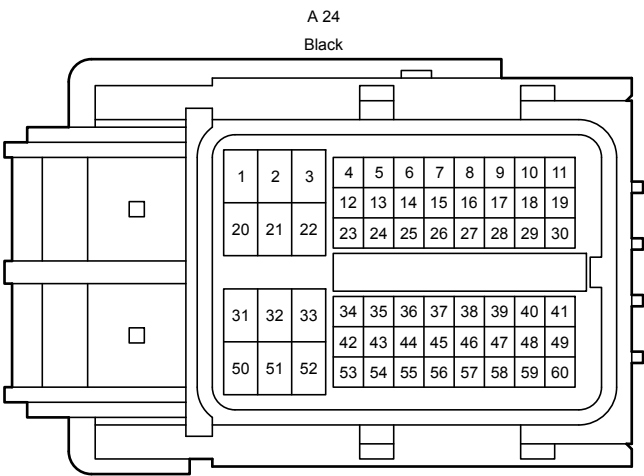
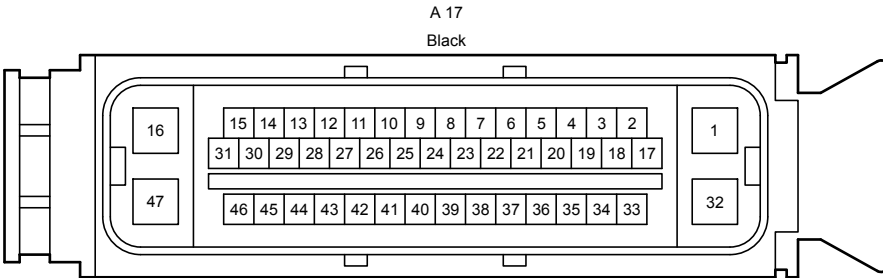
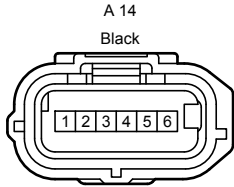
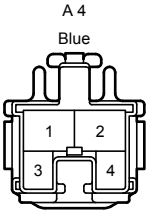



Cruise Control <1GR-FE>

D 35  
Gray

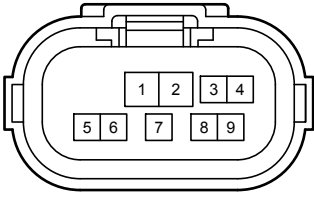

D 63  
Gray

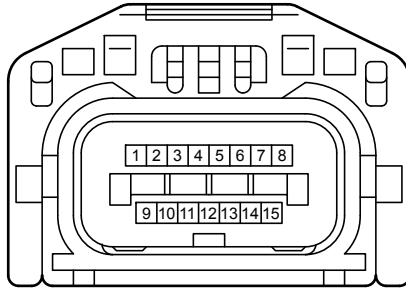

D 73  
Blue

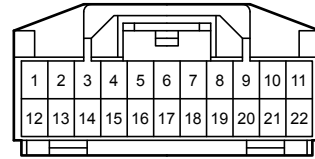

D 74  
Black

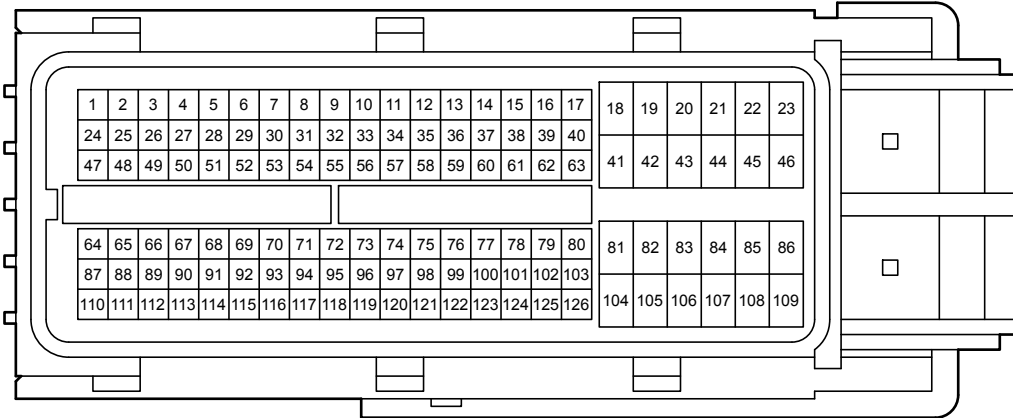

J 17  
White

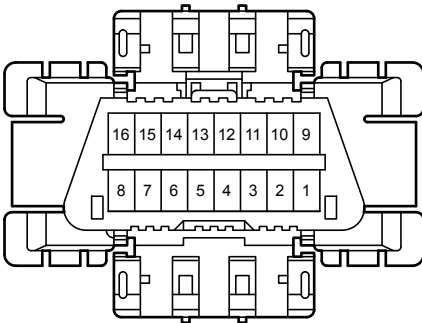

J 24  
White

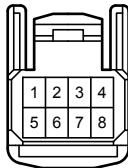

J 25  
White

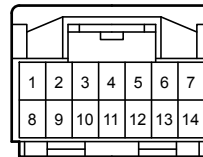

J 28  
White

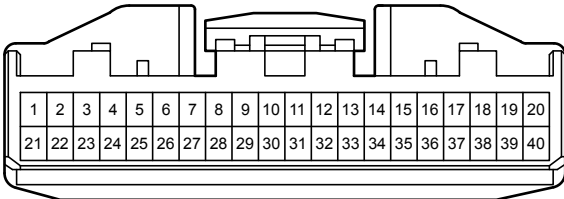

J 45  
Black

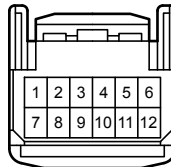

J 54  
Orange

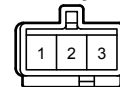

J 71  
Black

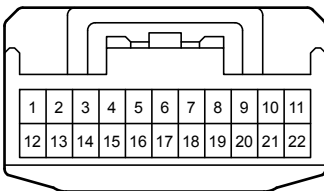

J 73  
Black

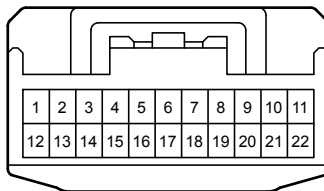

J 74  
Black

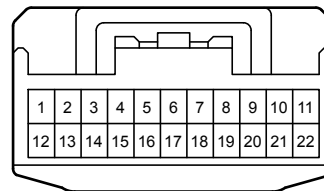

Cruise Control <1GR-FE>

J 77

Gray

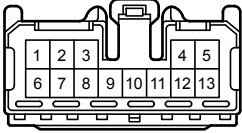

J 78

White

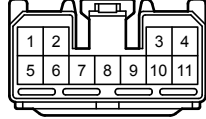

J 79

White

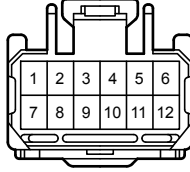

J 80

White

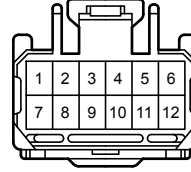

J113

Gray

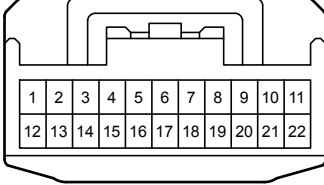

J117

Black

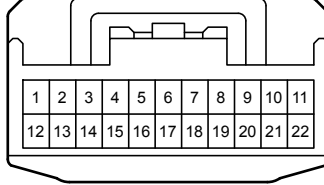

J118

Gray

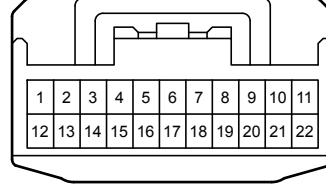

z 2

Black

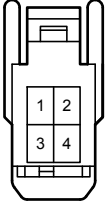

1B

White

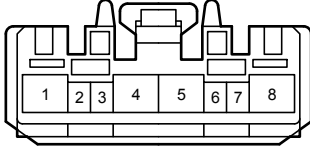

DD

White

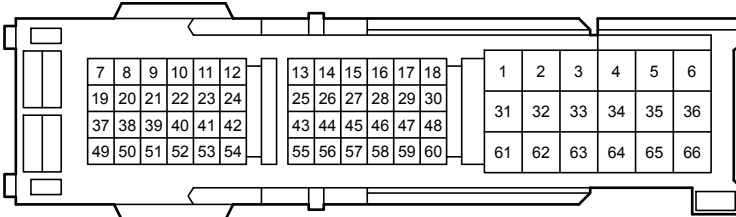

AJ3

White

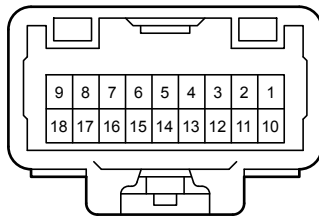
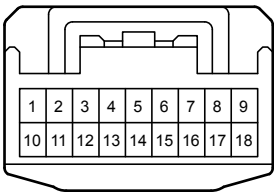

AJ4

White

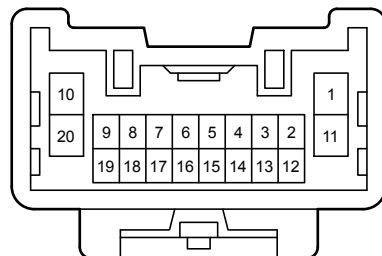
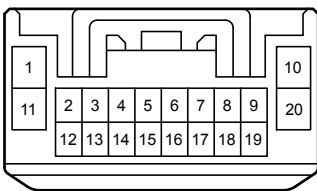

AJ5  
White

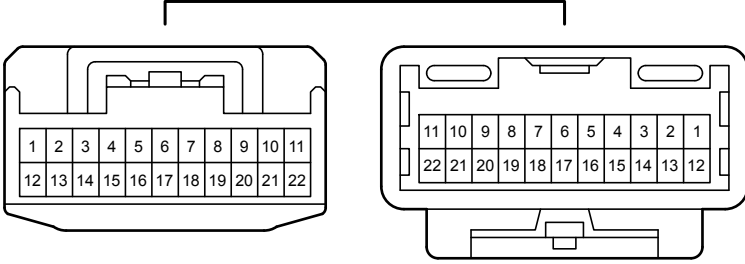

AJ10  
Gray

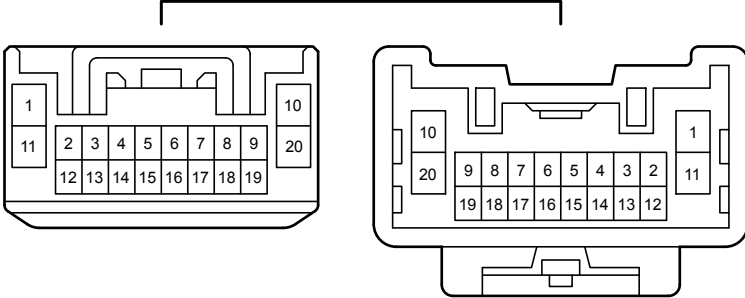

AJ11  
Gray

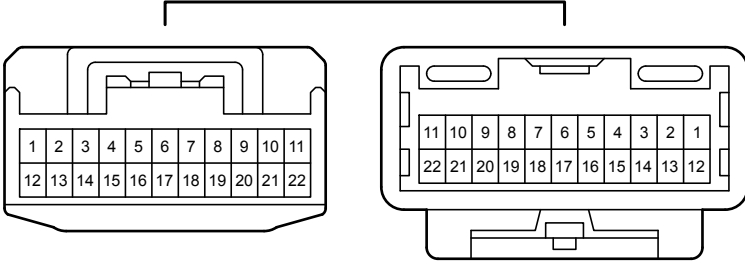

DA1  
White

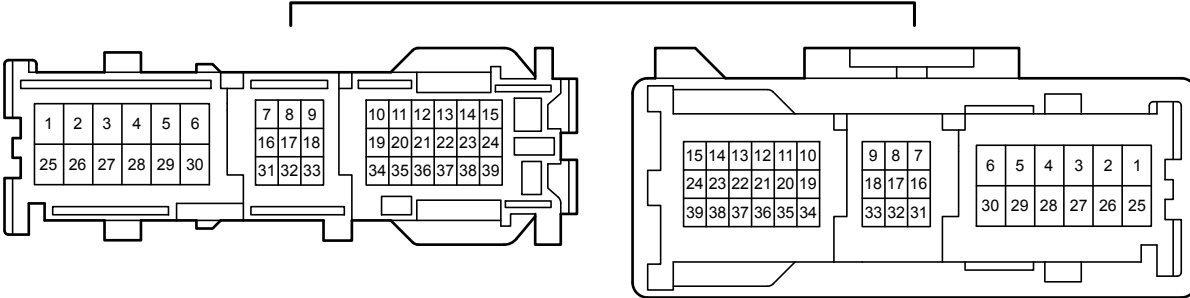

DA2  
White

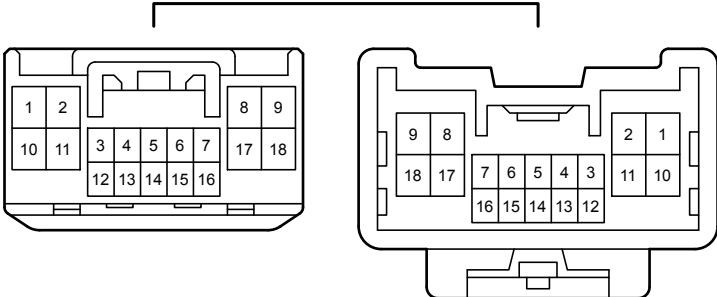

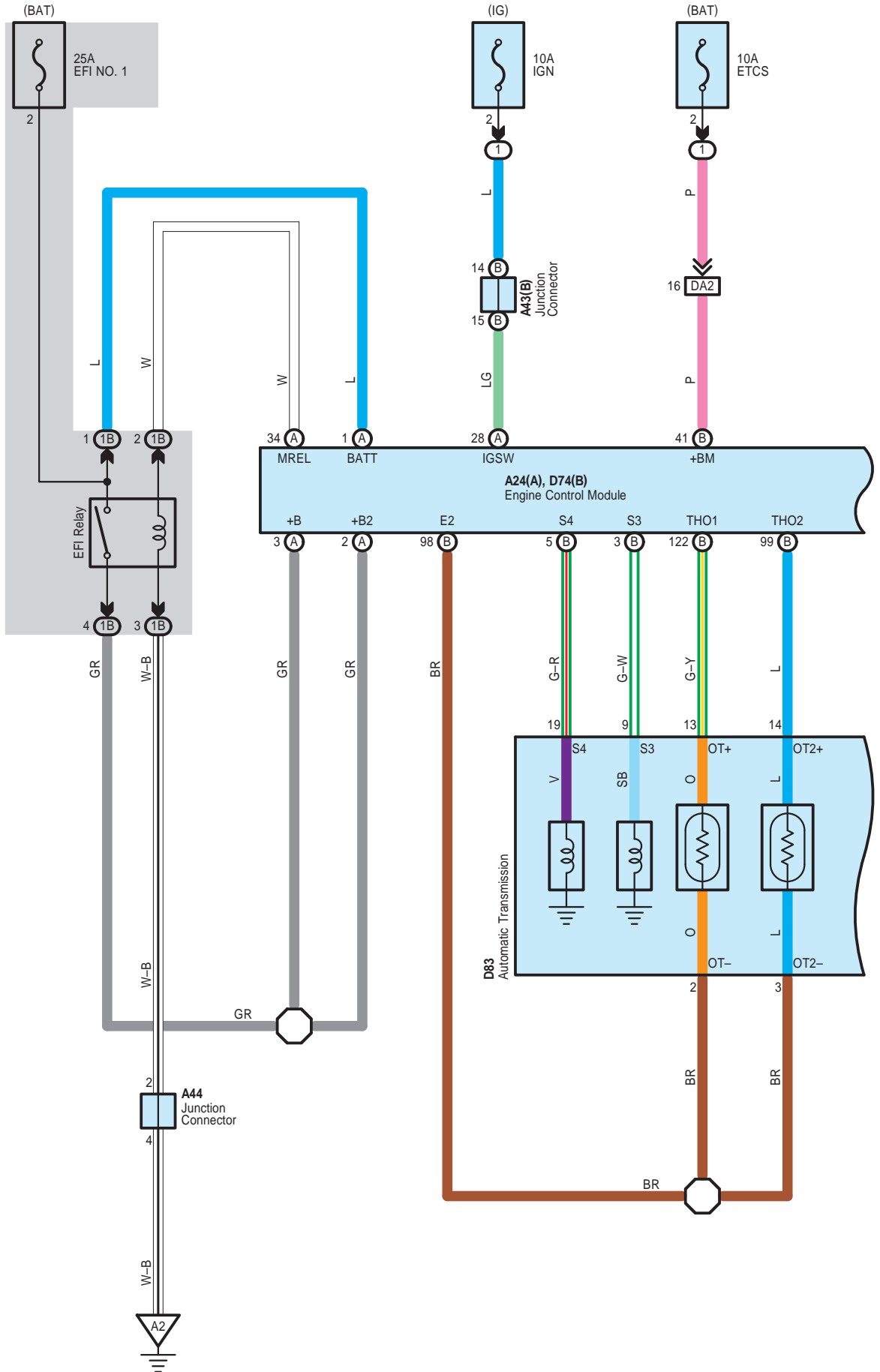

\* 1 : Shielded

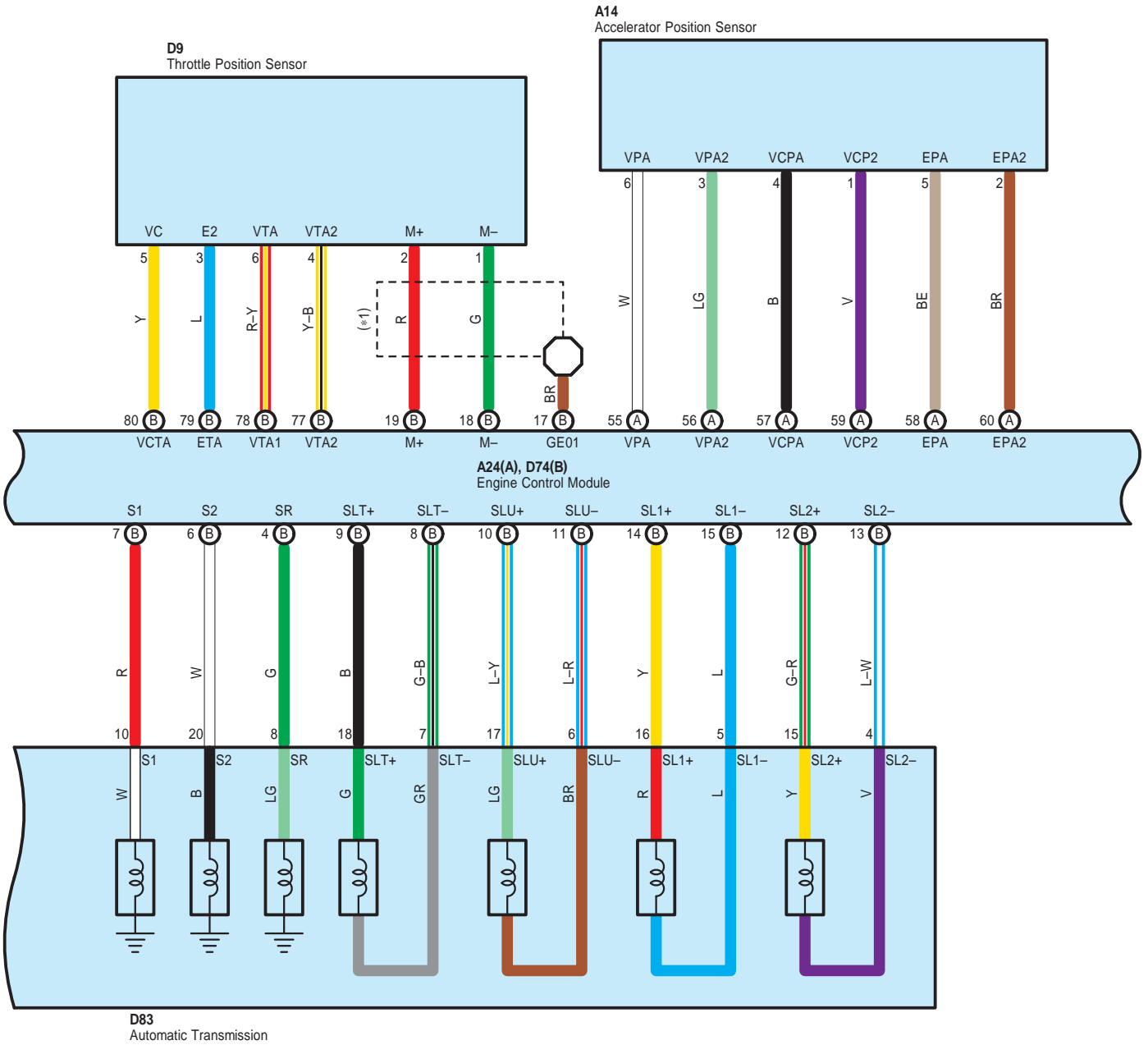

Cruise Control <1UR-FE>

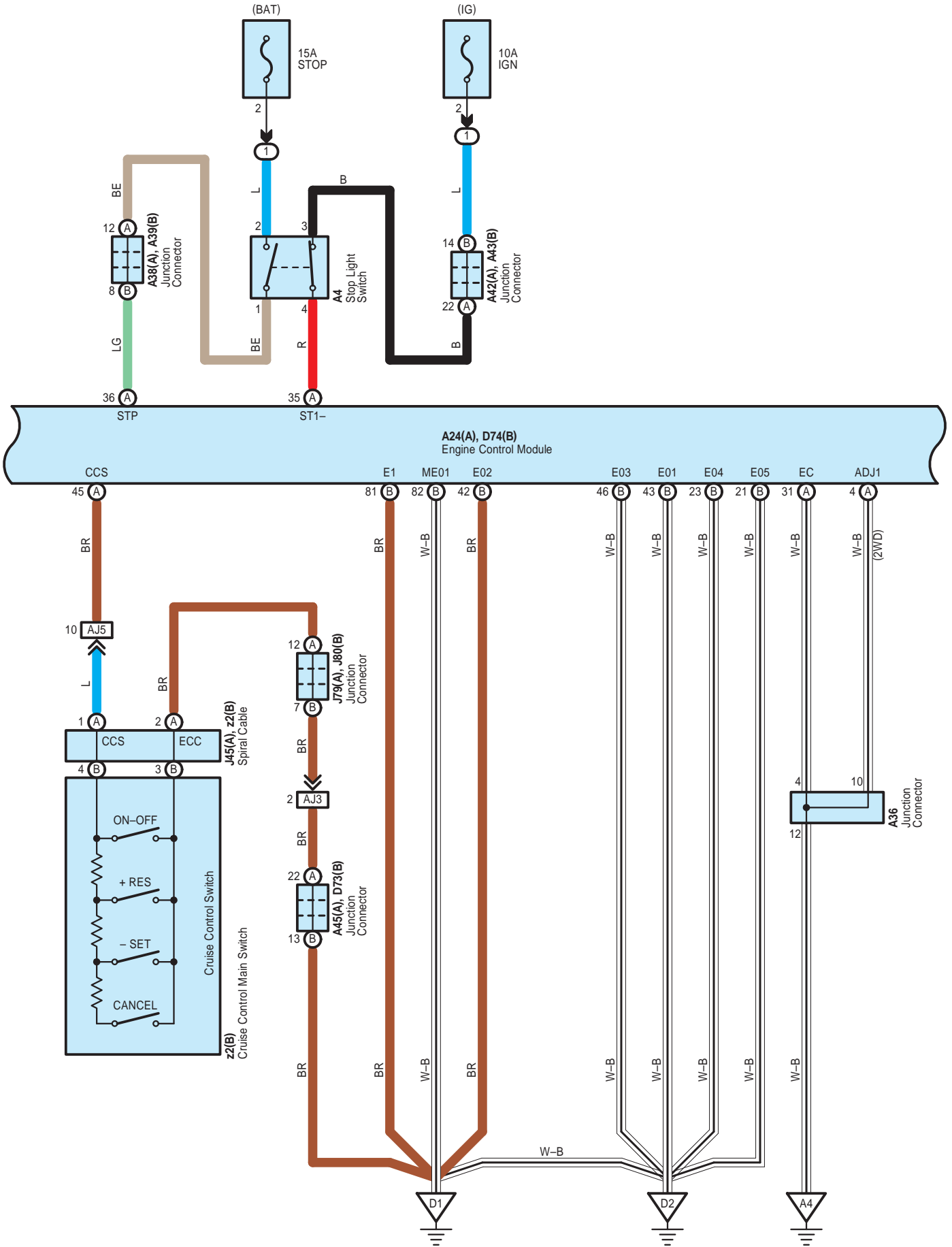

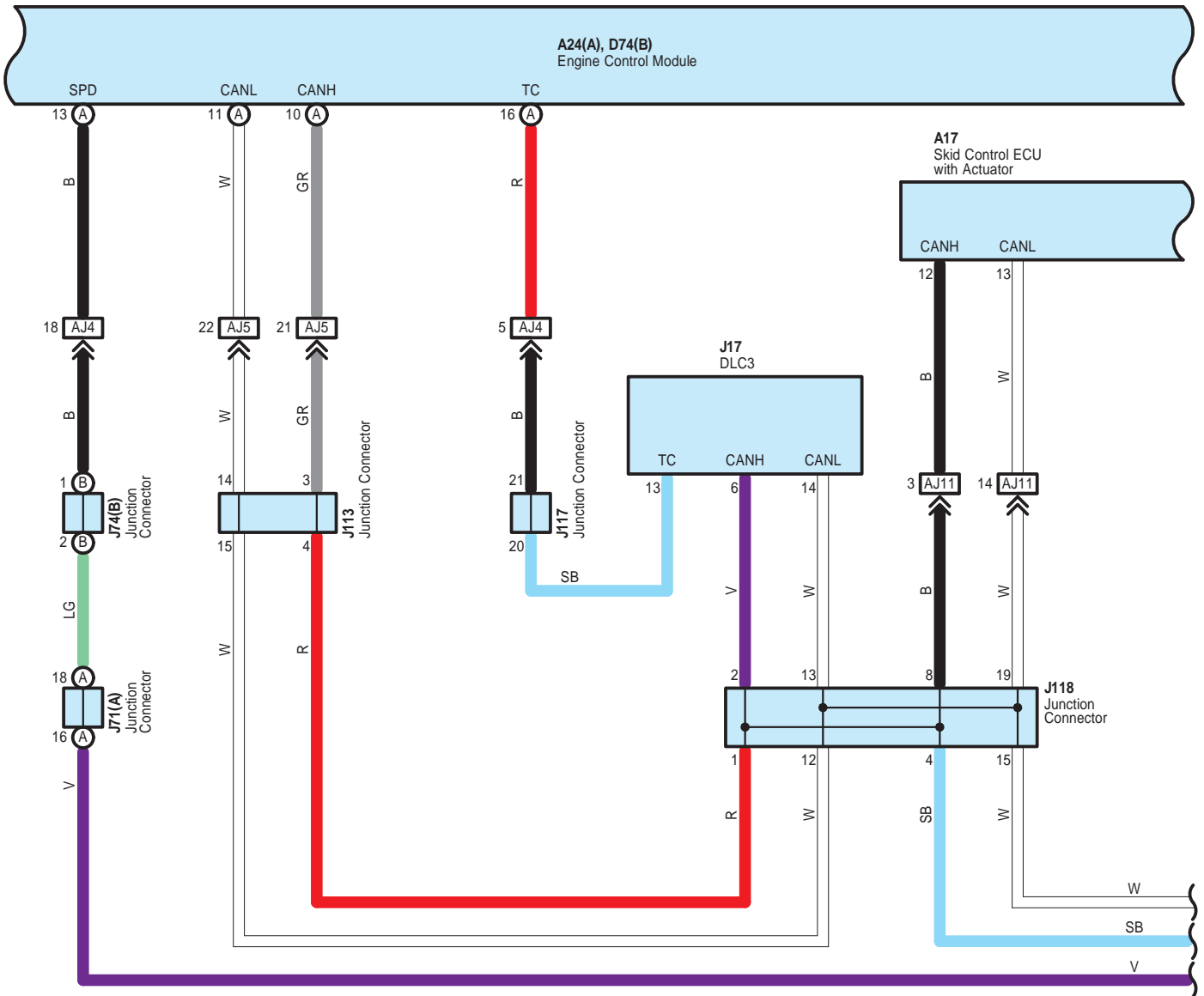

- \* 2 : Floor Shift
- \* 3 : Column Shift

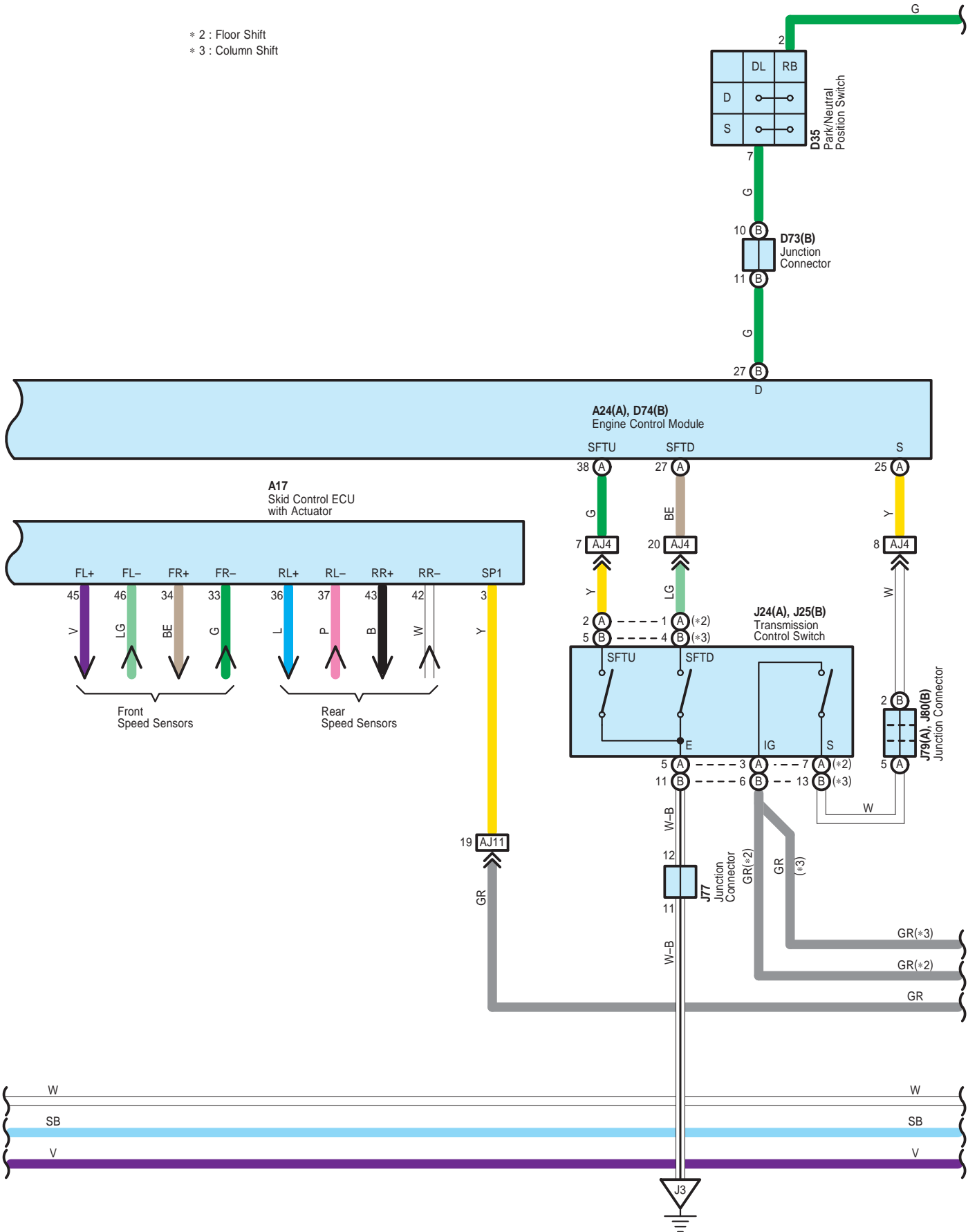





Cruise Control <1UR-FE>

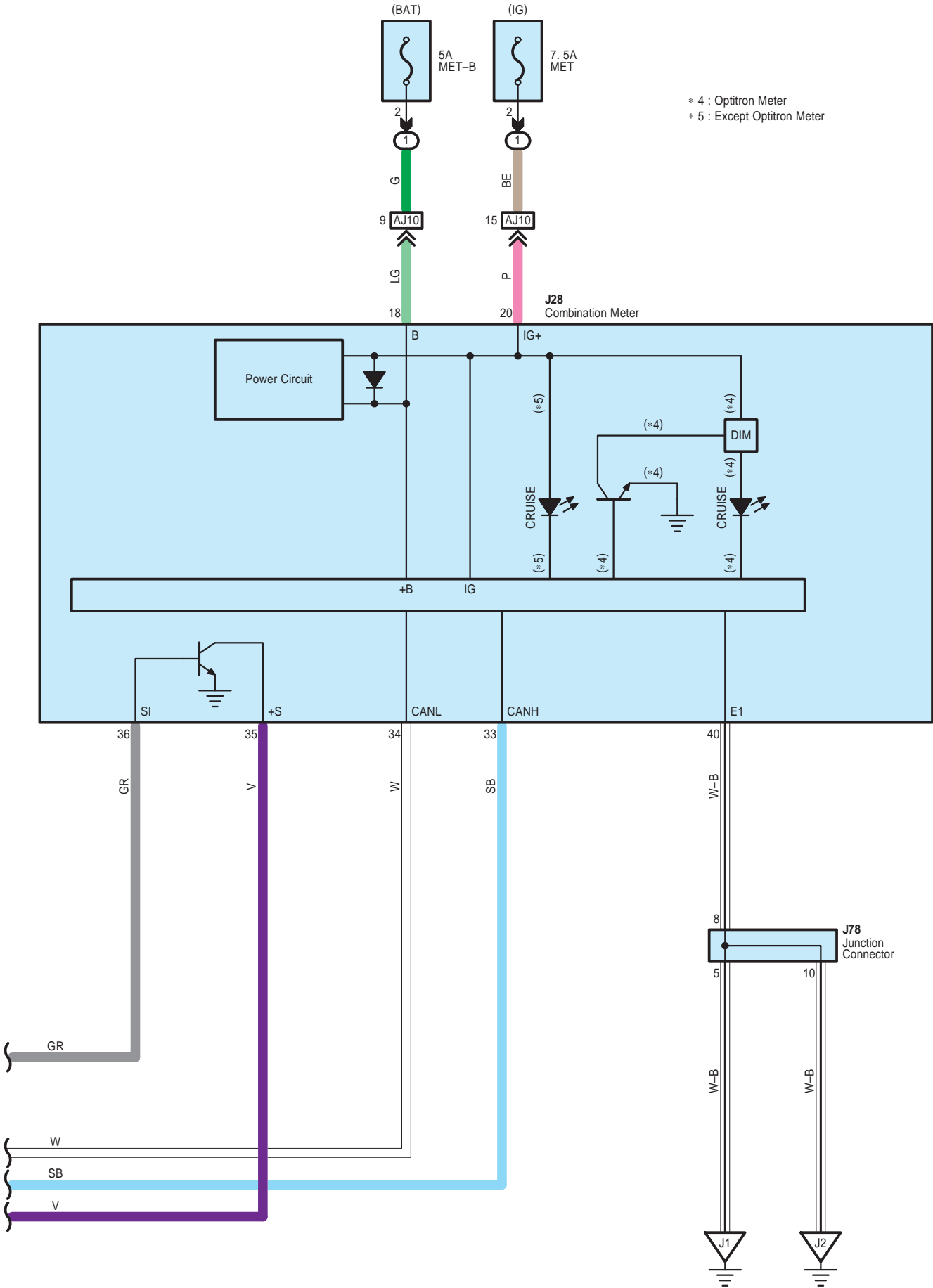

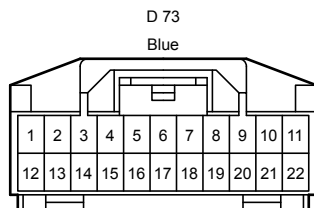
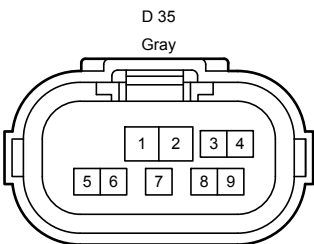
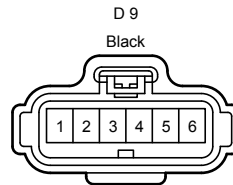
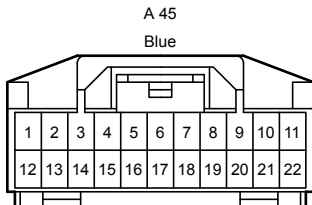
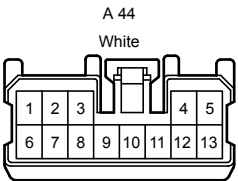
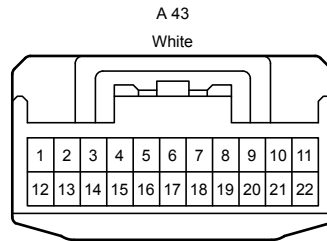
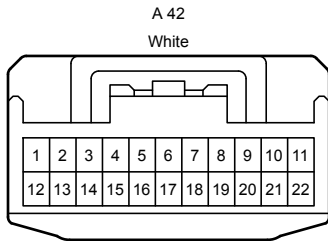
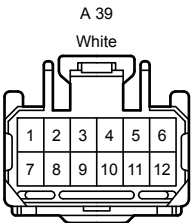
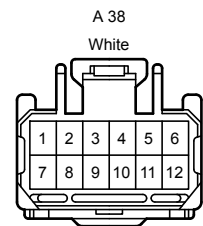
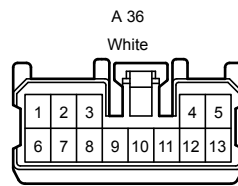
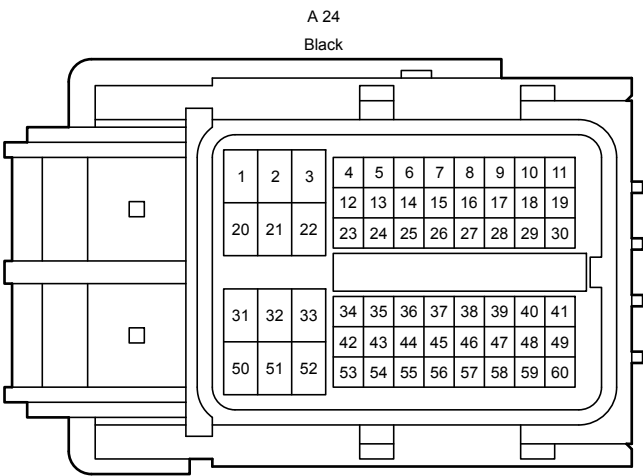
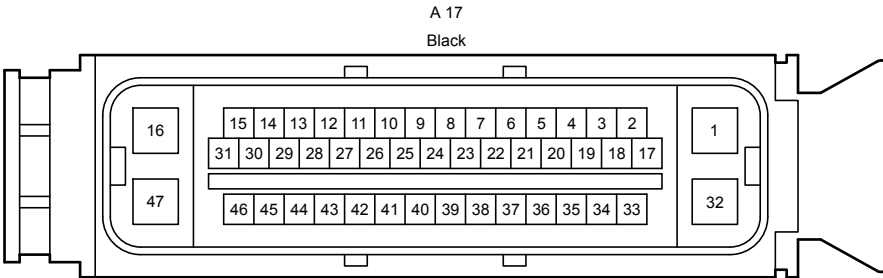
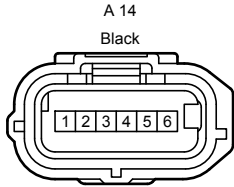
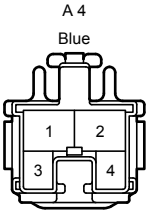

Cruise Control <1UR-FE>

D 74  
Black

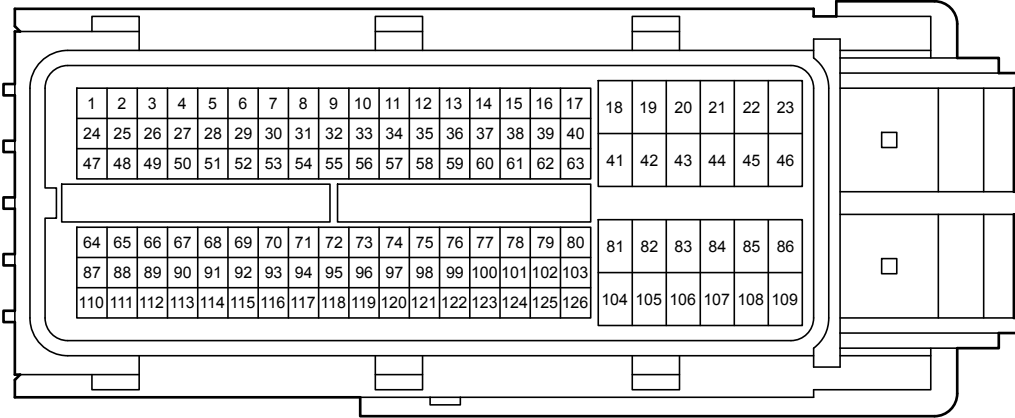

D 83  
Gray

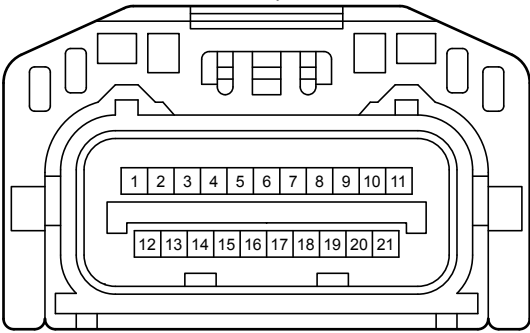

J 17  
White

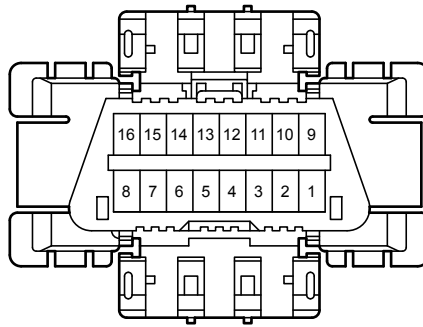

J 24  
White

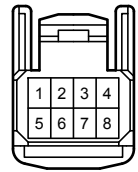

J 25  
White

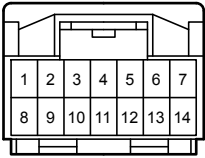

J 28  
White

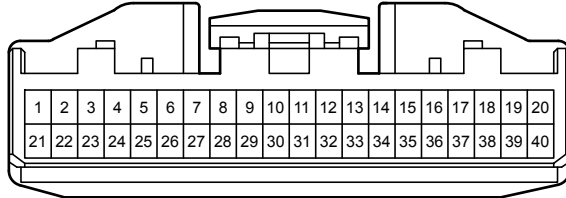

J 45  
Black

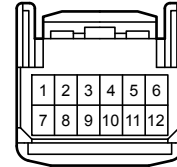

J 54  
Orange

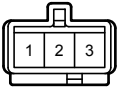

J 71  
Black

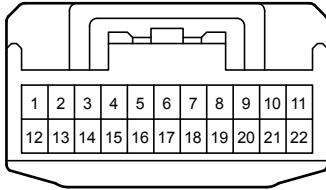

J 73  
Black

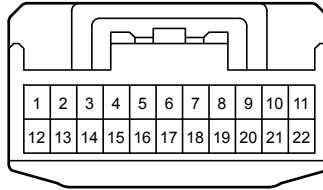

J 74  
Black

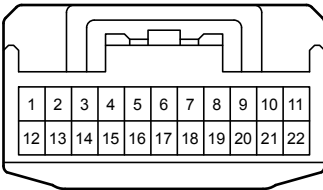

J 77  
Gray

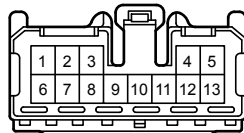

J 78  
White

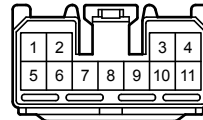

J 79  
White

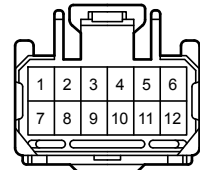

Cruise Control <1UR-FE>

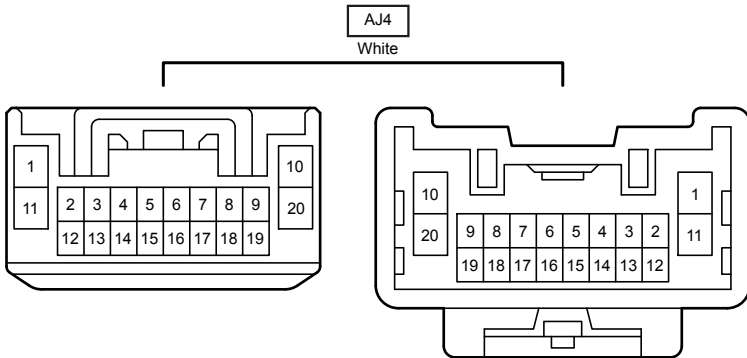
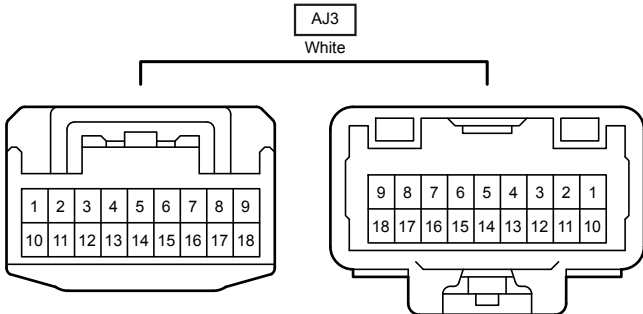
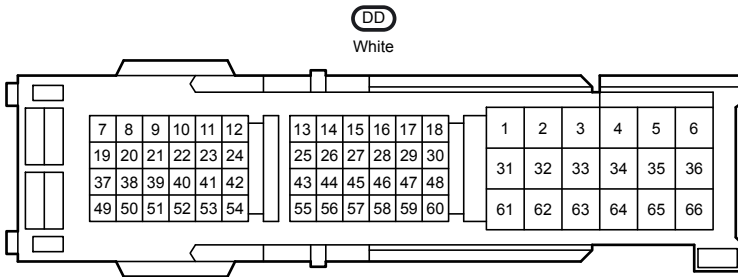
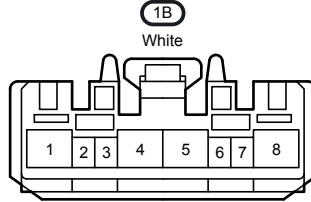
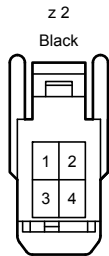
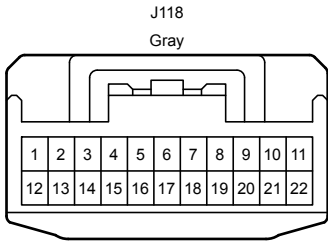
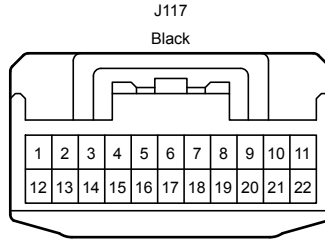
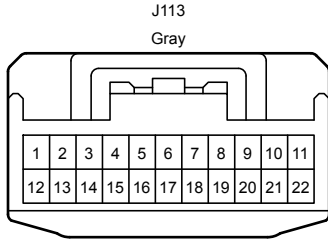
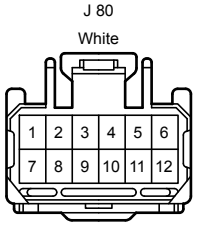

AJ5  
White

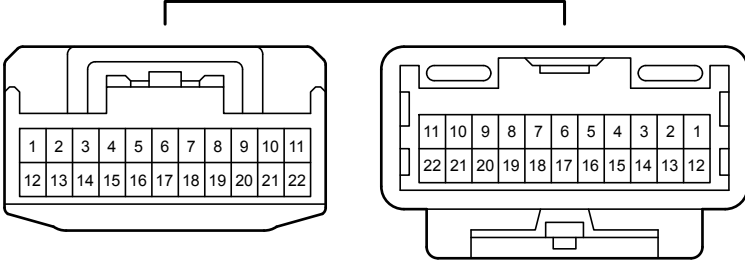

AJ10  
Gray

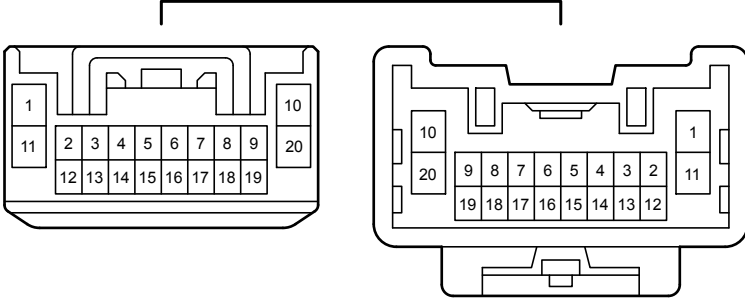

AJ11  
Gray

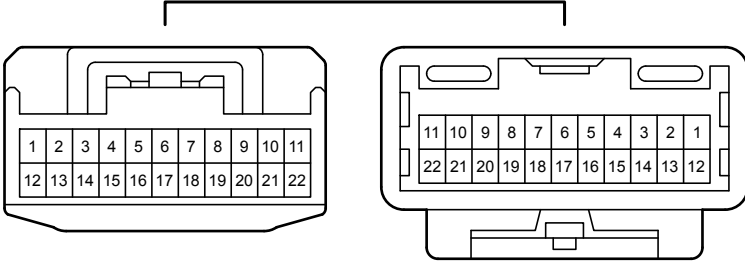

DA1  
White

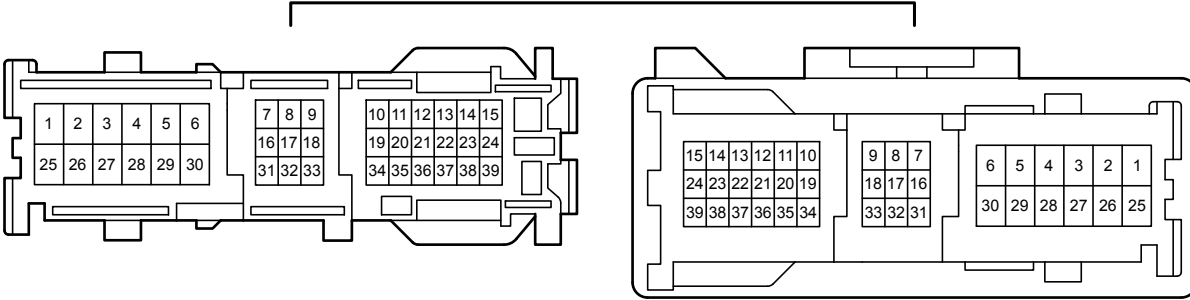

DA2  
White

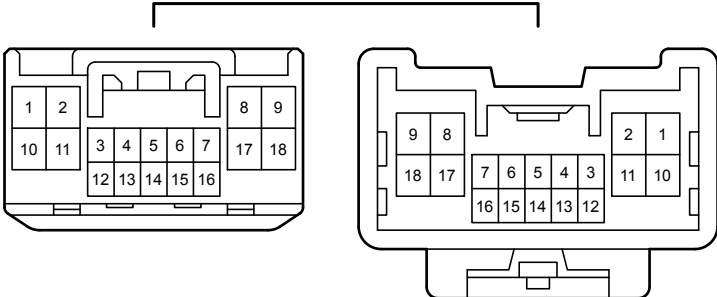



\* 1 : Shielded

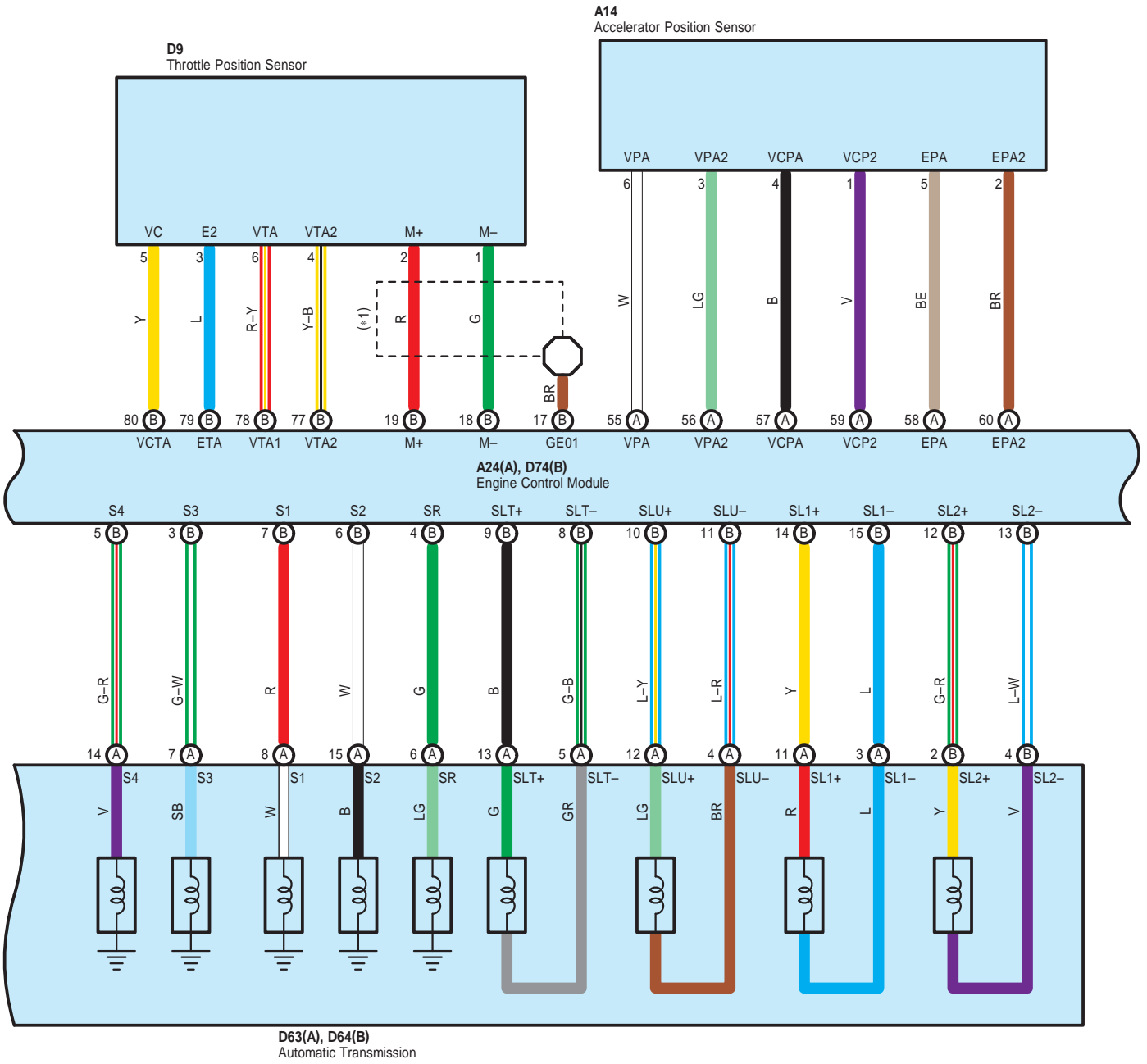



Cruise Control <3UR-FE, 3UR-FBE>

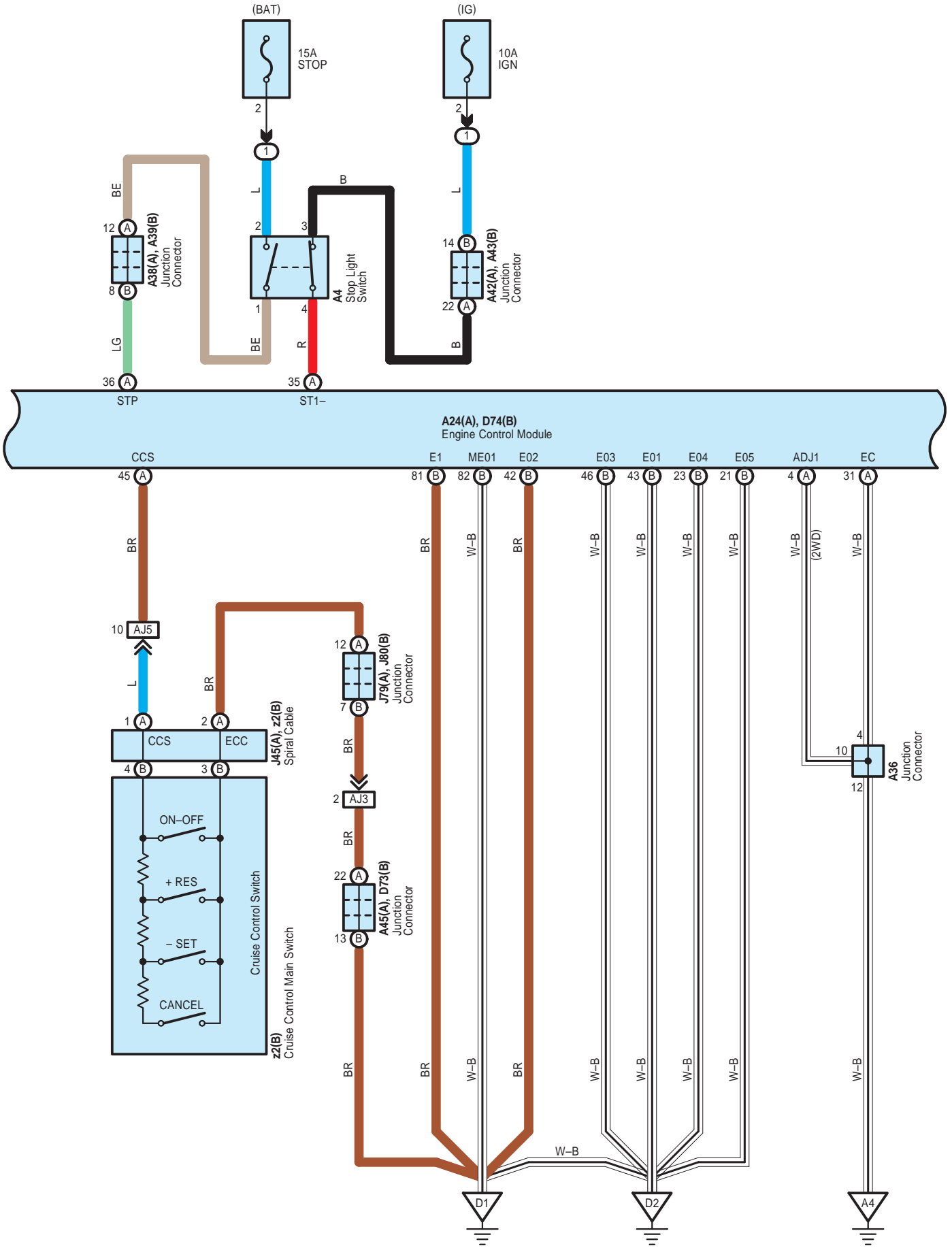



\* 2 : Floor Shift  
 \* 3 : Column Shift

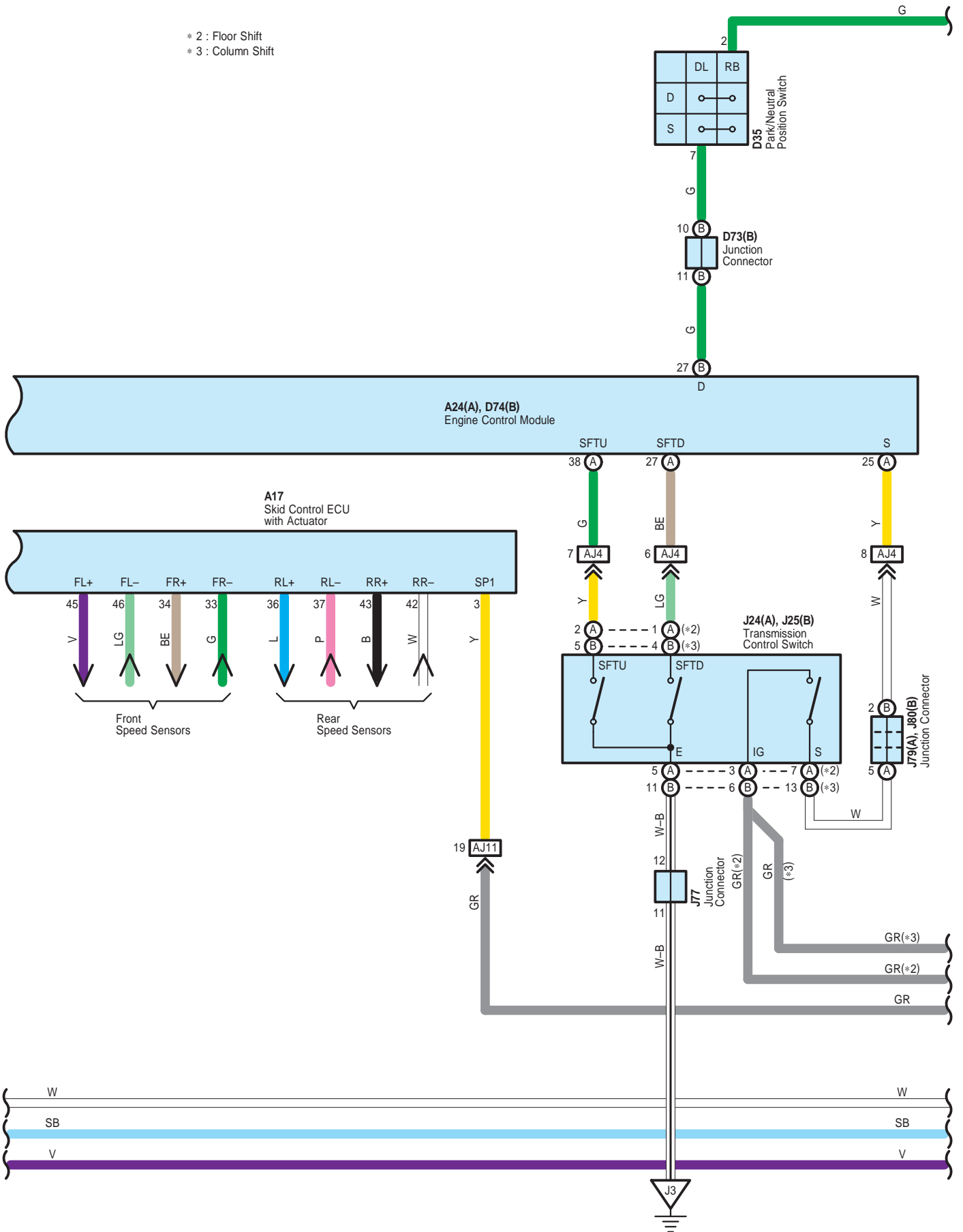

Cruise Control <3UR-FE, 3UR-FBE>

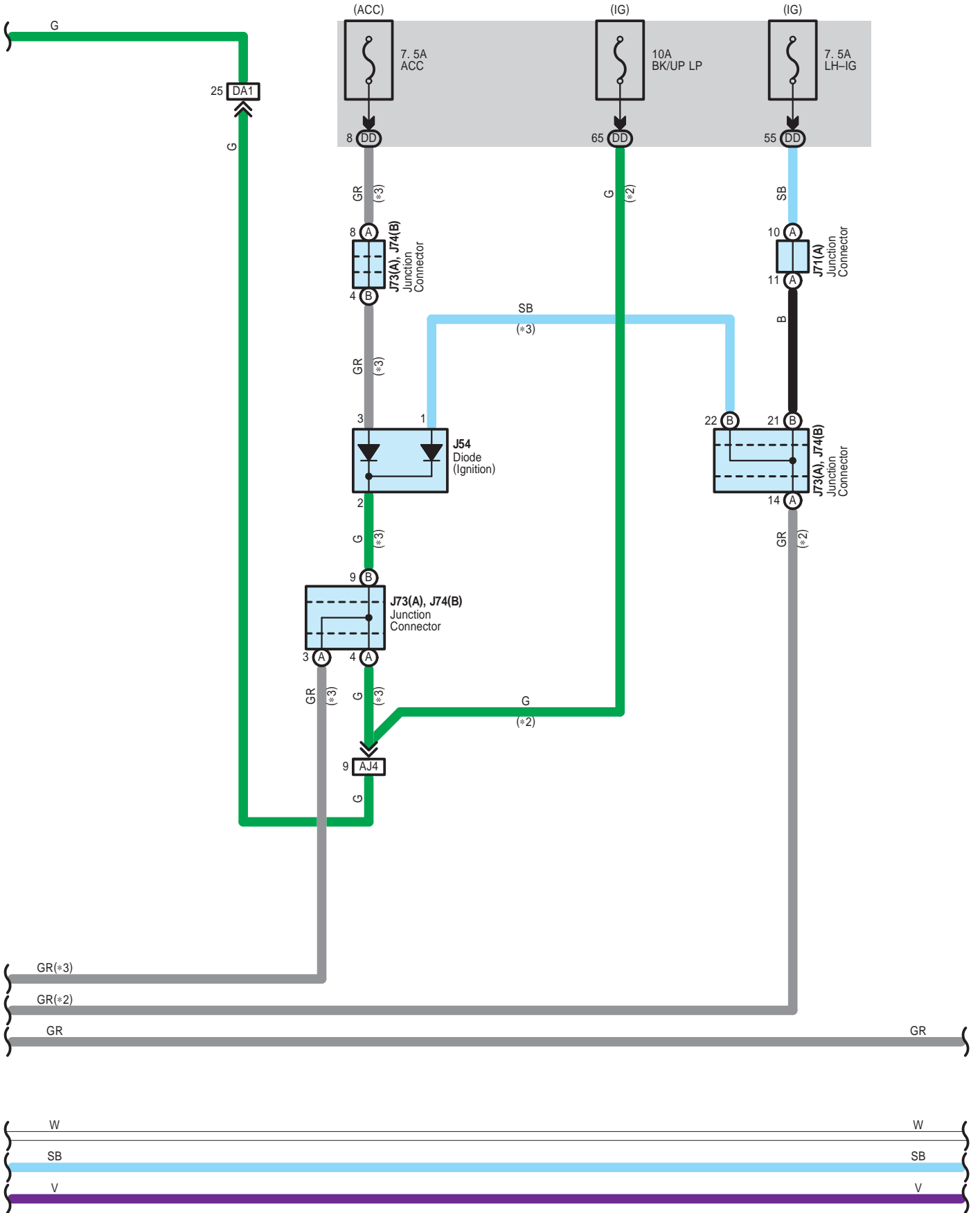

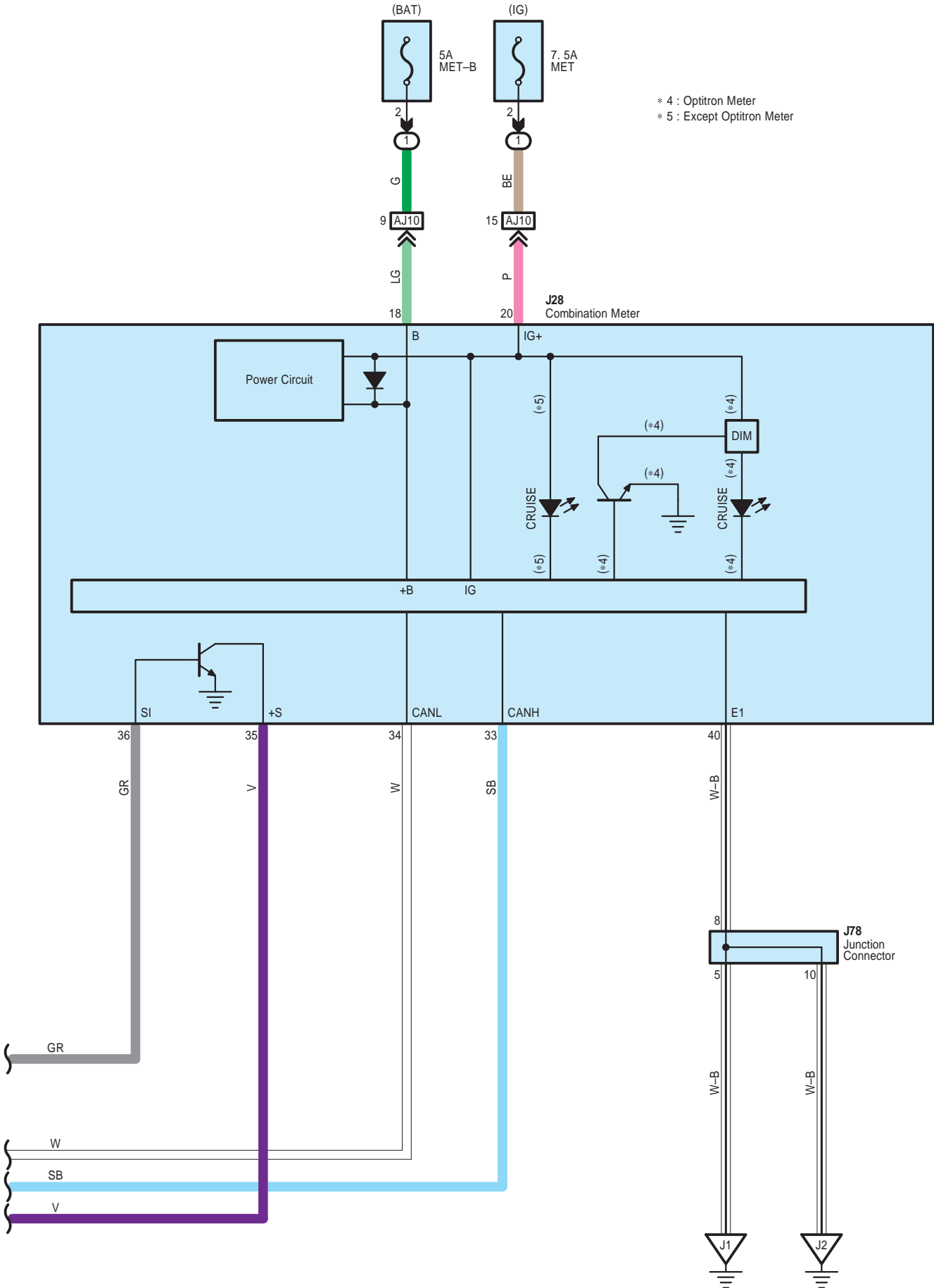

Cruise Control <3UR-FE, 3UR-FBE>

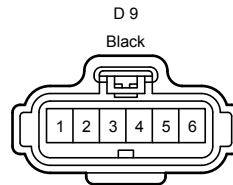
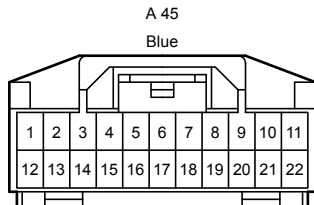
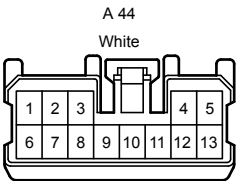
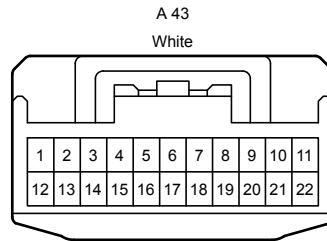
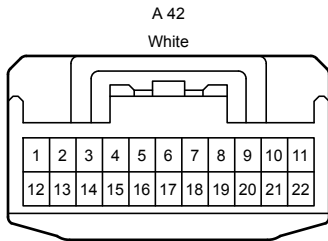
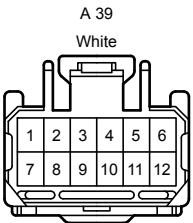
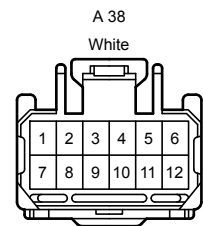
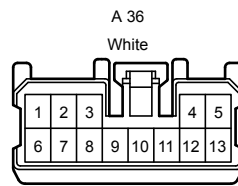
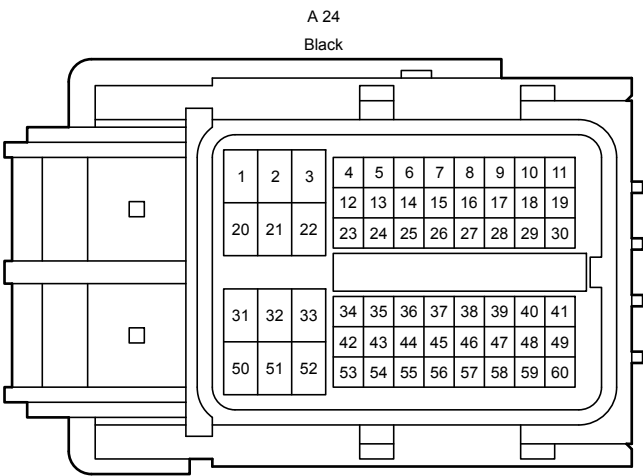
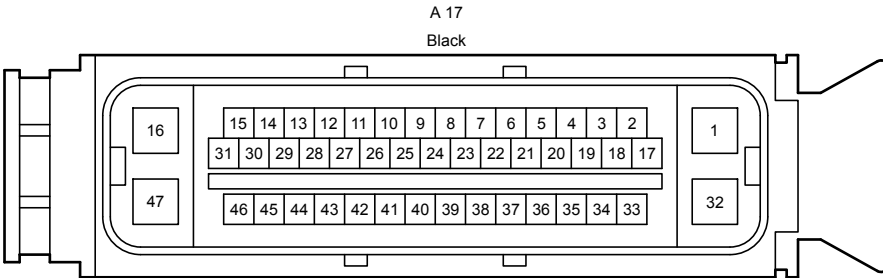
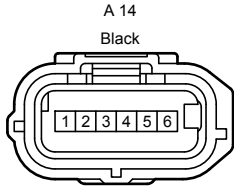
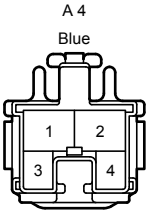

Cruise Control <3UR-FE, 3UR-FBE>

D 35  
Gray

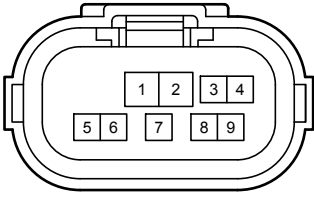

D 63  
Gray

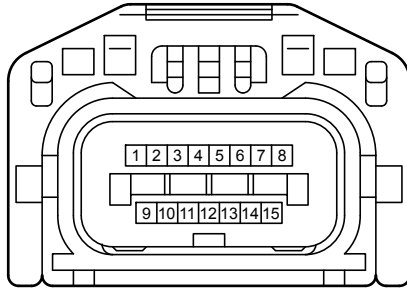

D 64  
Gray

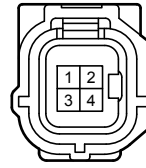

D 73  
Blue

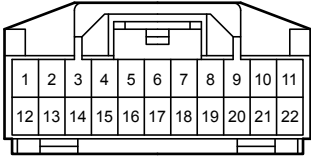

D 74  
Black

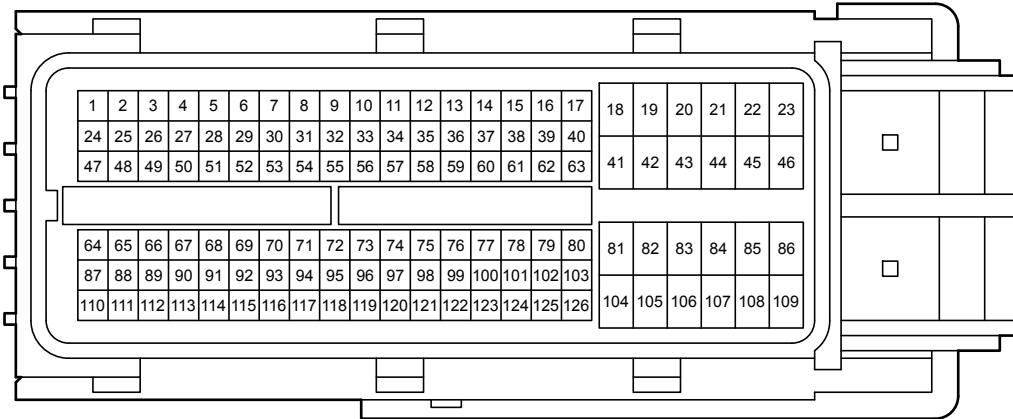

J 17  
White

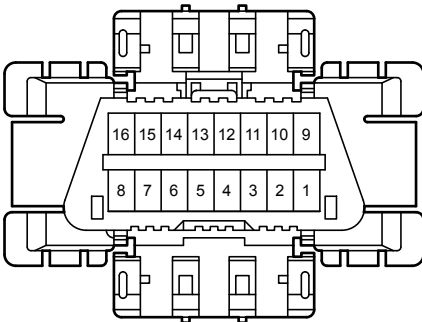

J 24  
White

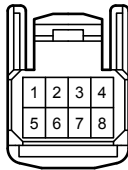

J 25  
White

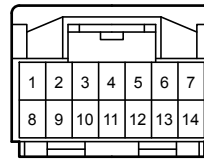

J 28  
White

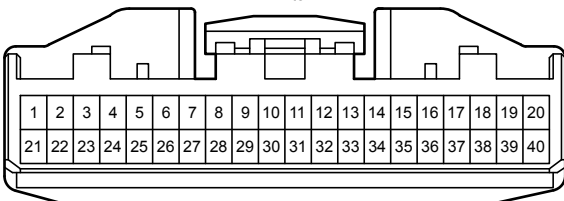

J 45  
Black

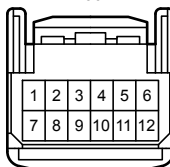

J 54  
Orange

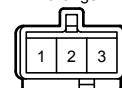

Cruise Control <3UR-FE, 3UR-FBE>

J 71  
Black

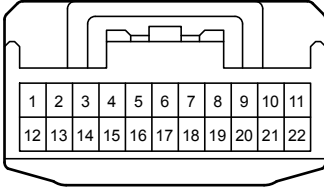

J 73  
Black

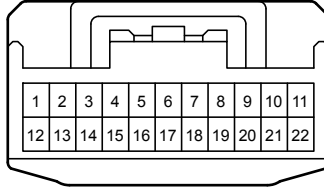

J 74  
Black

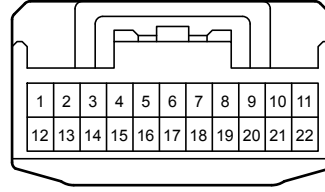

J 77  
Gray

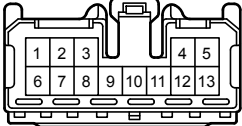

J 78  
White

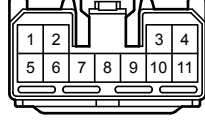

J 79  
White

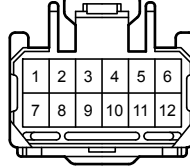

J 80  
White

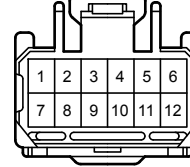

J113  
Gray

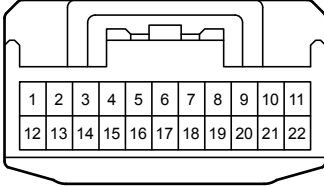

J117  
Black

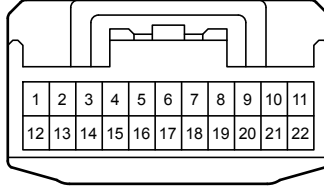

J118  
Gray

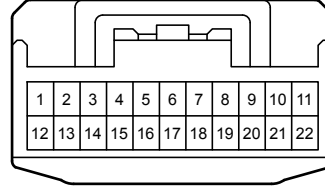

z 2  
Black

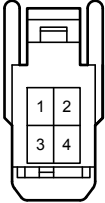

1B  
White

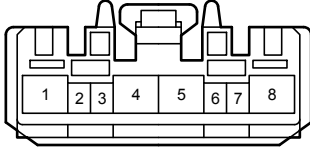

DD  
White

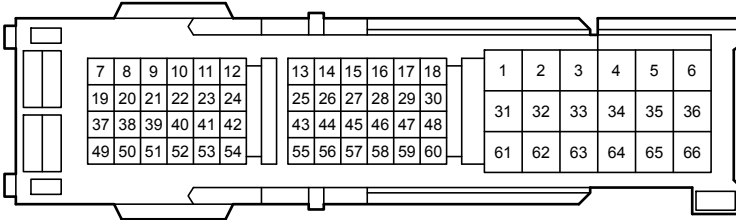

AJ3  
White

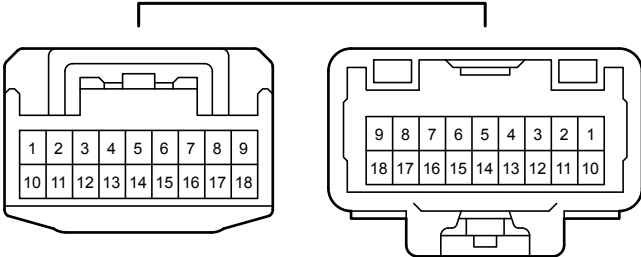



AJ4  
White

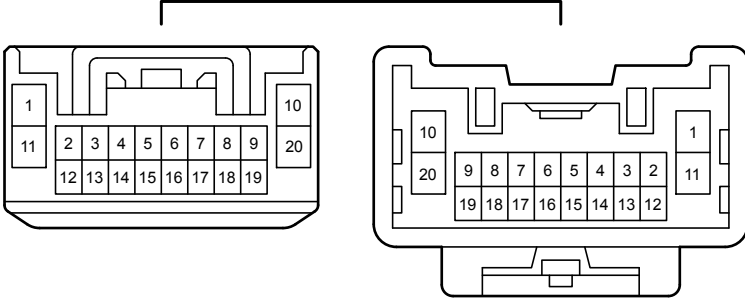

AJ5  
White

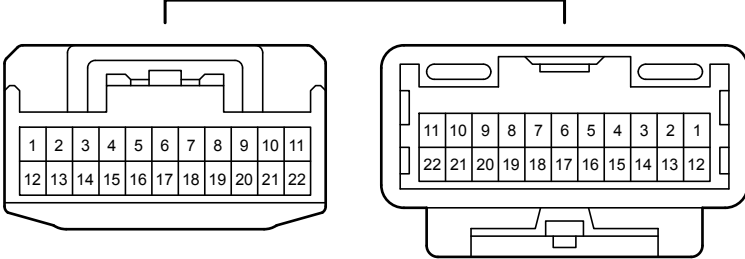

AJ10  
Gray

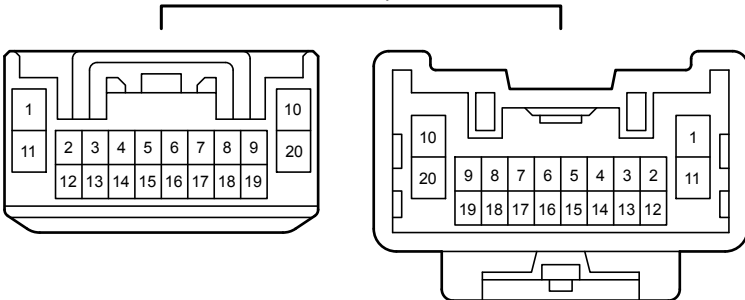

AJ11  
Gray

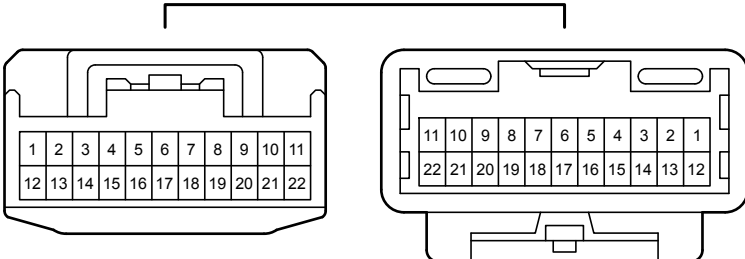

DA1  
White

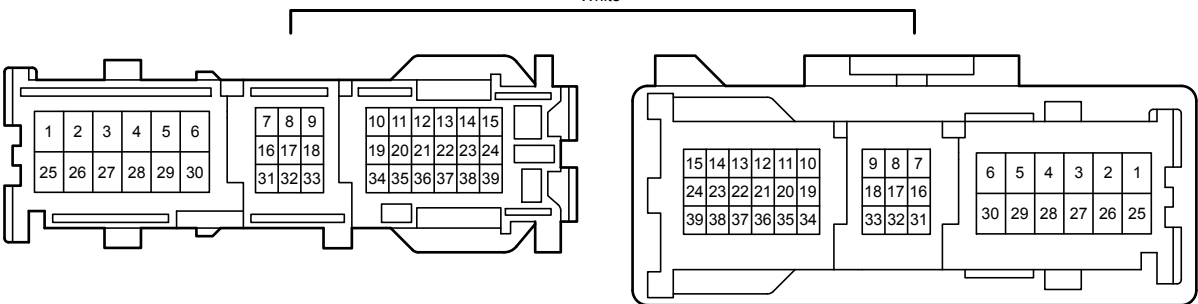

DA2  
White

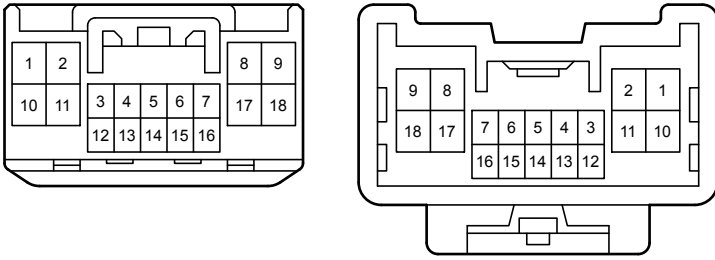

Climate Control Seat , Seat Heater <w/ Climate Control Seat>

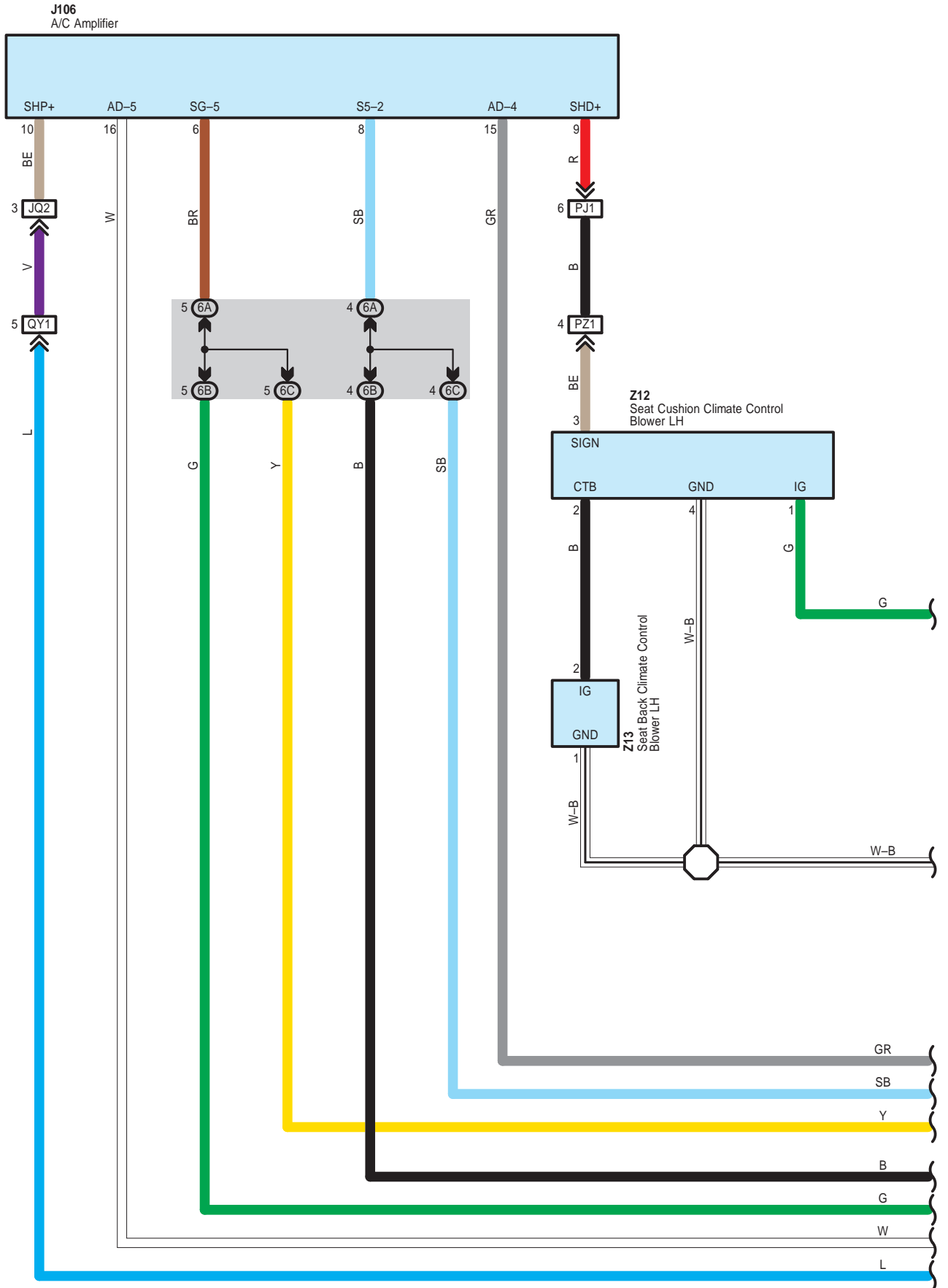

Climate Control Seat , Seat Heater <w/ Climate Control Seat>

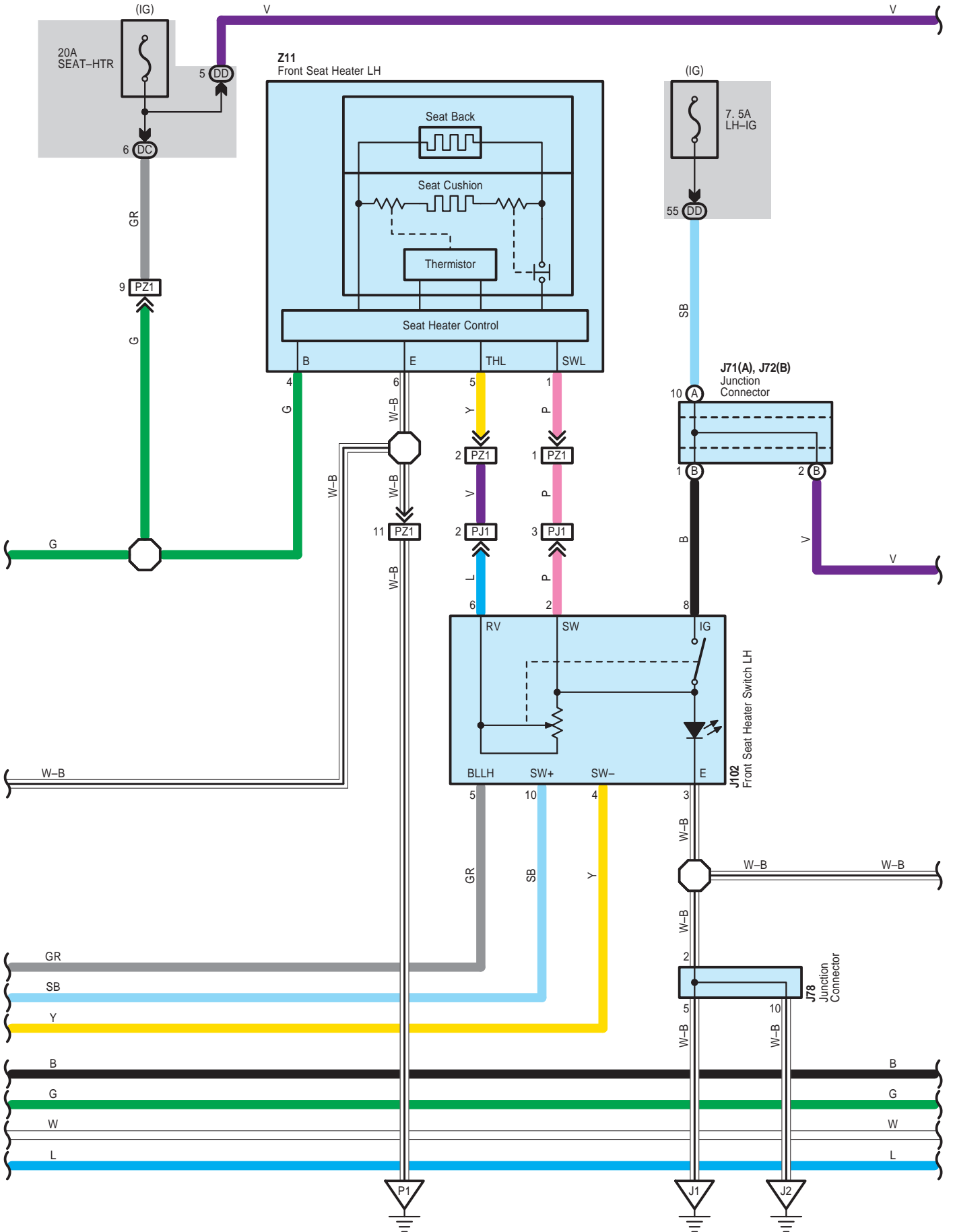

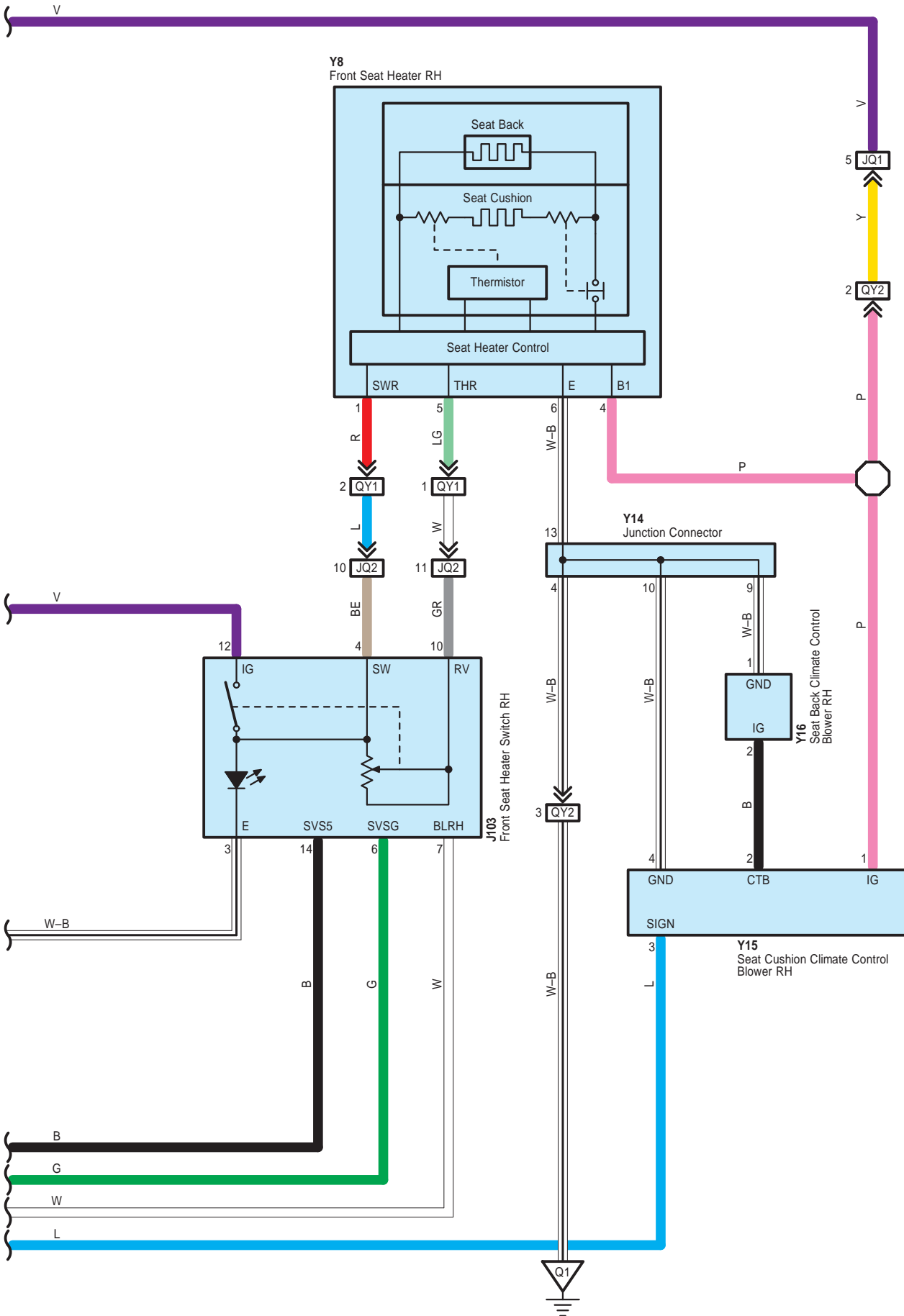

Climate Control Seat , Seat Heater <w/ Climate Control Seat>

J 71  
Black

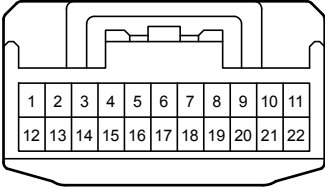

J 72  
Black

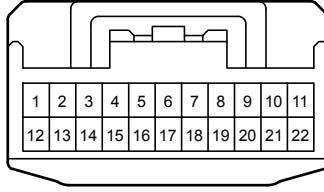

J 78  
White

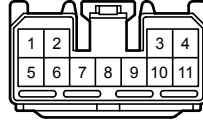

J102  
Black

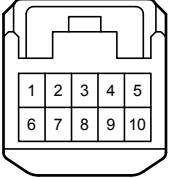

J103  
Black

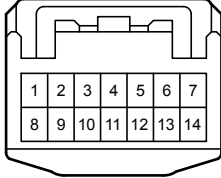

J106  
White

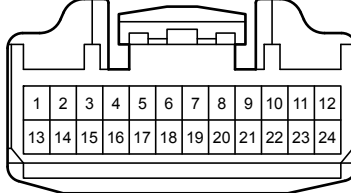

Y 8  
White



Y 14  
White

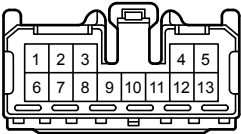

Y 15  
Black

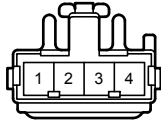

Y 16  
Black

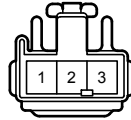

Z 11  
White

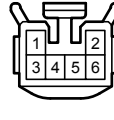

Z 12  
Black

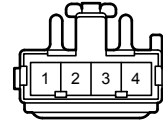

Z 13  
Black

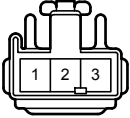

6A  
Black

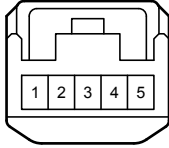

6B  
White

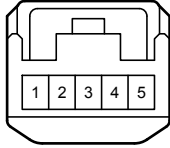

6C  
Blue

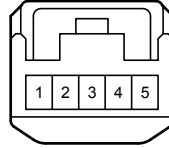

DC  
White

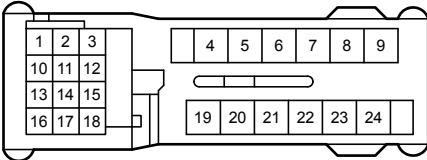

DD  
White

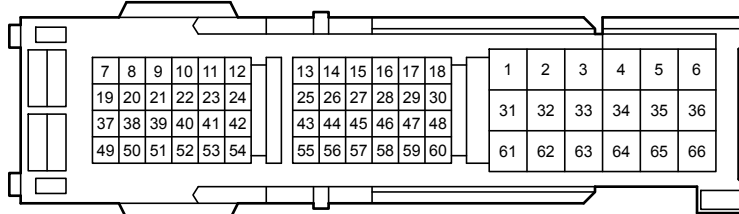

JQ1  
Gray

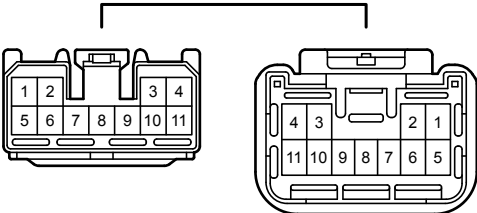

Climate Control Seat , Seat Heater <w/ Climate Control Seat>

JQ2  
Gray

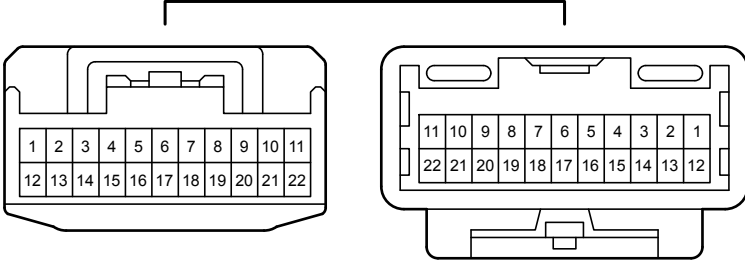

PJ1  
Black

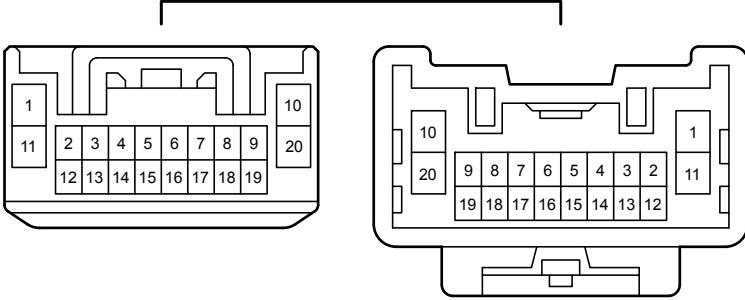

PZ1  
White

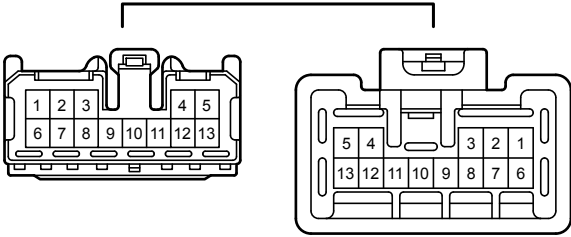

QY1  
White

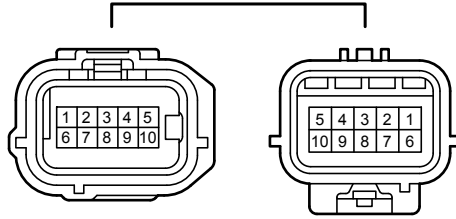

QY2  
White

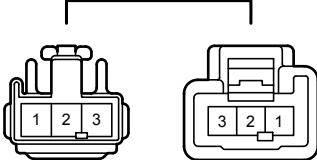

# Combination Meter

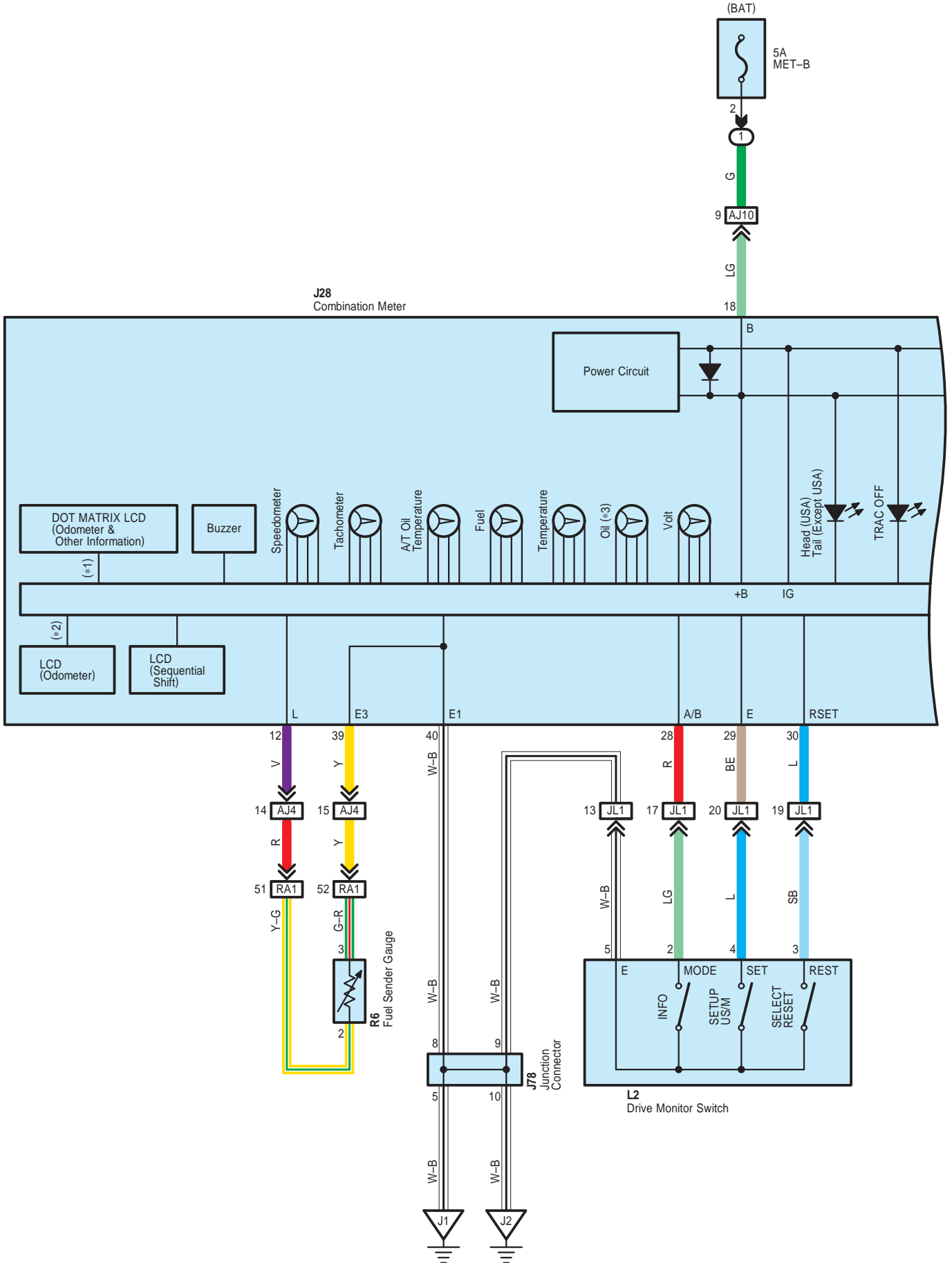



# Combination Meter

- \* 1 : Optitron Meter
- \* 2 : Except Optitron Meter
- \* 3 : w/ Oil Pressure Gauge
- \* 4 : w/o Oil Pressure Gauge
- \* 7 : 1GR-FE
- \*10 : 3UR-FE, 3UR-FBE, 1UR-FE

**J28**  
Combination Meter

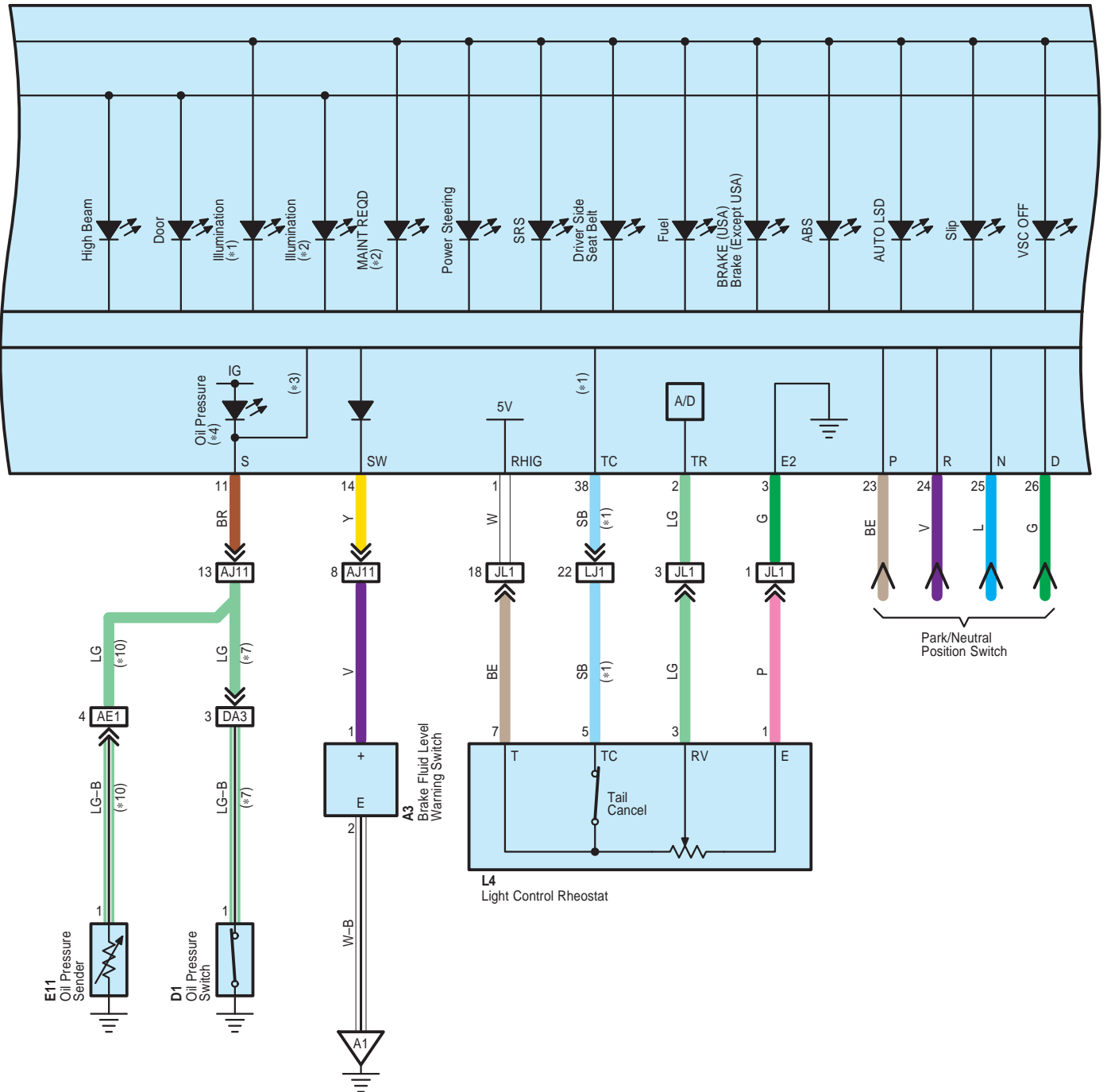

# Combination Meter

- \* 1 : Optitron Meter
- \* 2 : Except Optitron Meter

**J28**  
Combination Meter

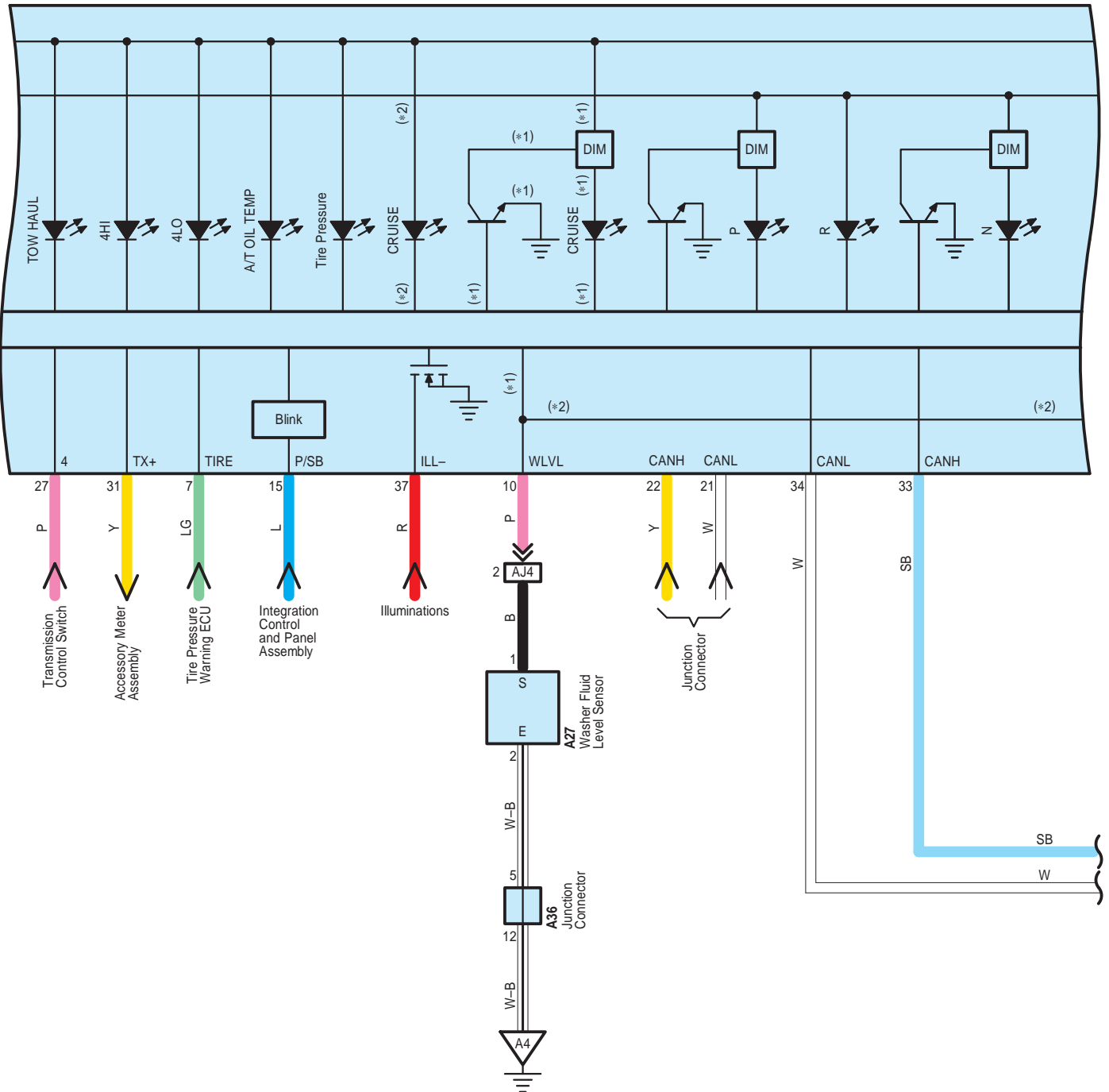

Combination Meter

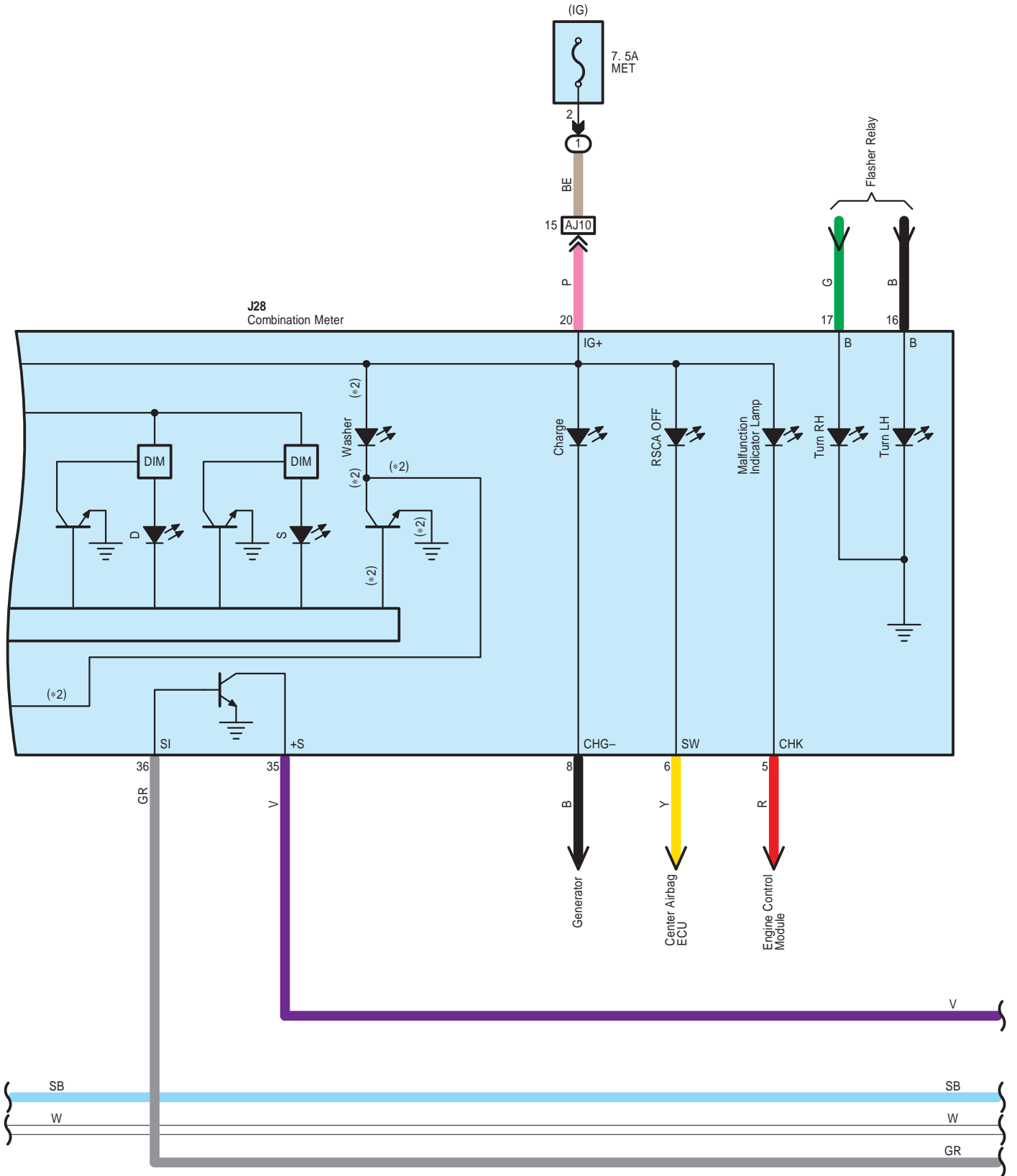



Combination Meter

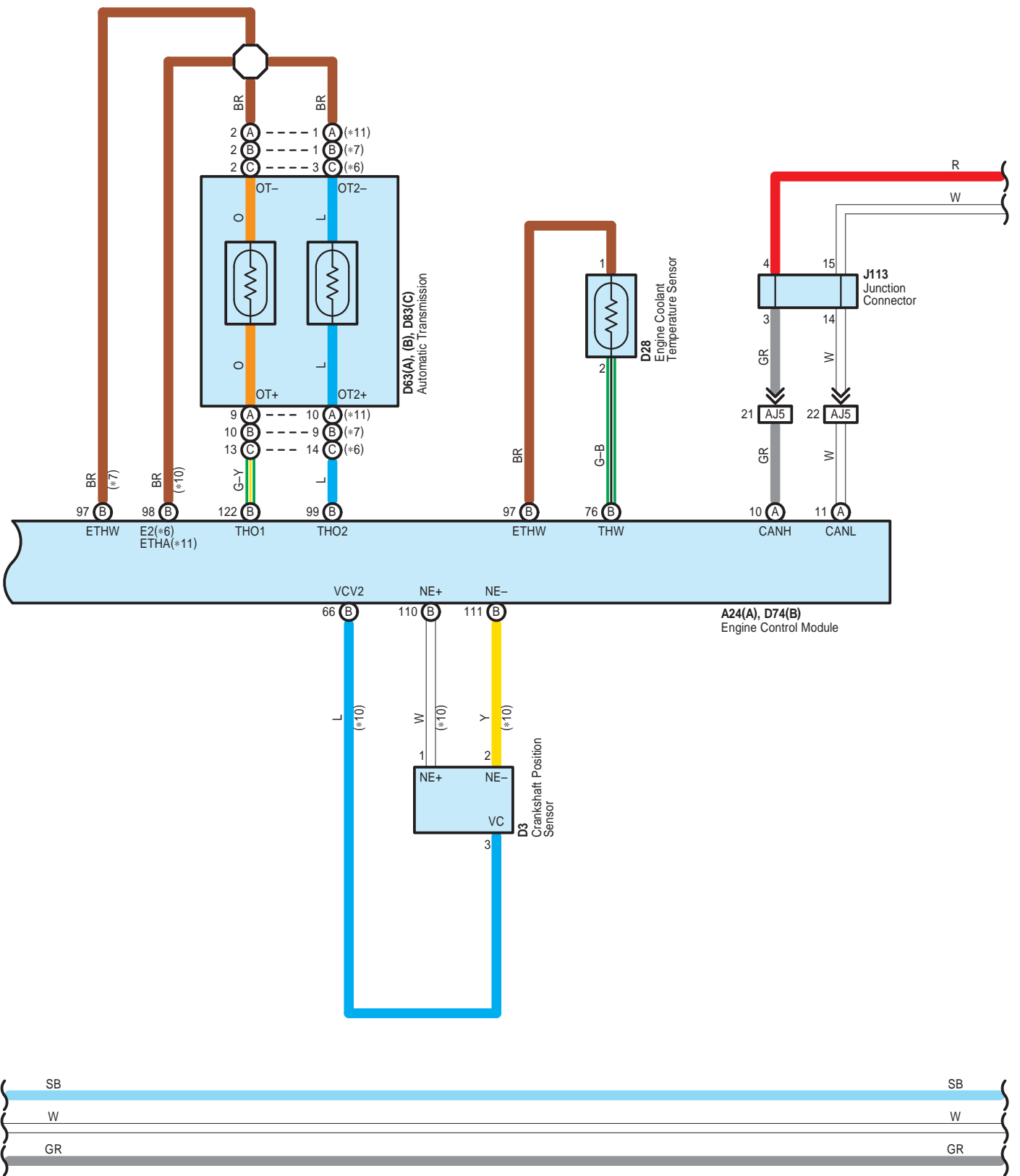

Combination Meter

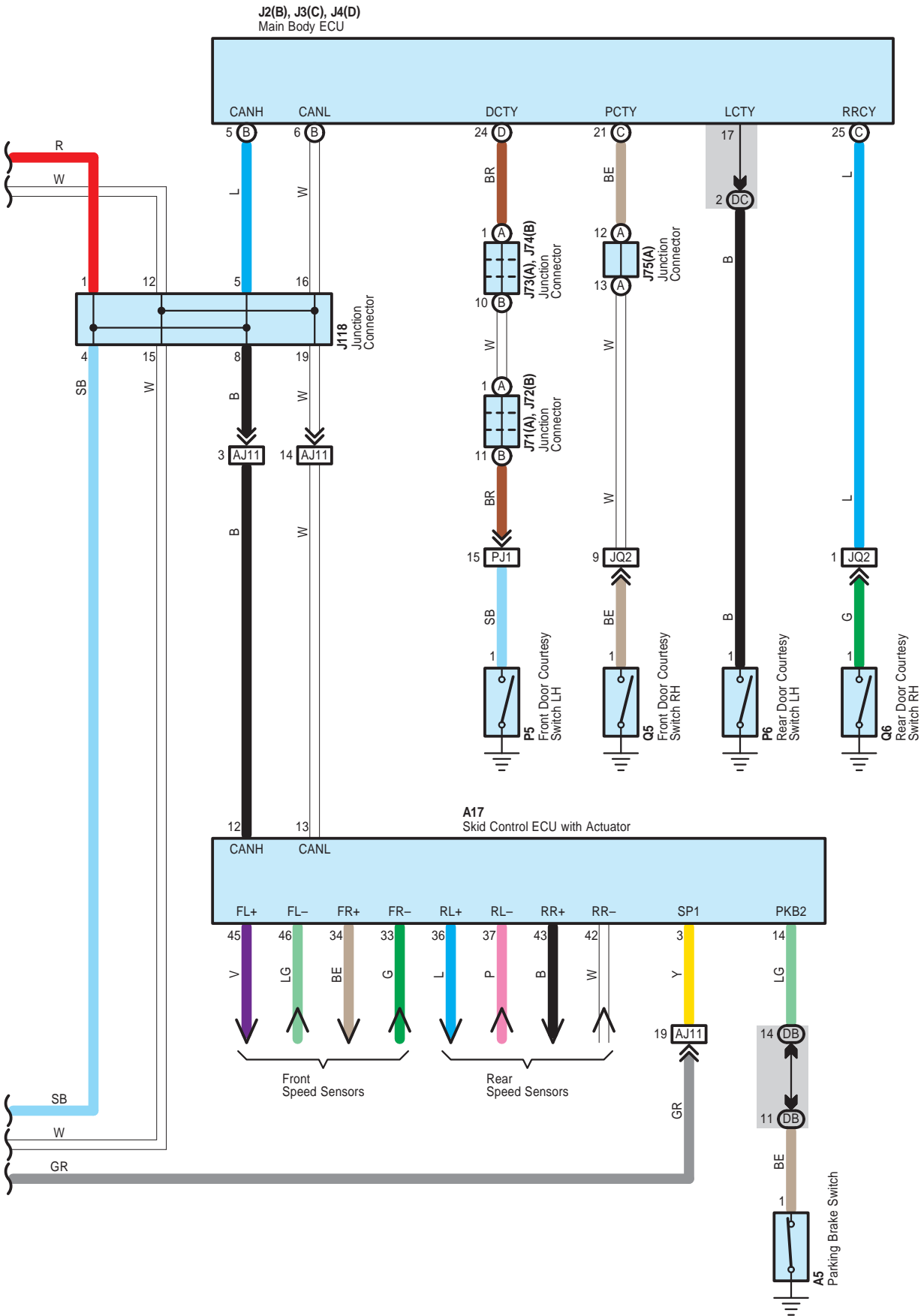

# Combination Meter

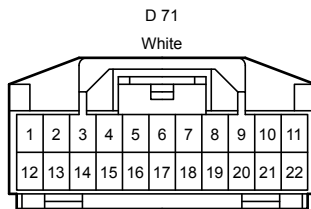
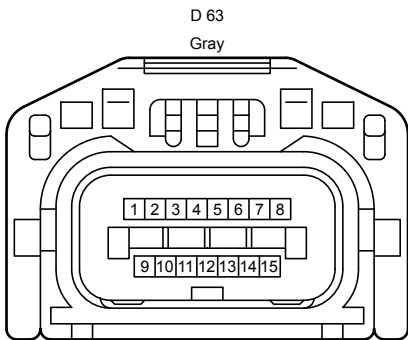
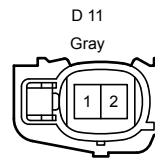
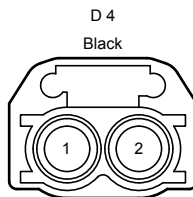
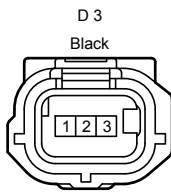
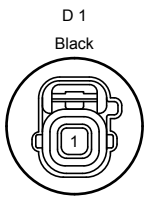
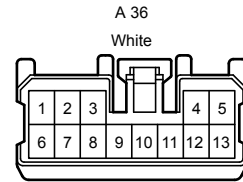
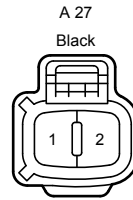
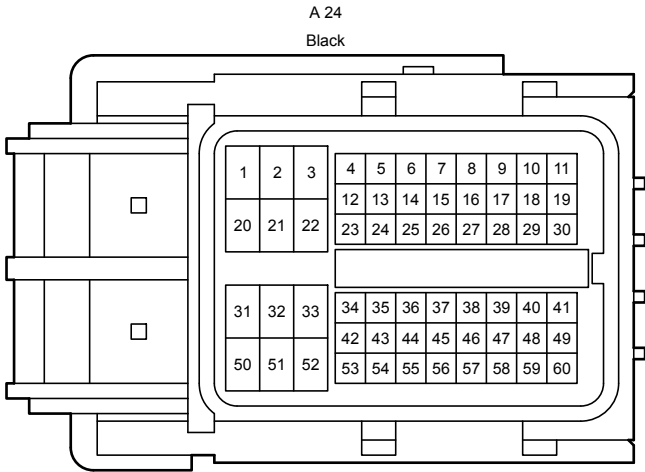
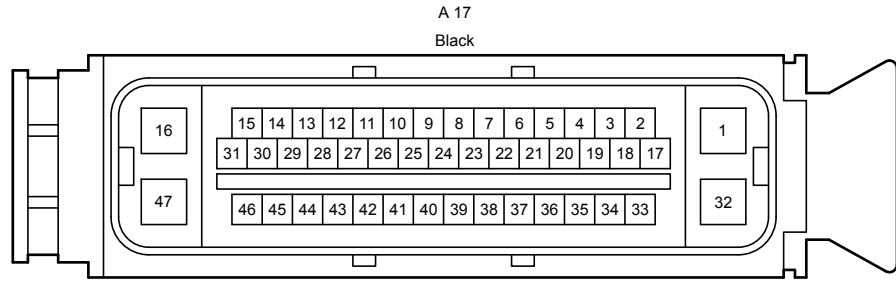

Combination Meter

D 74  
Black

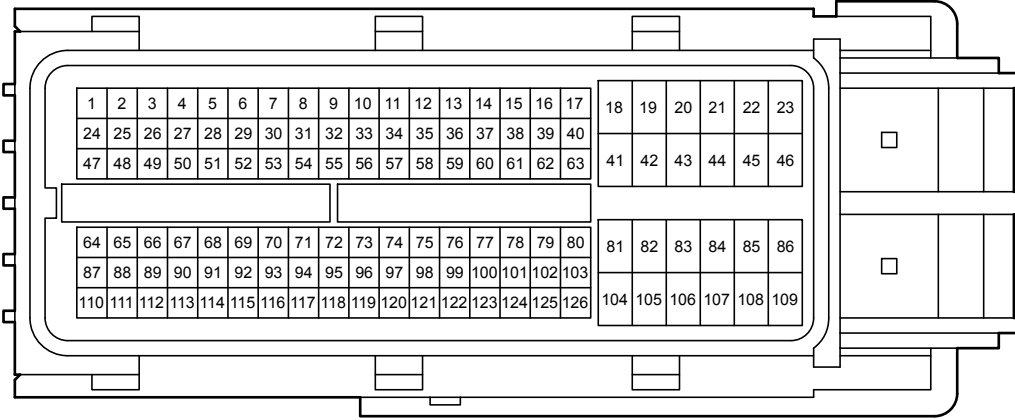

D 83  
Gray

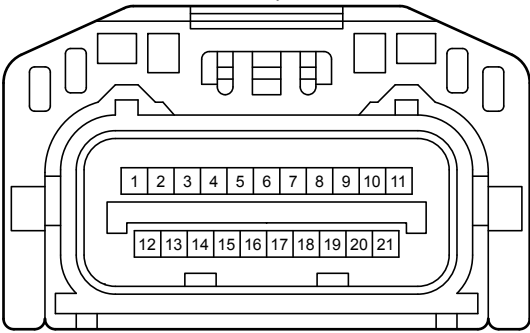

E 11  
Black



H 1  
Black

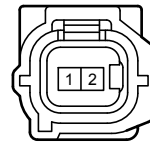

J 2  
White

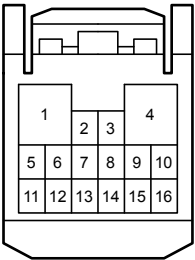

J 3  
White

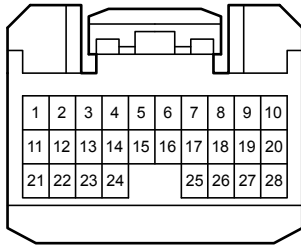

J 4  
White

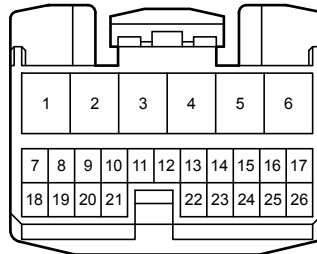

J 28  
White

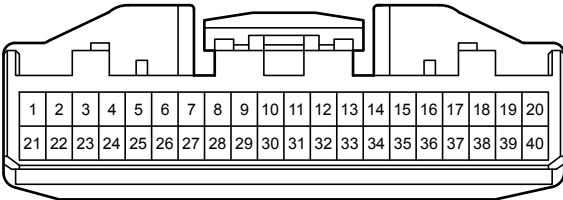

J 31  
White

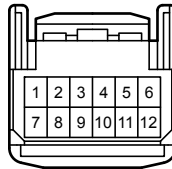

J 35  
White

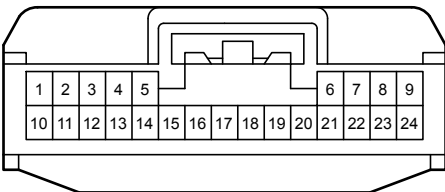

J 71  
Black

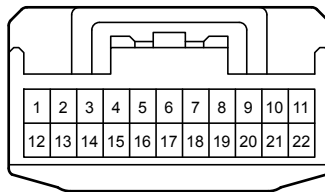



Combination Meter

J 72  
Black

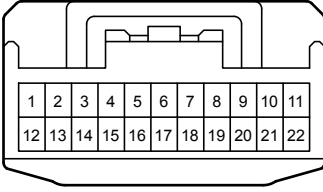

J 73  
Black

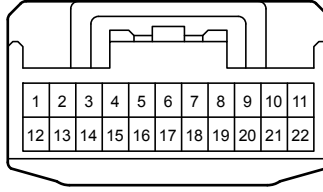

J 74  
Black

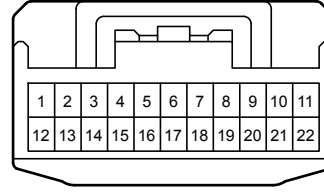

J 75  
White

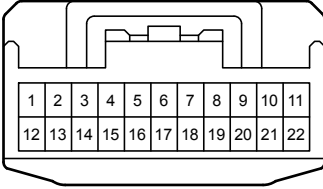

J 78  
White

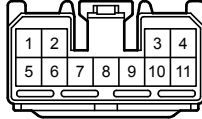

J113  
Gray

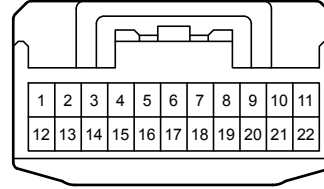

J118  
Gray

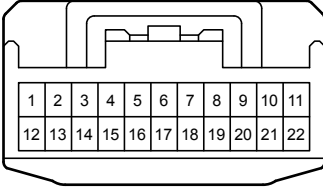

K 3  
White

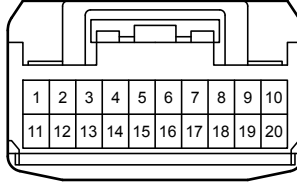

K 6  
Gray

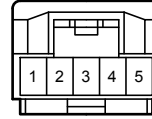

K 15  
White

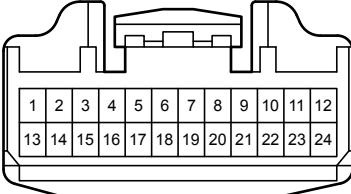

K 21  
White

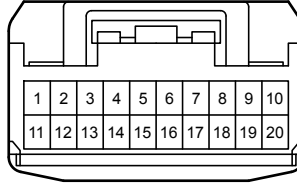

L 2  
Black

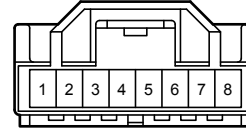

L 4  
White

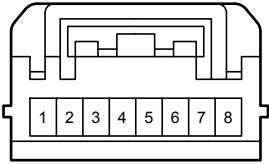

P 5  
White



P 6  
White



Q 5  
White



Q 6  
White



R 6  
White

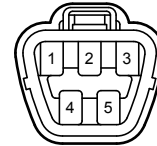

DB  
White

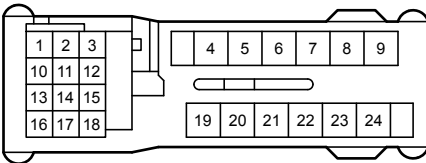

DC  
White

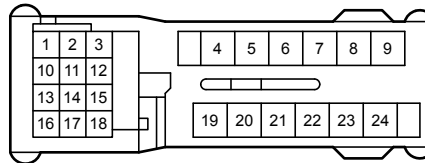

Combination Meter

AE1  
Gray

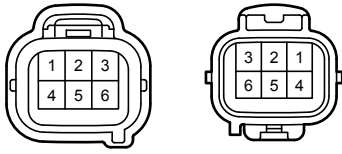

AJ4  
White

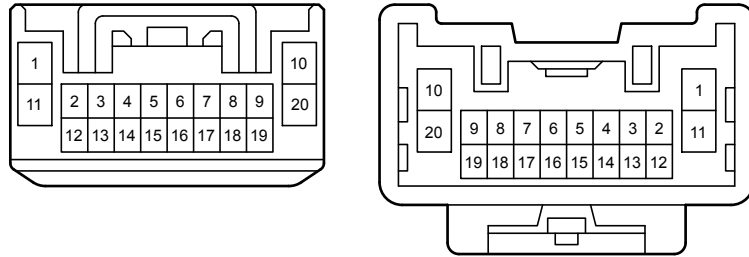

AJ5  
White

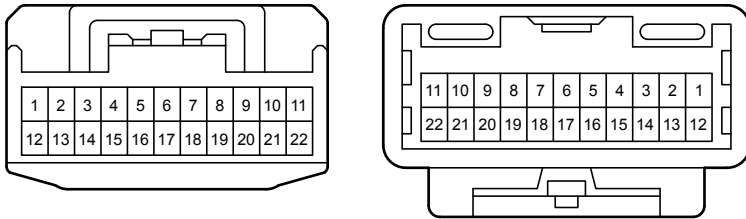

AJ10  
Gray

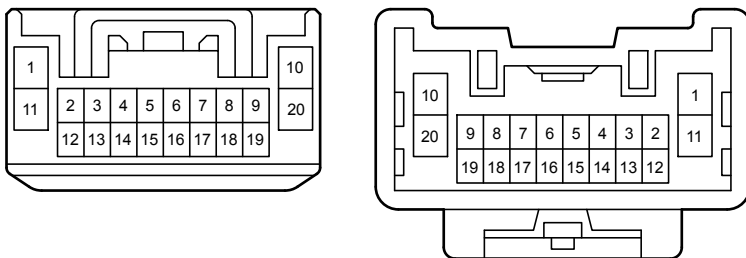

AJ11  
Gray

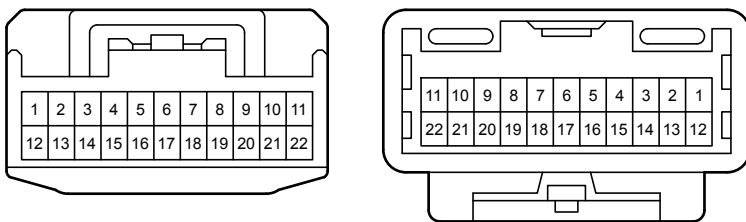

DA2  
White

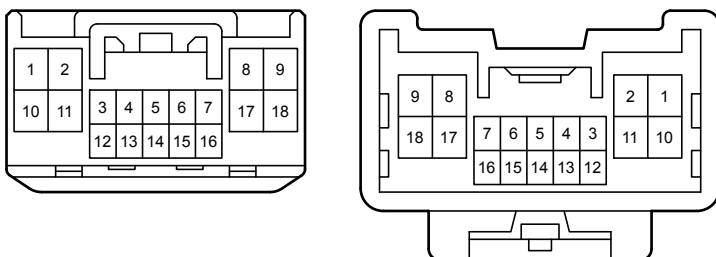

Combination Meter

DA3  
White

DH1  
Gray

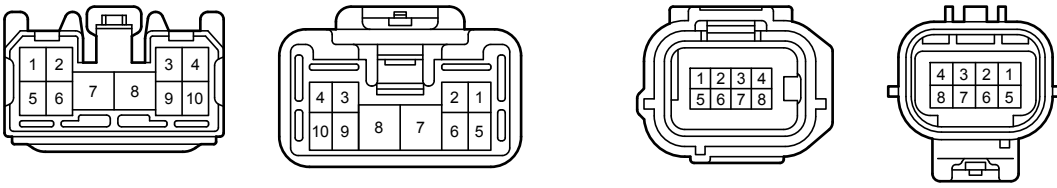

JK1  
White

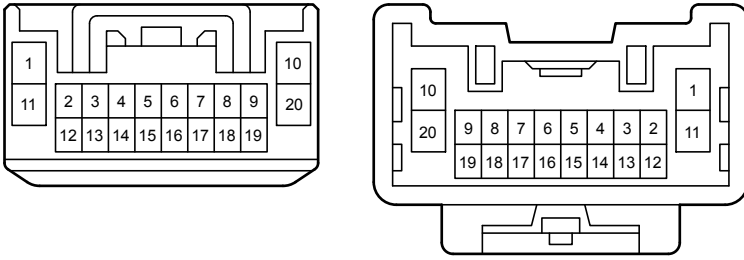

JL1  
White

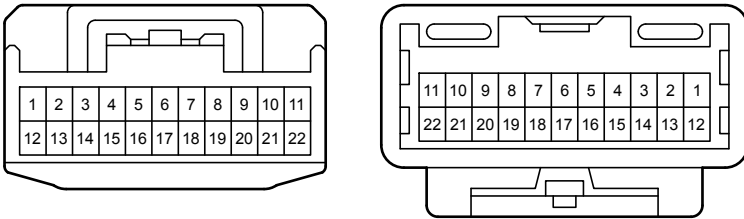

JQ2  
Gray

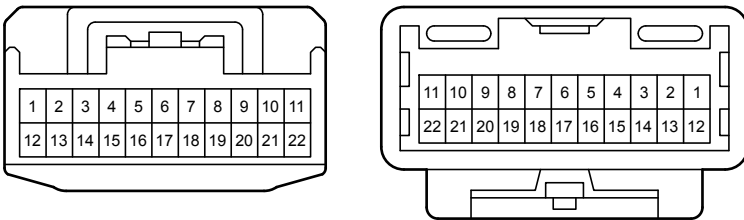

LJ1  
White

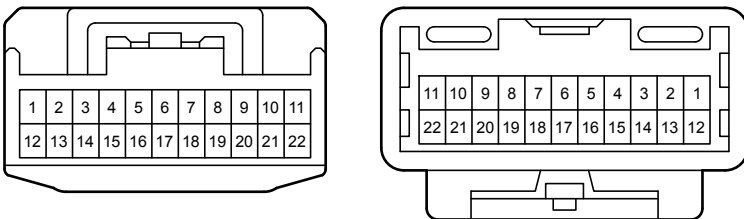

Combination Meter

PJ1  
Black

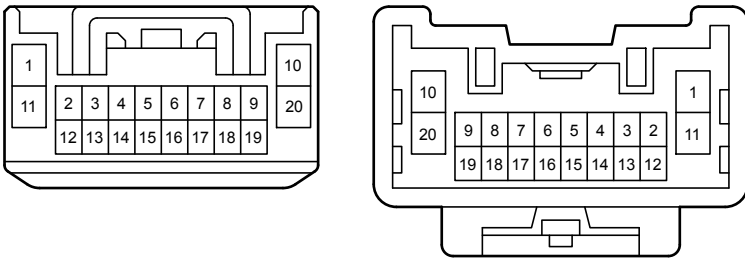

RA1  
White

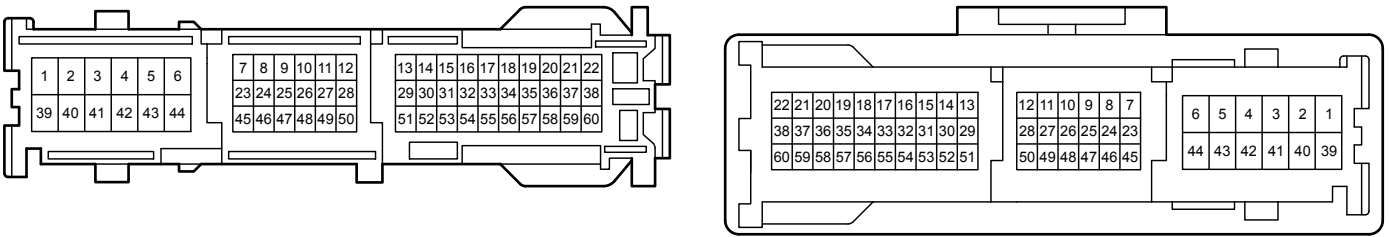

# Charging

- \* 3 : 3UR-FE, 3UR-FBE, 1UR-FE
- \* 4 : 1GR-FE
- \* 5 : 1GR-FE Before Oct. 2010 Production
- \* 6 : 1GR-FE From Oct. 2010 Production

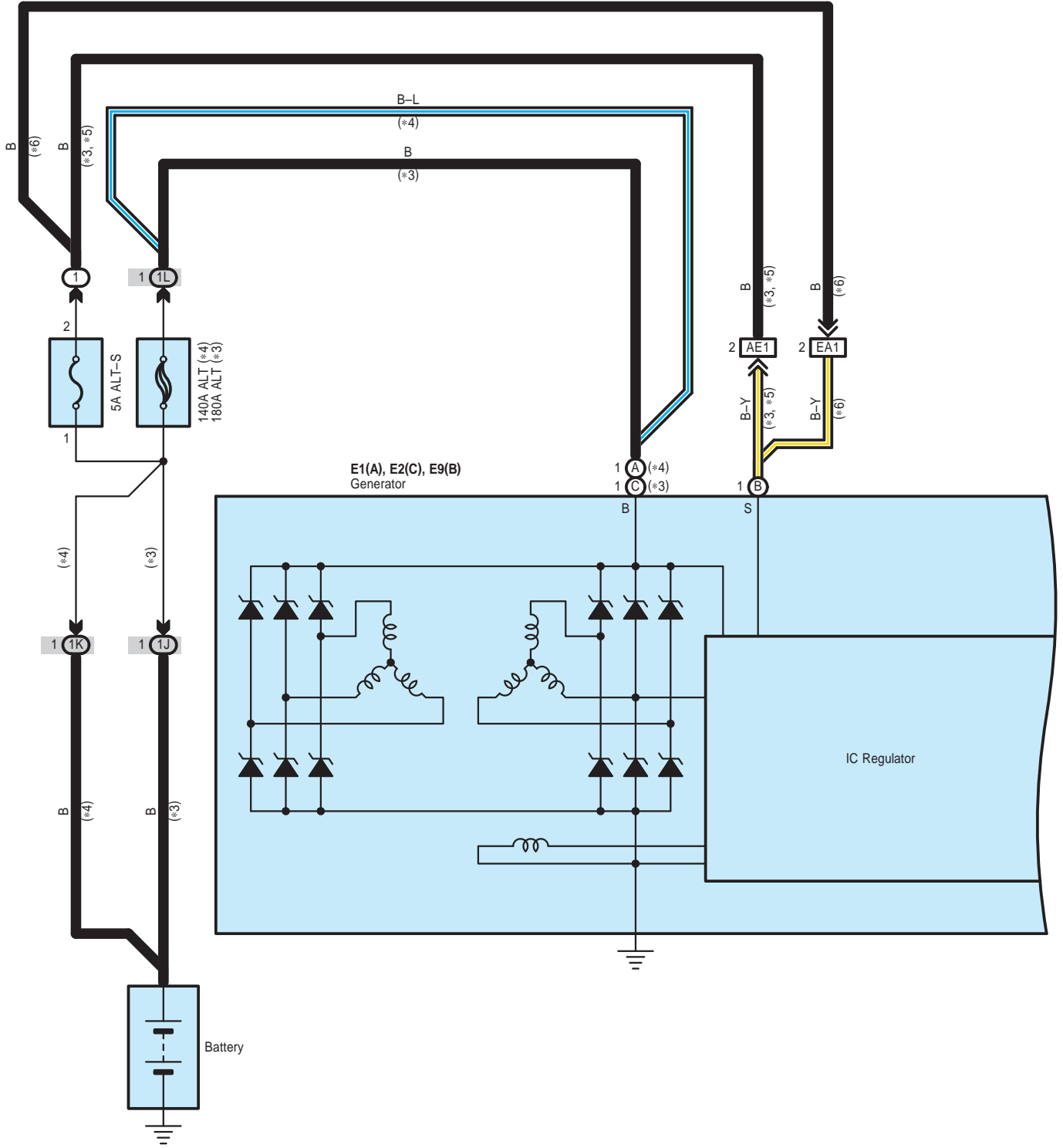

Charging

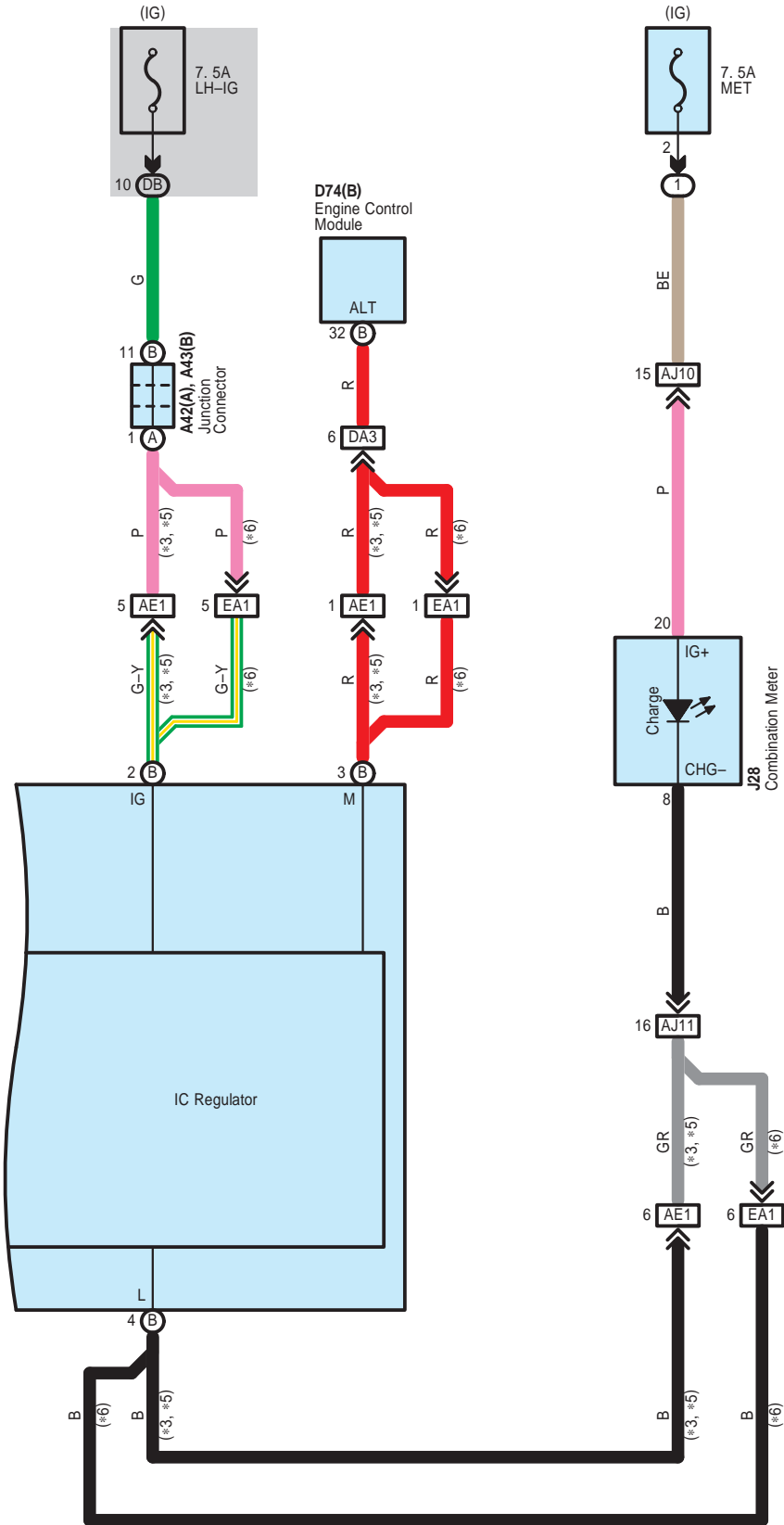

# Charging

A 42  
White

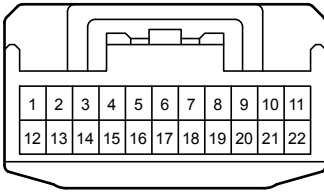

A 43  
White

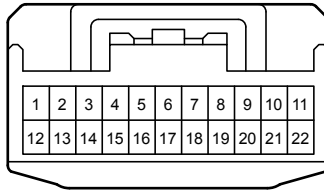

D 74  
Black

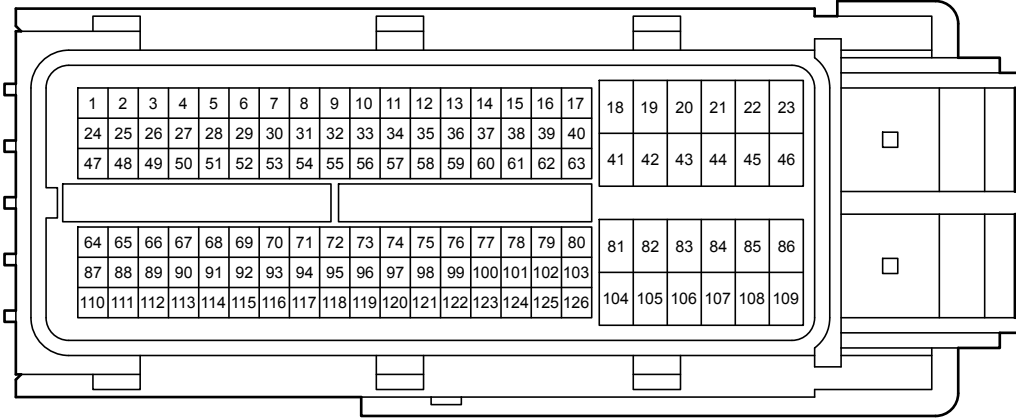

E 1

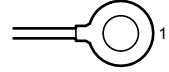

E 2

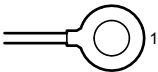

E 9

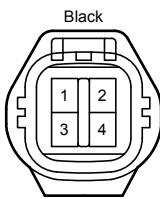

J 28

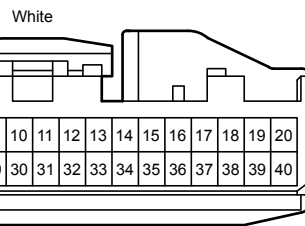

1J

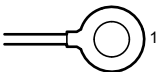

1K

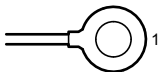

1L

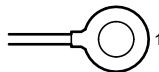

DB

White

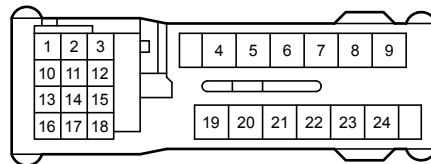

AE1

Gray

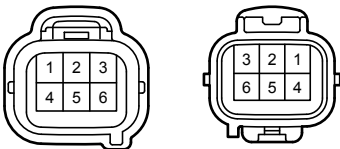

AJ10

Gray

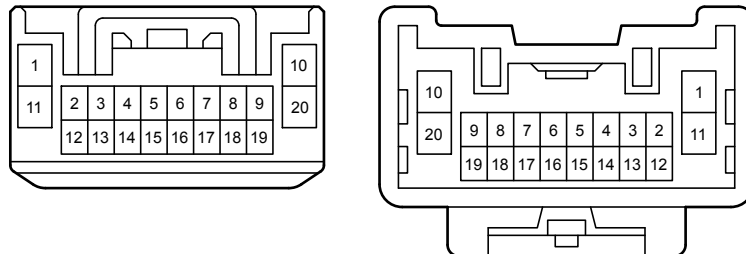

# Charging

AJ11  
Gray

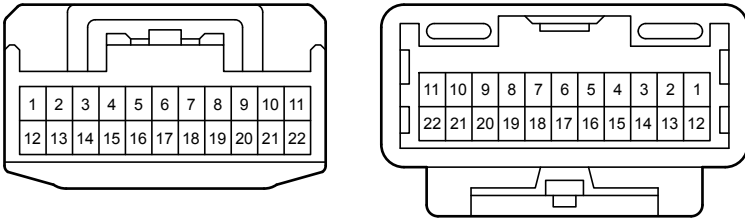

DA3  
White

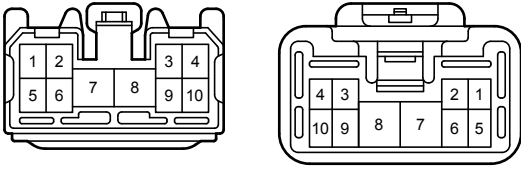

EA1  
Gray

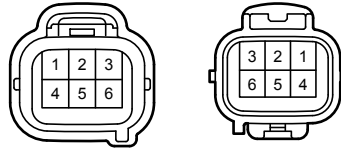



# Door Lock Control

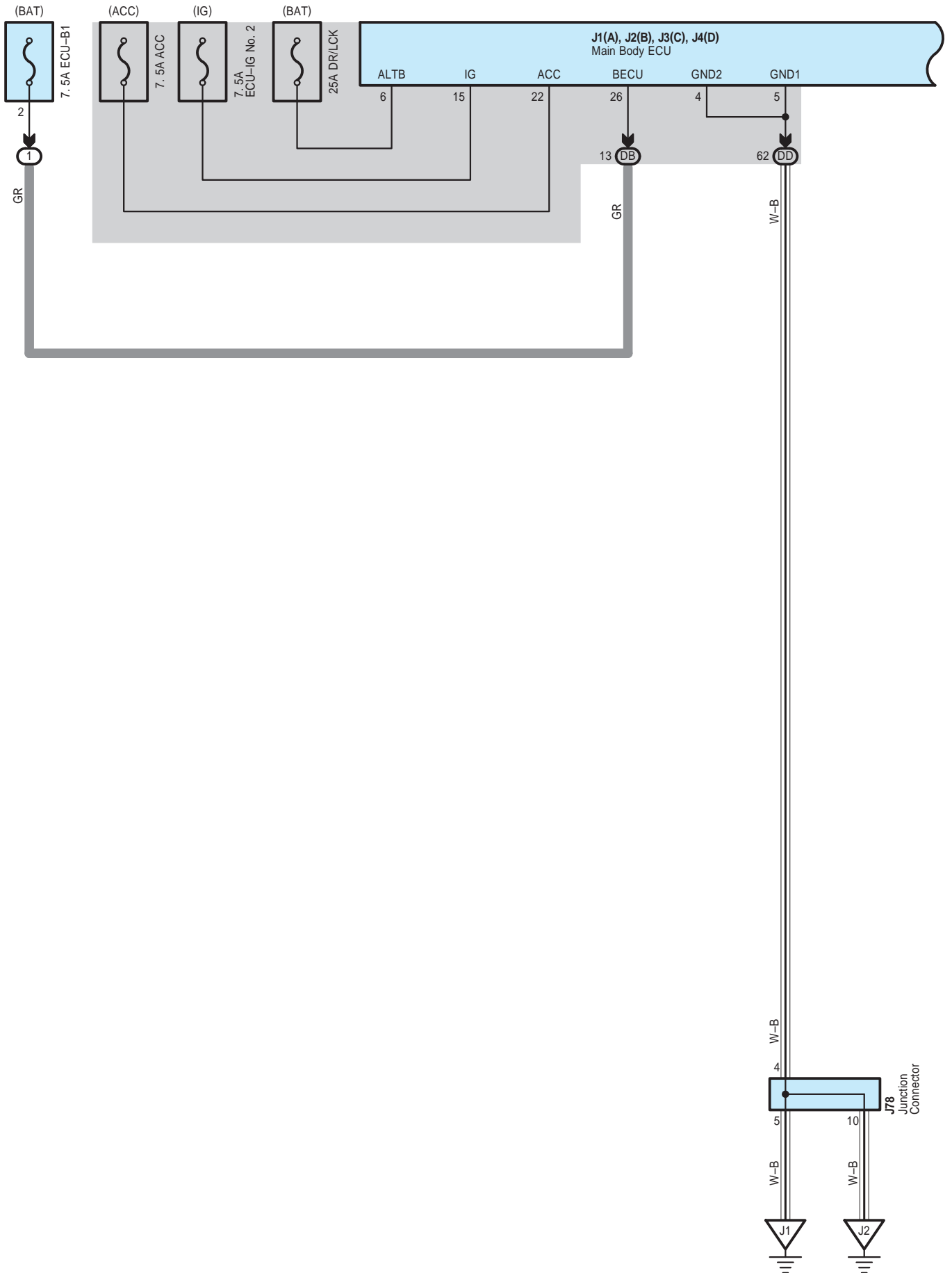

Door Lock Control

J1(A), J2(B), J3(C), J4(D)  
Main Body ECU

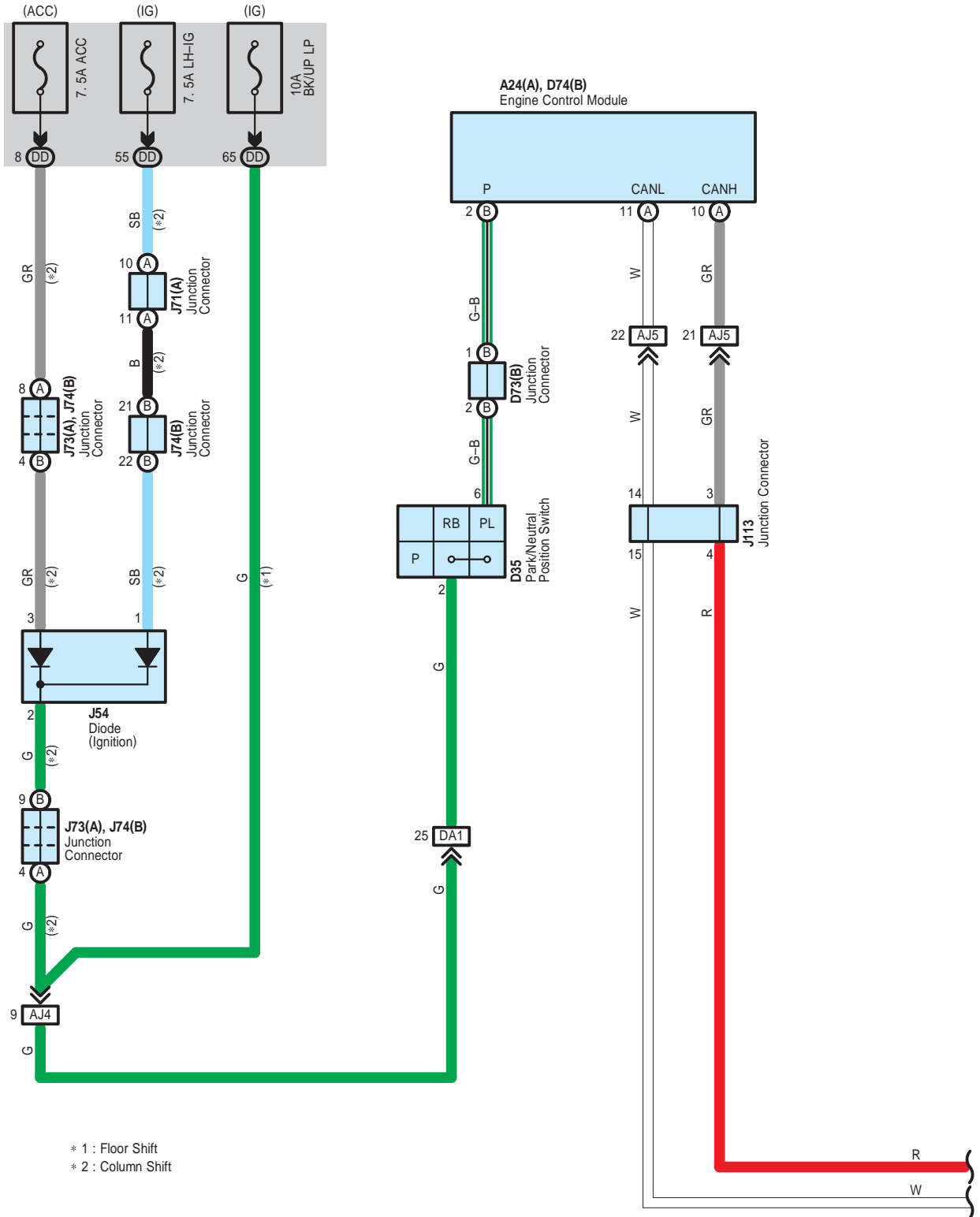

Door Lock Control

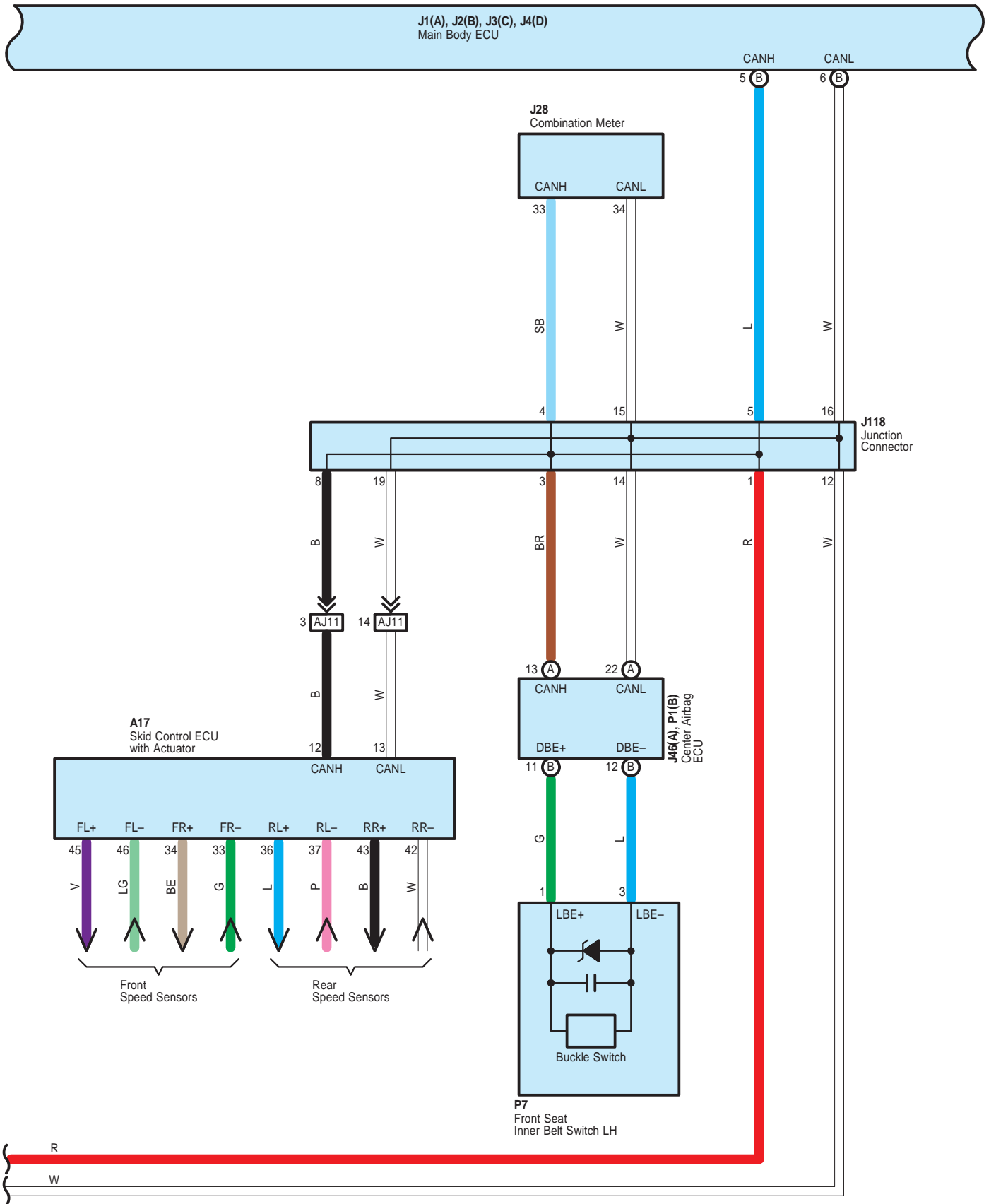

# Door Lock Control

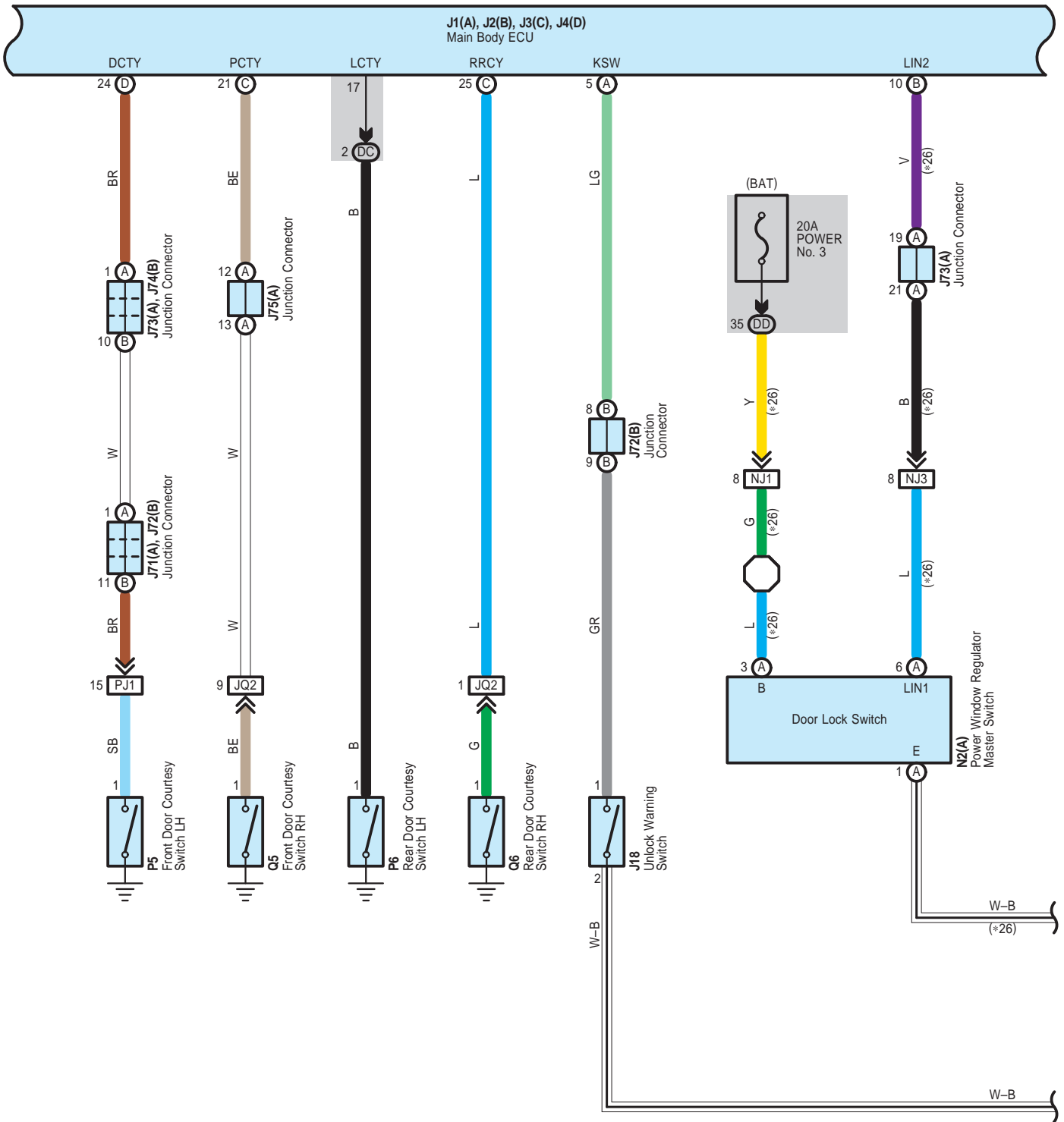

\*26 : w/ Auto Up

# Door Lock Control

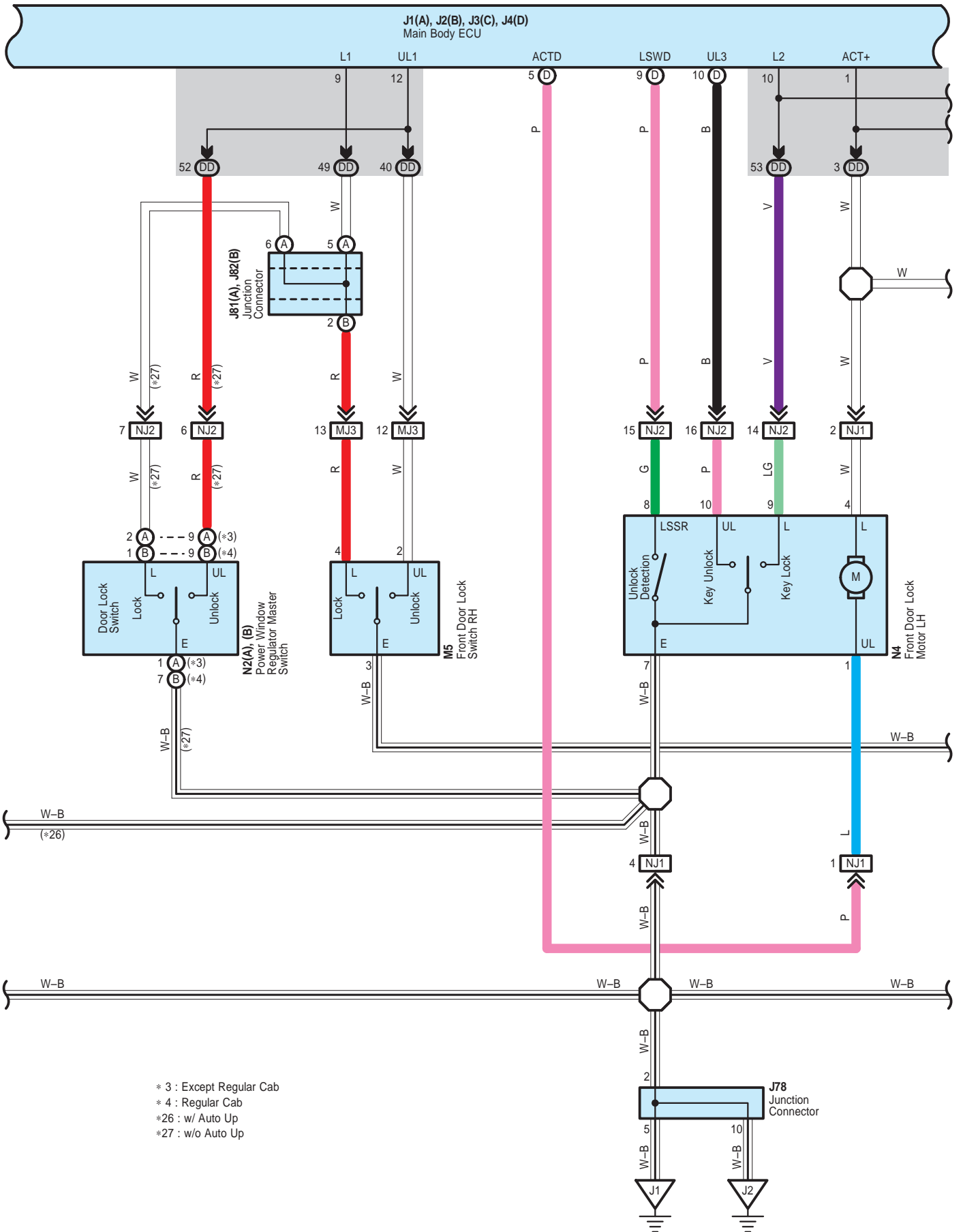

- \* 3 : Except Regular Cab
- \* 4 : Regular Cab
- \*26 : w/ Auto Up
- \*27 : w/o Auto Up

# Door Lock Control

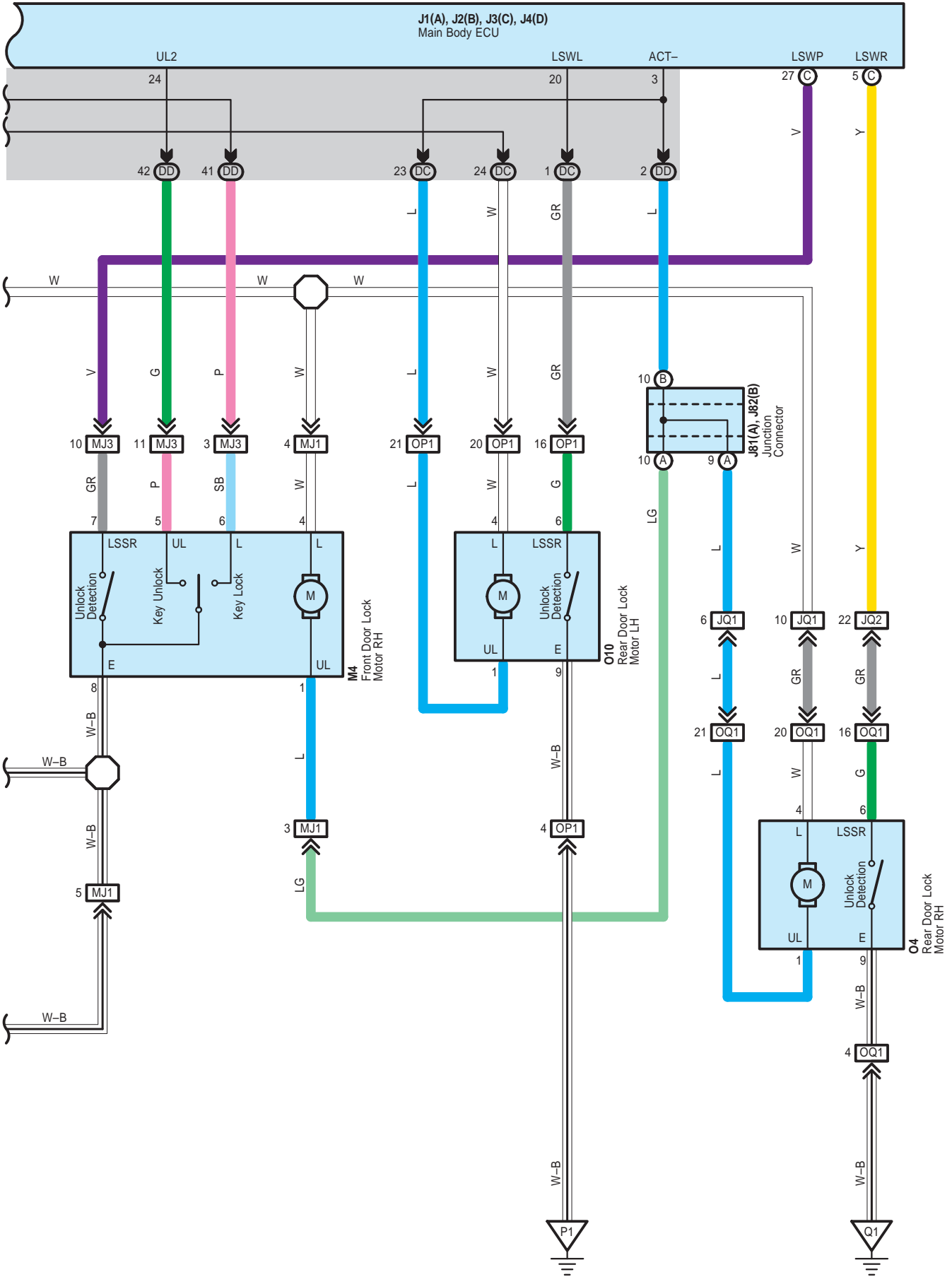



## Door Lock Control

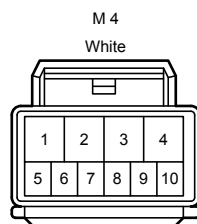
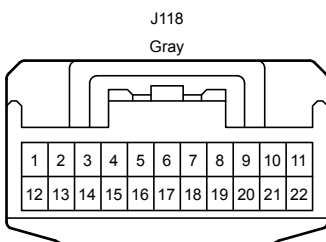
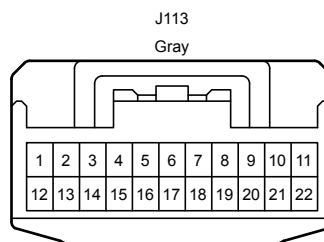
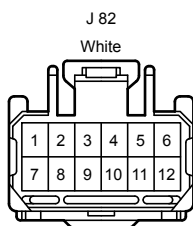
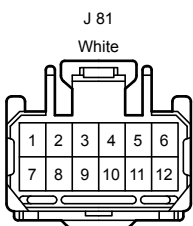
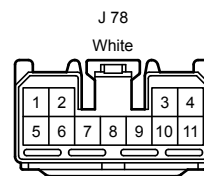
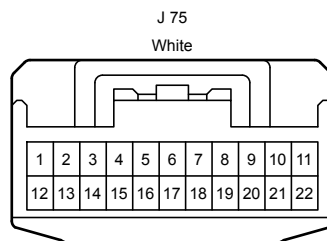
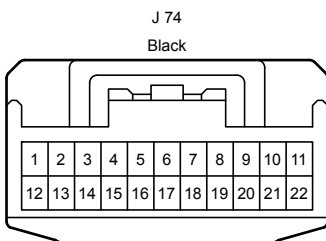
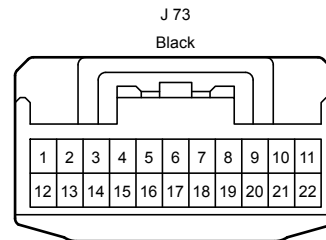
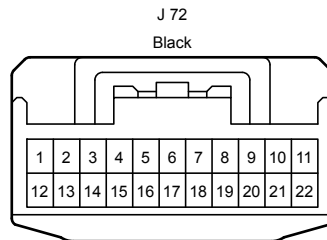
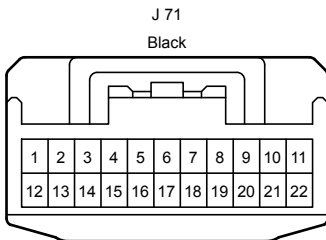
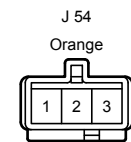
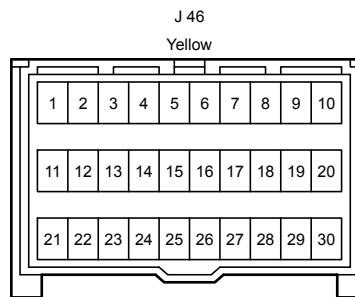
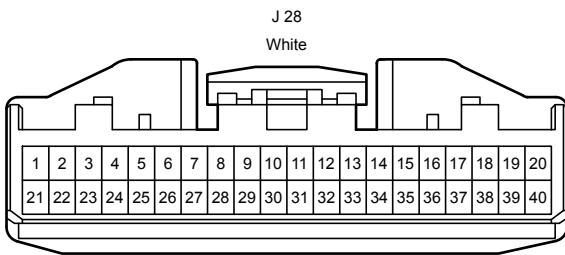
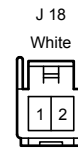
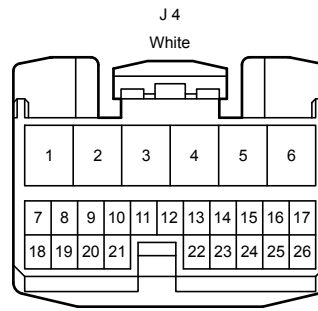
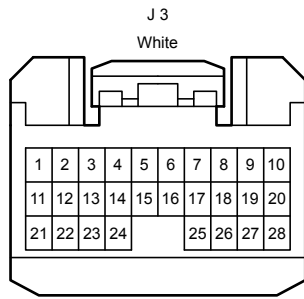
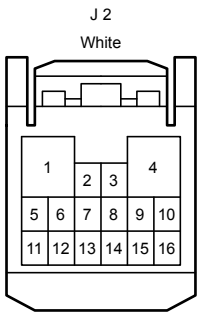



## Door Lock Control

N 2  
White

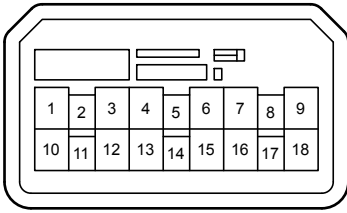

N 4  
White

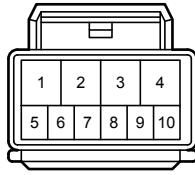

O 4  
White

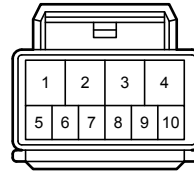

O 10  
White

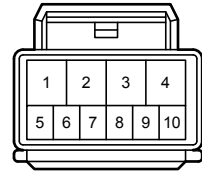

P 1  
Yellow

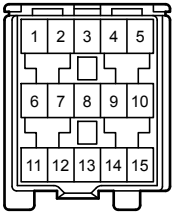

P 5  
White



P 6  
White



P 7  
White



Q 5  
White



Q 6  
White



DB  
White

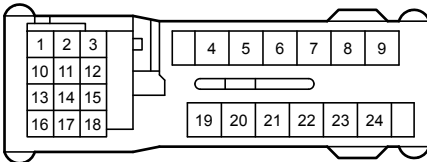

DC  
White

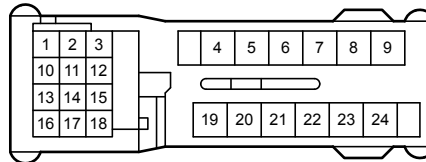

DD  
White

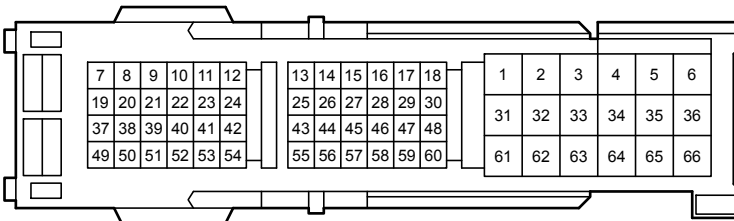

AJ4  
White

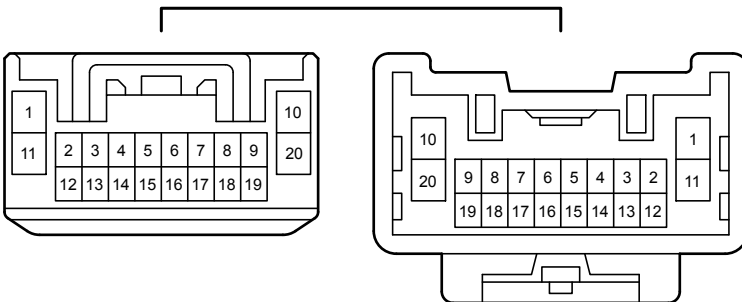

Door Lock Control

AJ5  
White

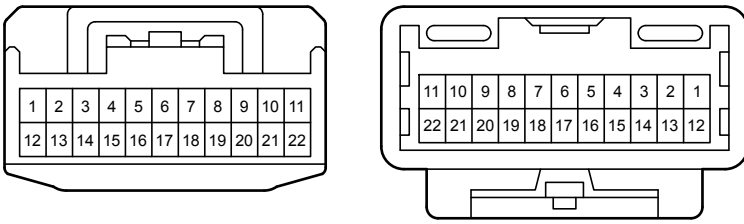

AJ11  
Gray

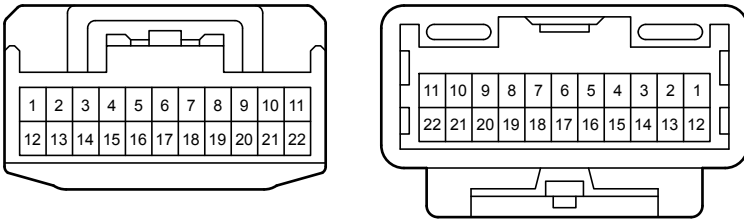

DA1  
White

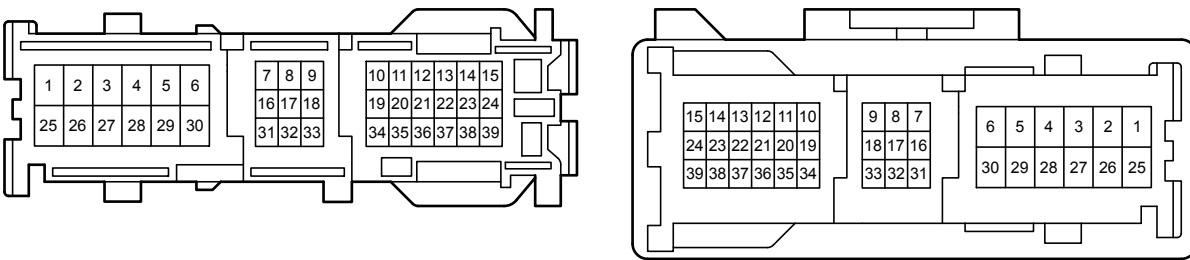

JQ1  
Gray

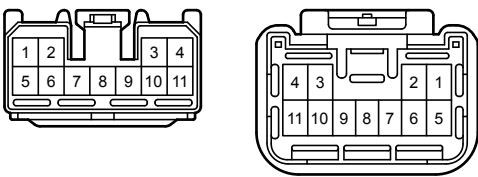

JQ2  
Gray

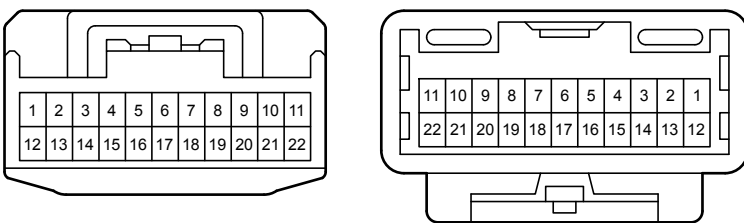

MJ1  
Blue

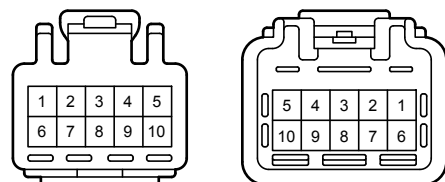

Door Lock Control

MJ3  
Blue

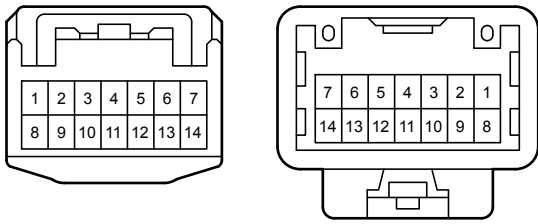

NJ1  
Blue

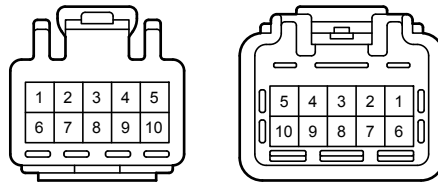

NJ2  
Blue

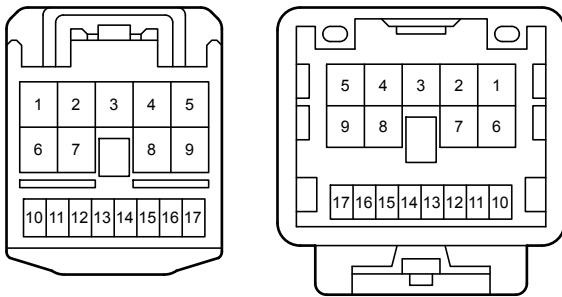

NJ3  
Blue

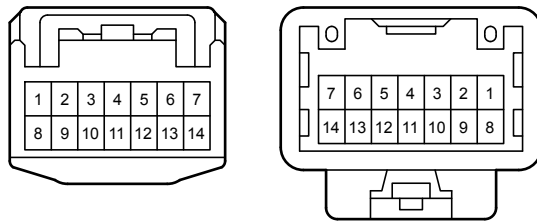

OP1  
White

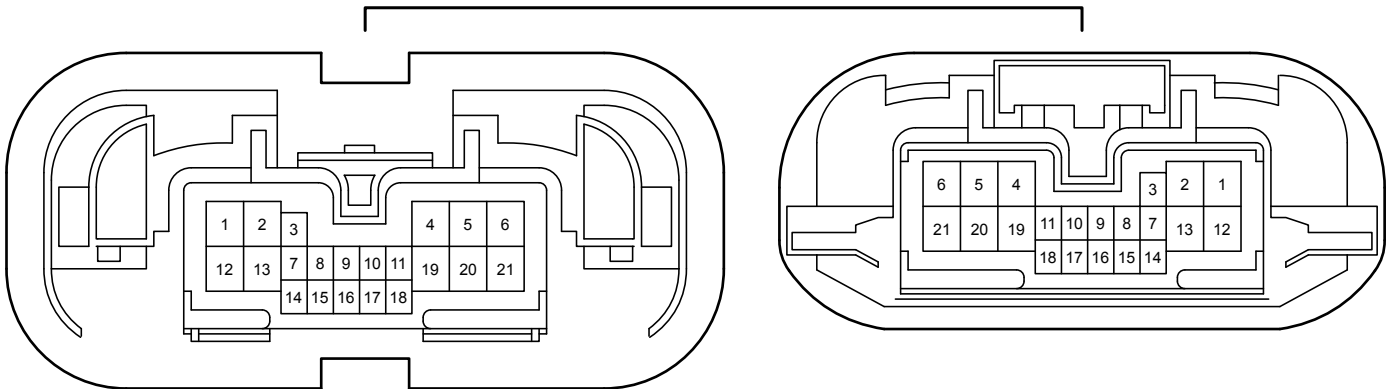

OQ1  
White

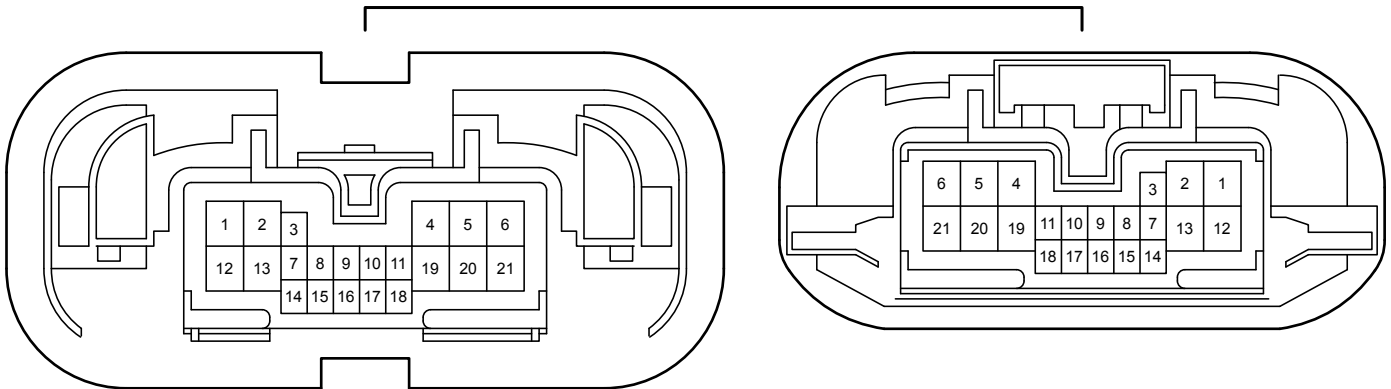

Door Lock Control

PJ1  
Black

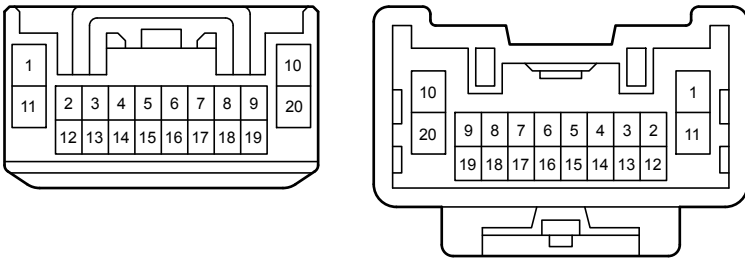

Data Link Connector 3

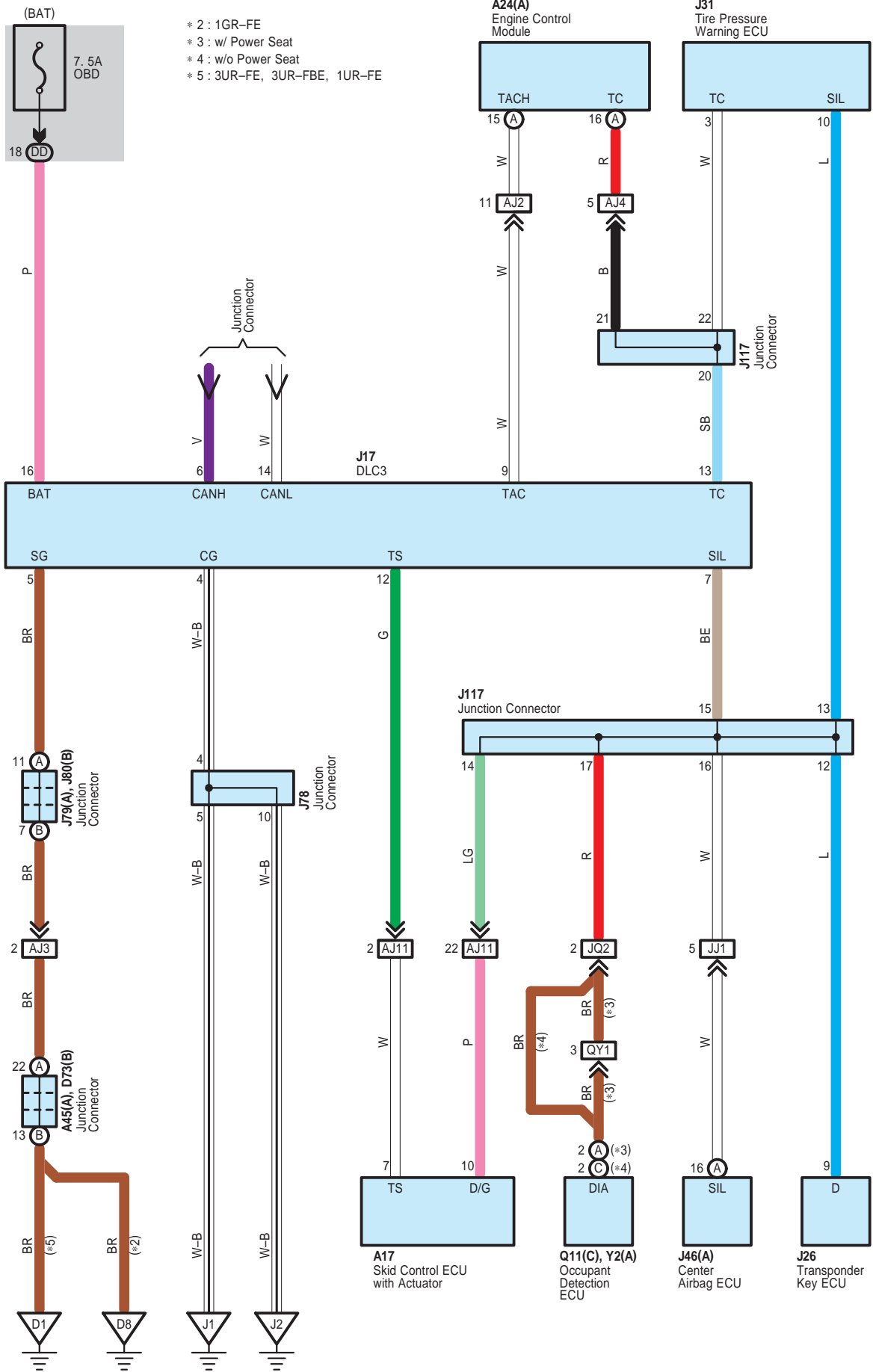

Data Link Connector 3

A 17  
Black

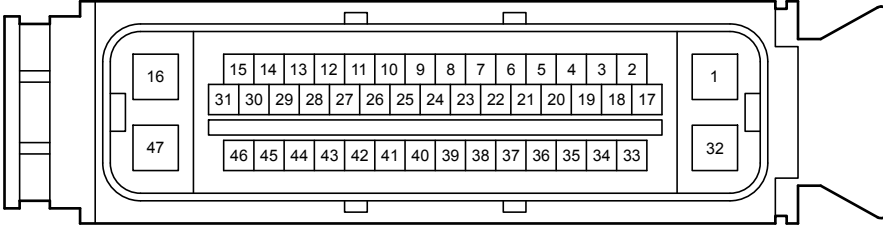

A 24  
Black

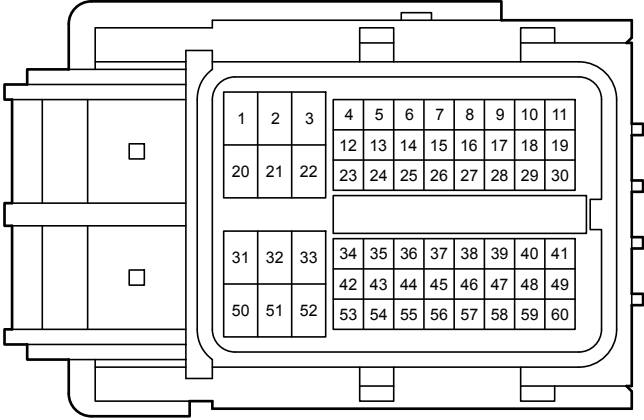

A 45  
Blue

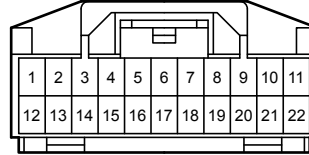

D 73  
Blue

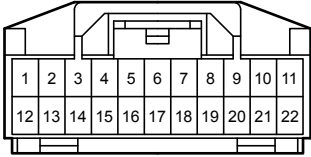

J 17  
White

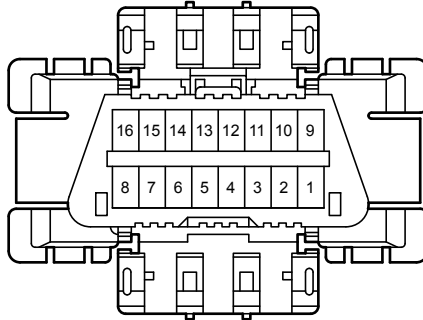

J 26  
White

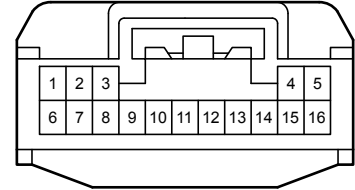

J 31  
White

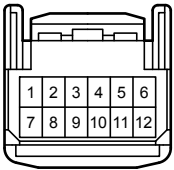

J 46  
Yellow

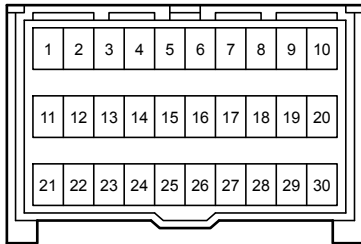

J 78  
White

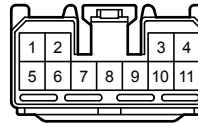

J 79  
White

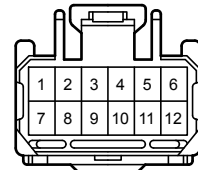

J 80  
White

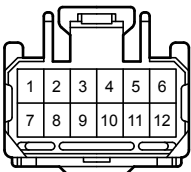

J117  
Black

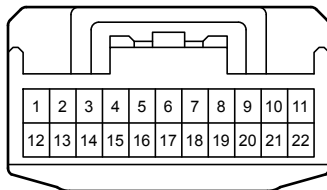

Q 11  
Black

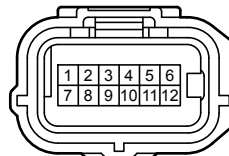

Y 2  
Black

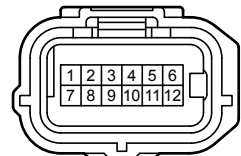

Data Link Connector 3

DD

White

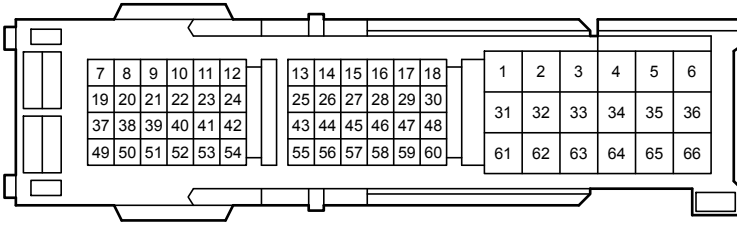

AJ2

White

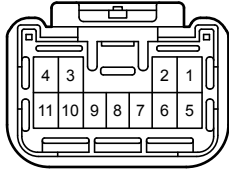
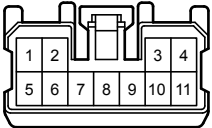

AJ3

White

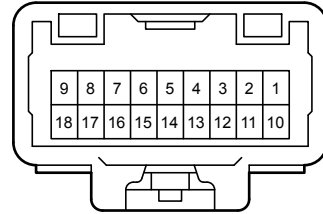
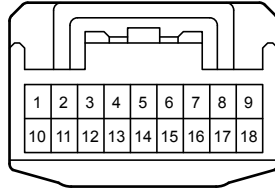

AJ4

White

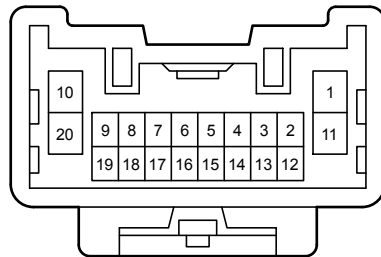
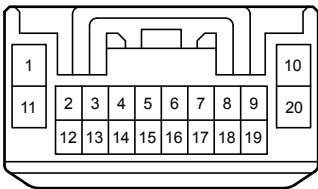

AJ11

Gray

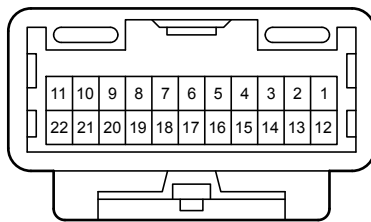
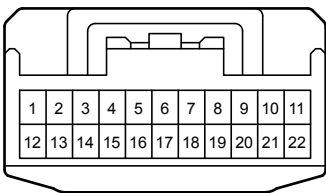

JJ1

White

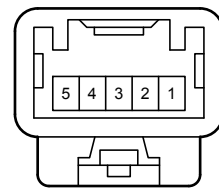
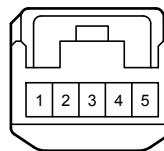

JQ2

Gray

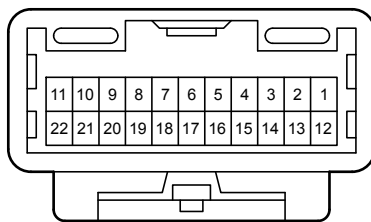
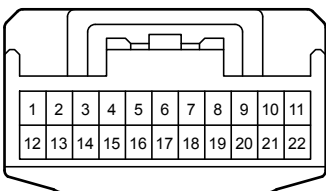

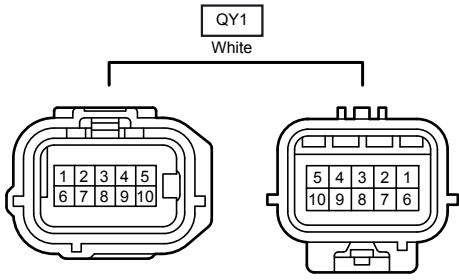



Electronically Controlled Transmission and A/T Indicator <1GR-FE>

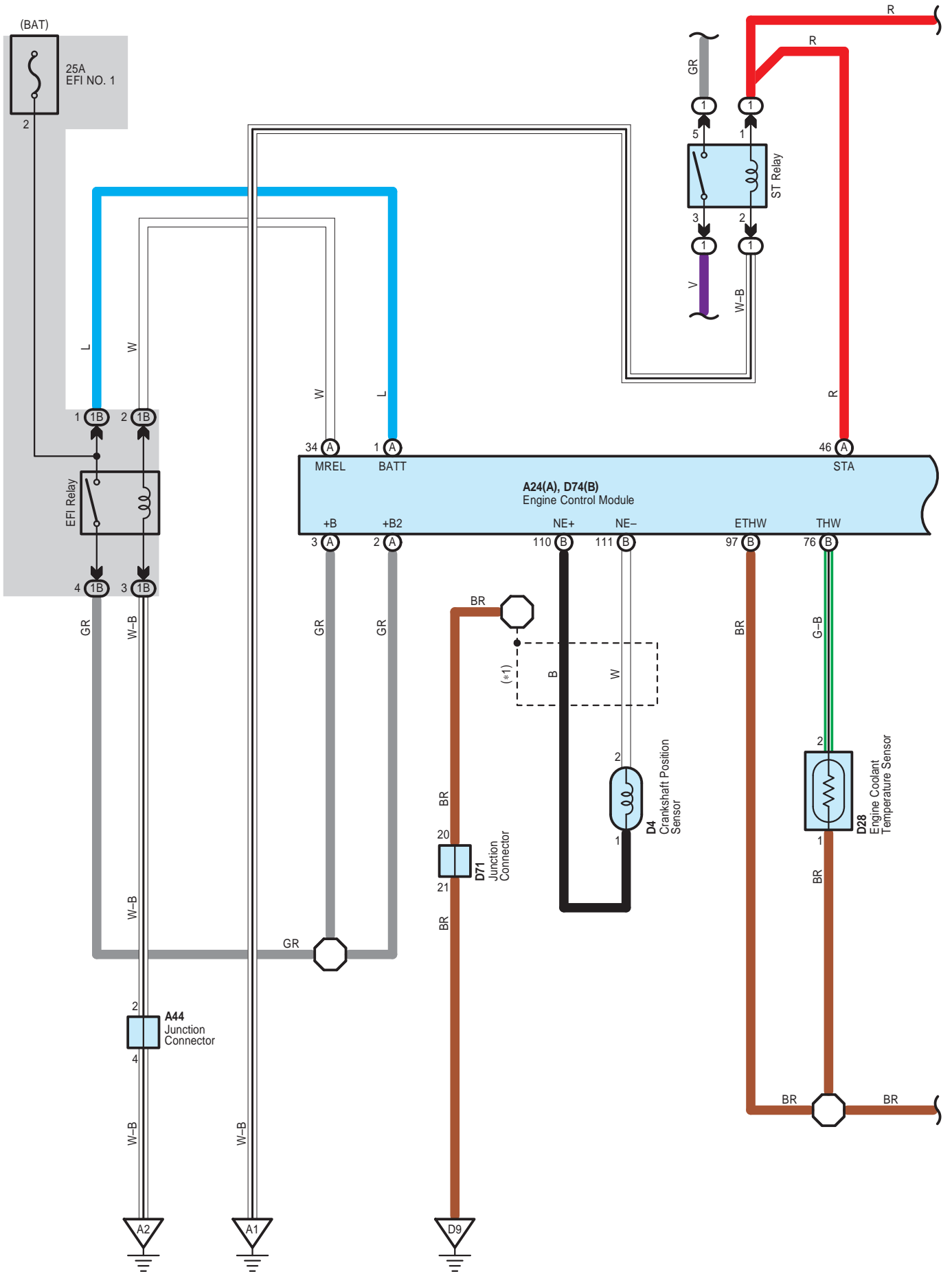

Electronically Controlled Transmission and A/T Indicator <1GR-FE>

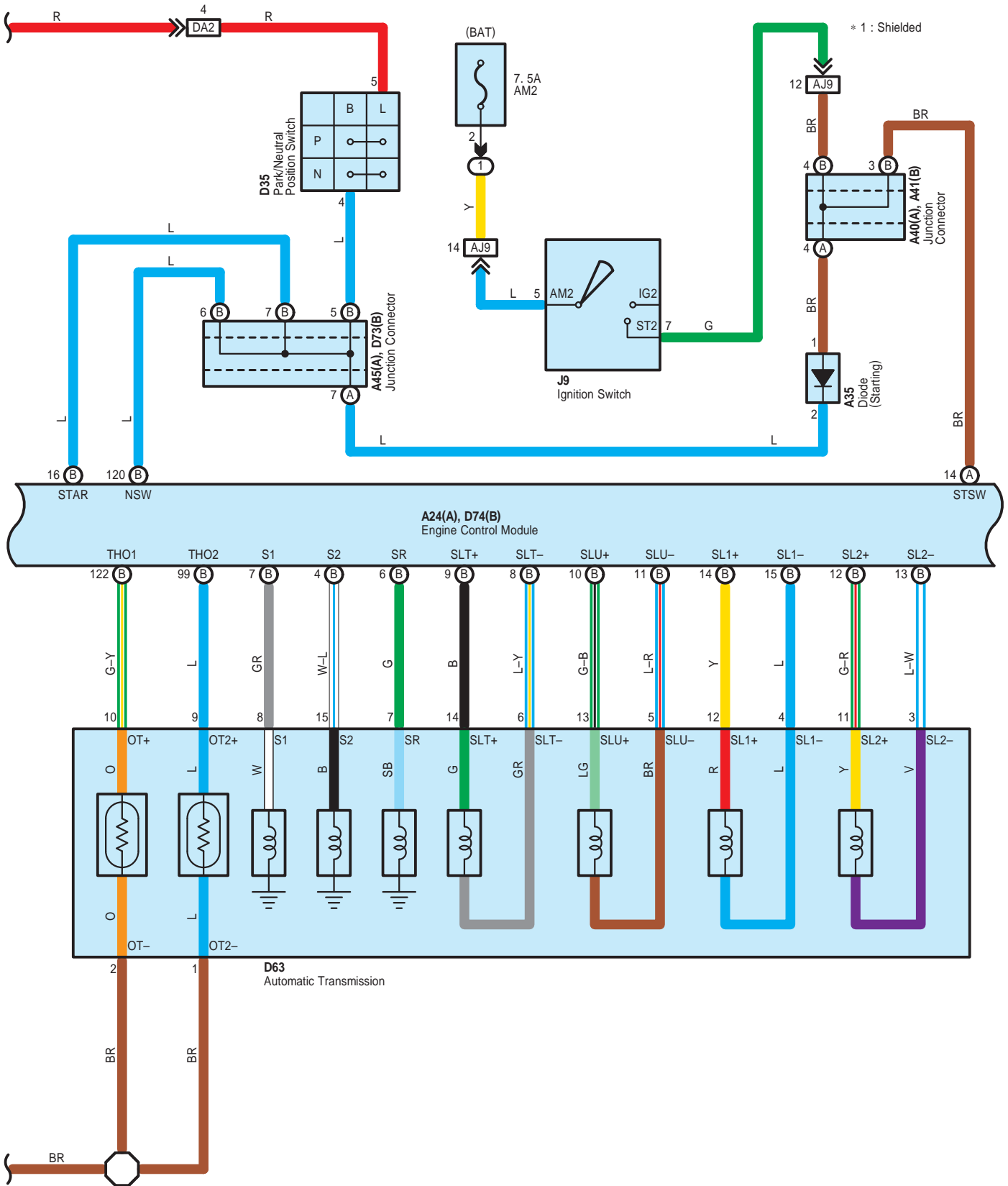

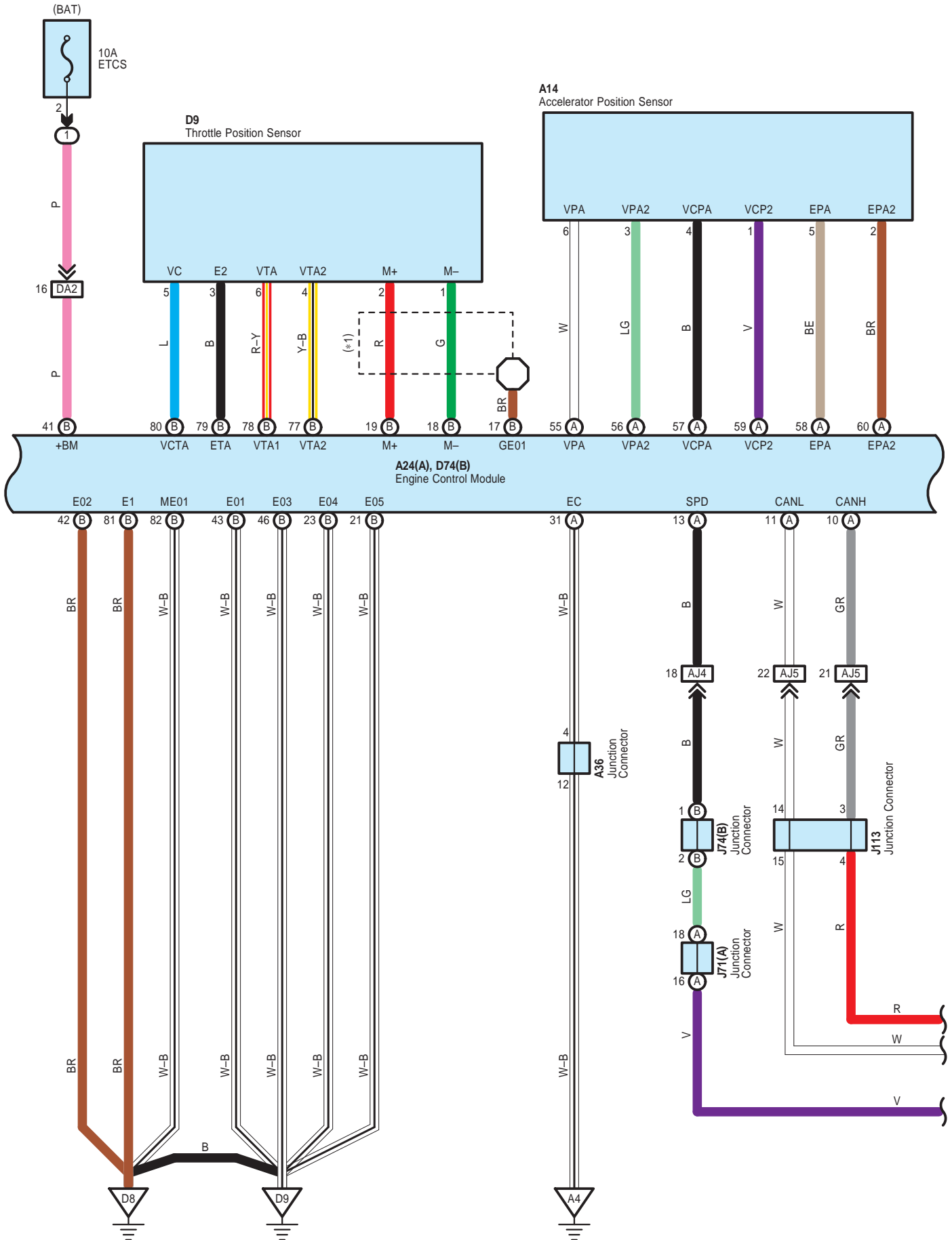



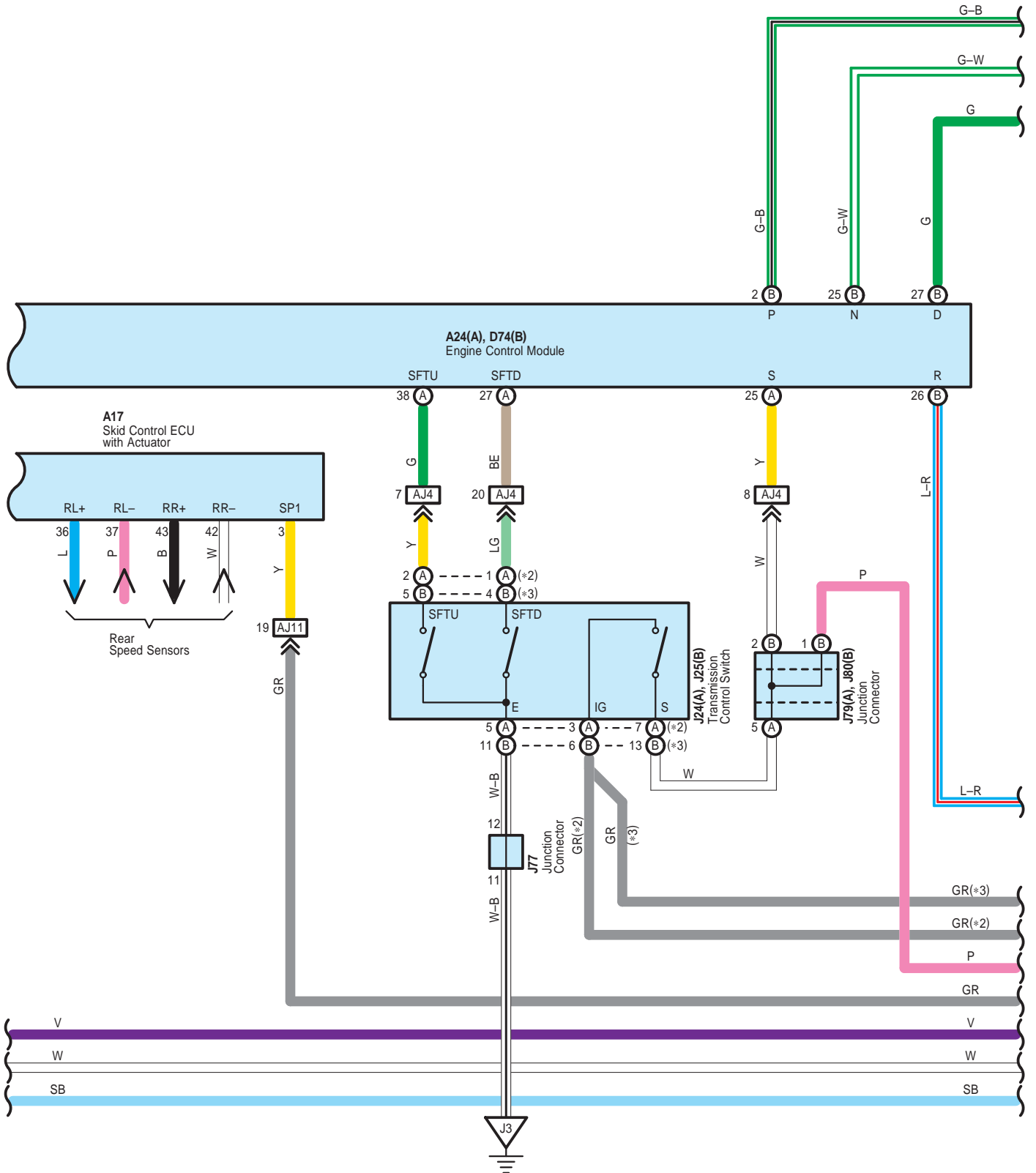

Electronically Controlled Transmission and A/T Indicator <1GR-FE>

- \* 2 : Floor Shift
- \* 3 : Column Shift

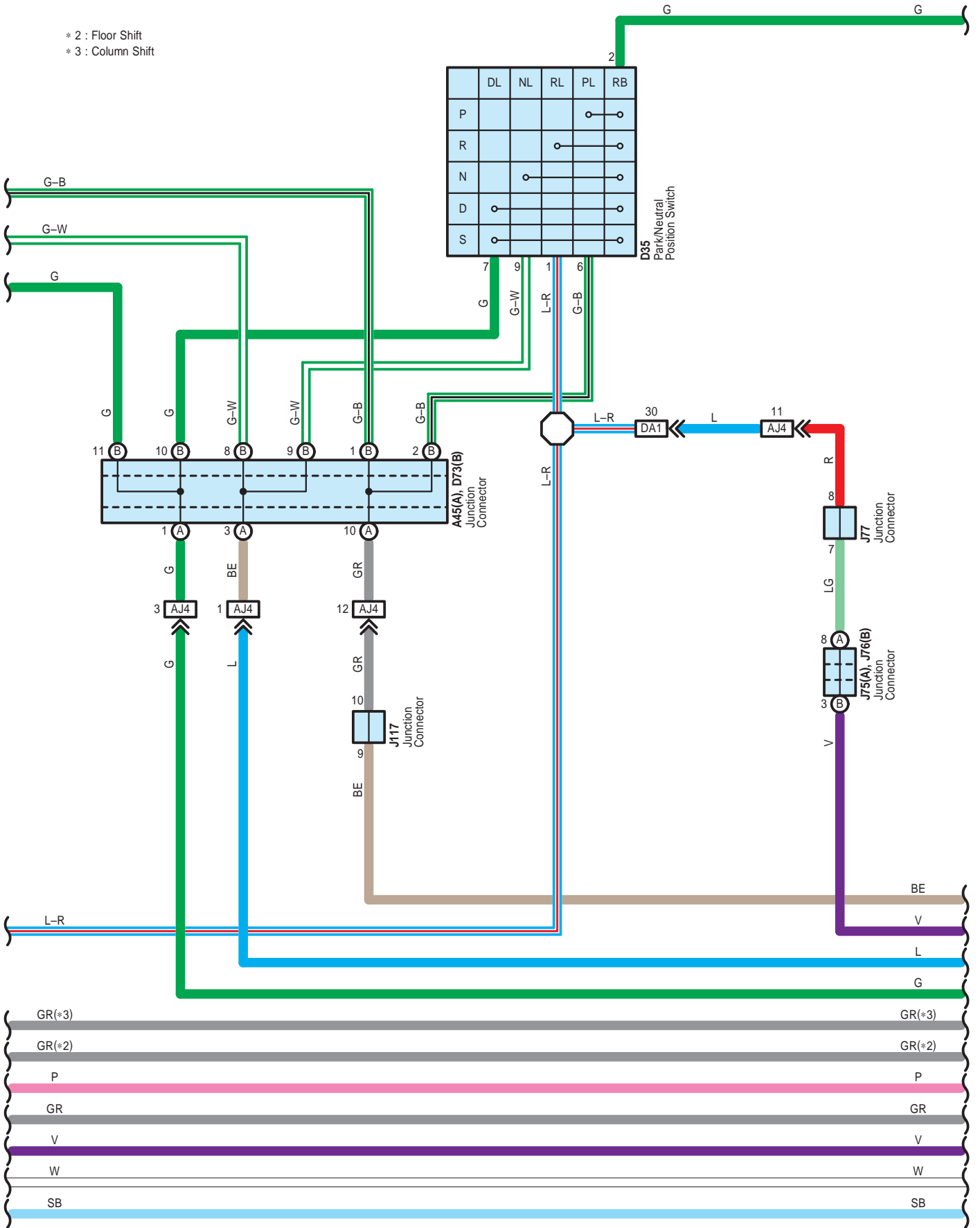

Electronically Controlled Transmission and A/T Indicator <1GR-FE>

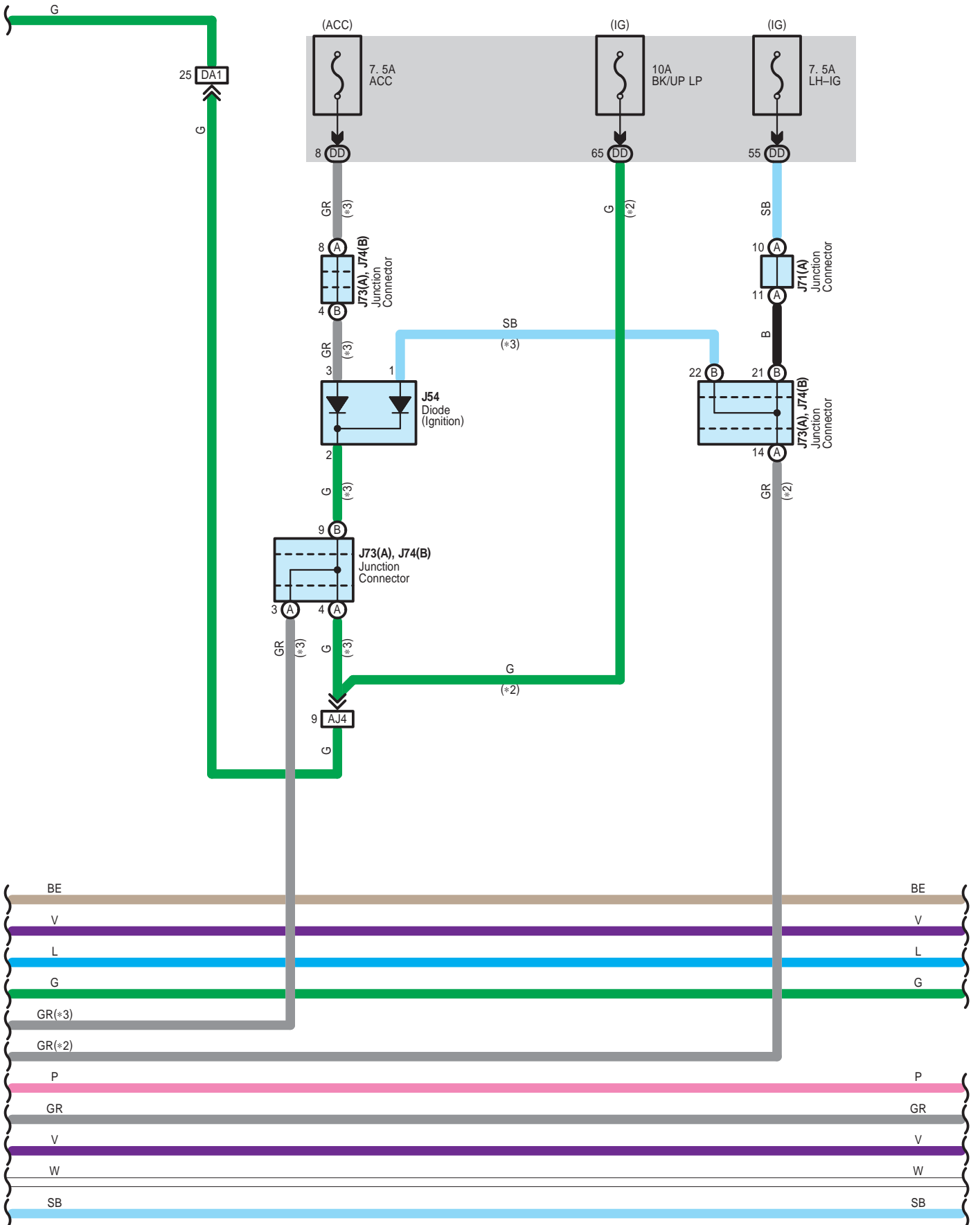

Electronically Controlled Transmission and A/T Indicator <1GR-FE>

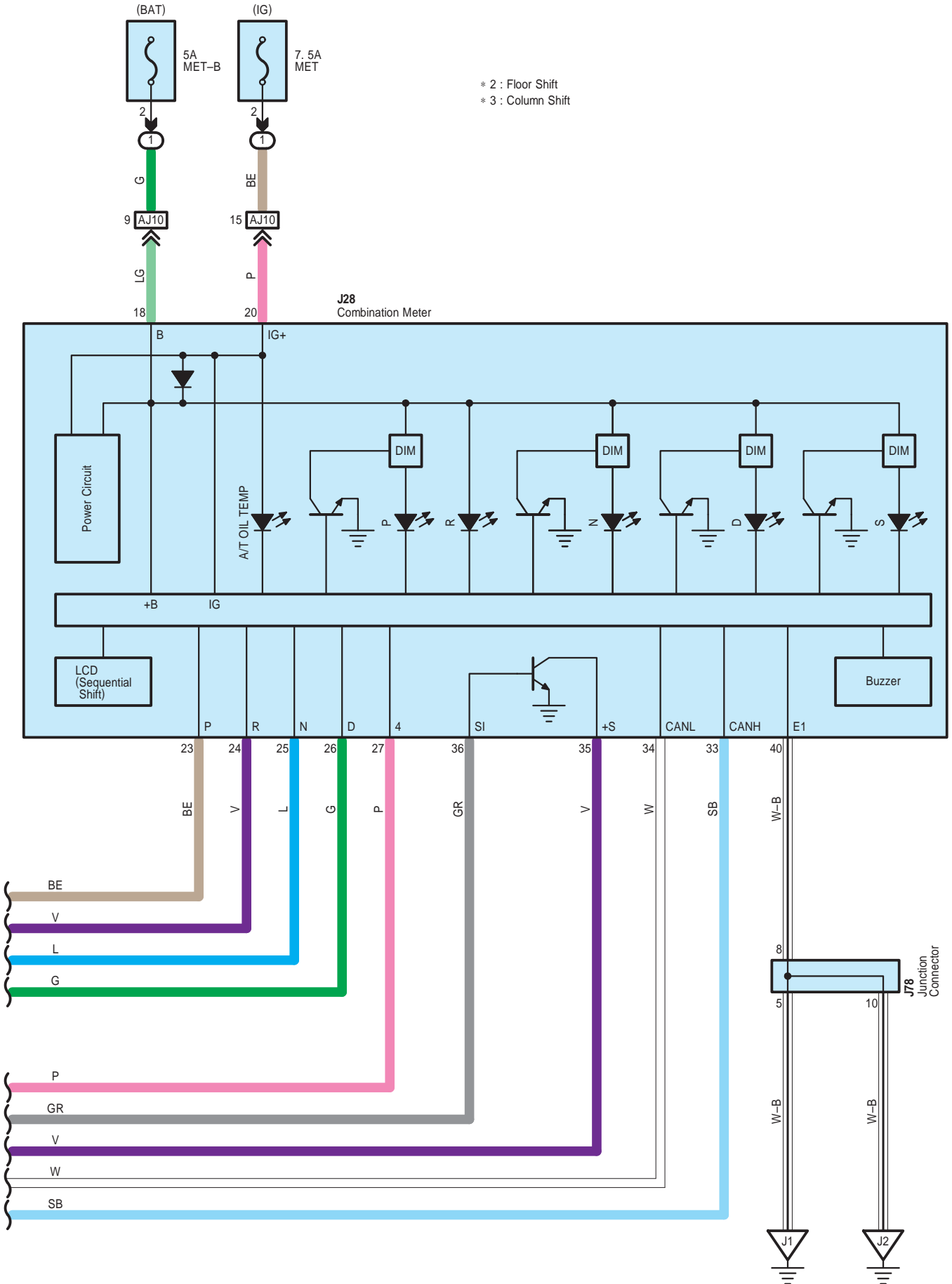



Electronically Controlled Transmission and A/T Indicator <1GR-FE>

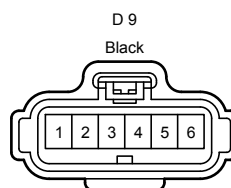
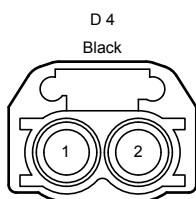
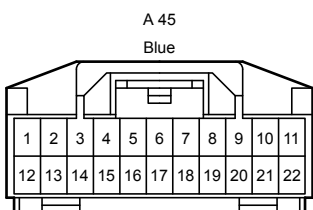
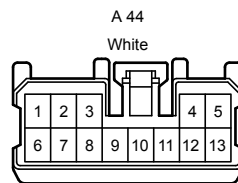
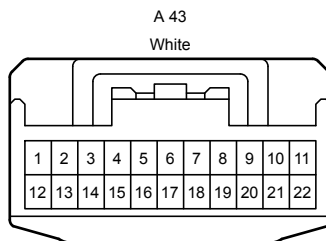
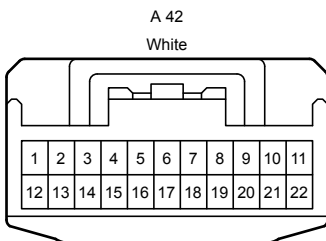
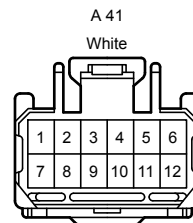
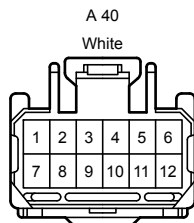
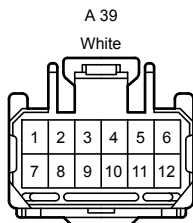
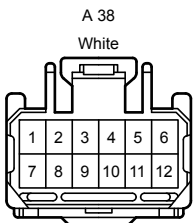
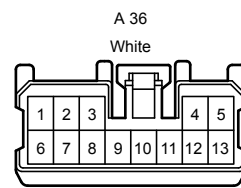
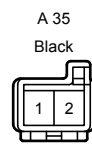
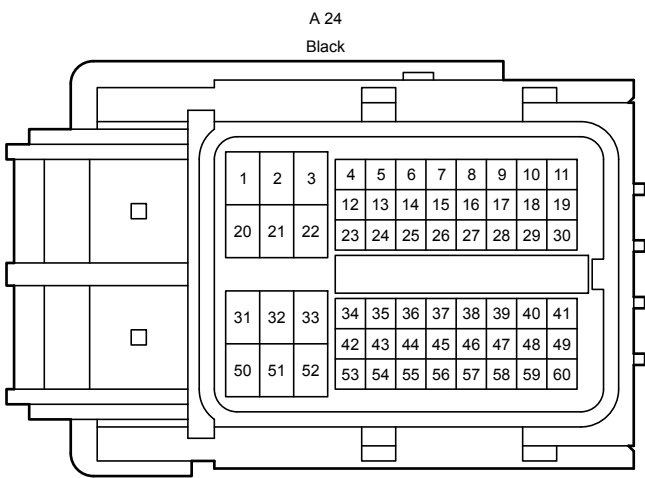
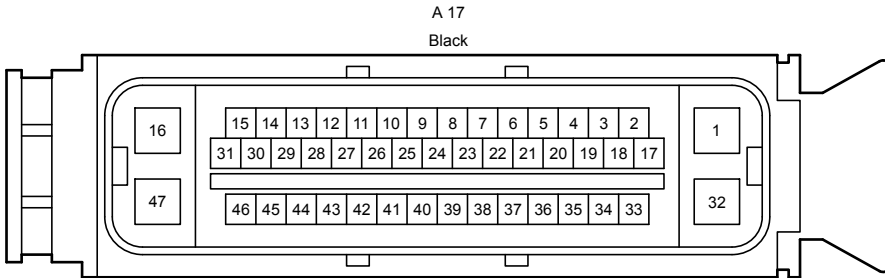
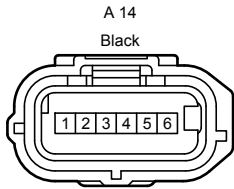
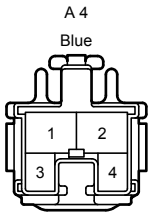

Electronically Controlled Transmission and A/T Indicator <1GR-FE>

D 35  
Gray

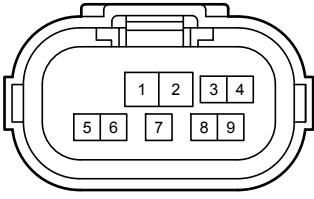

D 63  
Gray

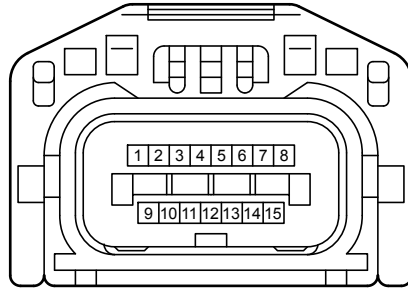

D 65  
Black

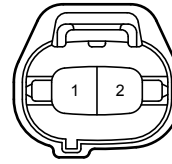

D 66  
Black

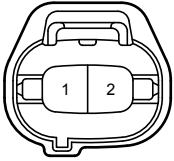

D 71  
White

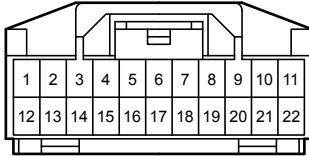

D 73  
Blue

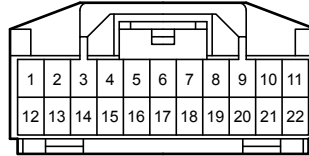

D 74  
Black

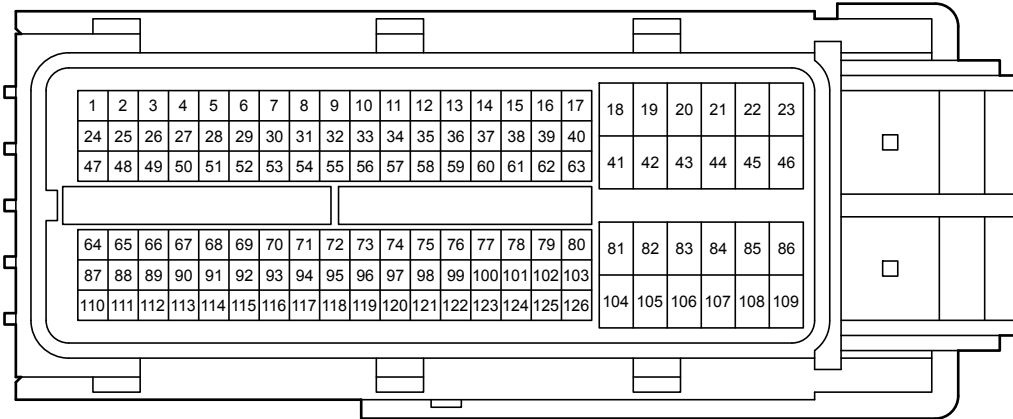

J 9  
White

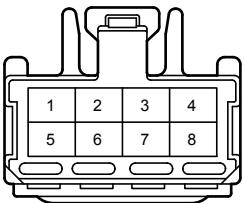

J 17  
White

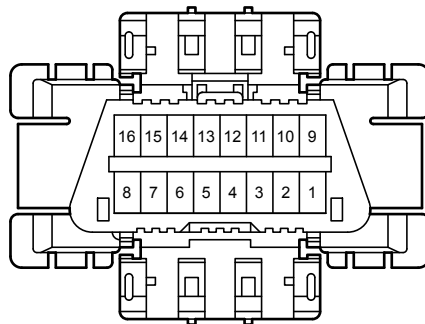

J 24  
White

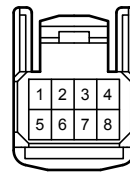

J 25  
White

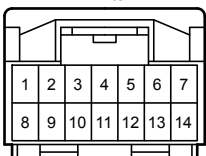

J 28  
White

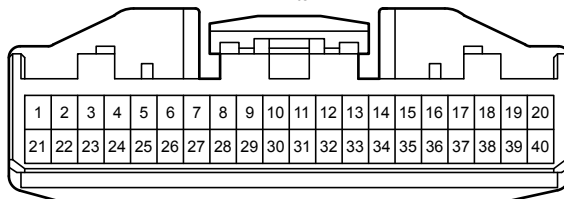

J 54  
Orange



Electronically Controlled Transmission and A/T Indicator <1GR-FE>

J 71  
Black

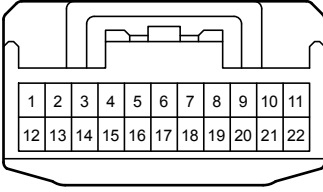

J 73  
Black

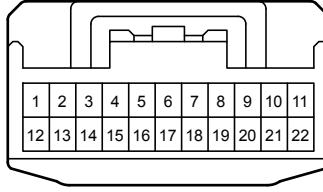

J 74  
Black

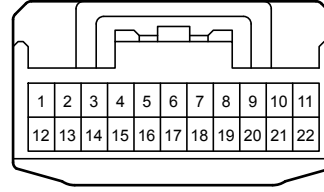

J 75  
White

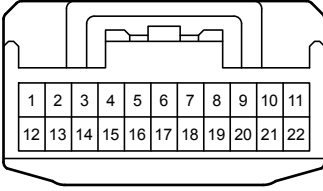

J 76  
White

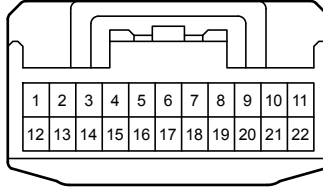

J 77  
Gray

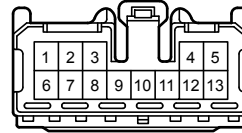

J 78  
White

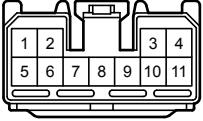

J 79  
White

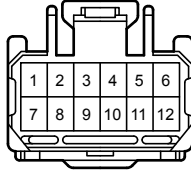

J 80  
White

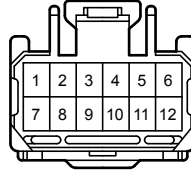

J113  
Gray

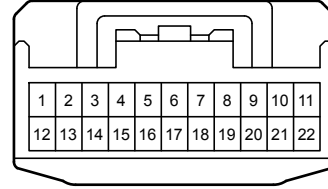

J117  
Black

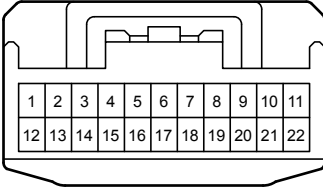

J118  
Gray

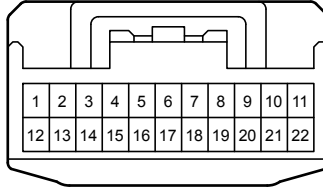

1B  
White

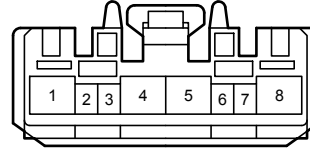

DD  
White

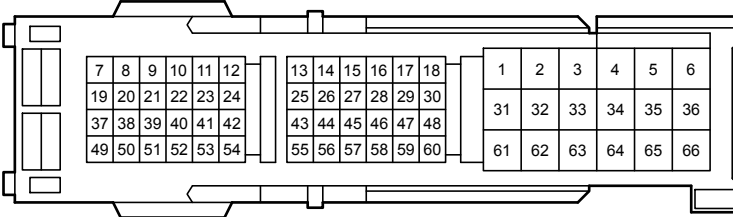

AJ4  
White

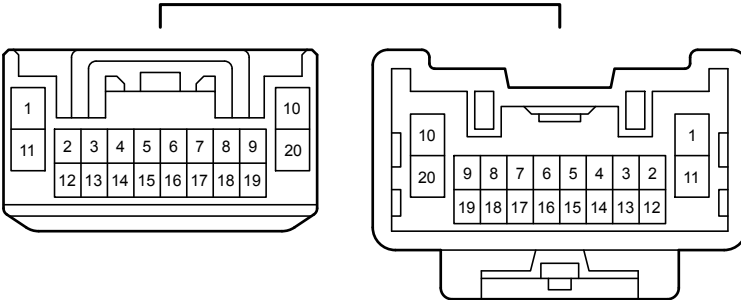

AJ5  
White

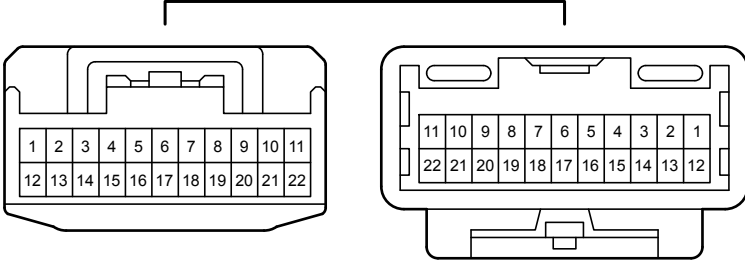

AJ9  
Gray

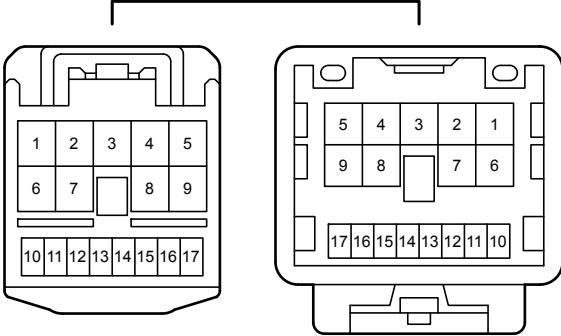

AJ10  
Gray

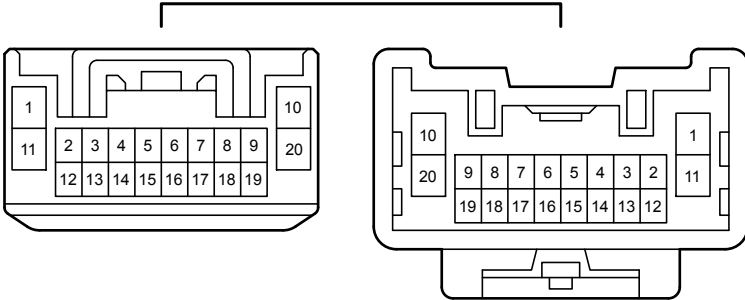

AJ11  
Gray

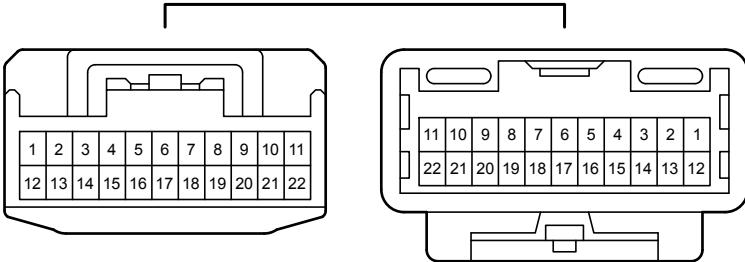

DA1  
White

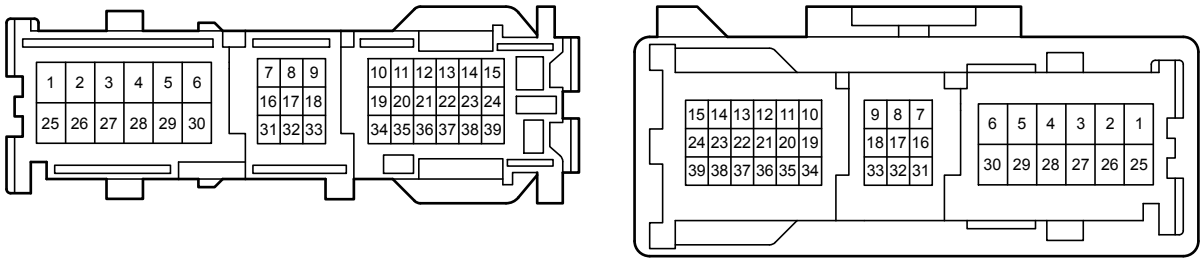

DA2  
White

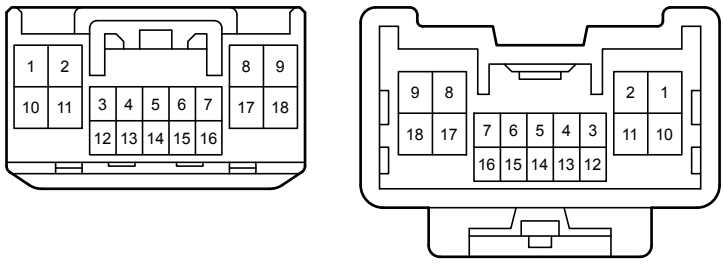



Electronically Controlled Transmission and A/T Indicator <1UR-FE>

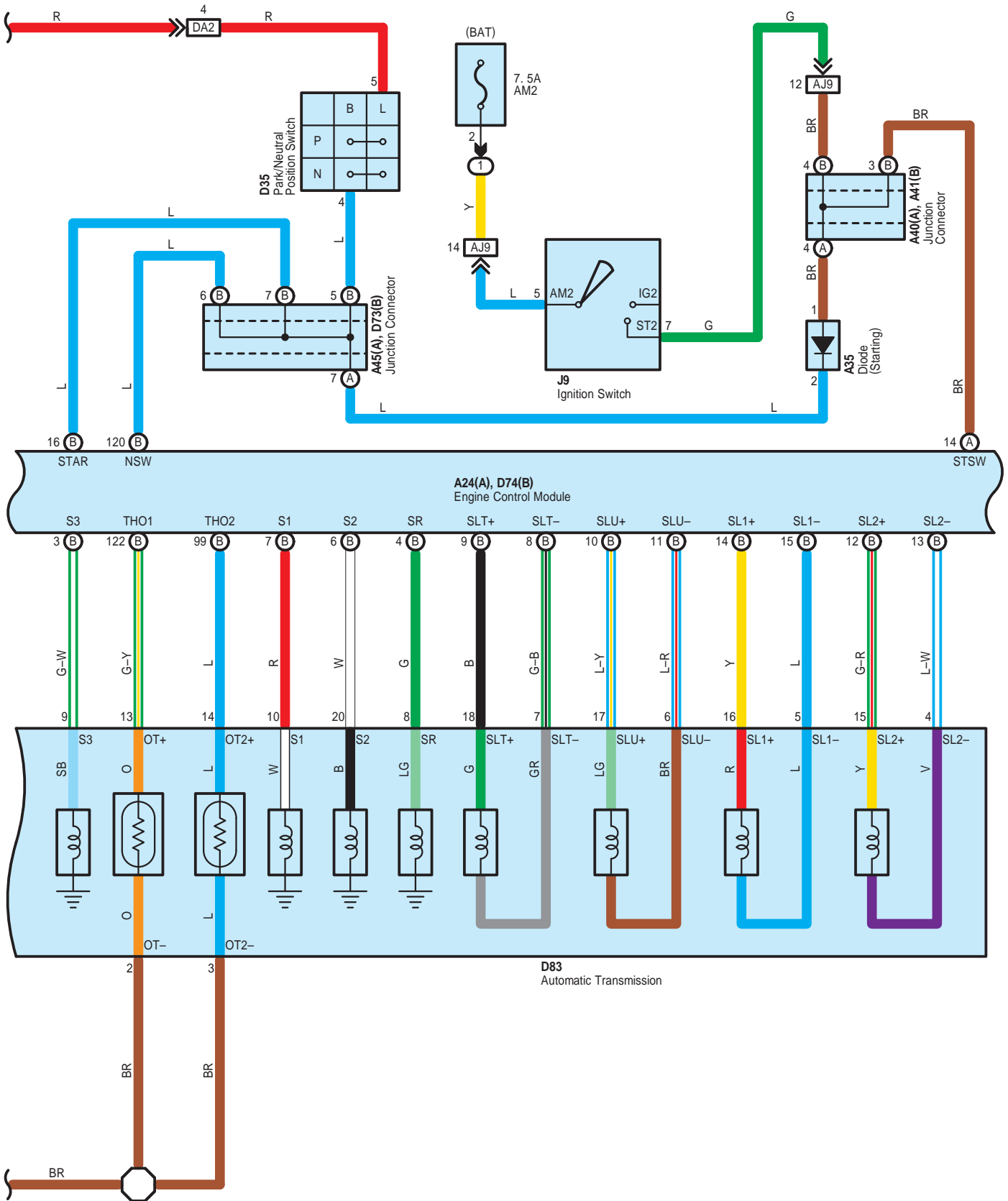





Electronically Controlled Transmission and A/T Indicator <1UR-FE>

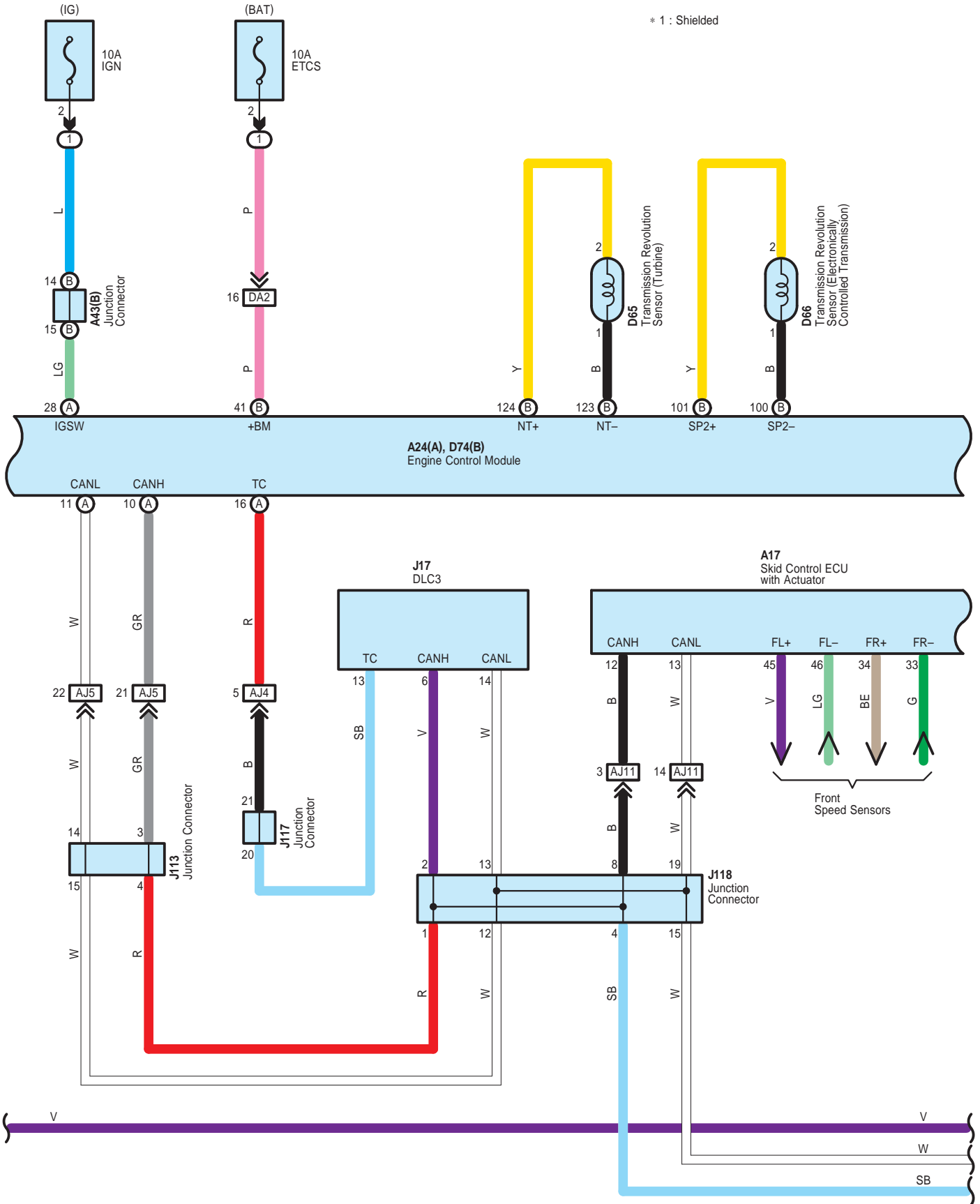

Electronically Controlled Transmission and A/T Indicator <1UR-FE>

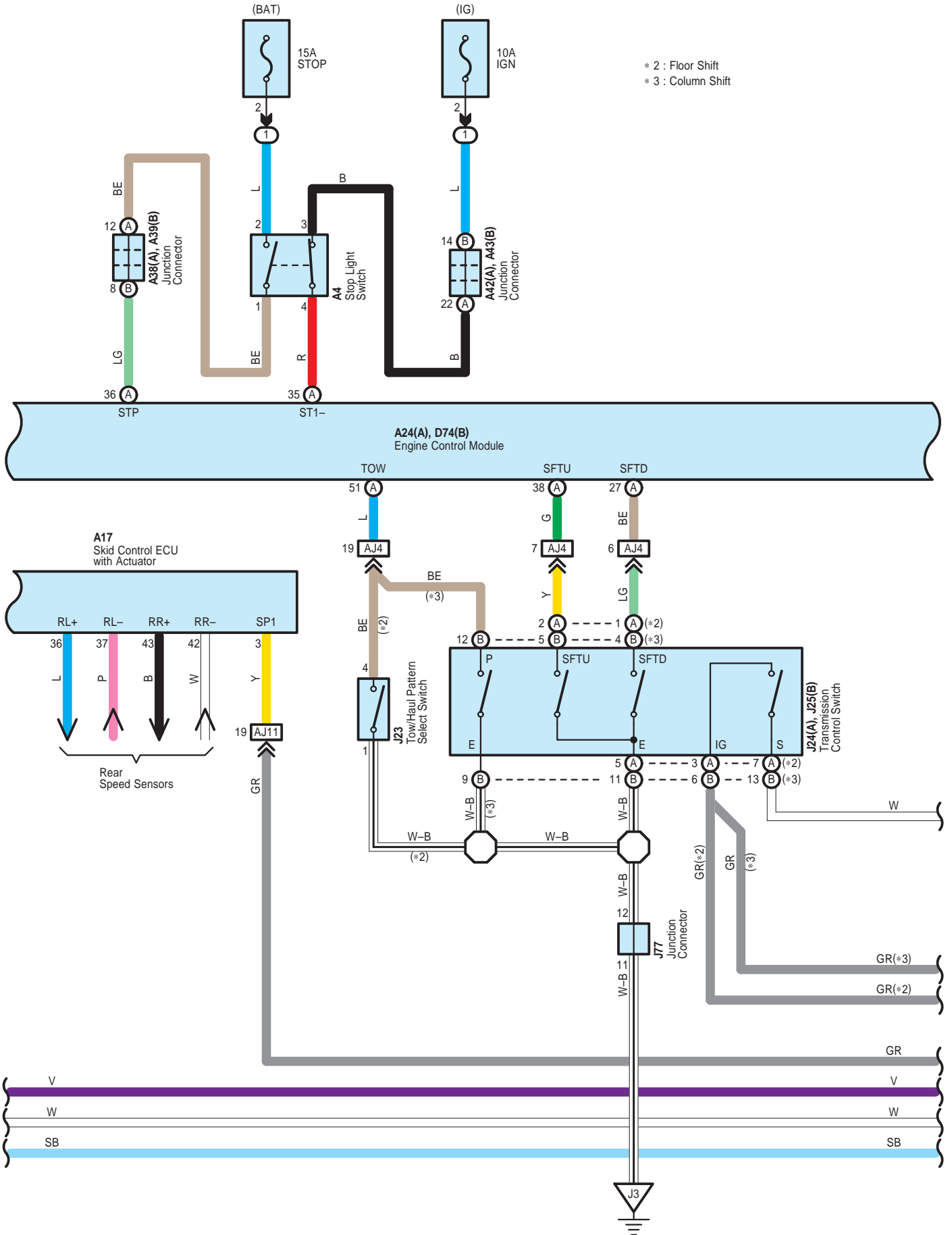

Electronically Controlled Transmission and A/T Indicator <1UR-FE>

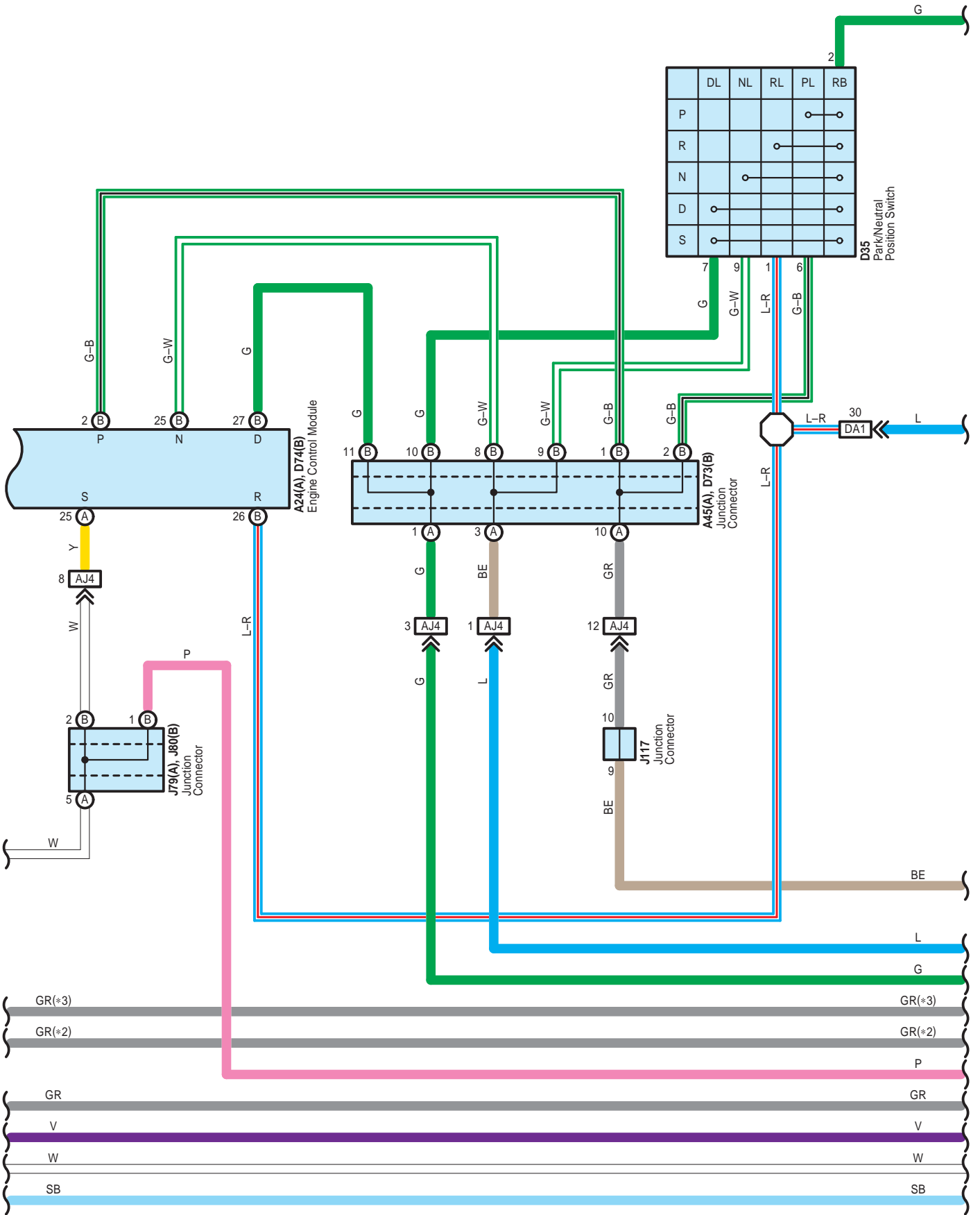

Electronically Controlled Transmission and A/T Indicator <1UR-FE>

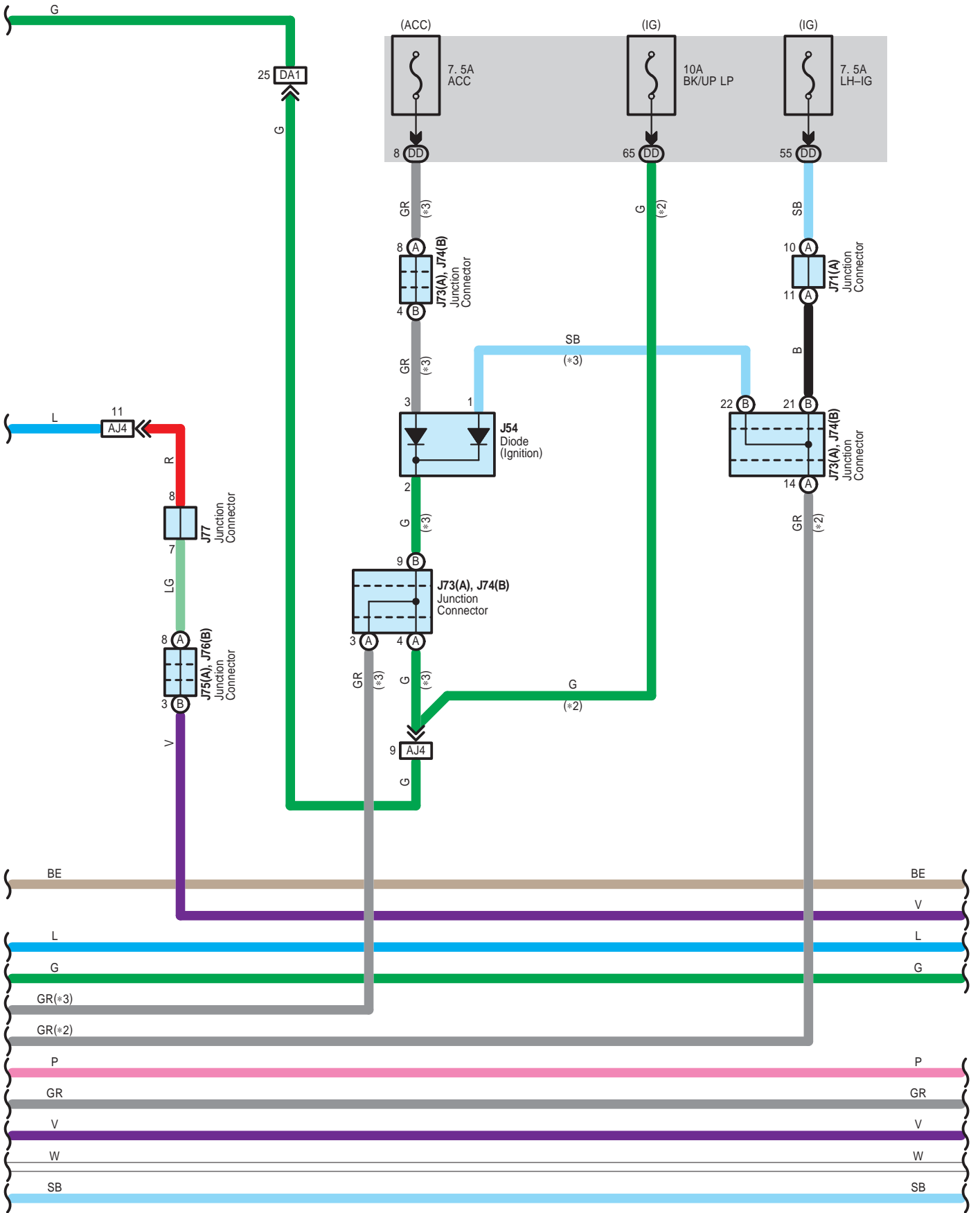

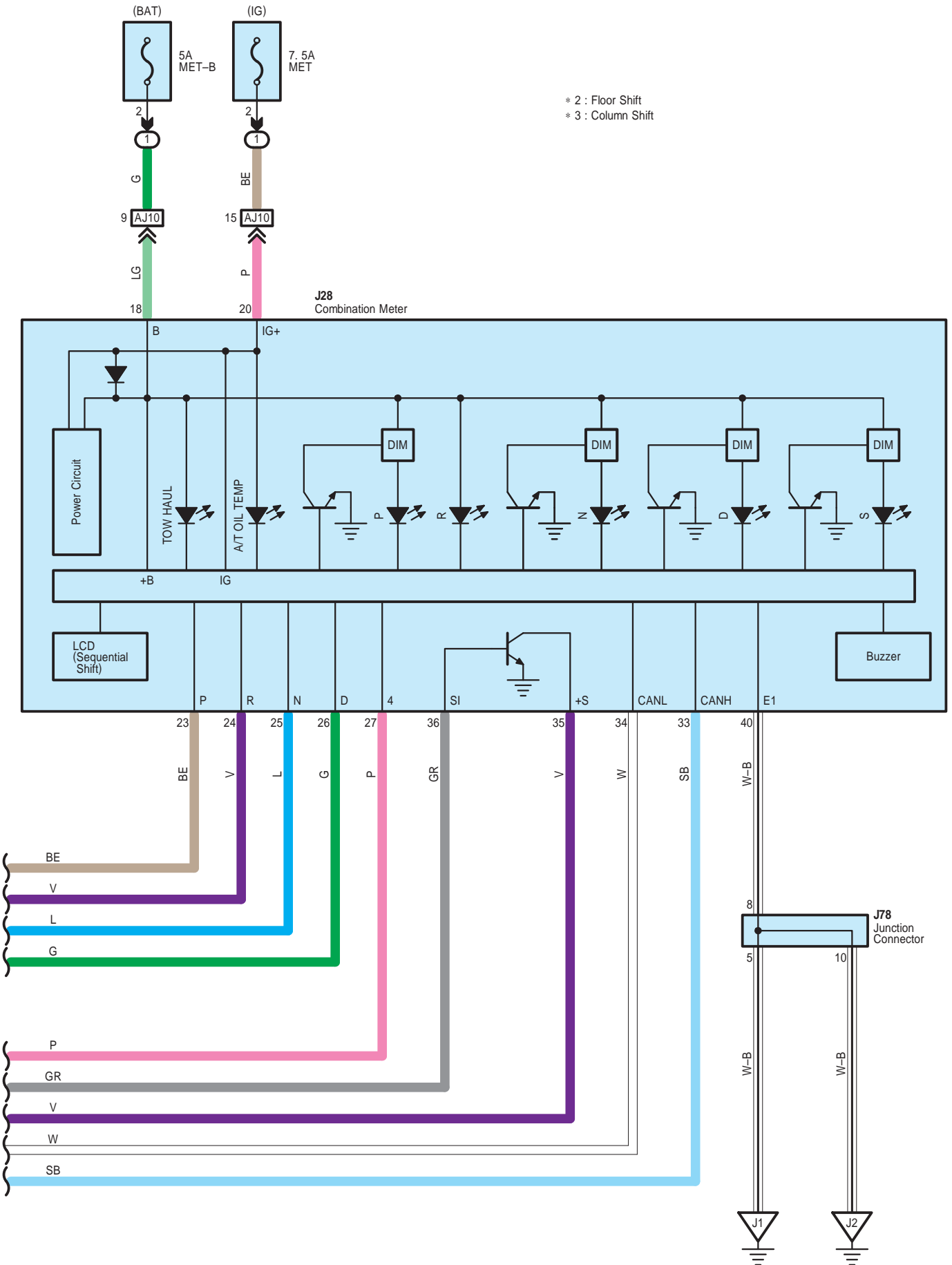

Electronically Controlled Transmission and A/T Indicator <1UR-FE>

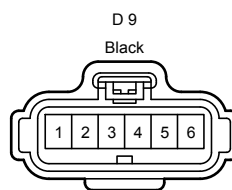
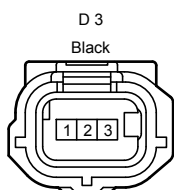
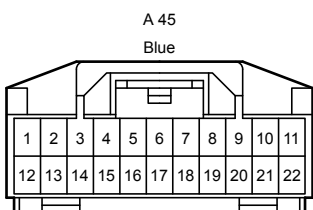
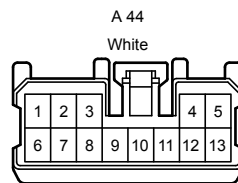
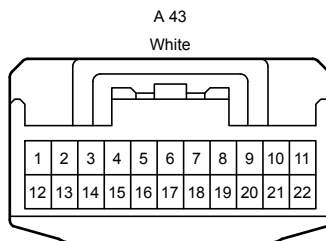
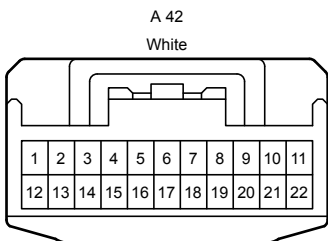
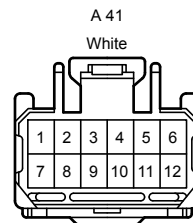
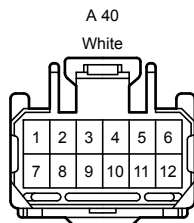
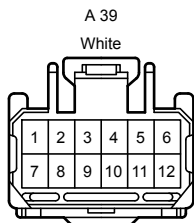
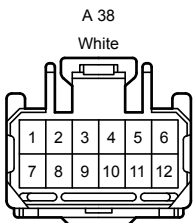
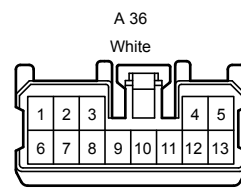
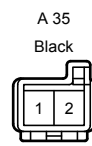
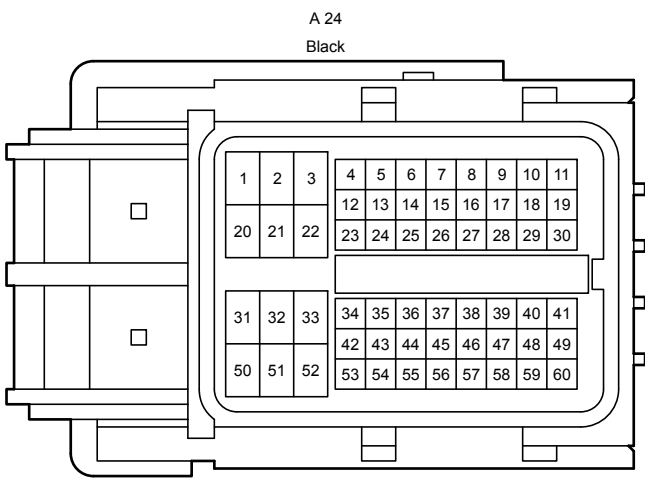
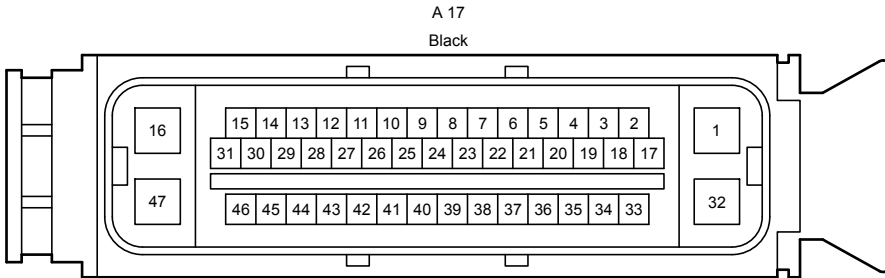
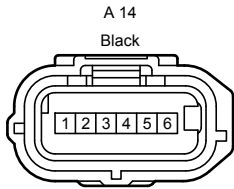
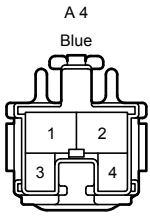

Electronically Controlled Transmission and A/T Indicator <1UR-FE>

D 35  
Gray

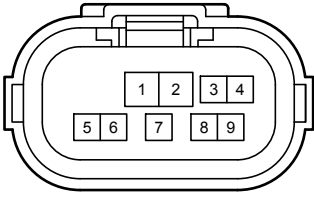

D 65  
Black

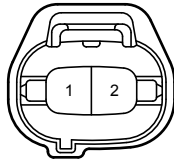

D 66  
Black

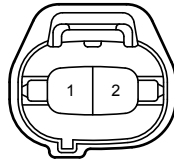

D 73  
Blue

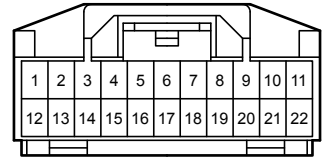

D 74  
Black

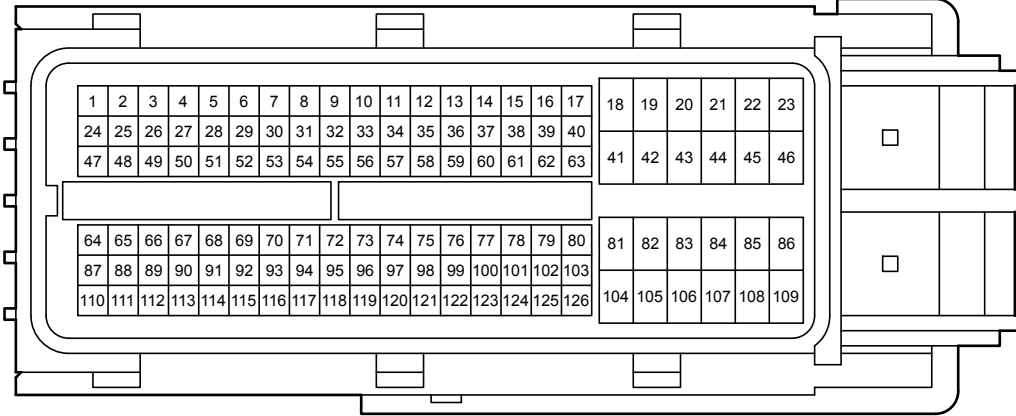

D 83  
Gray

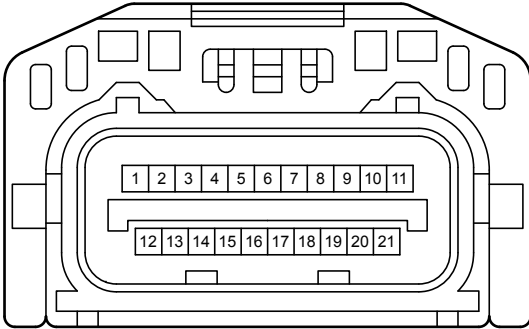

J 9  
White

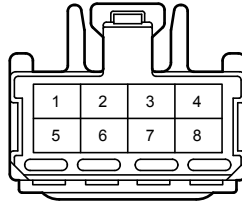

J 17  
White

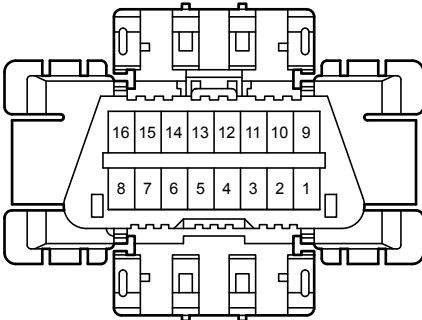

J 23  
Black

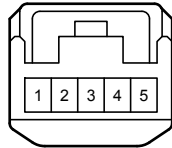

J 24  
White

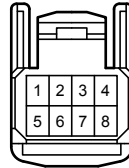

J 25  
White

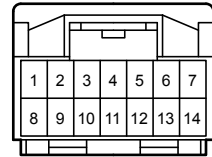

Electronically Controlled Transmission and A/T Indicator <1UR-FE>

J 28  
White

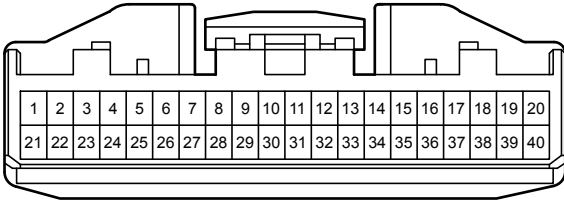

J 54  
Orange

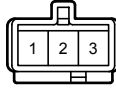

J 71  
Black

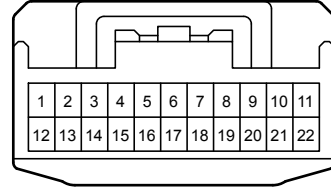

J 73  
Black

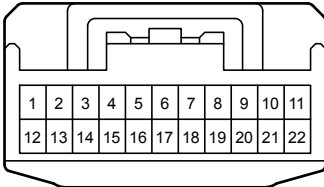

J 74  
Black

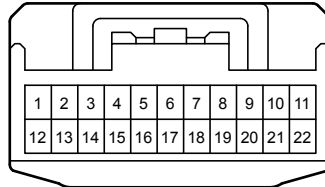

J 75  
White

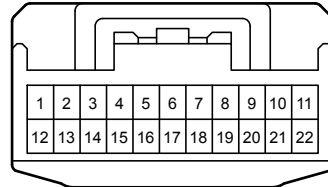

J 76  
White

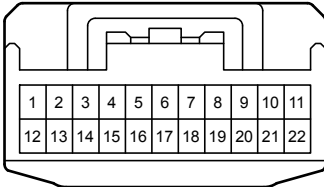

J 77  
Gray

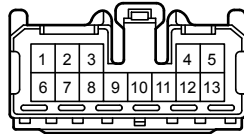

J 78  
White

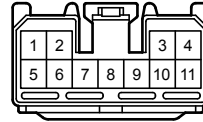

J 79  
White

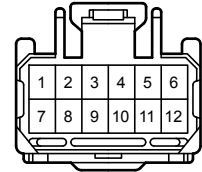

J 80  
White

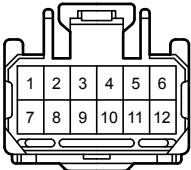

J113  
Gray

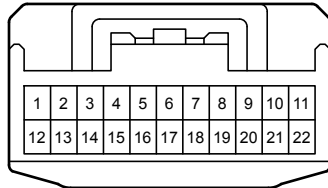

J117  
Black

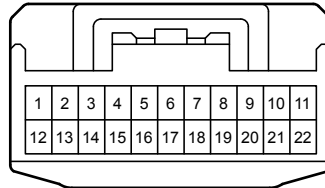

J118  
Gray

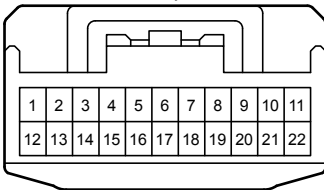

1B  
White

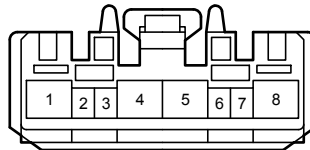

DD  
White

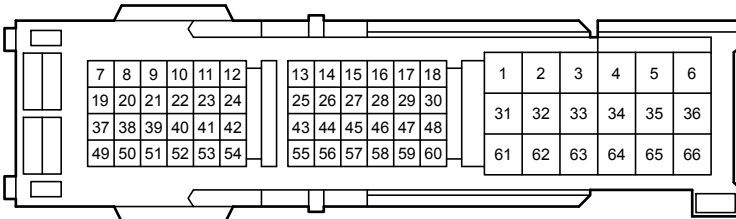



AJ4  
White

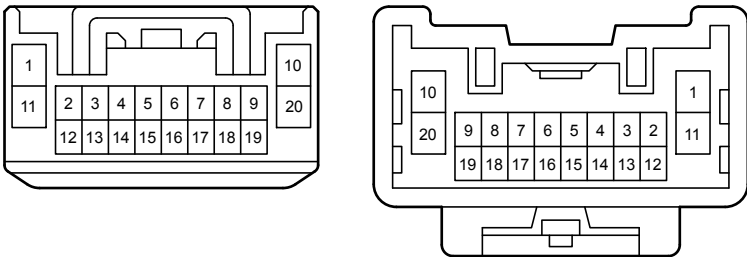

AJ5  
White

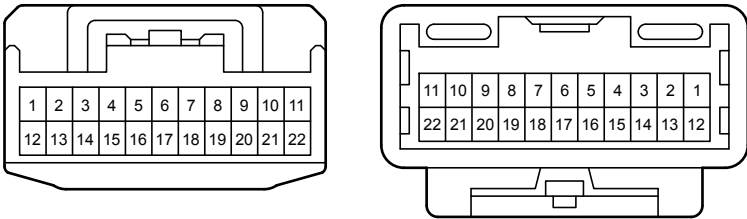

AJ9  
Gray

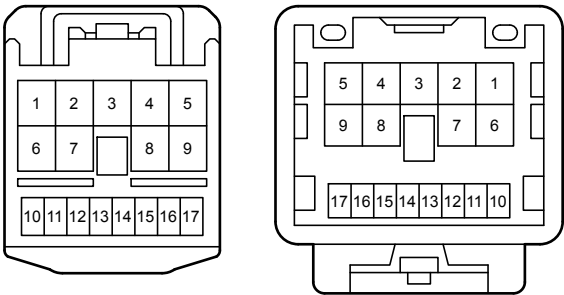

AJ10  
Gray

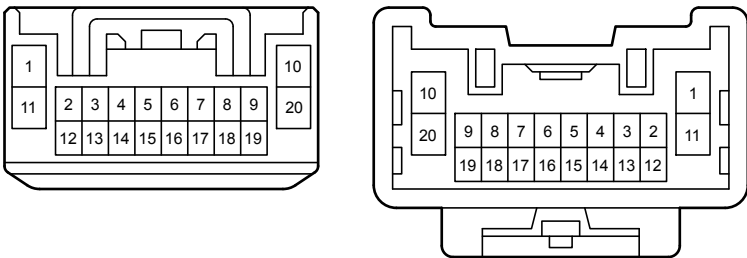



Electronically Controlled Transmission and A/T Indicator <3UR-FE, 3UR-FBE>

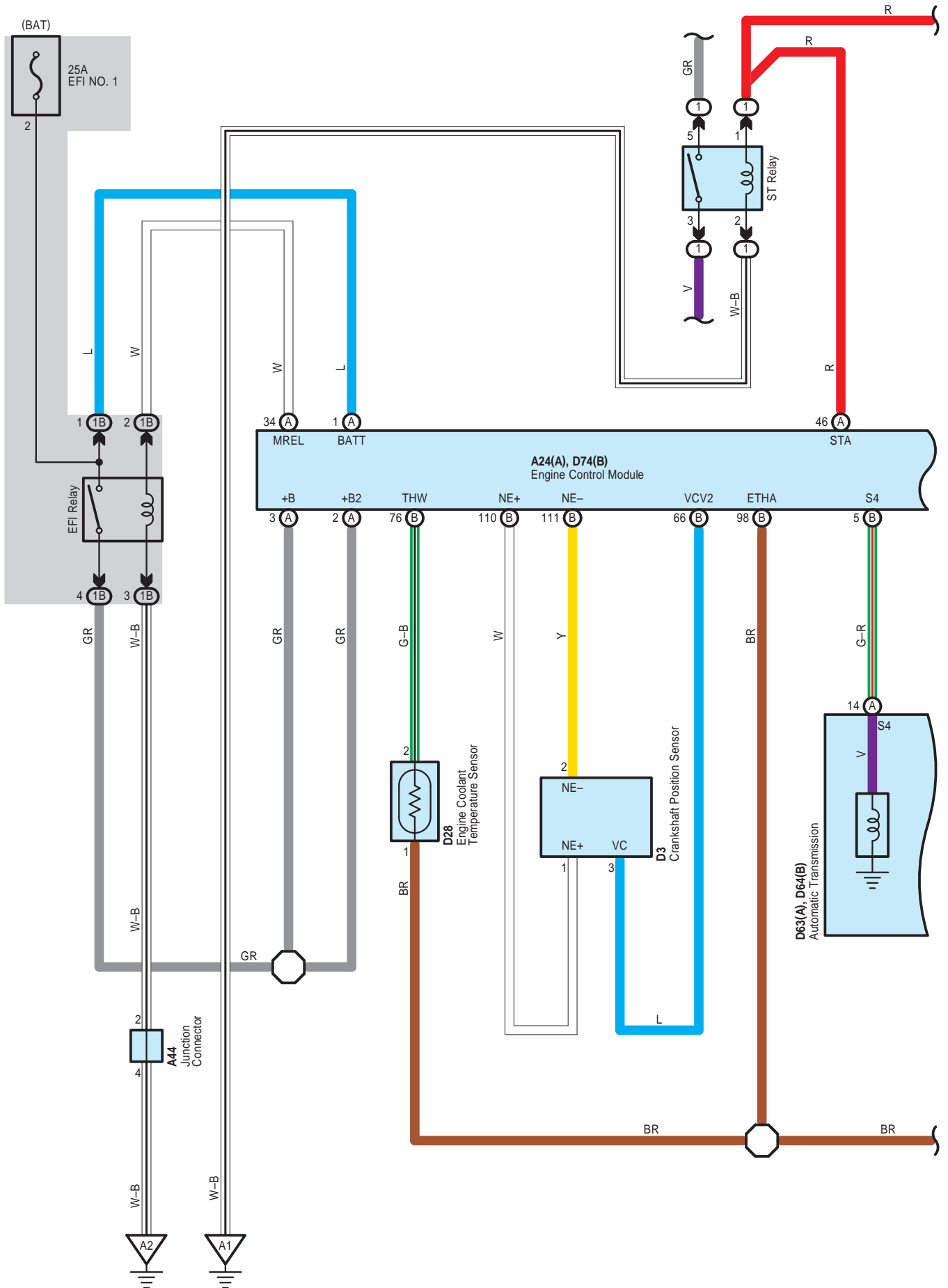

Electronically Controlled Transmission and A/T Indicator <3UR-FE, 3UR-FBE>

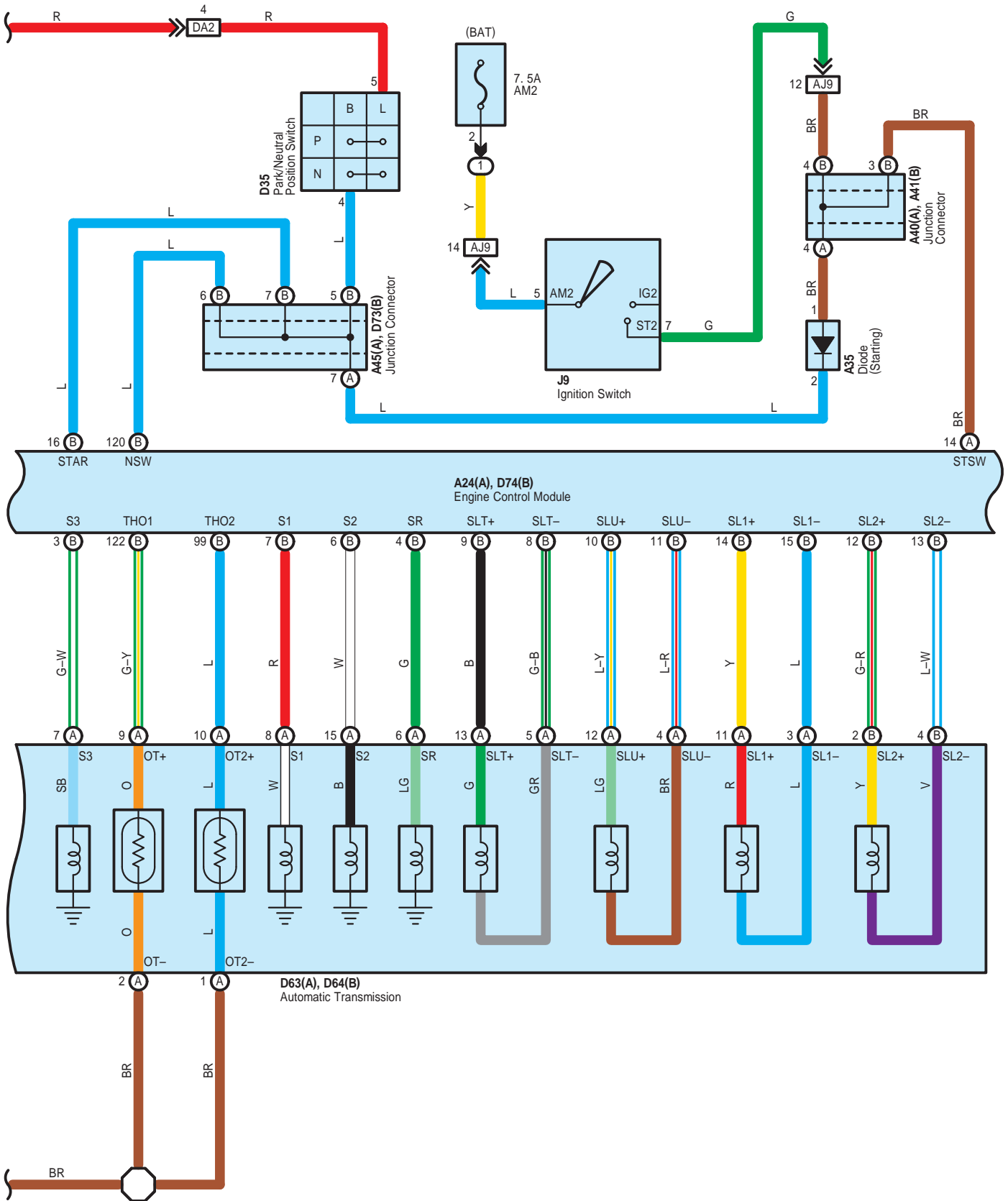

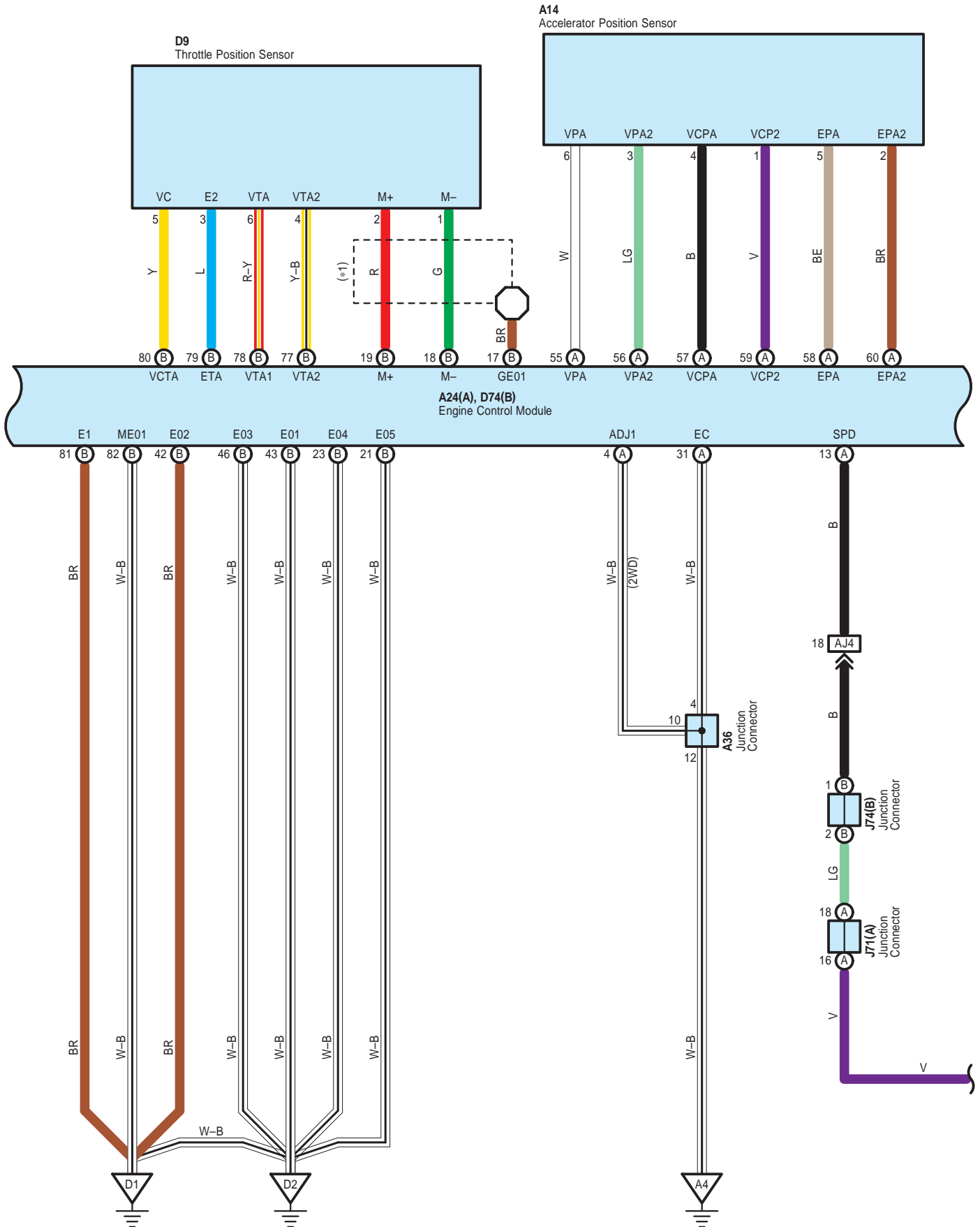

Electronically Controlled Transmission and A/T Indicator <3UR-FE, 3UR-FBE>

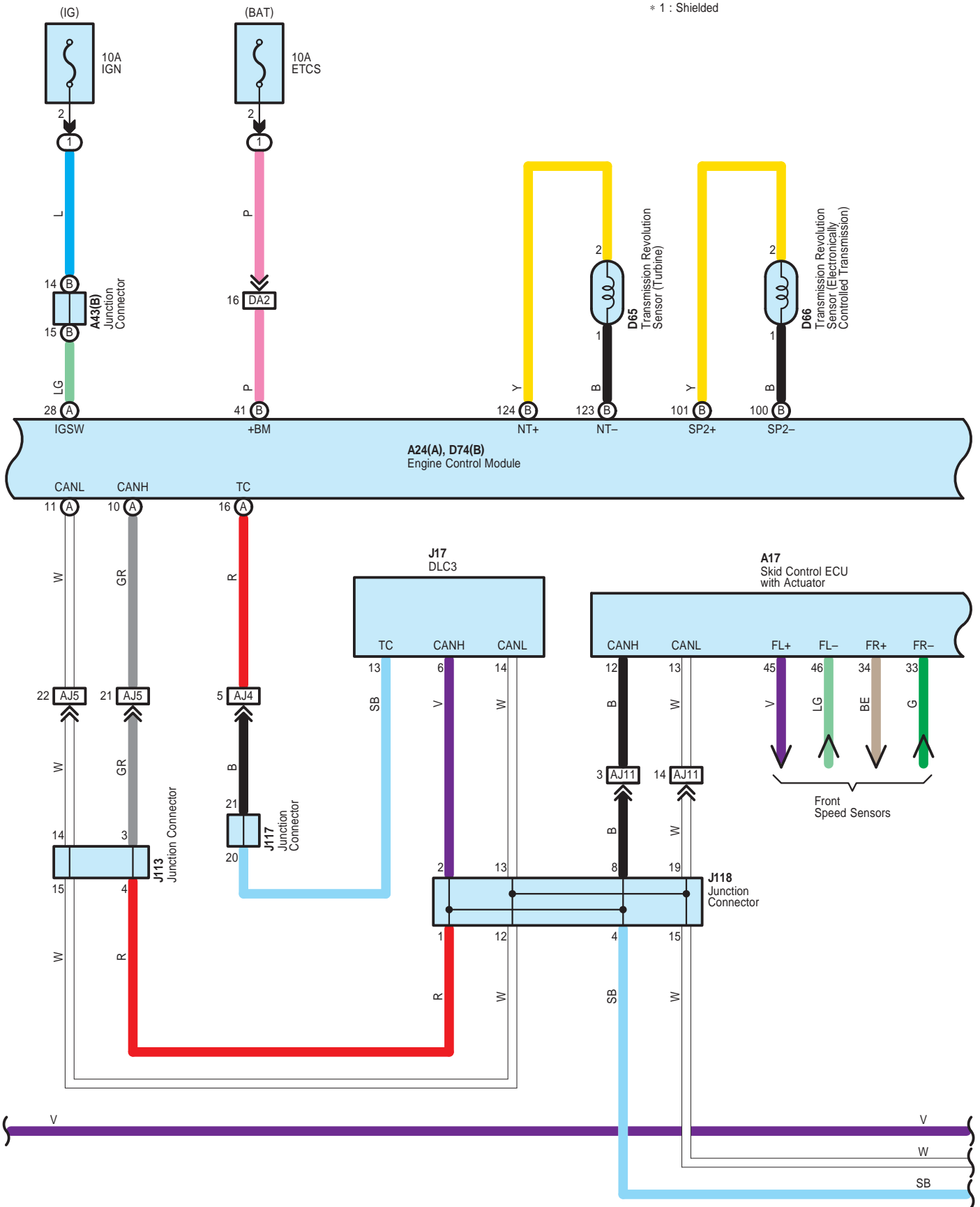



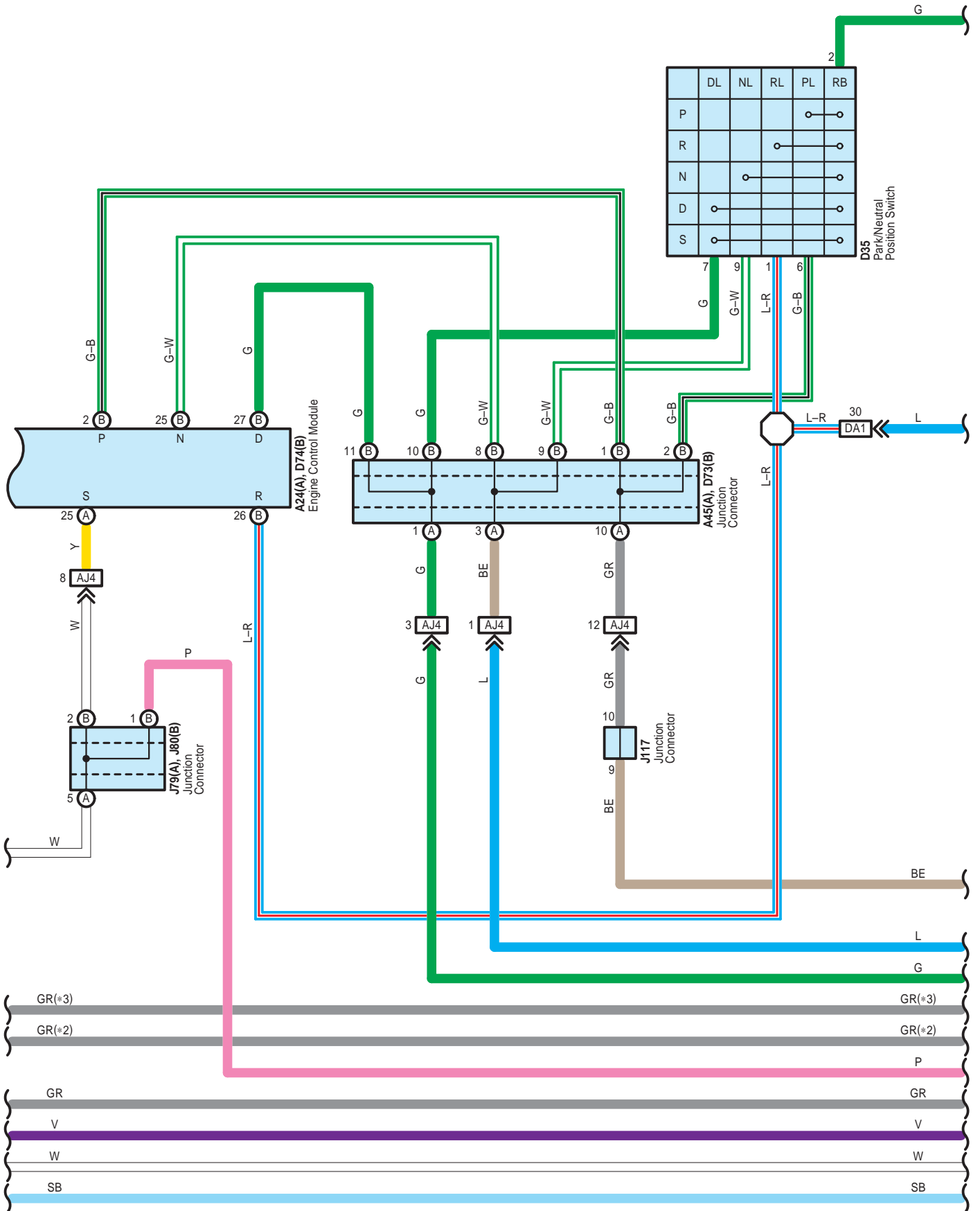



Electronically Controlled Transmission and A/T Indicator <3UR-FE, 3UR-FBE>

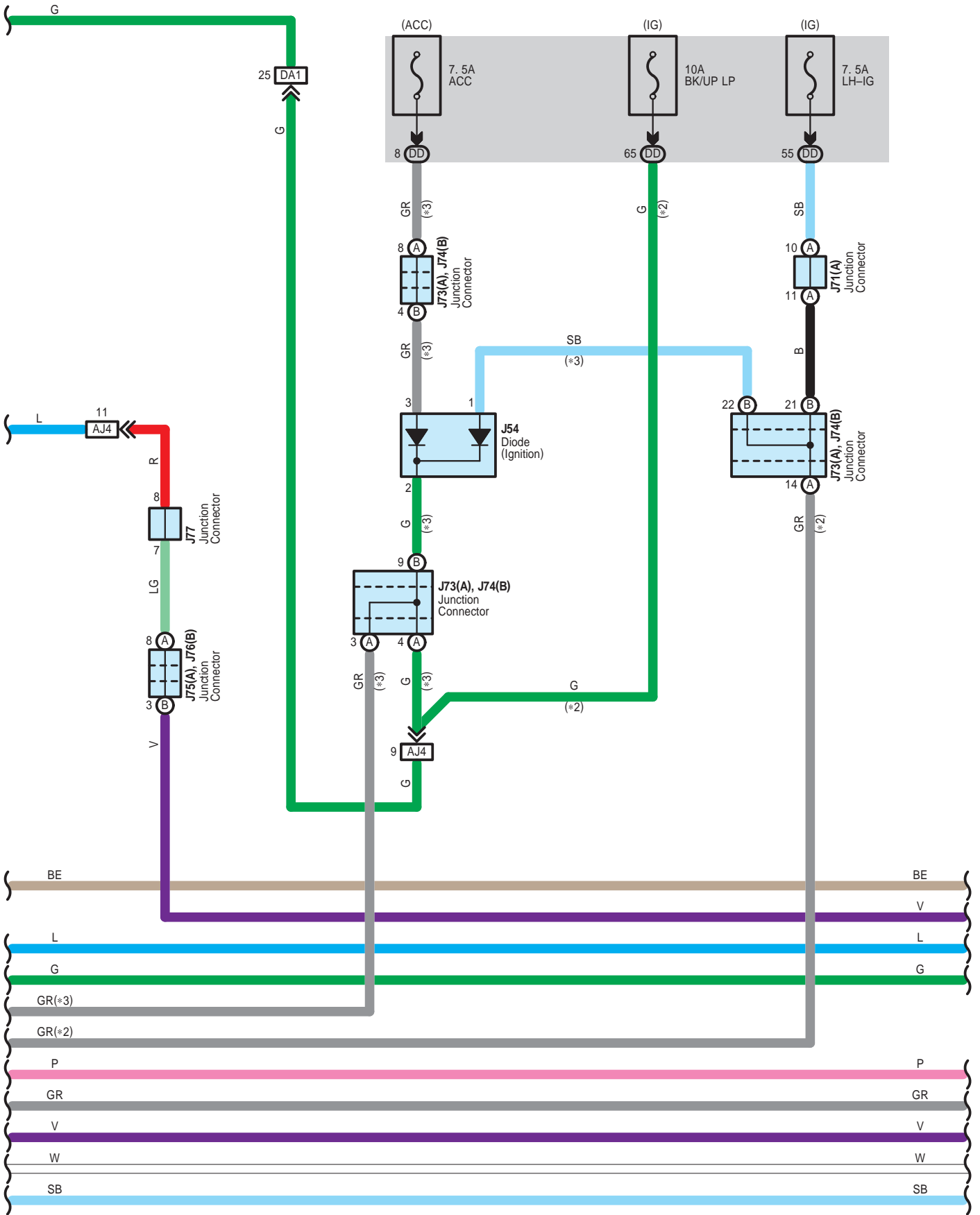

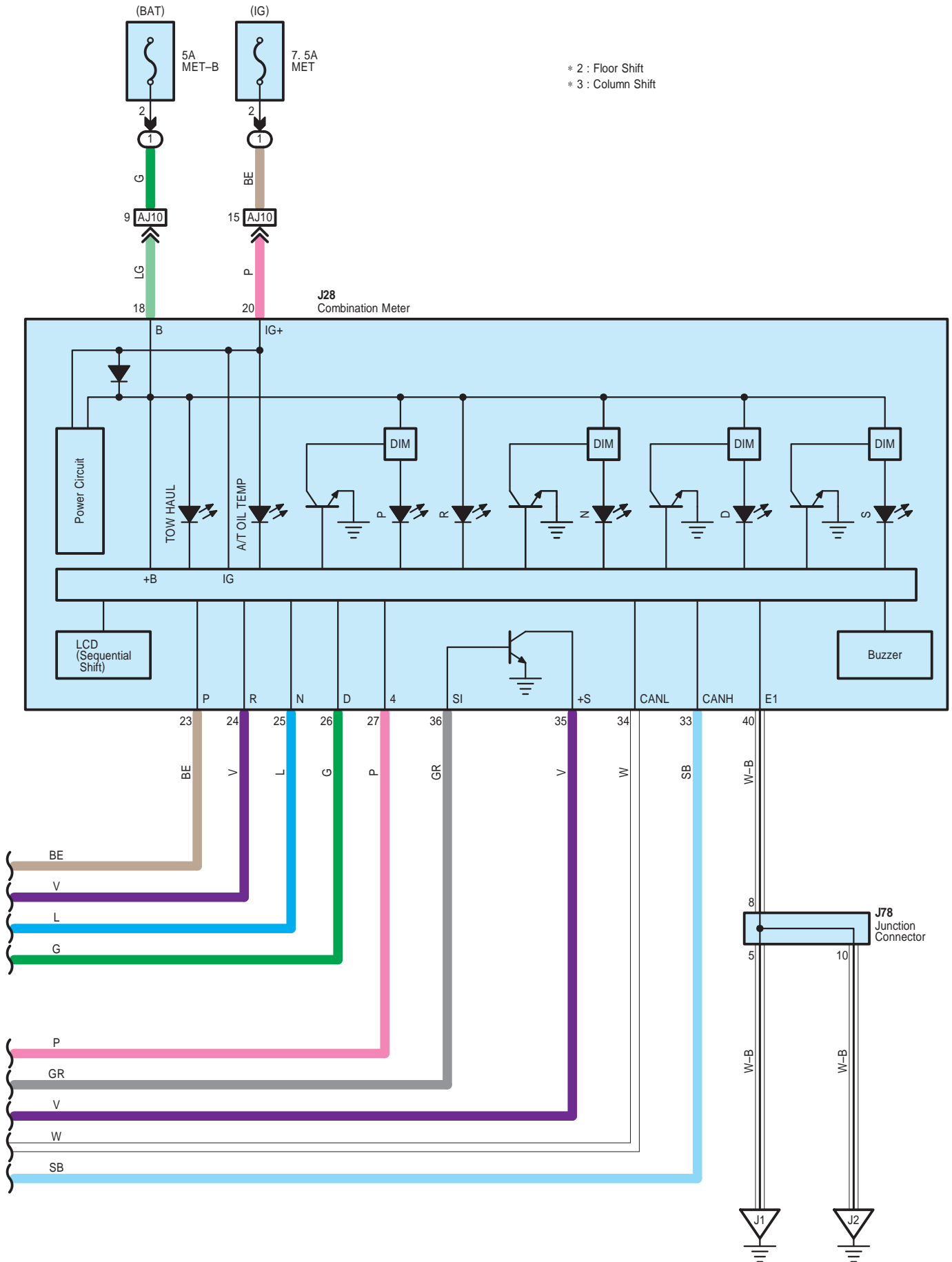

Electronically Controlled Transmission and A/T Indicator <3UR-FE, 3UR-FBE>

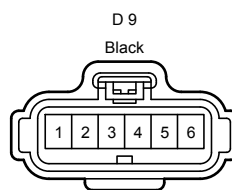
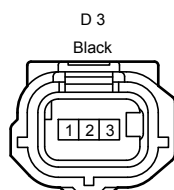
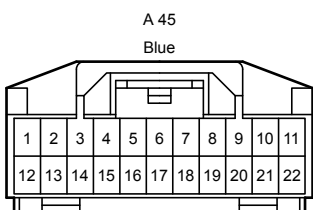
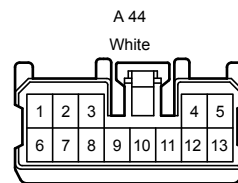
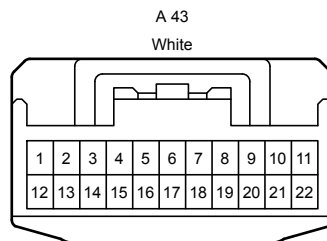
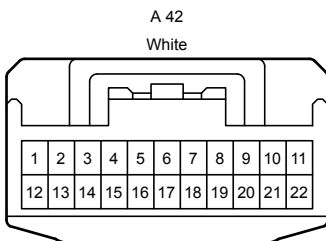
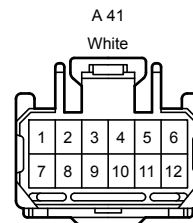
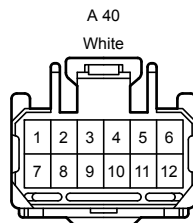
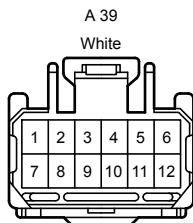
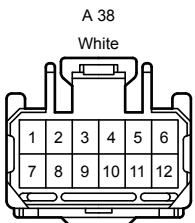
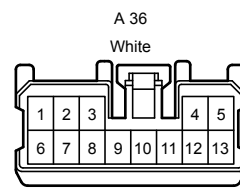
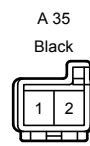
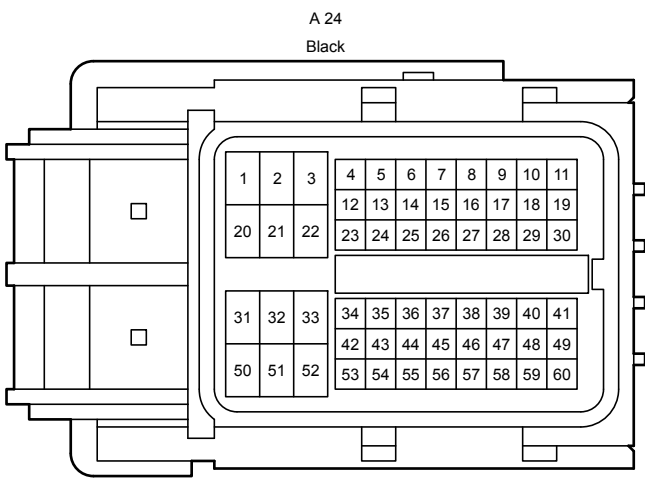
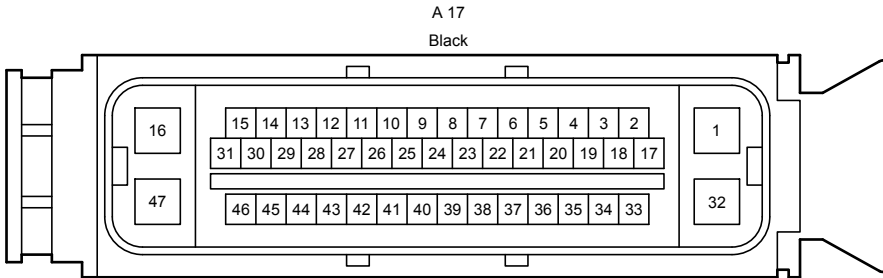
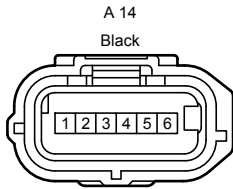
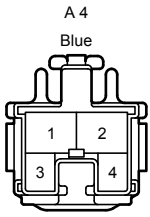

Electronically Controlled Transmission and A/T Indicator <3UR-FE, 3UR-FBE>

D 35  
Gray

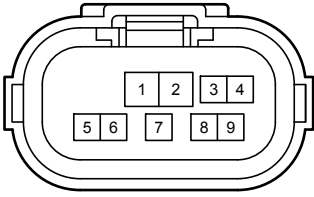

D 63  
Gray

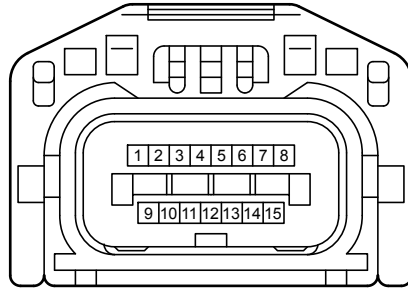

D 64  
Gray

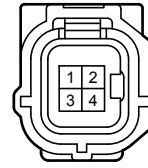

D 65  
Black

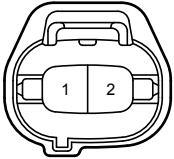

D 66  
Black

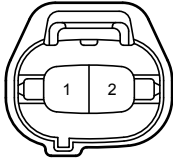

D 73  
Blue

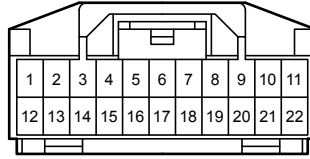

D 74  
Black

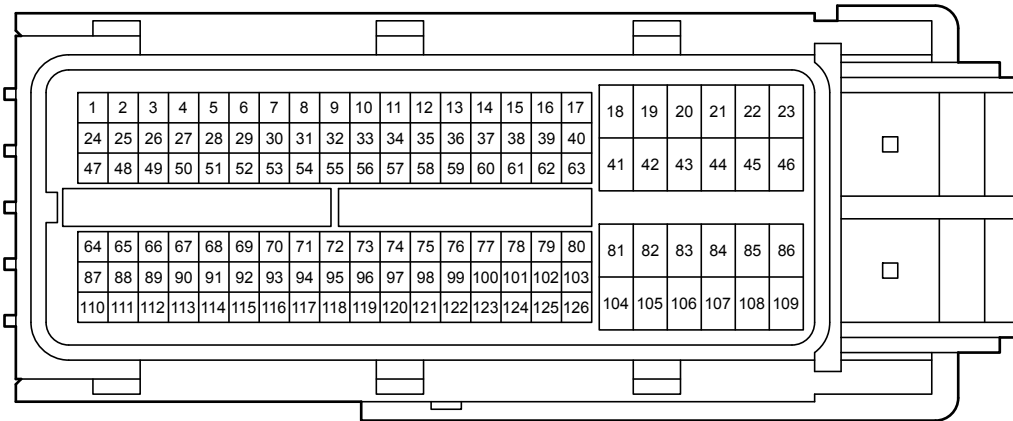

J 9  
White

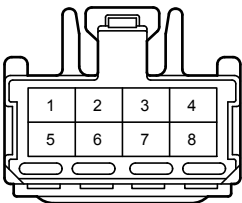

J 17  
White

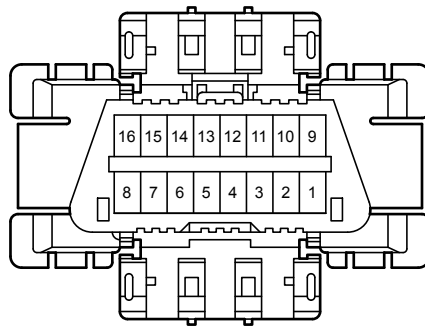

J 23  
Black

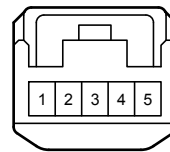

J 24  
White

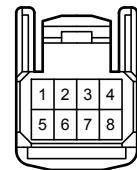

J 25  
White

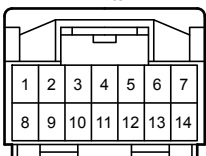

J 28  
White

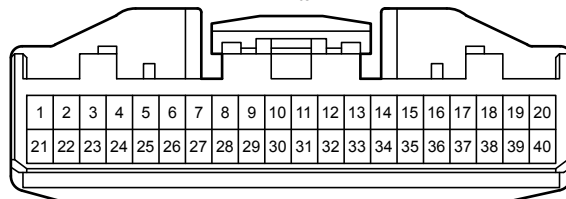

J 54  
Orange



J 71  
Black

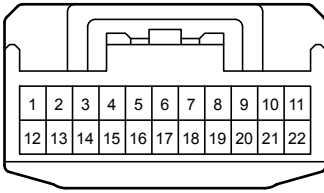

J 73  
Black

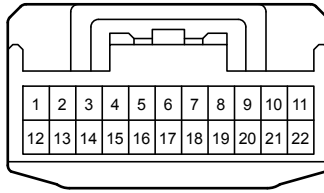

J 74  
Black

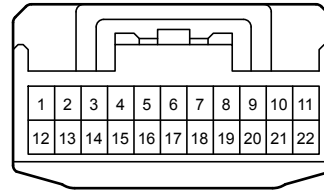

J 75  
White

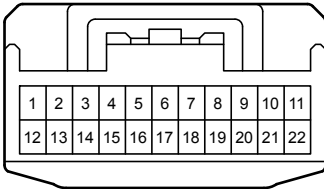

J 76  
White

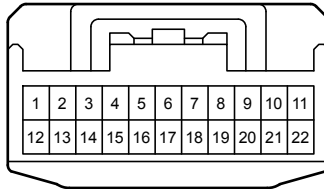

J 77  
Gray

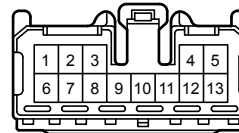

J 78  
White

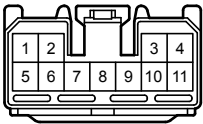

J 79  
White

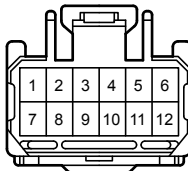

J 80  
White

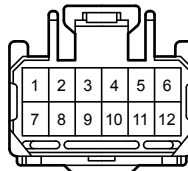

J113  
Gray

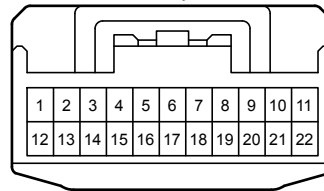

J117  
Black

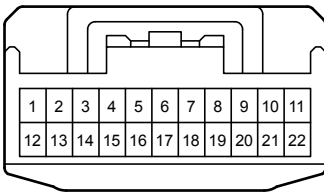

J118  
Gray

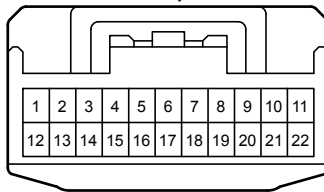

1B  
White

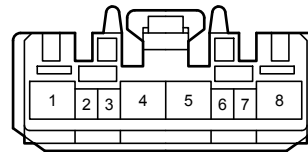

DD  
White

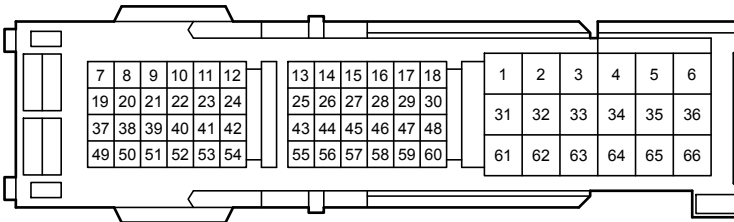

AJ4  
White

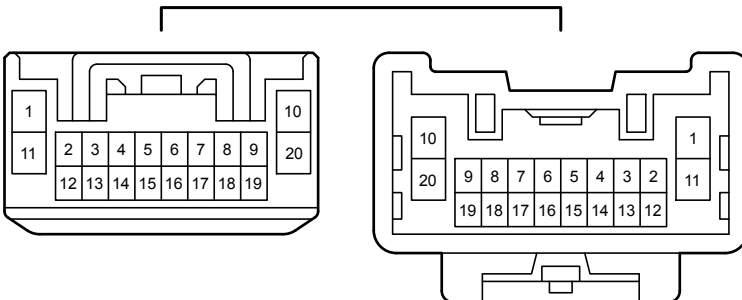

AJ5  
White

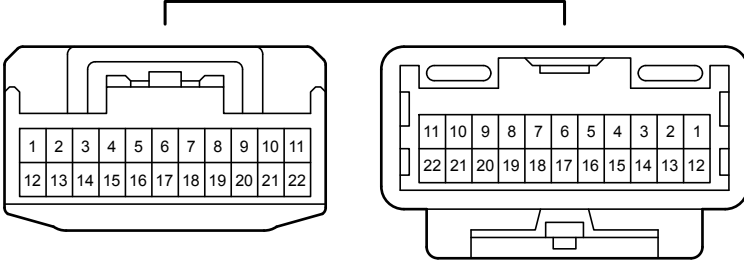

AJ9  
Gray

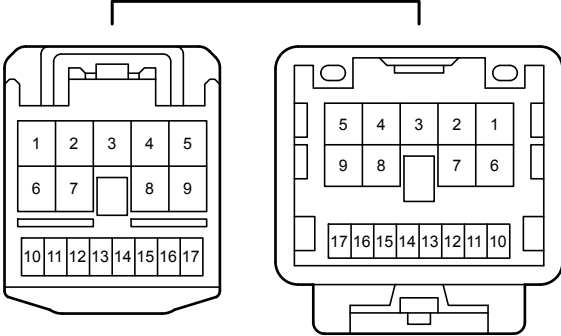

AJ10  
Gray

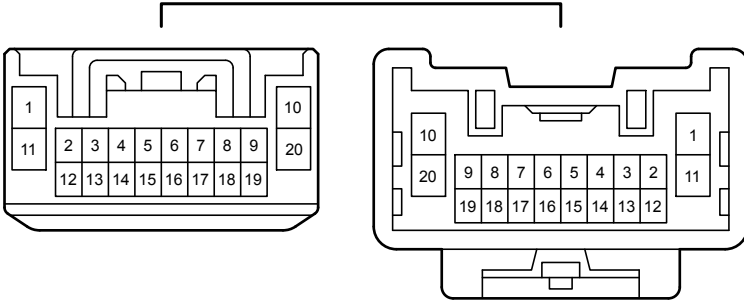

AJ11  
Gray

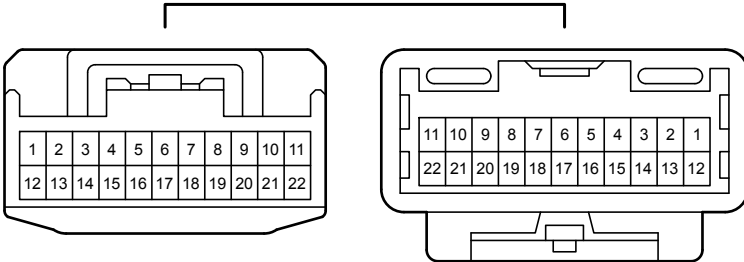

DA1  
White

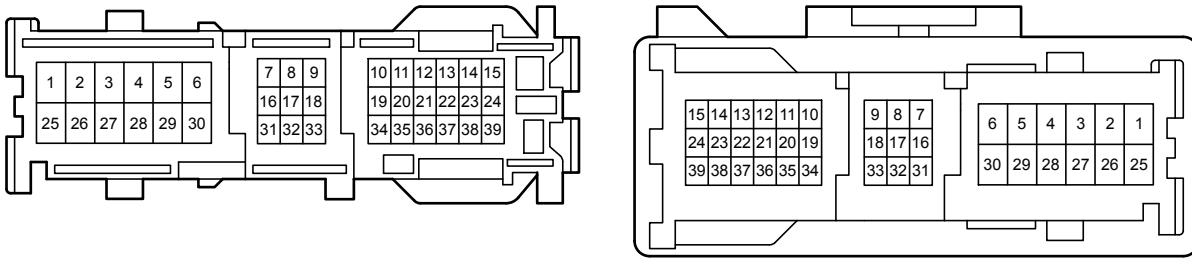

DA2  
White

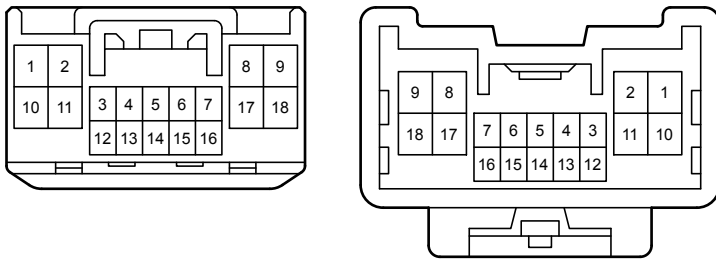

Engine Control <1GR-FE>

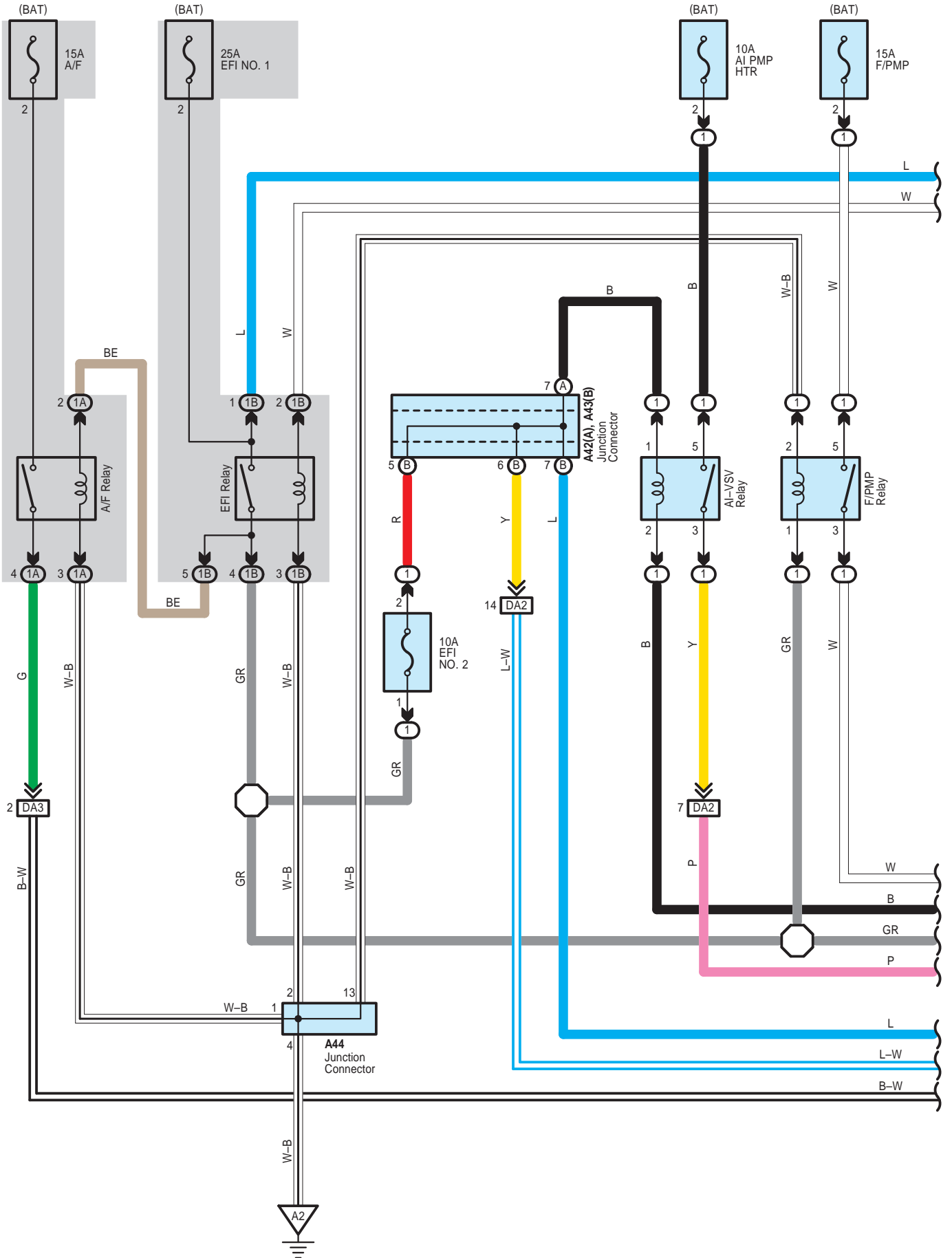



Engine Control <1GR-FE>

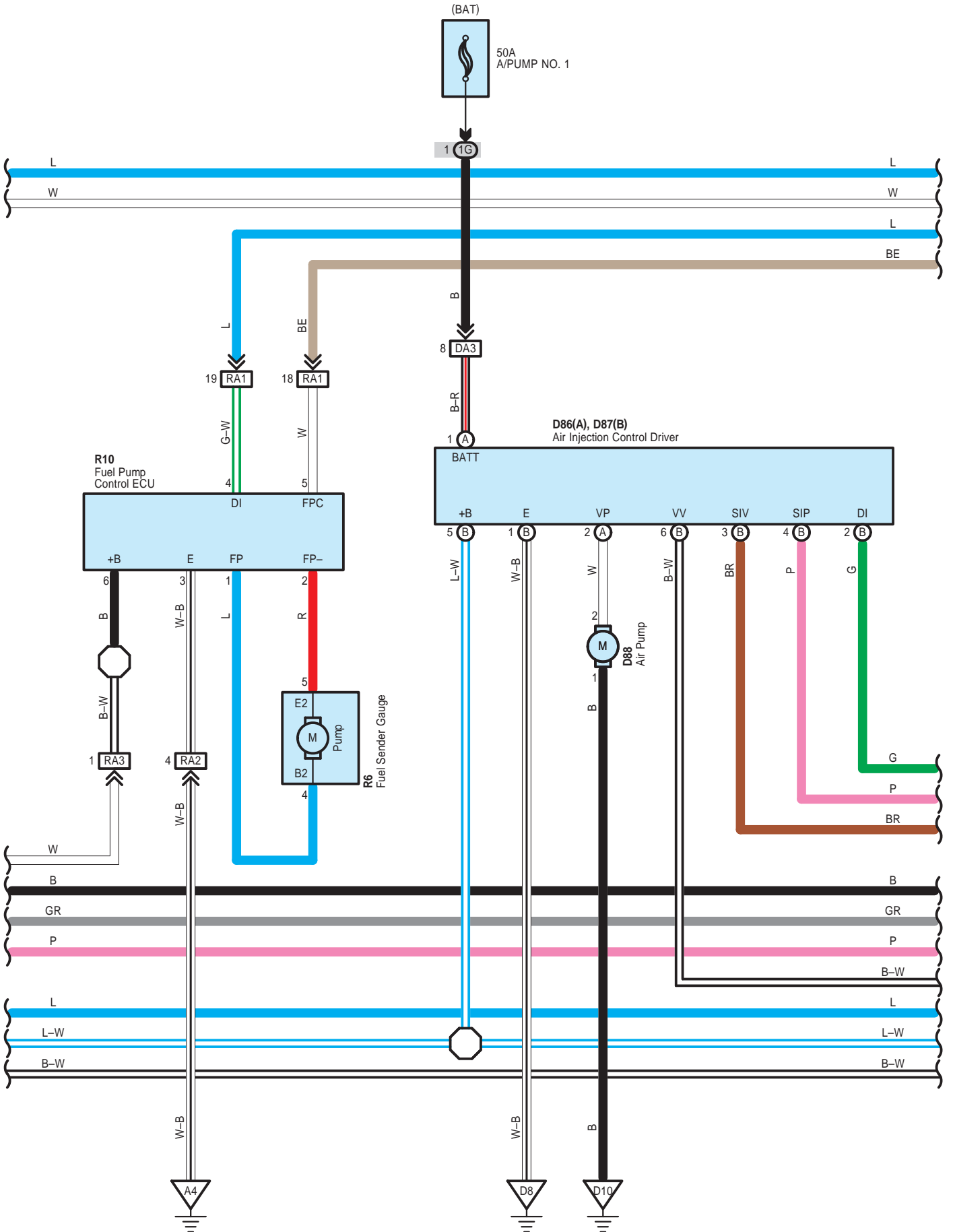

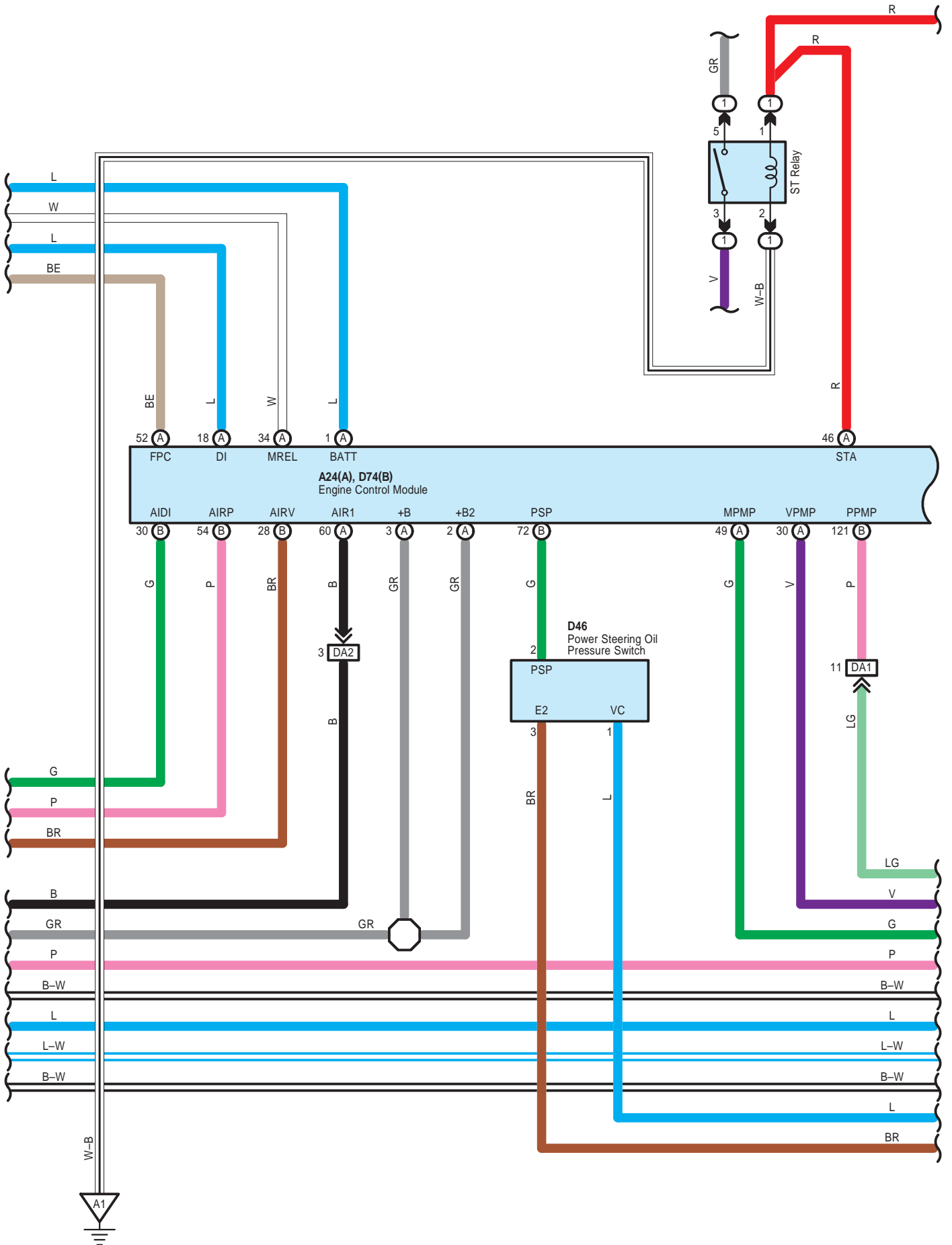

Engine Control <1GR-FE>

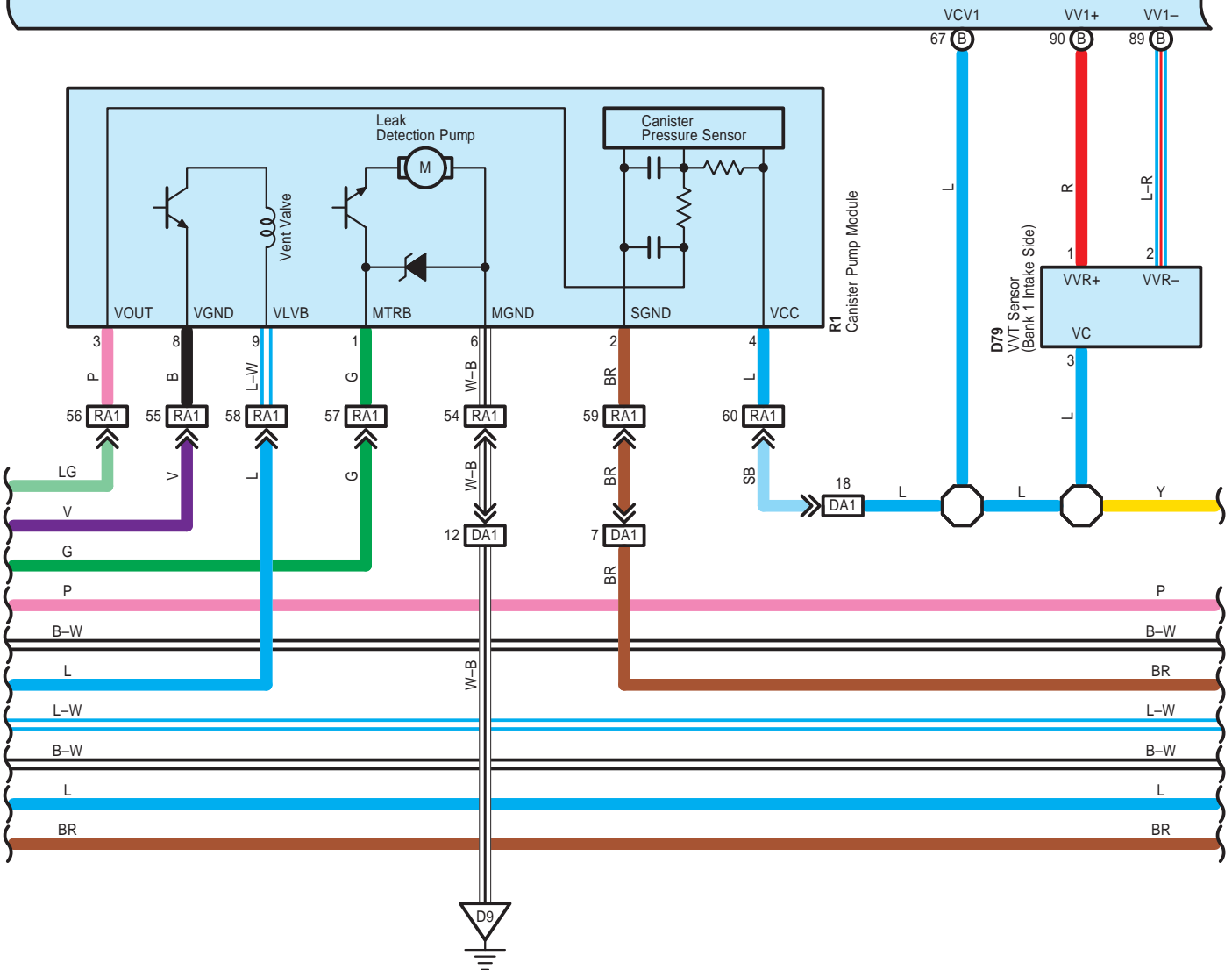
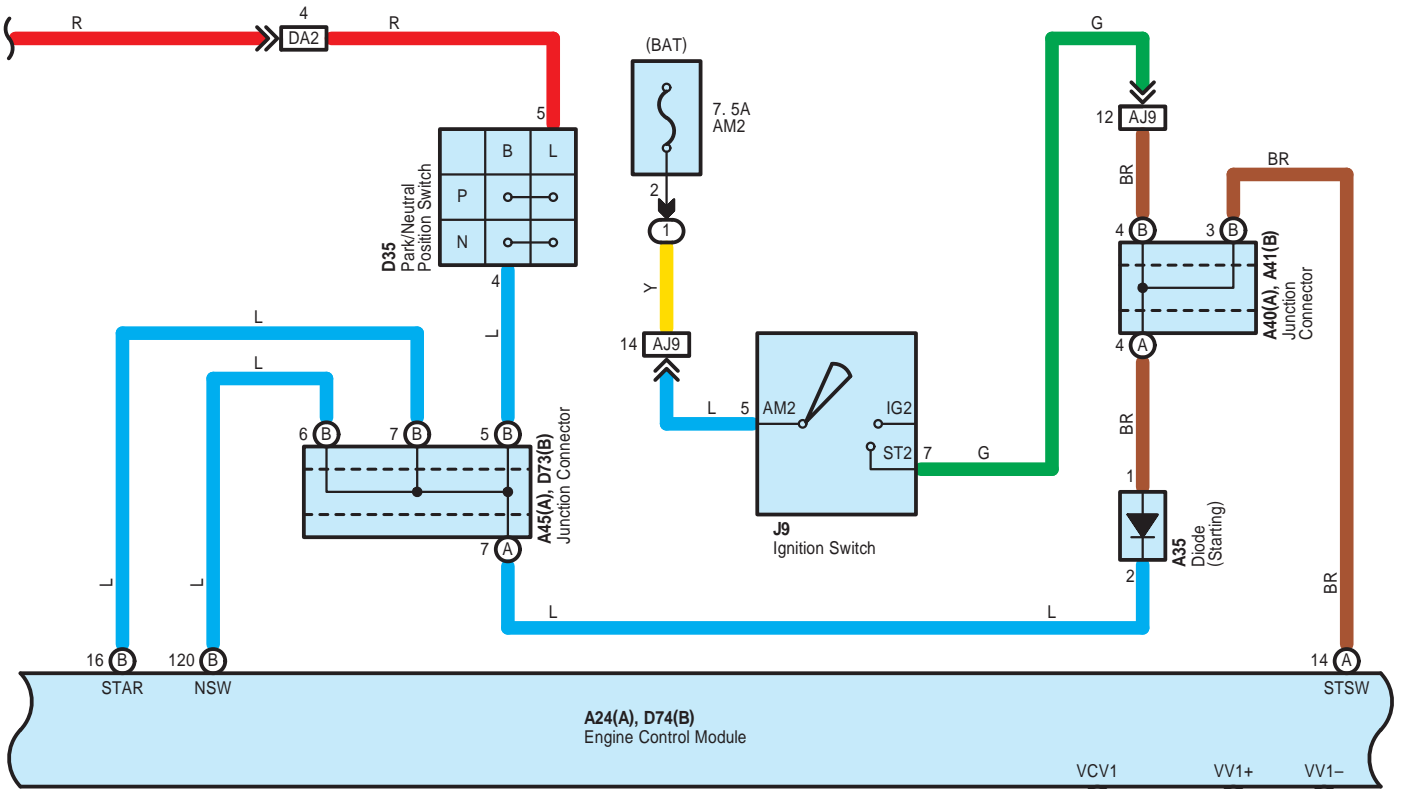

Engine Control <1GR-FE>

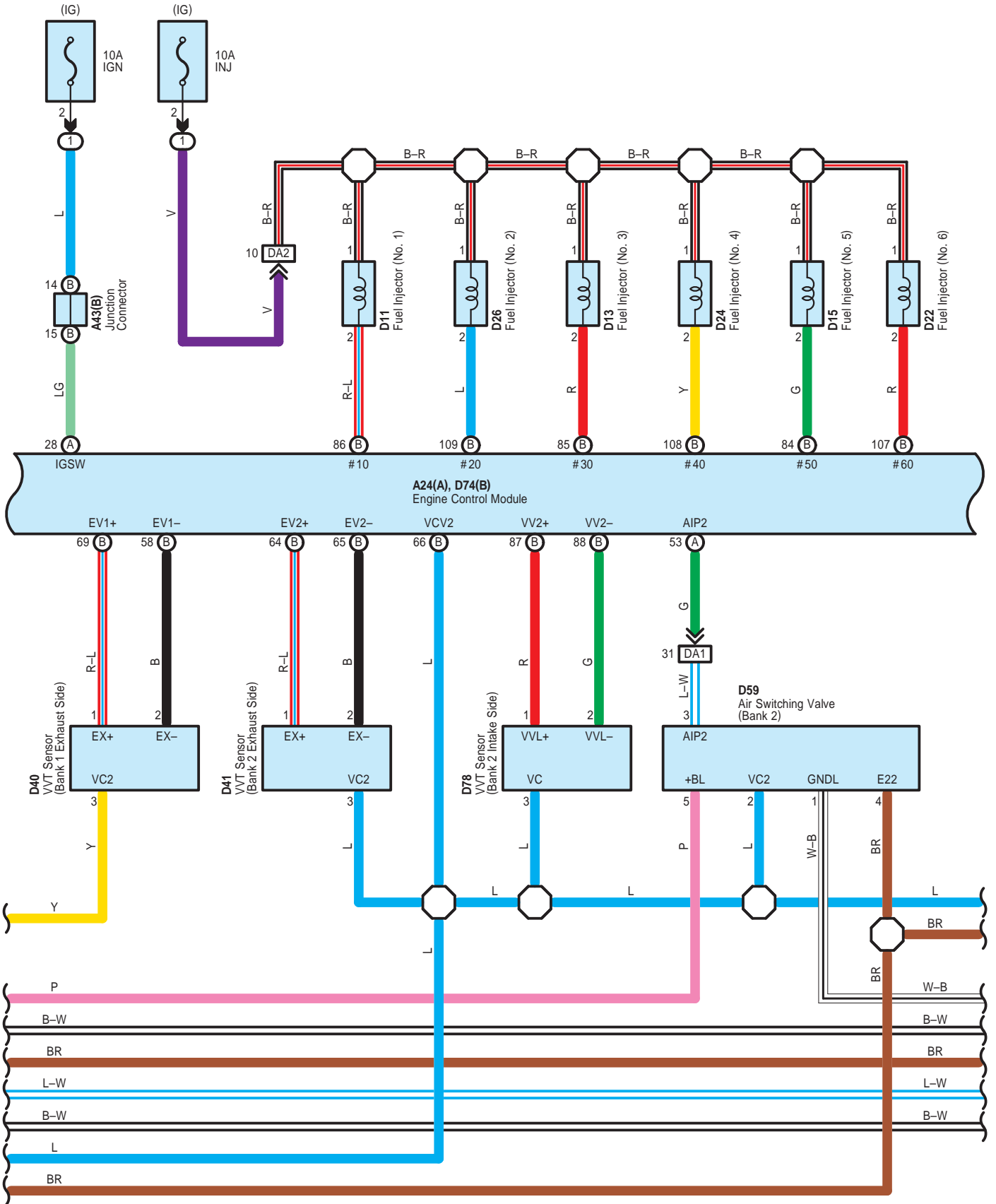

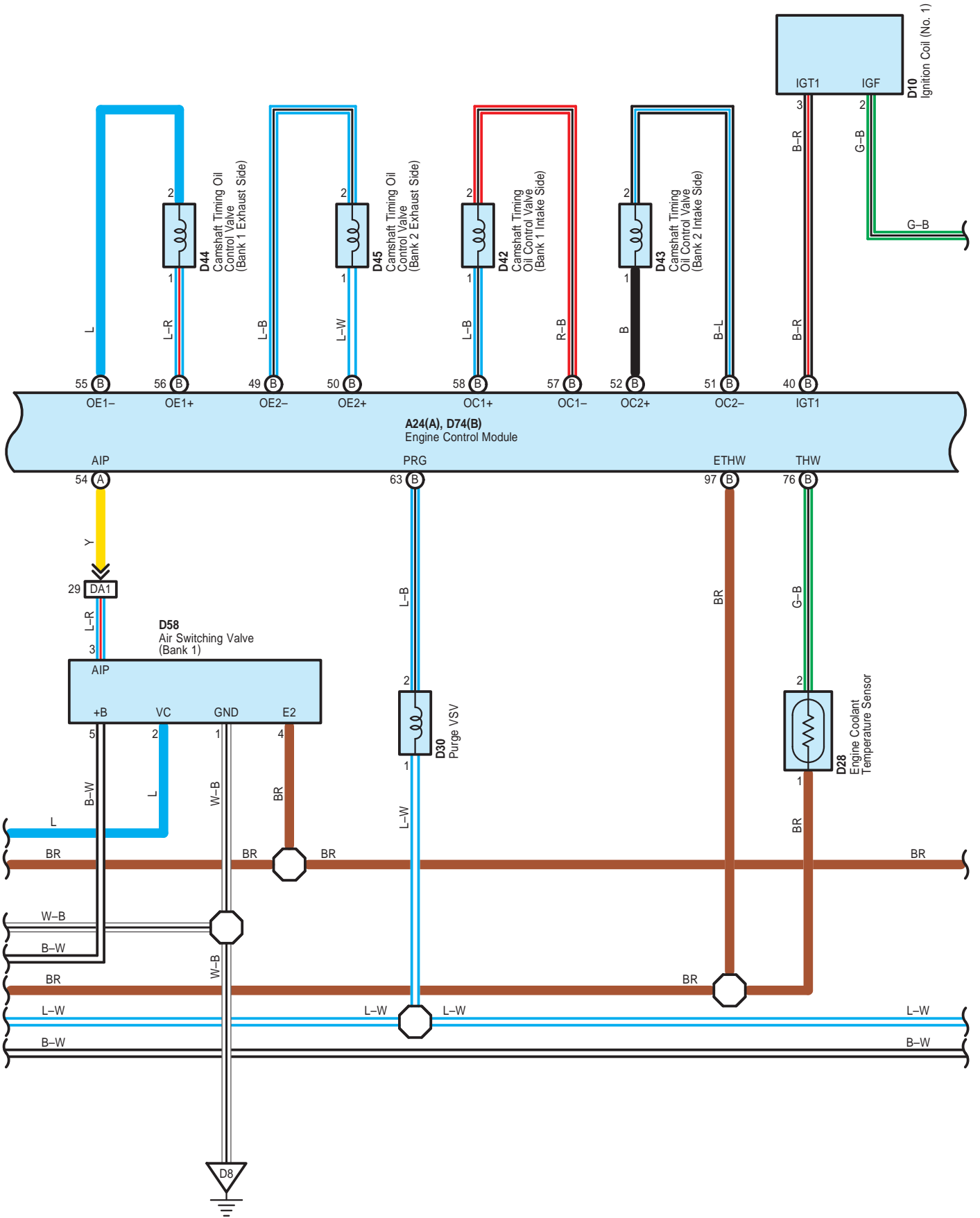

Engine Control <1GR-FE>

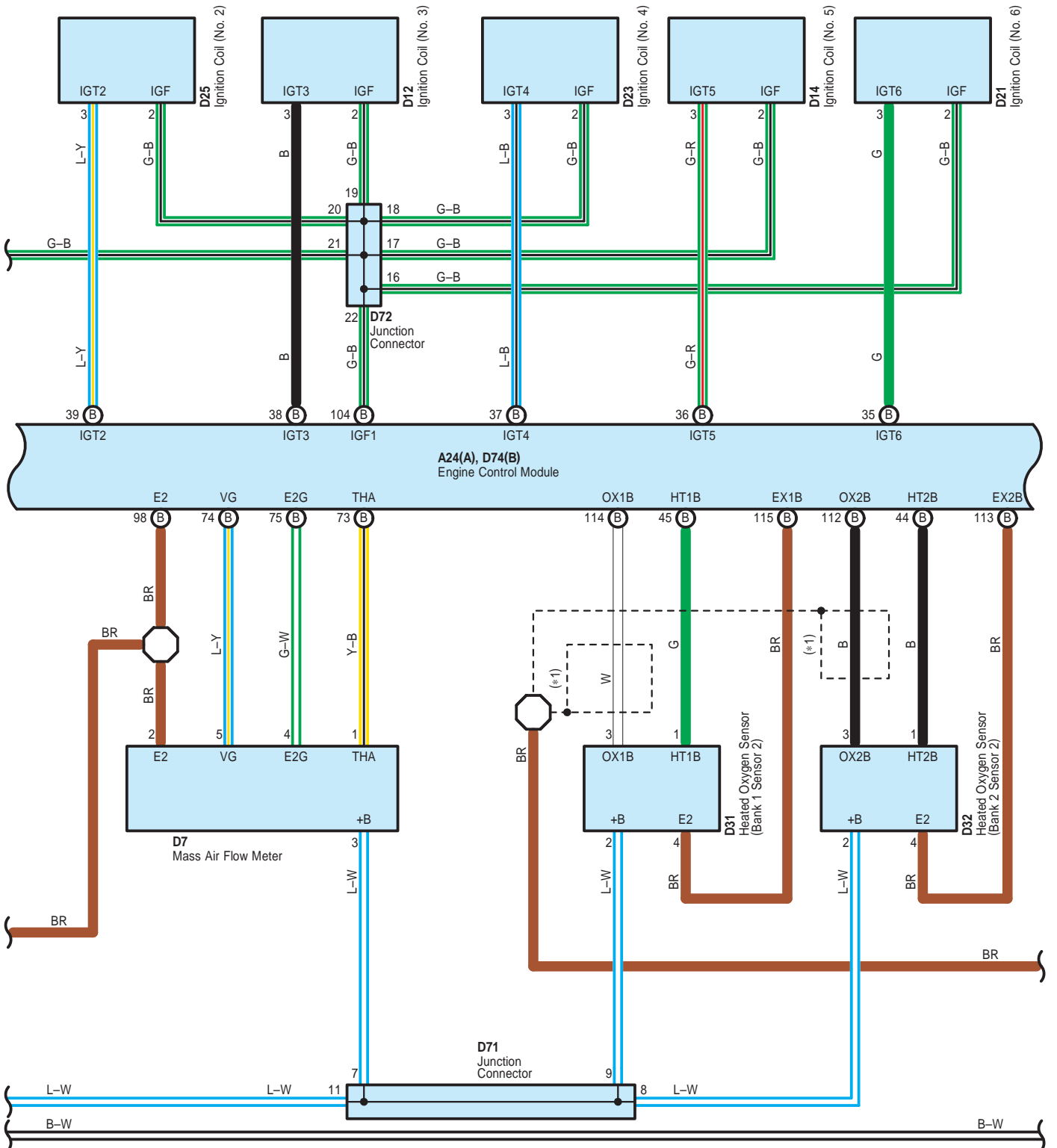

\* 1 : Shielded

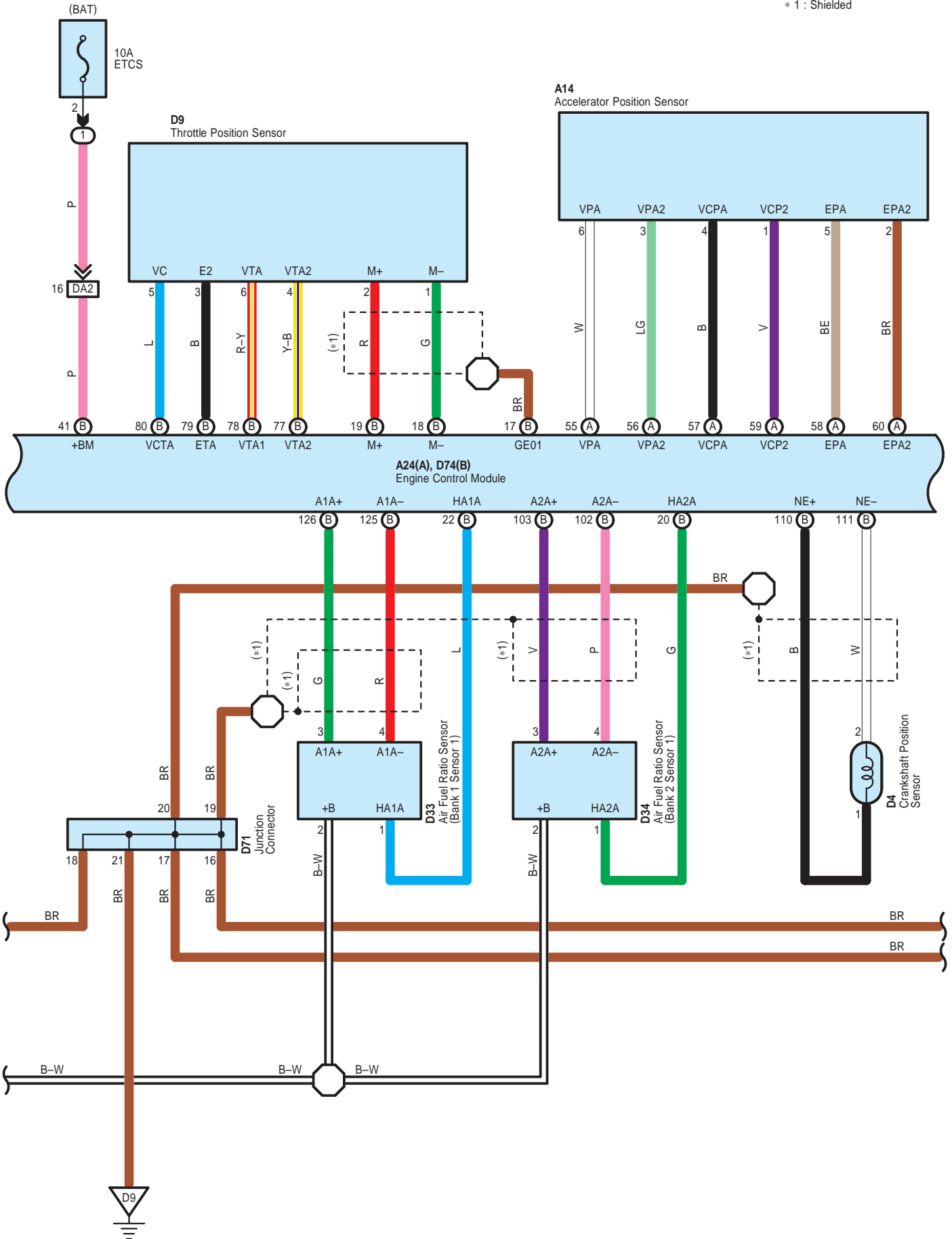

Engine Control <1GR-FE>

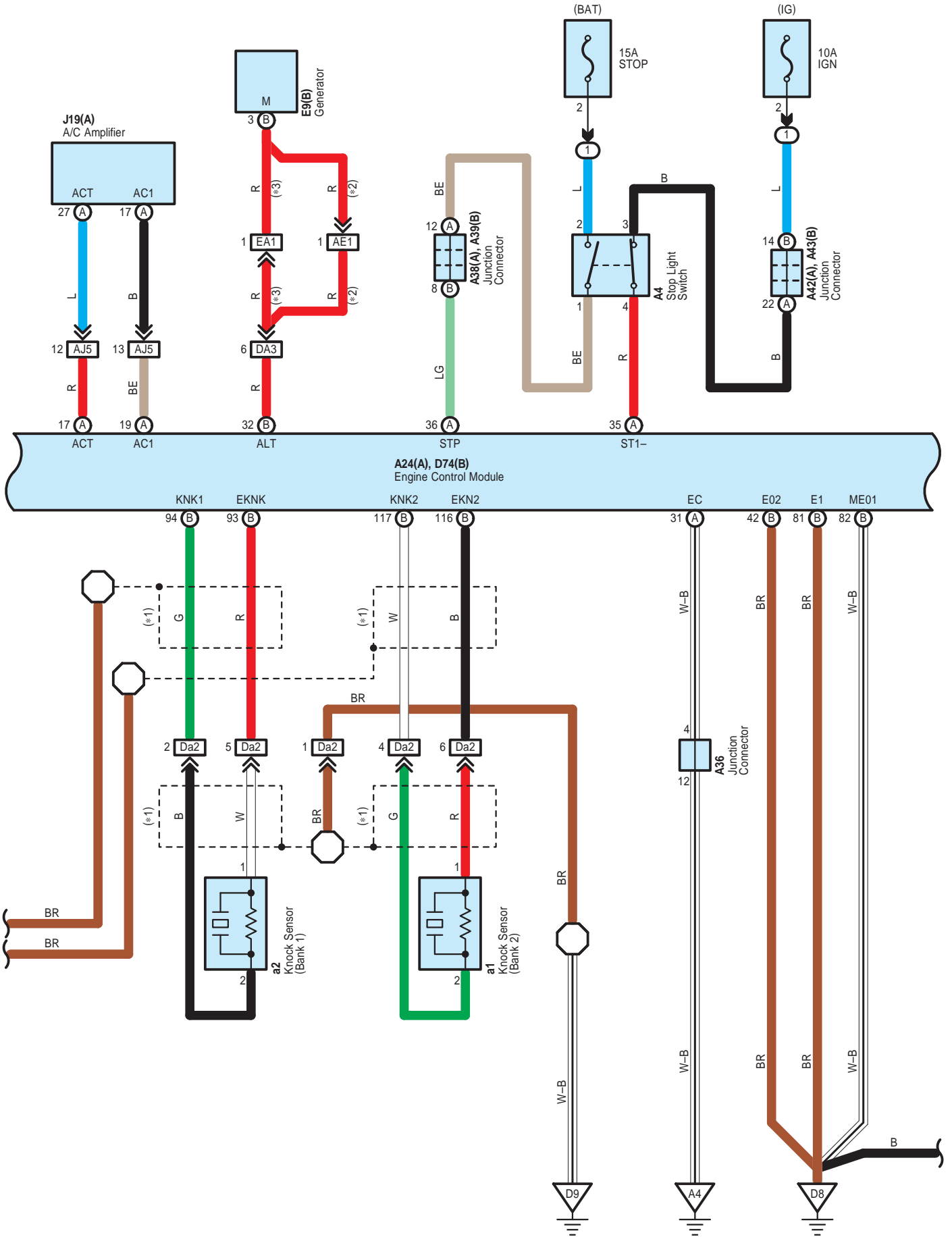



- \* 1 : Shielded
- \* 2 : Before Oct. 2010 Production
- \* 3 : From Oct. 2010 Production

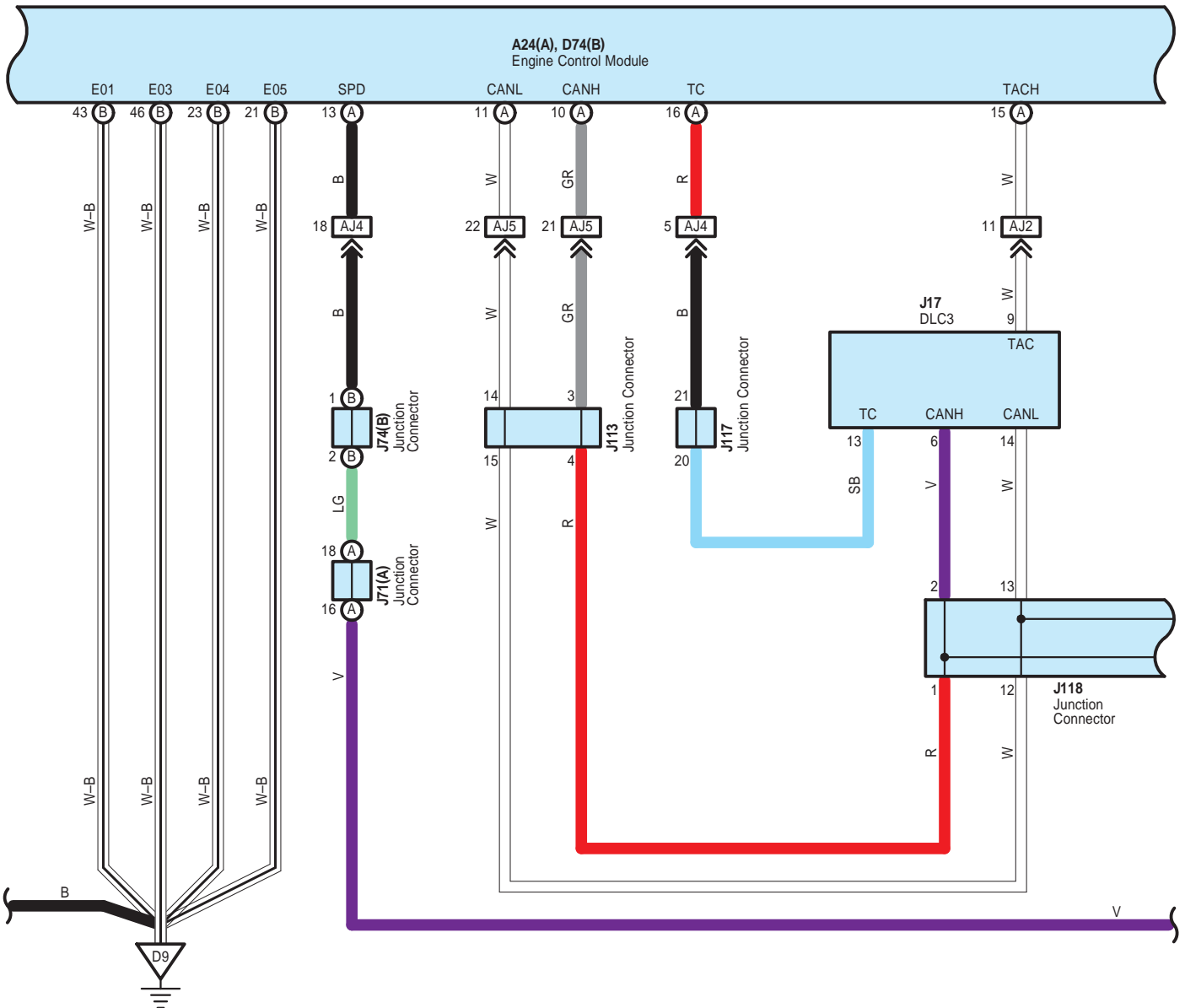

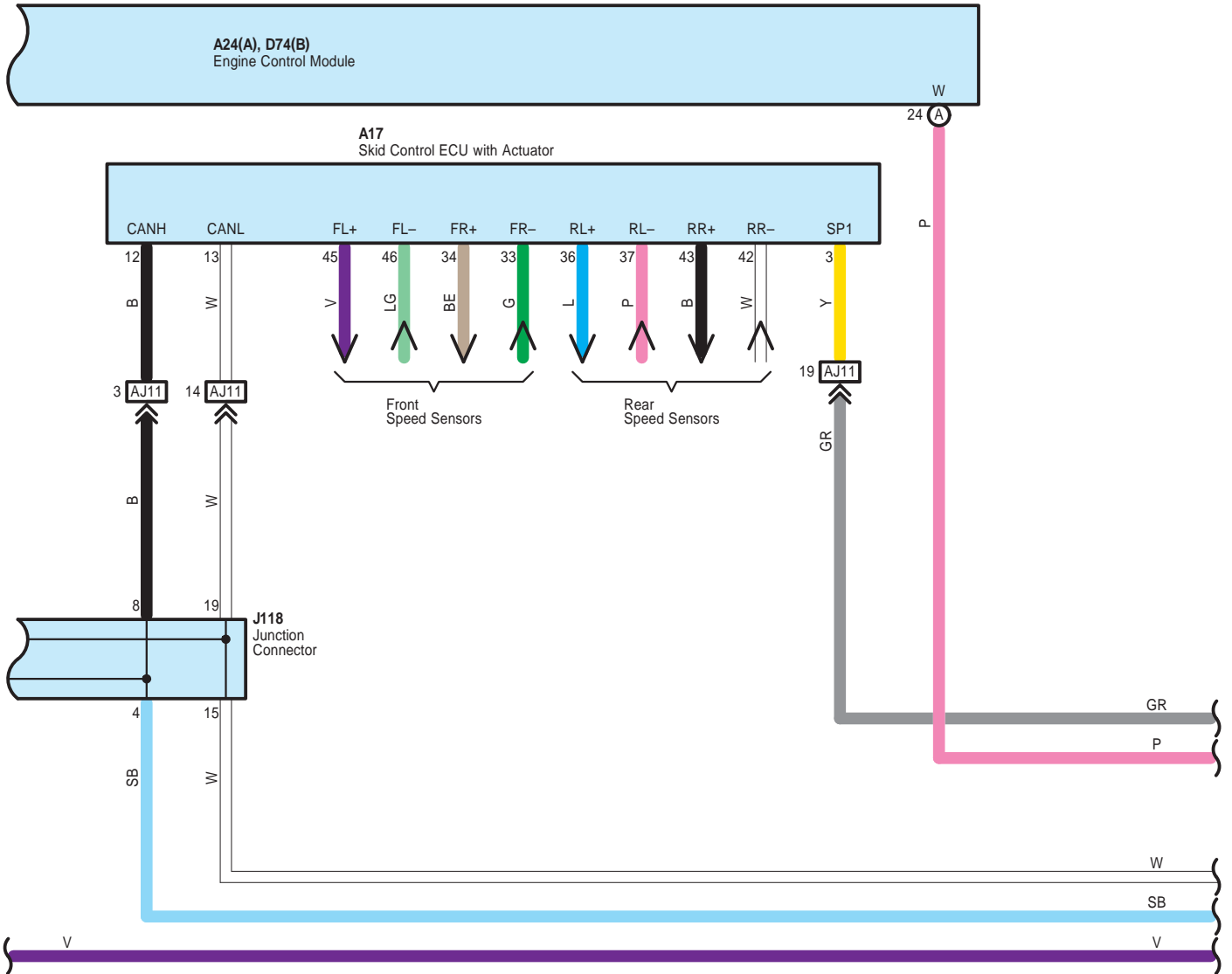

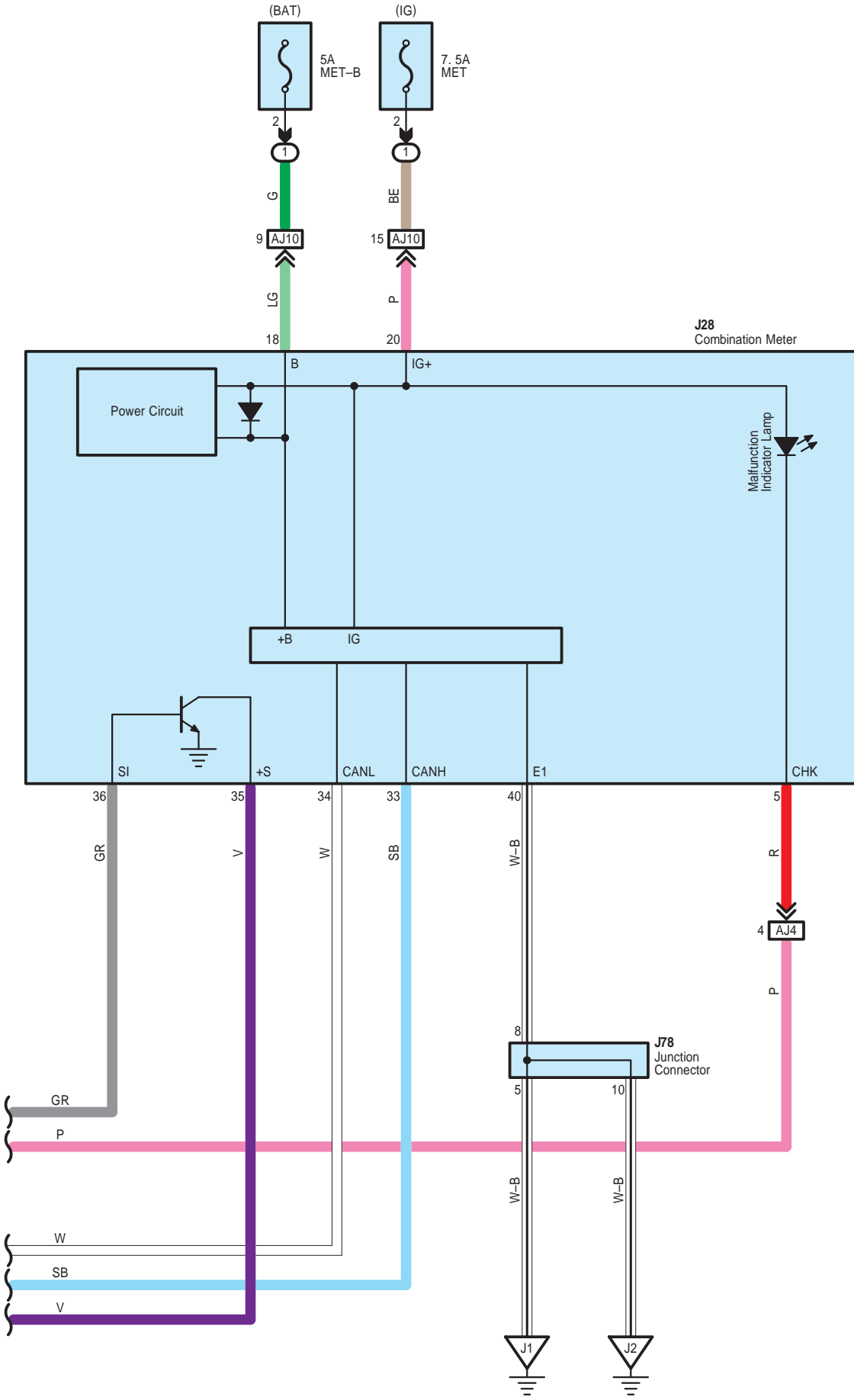

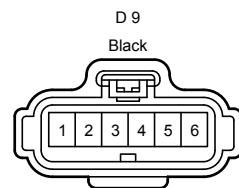
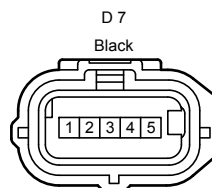
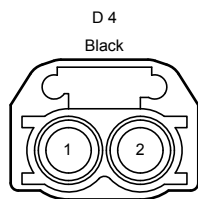
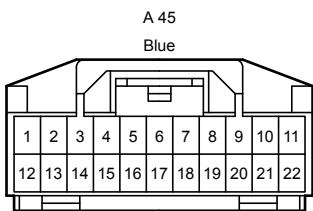
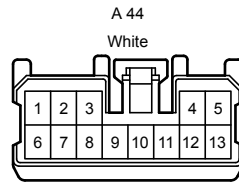
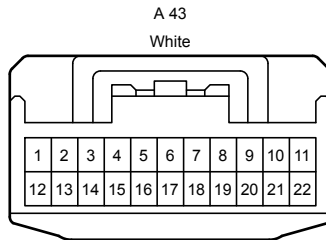
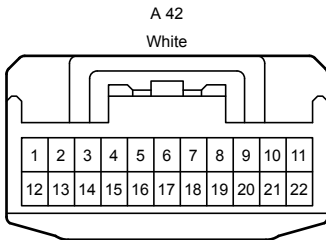
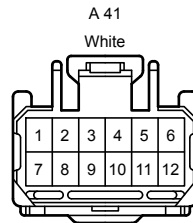
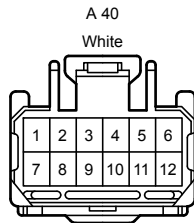
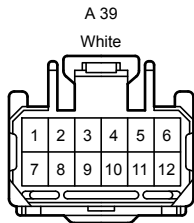
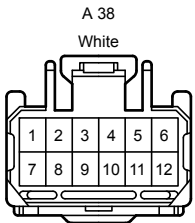
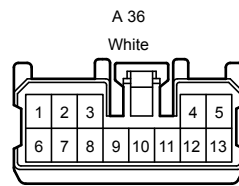
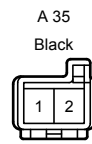
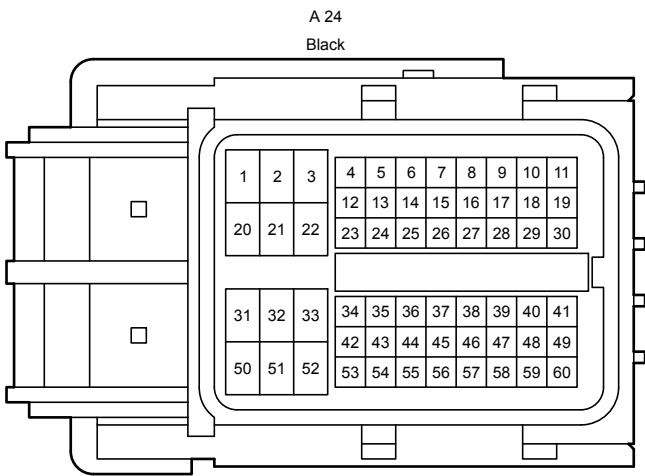
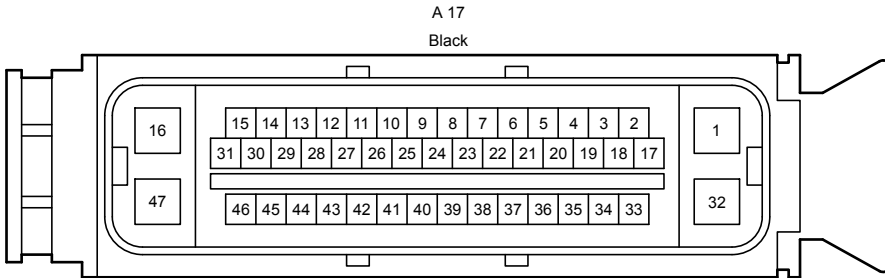
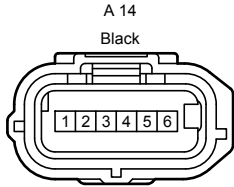
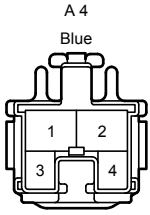

Engine Control <1GR-FE>

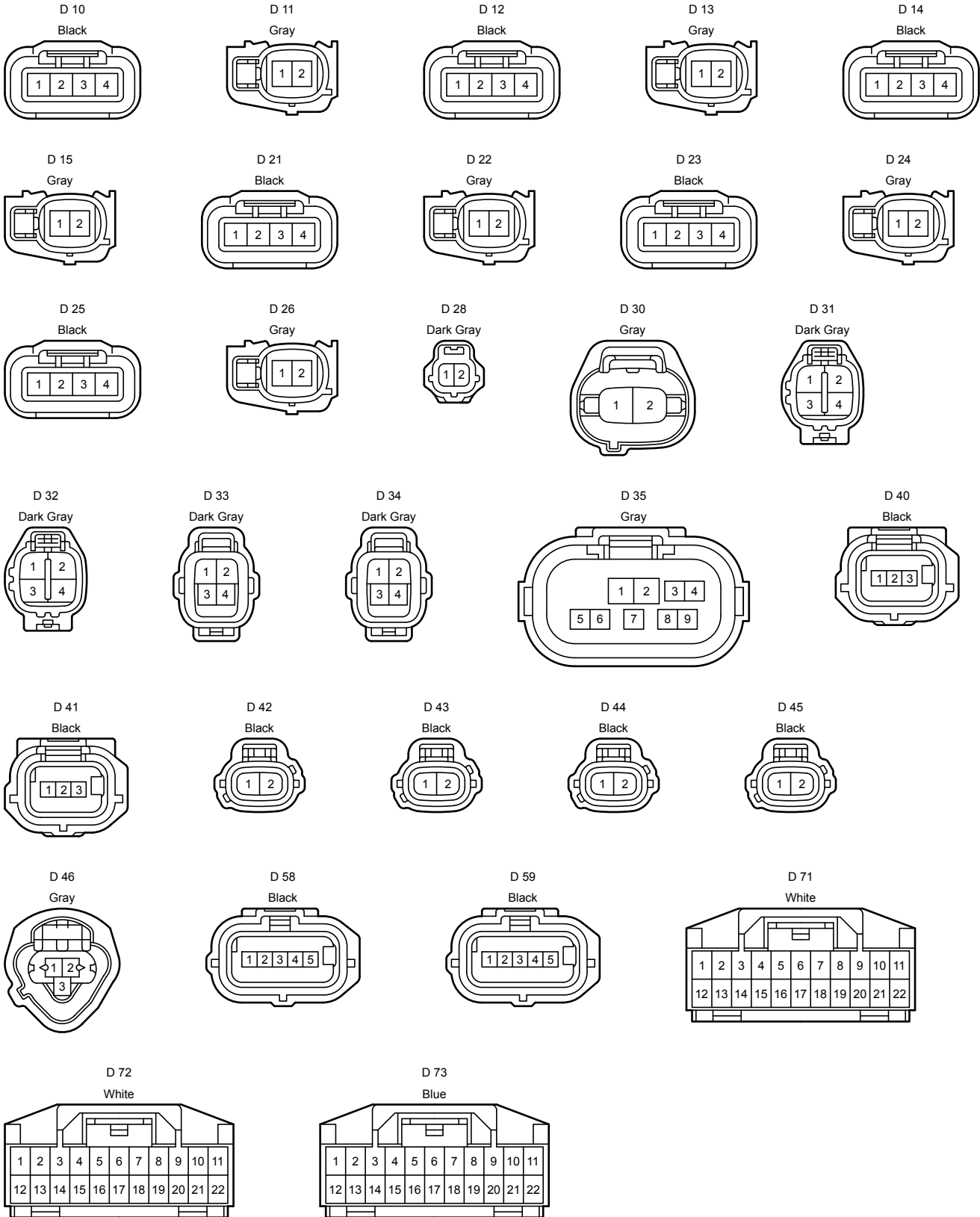

Engine Control <1GR-FE>

D 74  
Black

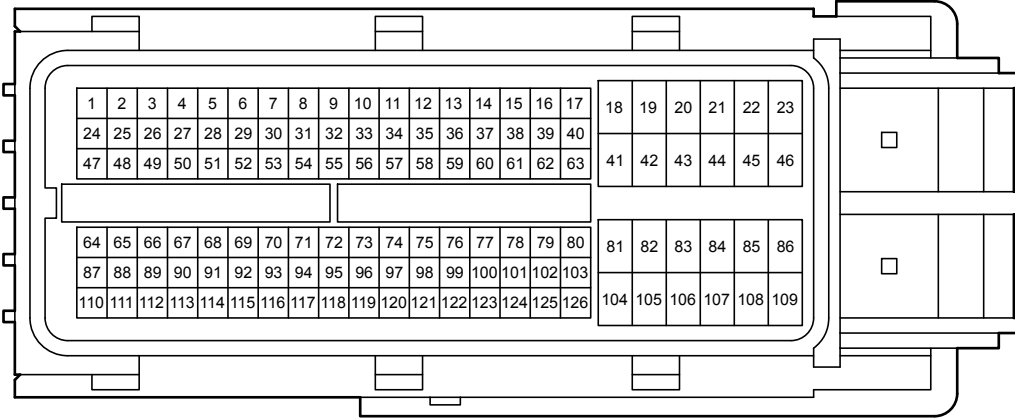

D 78  
Black

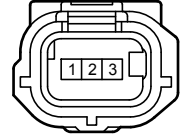

D 79  
Black

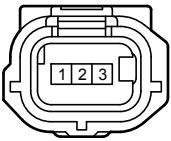

D 86  
Black

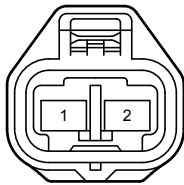

D 87  
Black

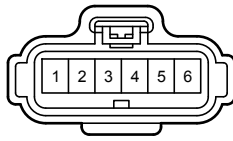

D 88  
Gray

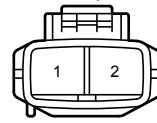

E 9  
Black

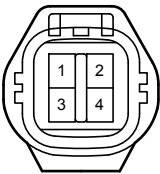

J 9  
White

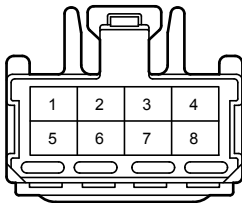

J 17  
White

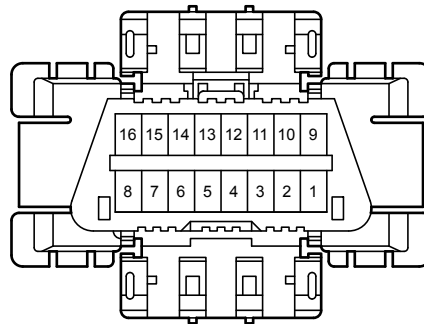

J 19  
White

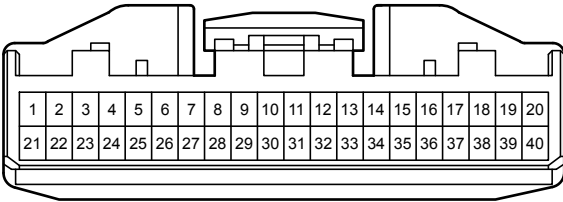

J 28  
White

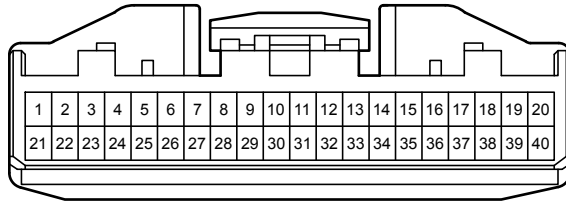

J 71  
Black

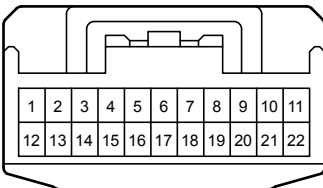

J 74  
Black

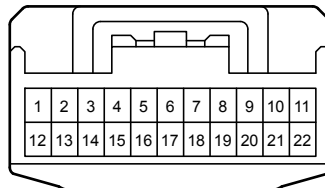

J 78  
White

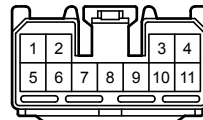

J113  
Gray

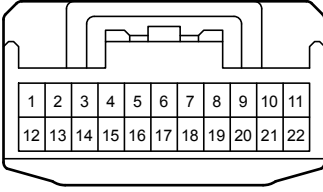

J117  
Black

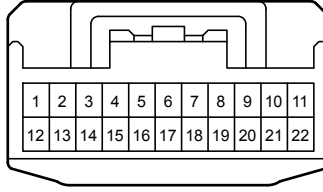

J118  
Gray

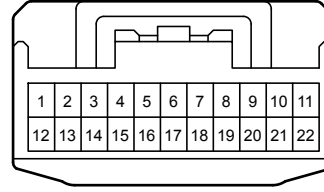

R 1  
Black

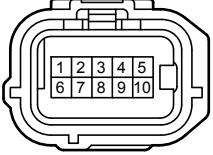

R 6  
White

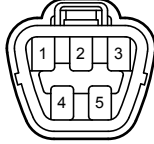

R 10  
Black

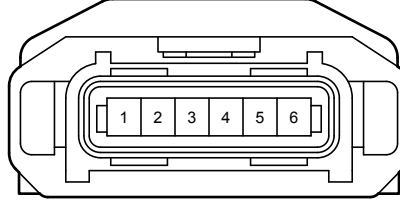

a 1  
Black

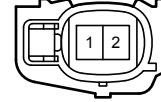

a 2  
Black

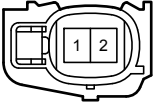

1A  
White

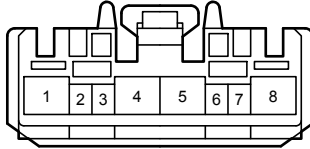

1B  
White

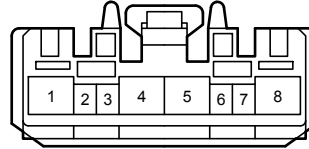

1G

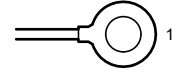

1H

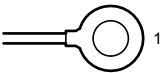

AE1  
Gray

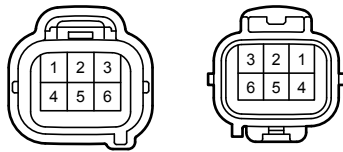

AJ2  
White

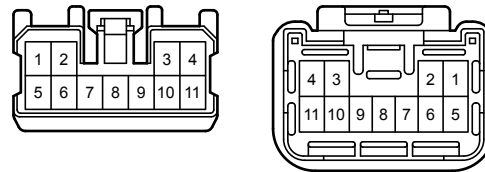

AJ4  
White

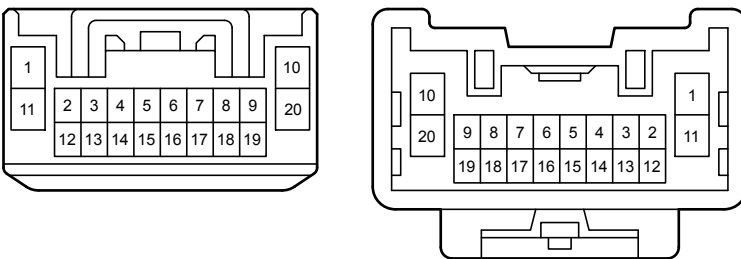

AJ5  
White

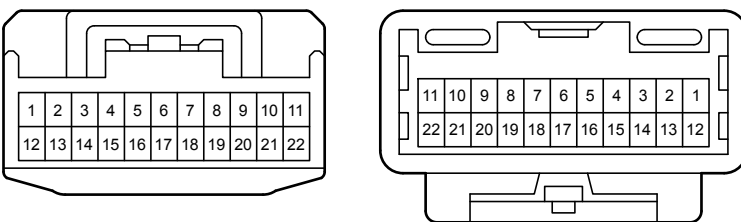

AJ9  
Gray

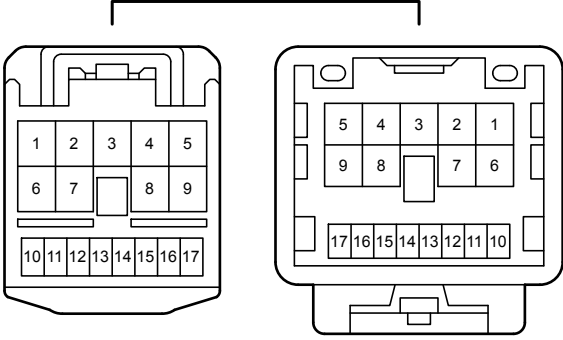

AJ10  
Gray

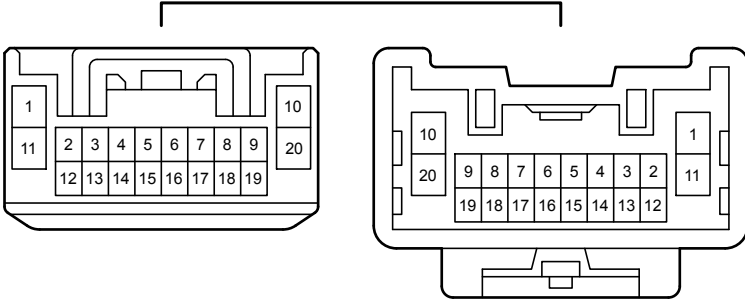

AJ11  
Gray

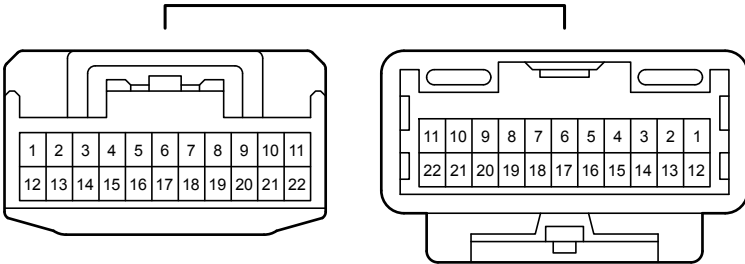

DA1  
White

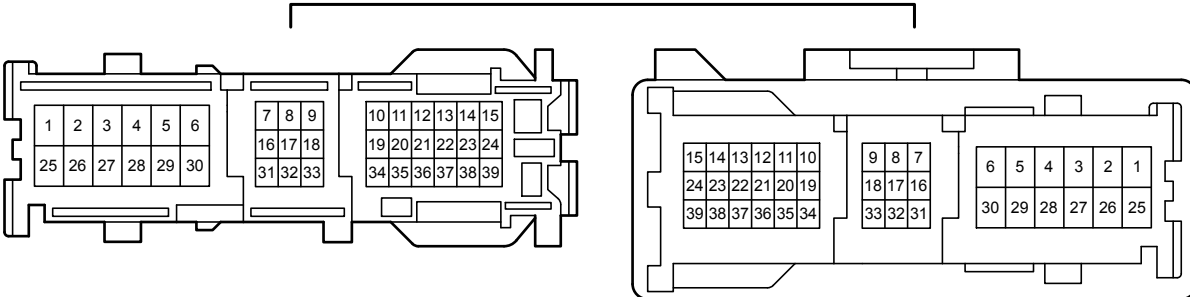



DA2  
White

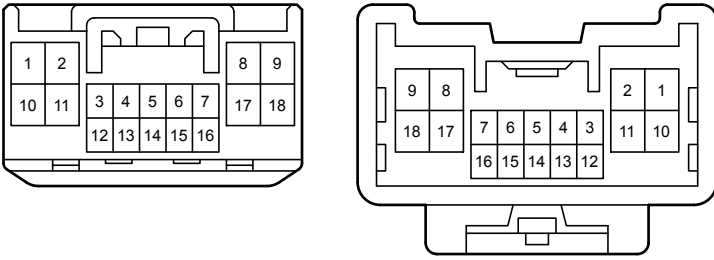

DA3  
White

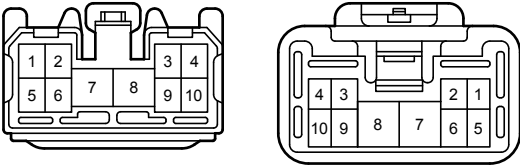

Da2

Gray      Dark Gray

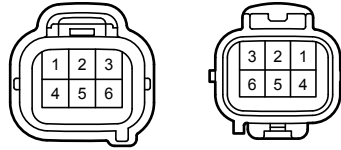

EA1  
Gray

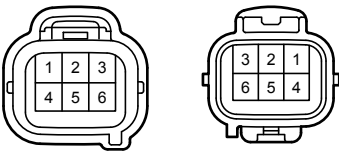

RA1  
White

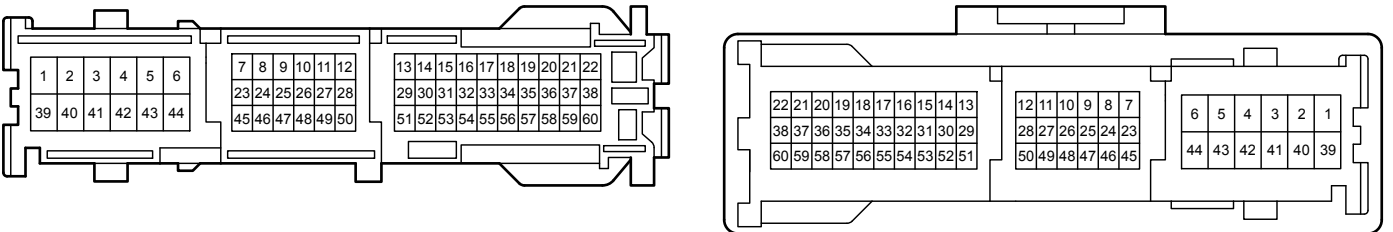

RA2  
White

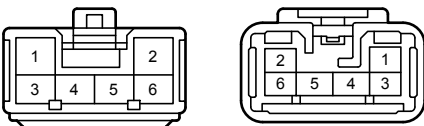

RA3  
White

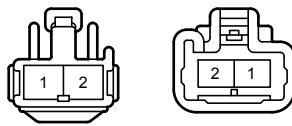

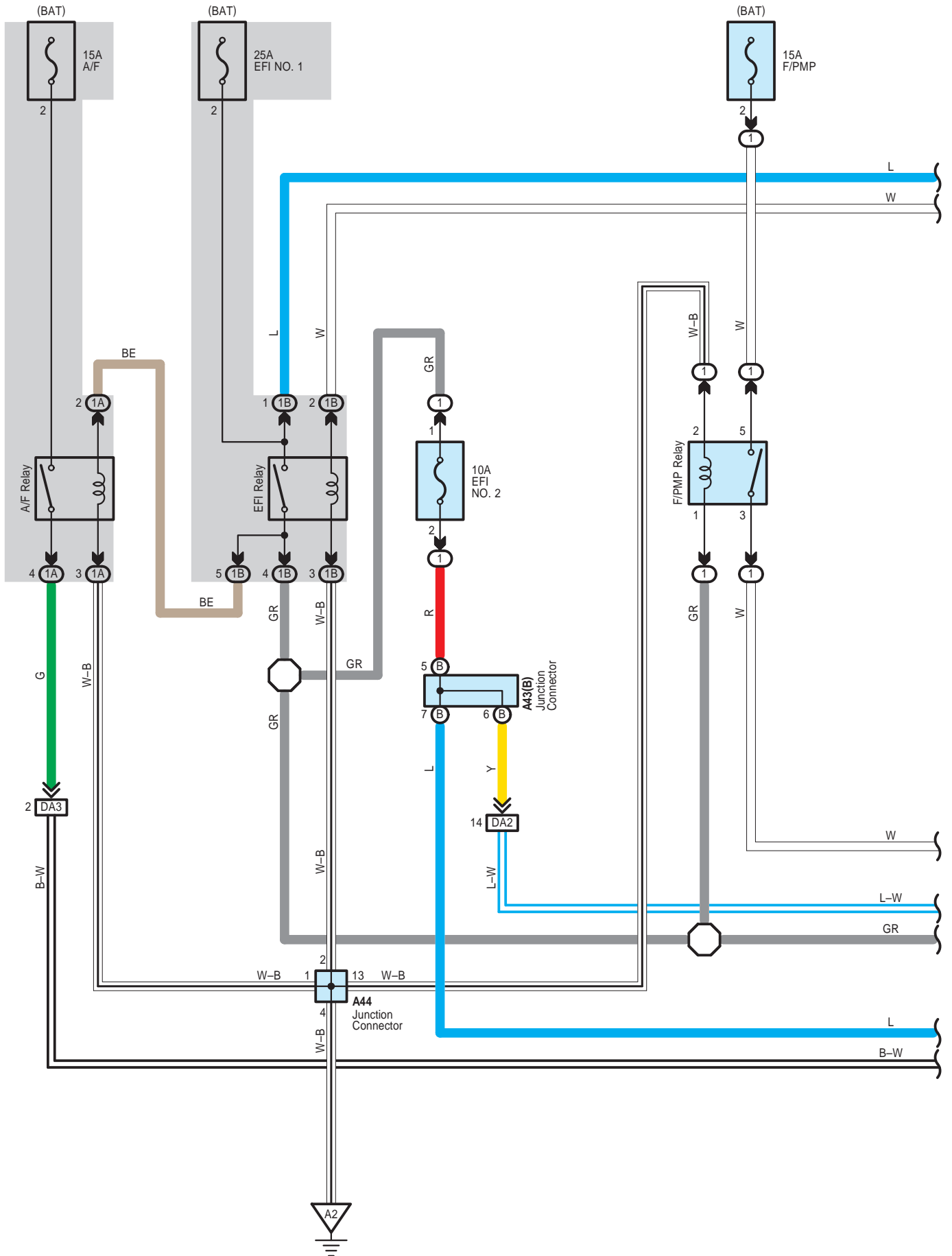



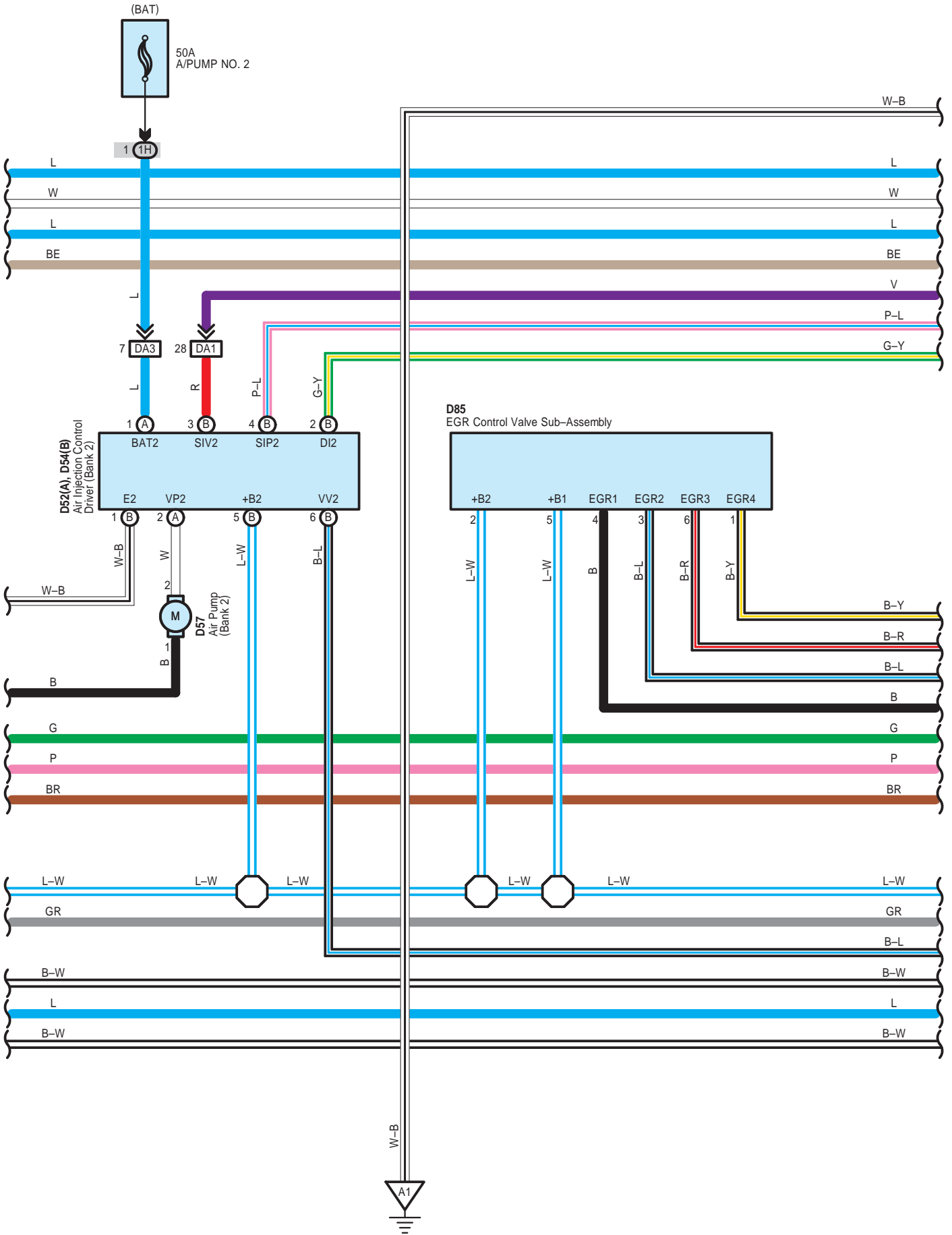

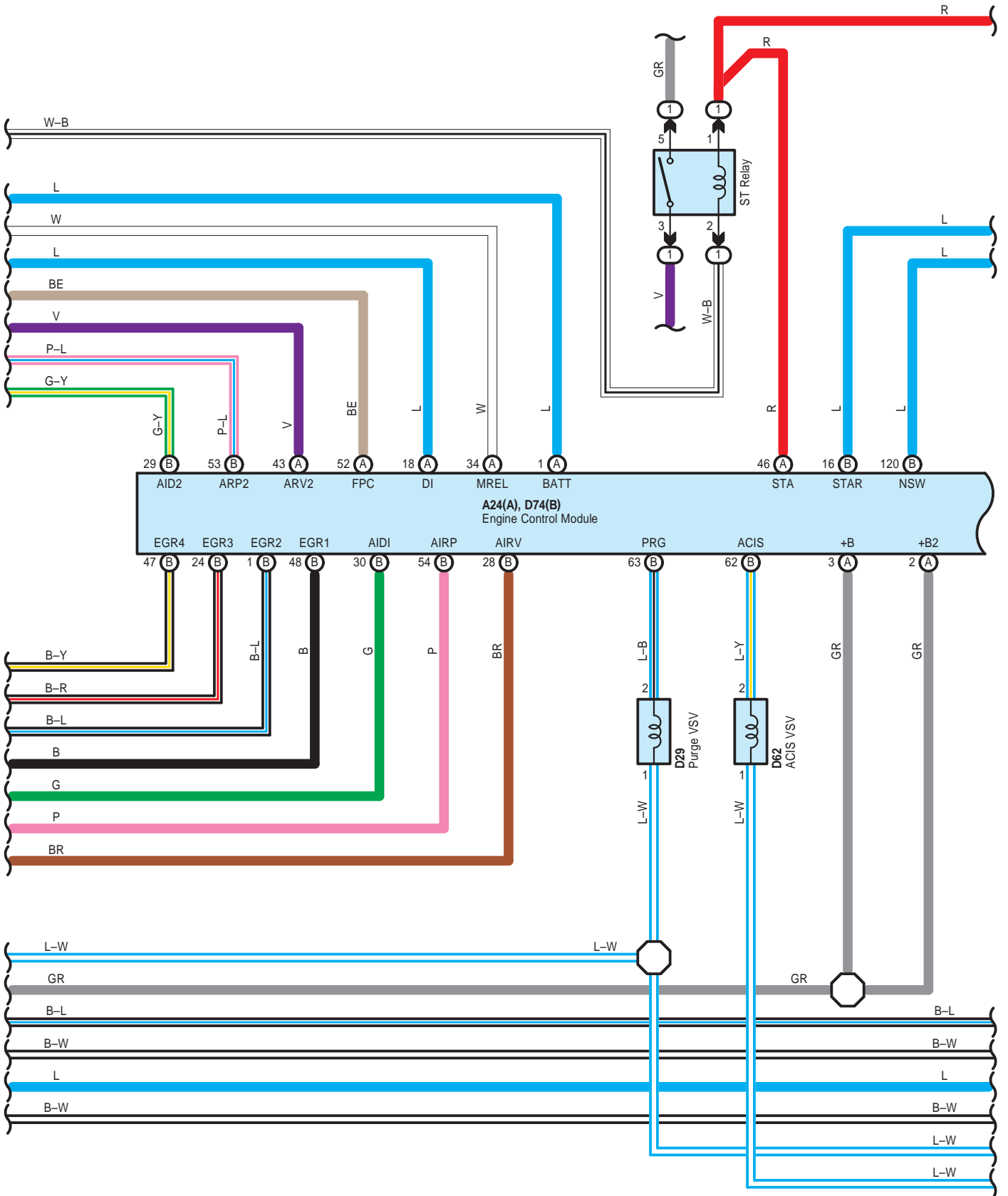

Engine Control <1UR-FE>

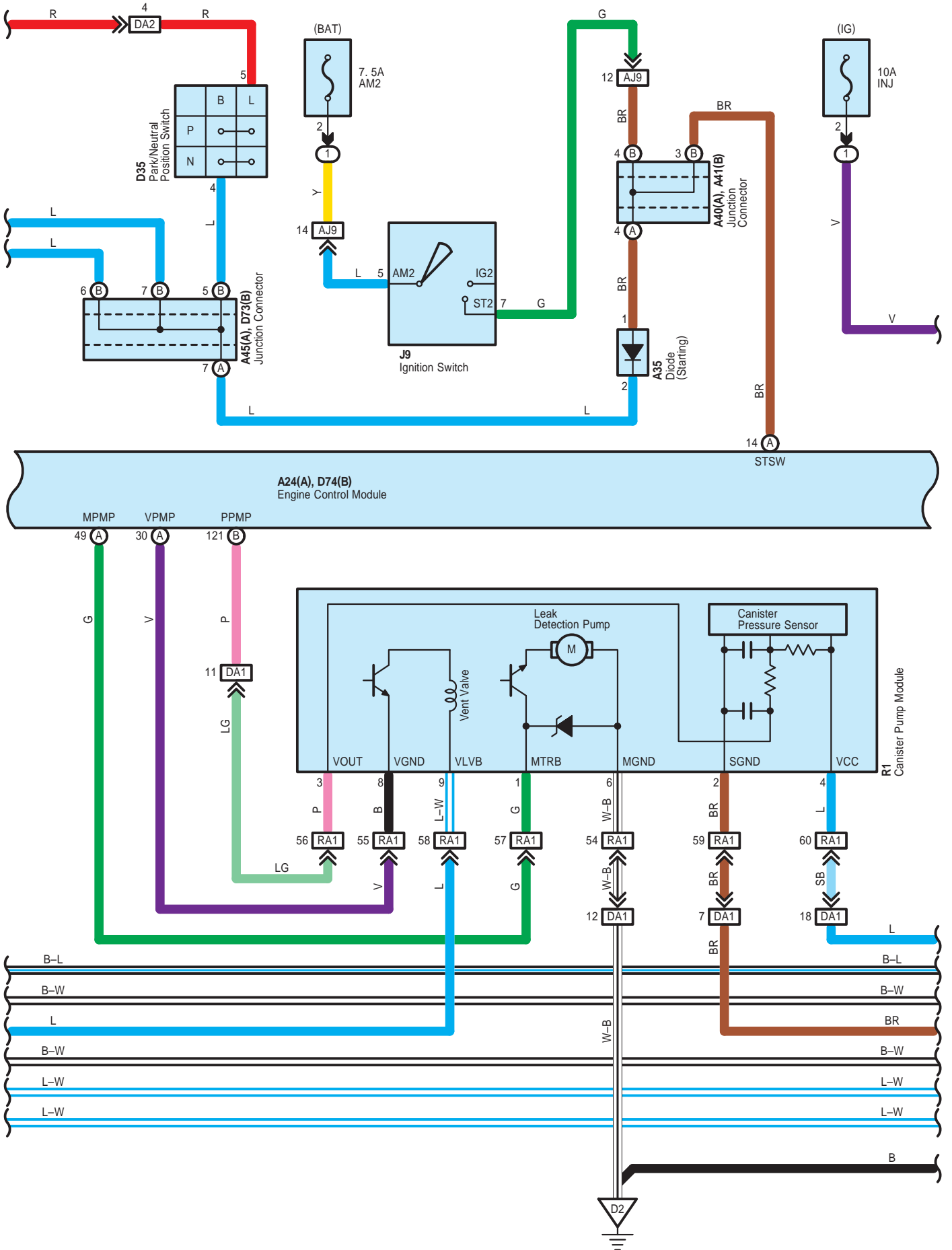

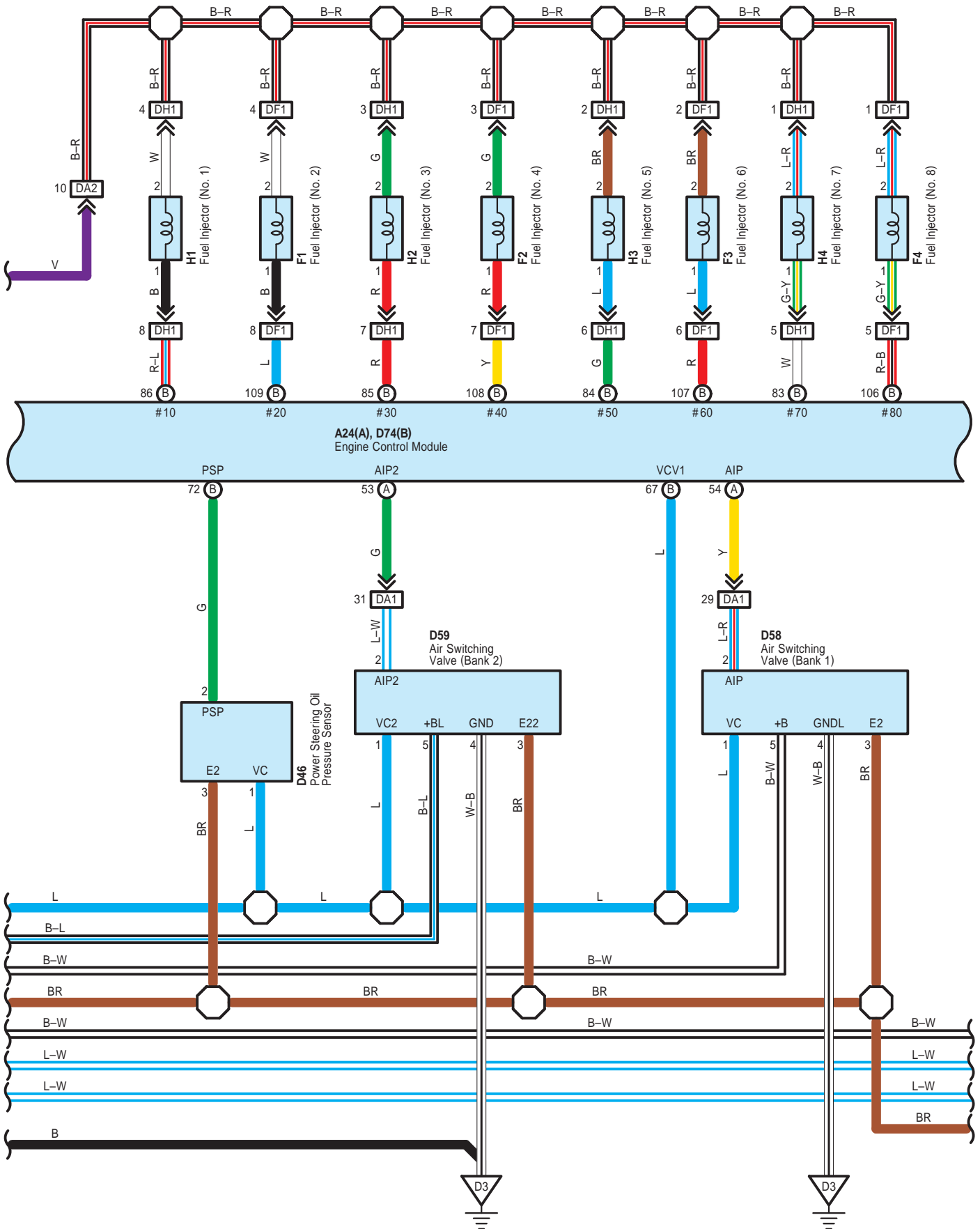

Engine Control <1UR-FE>

\* 1 : Shielded

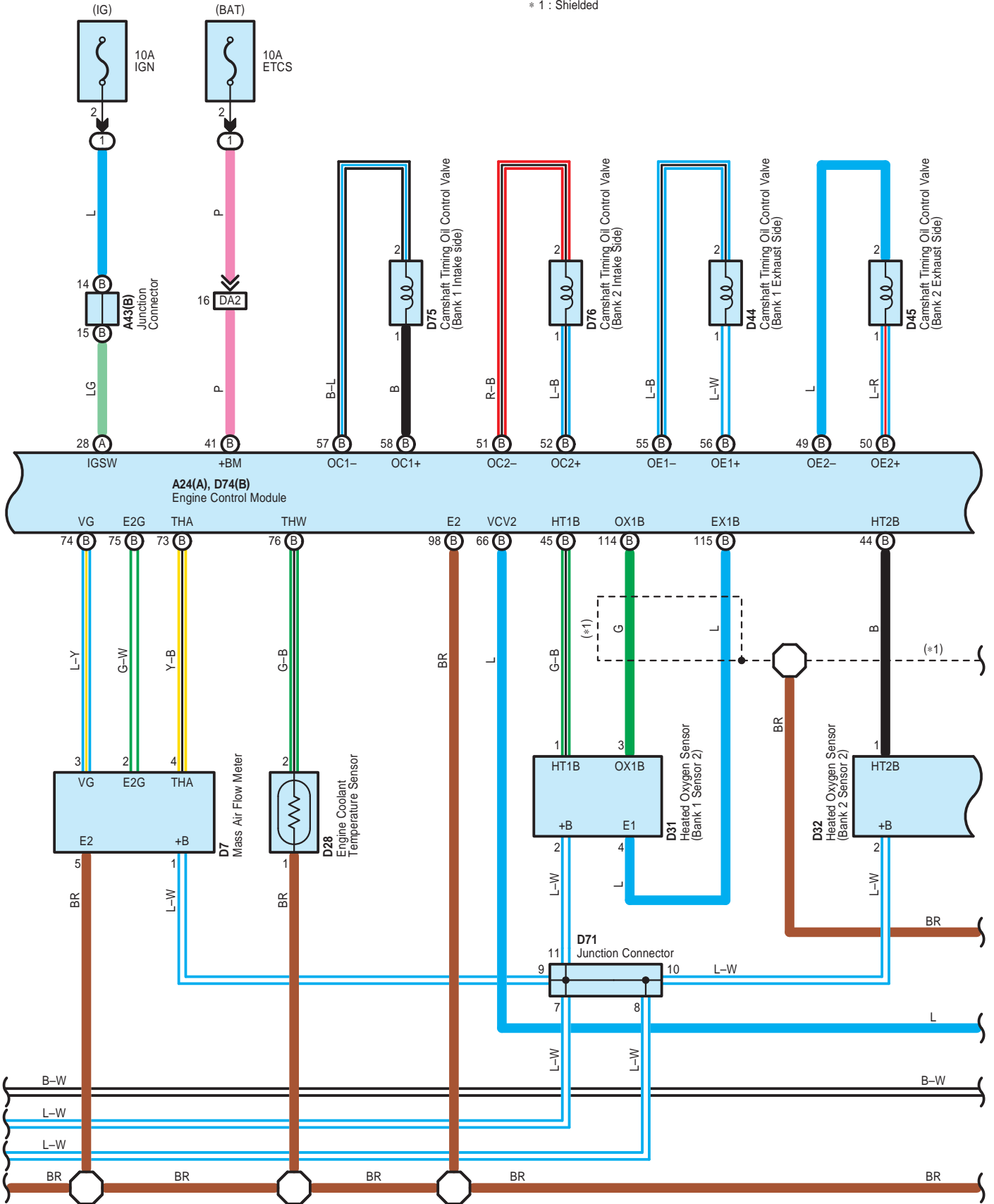



Engine Control <1UR-FE>

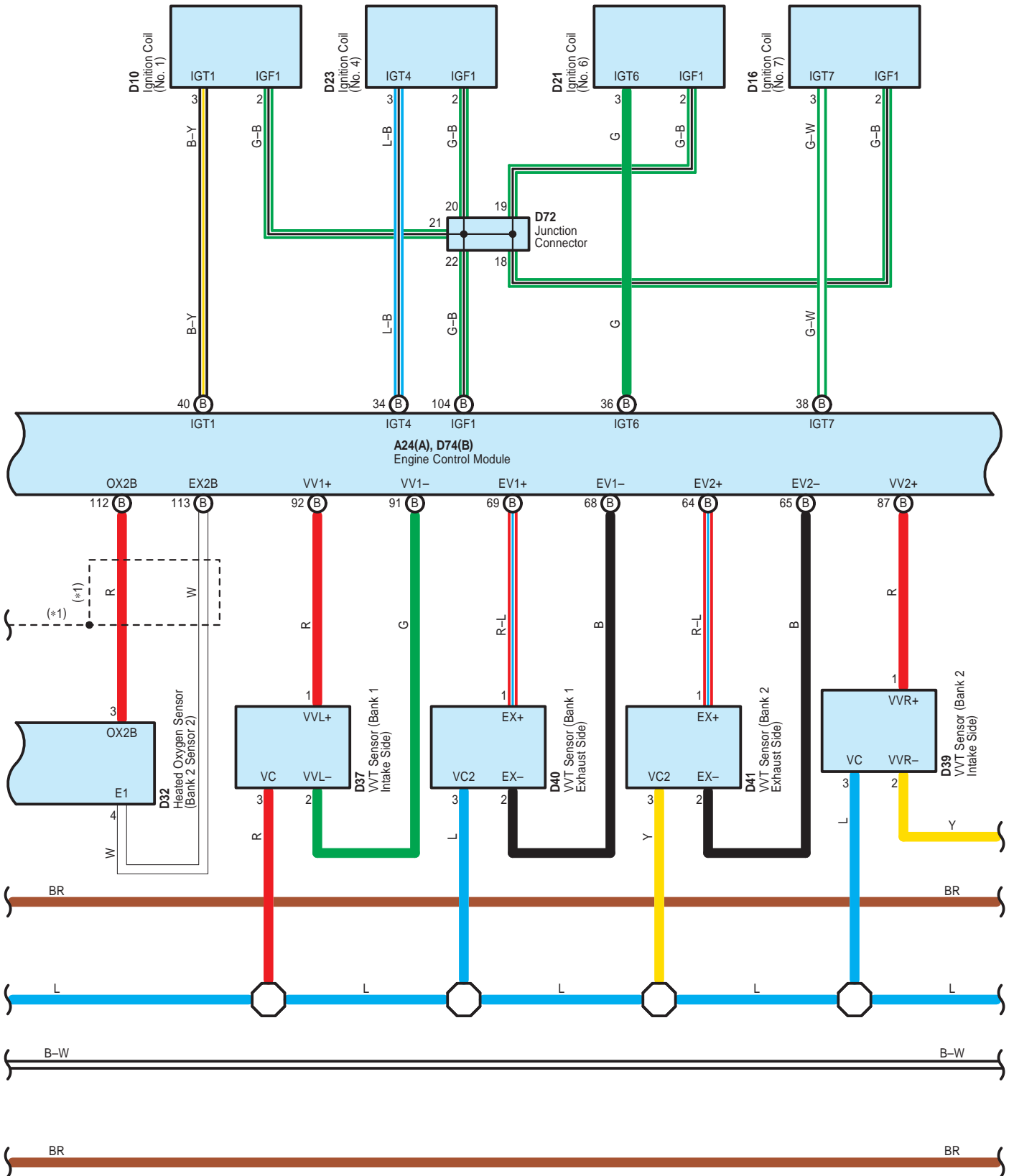

Engine Control <1UR-FE>

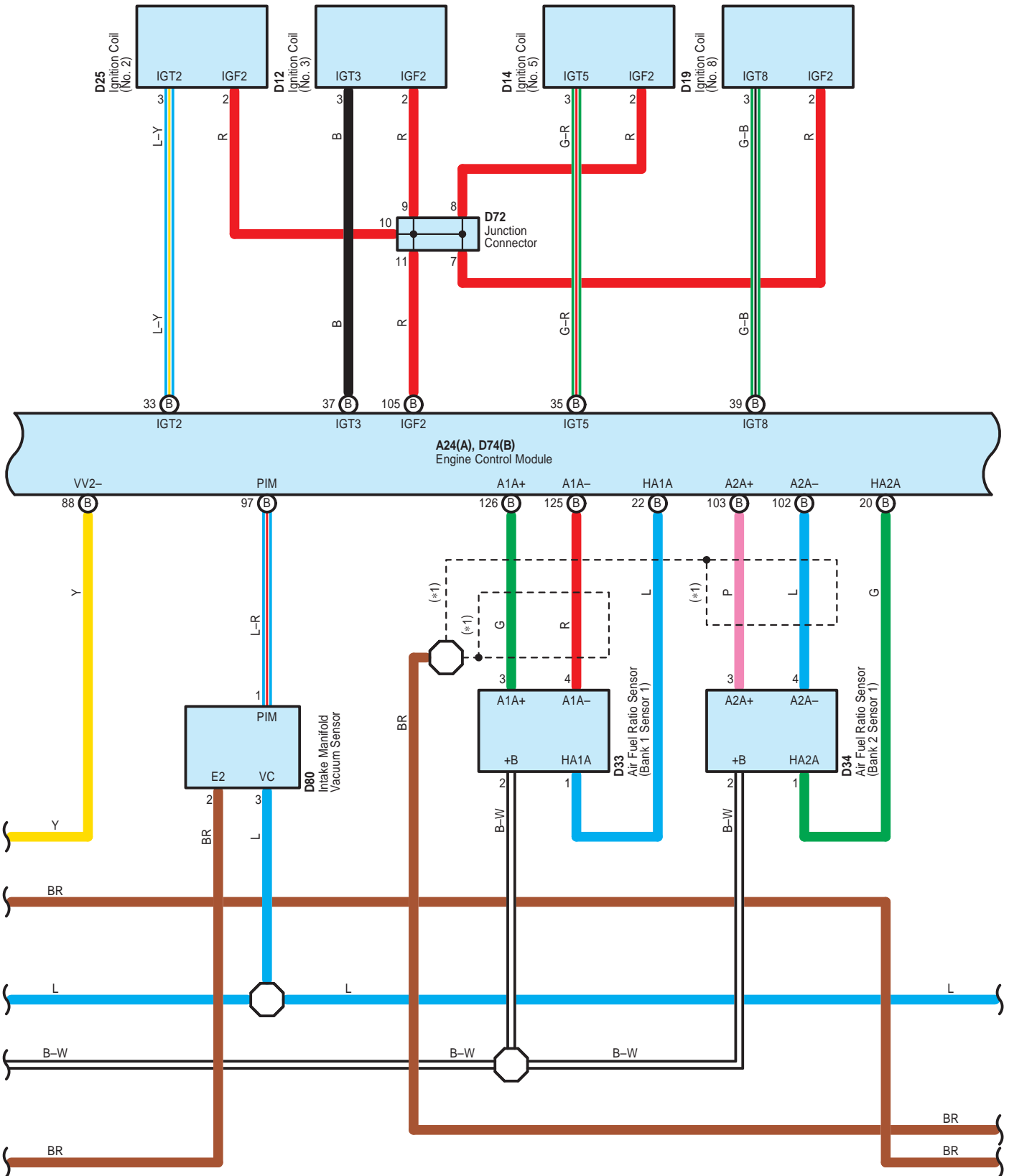

\* 1 : Shielded

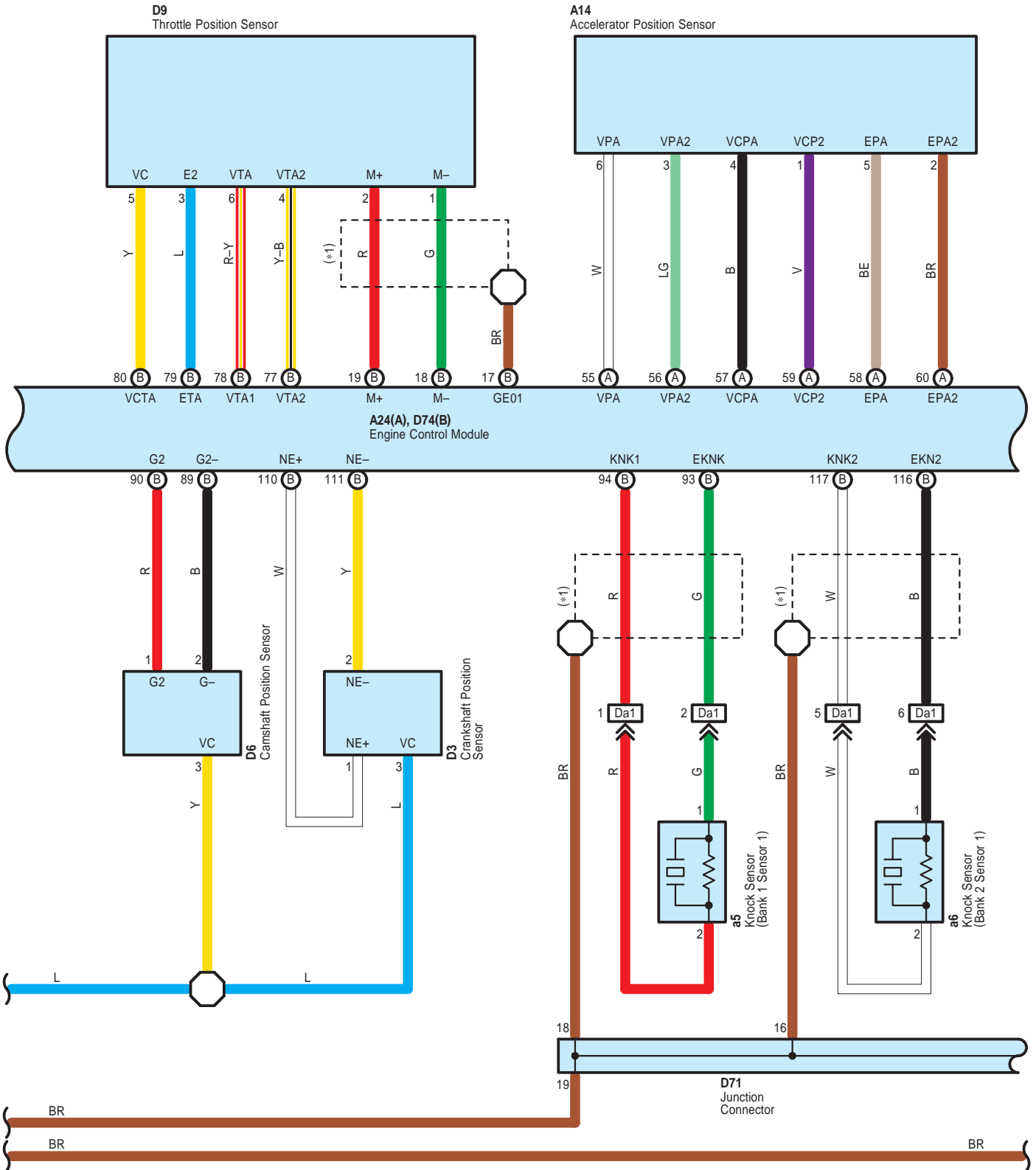

\* 1 : Shielded

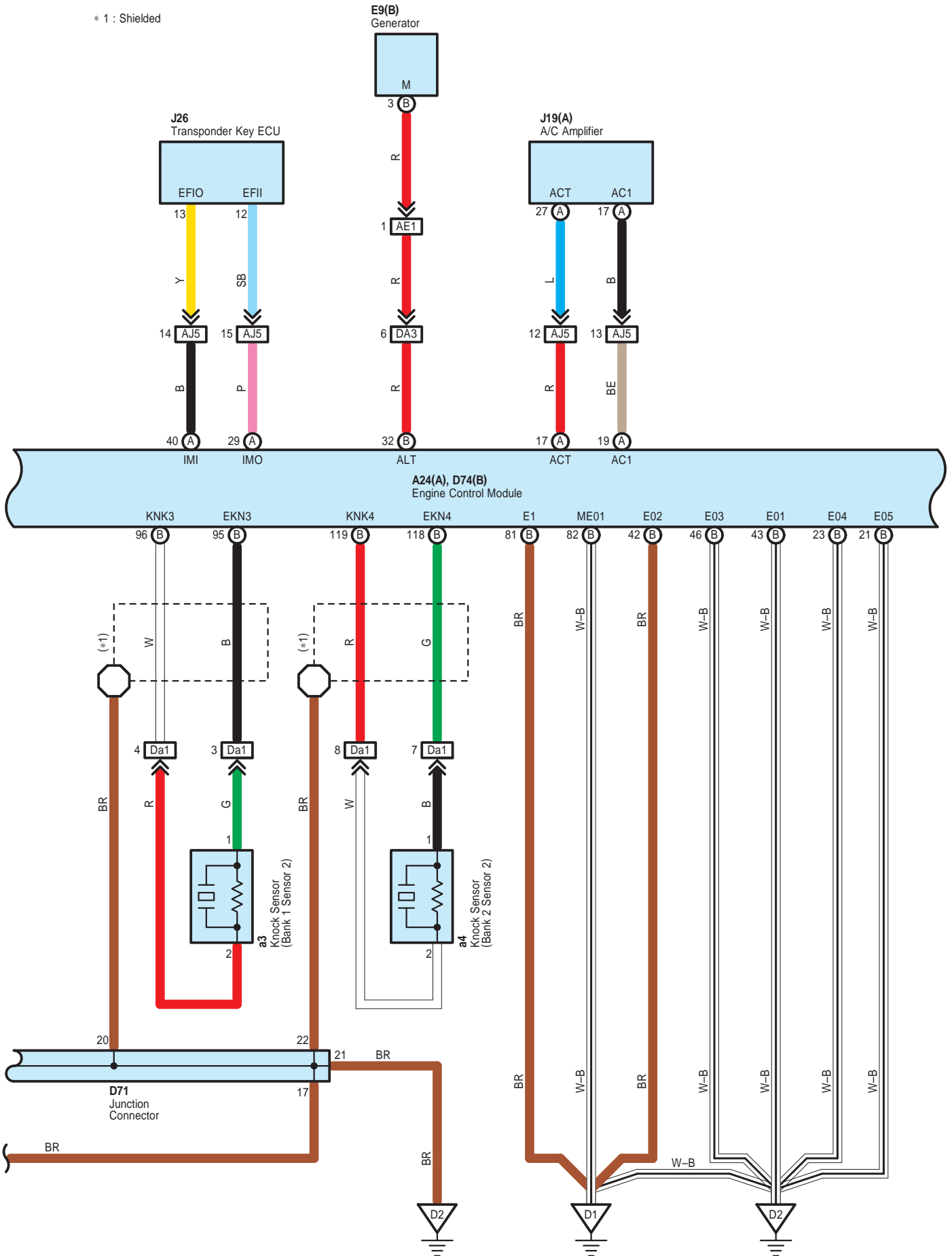

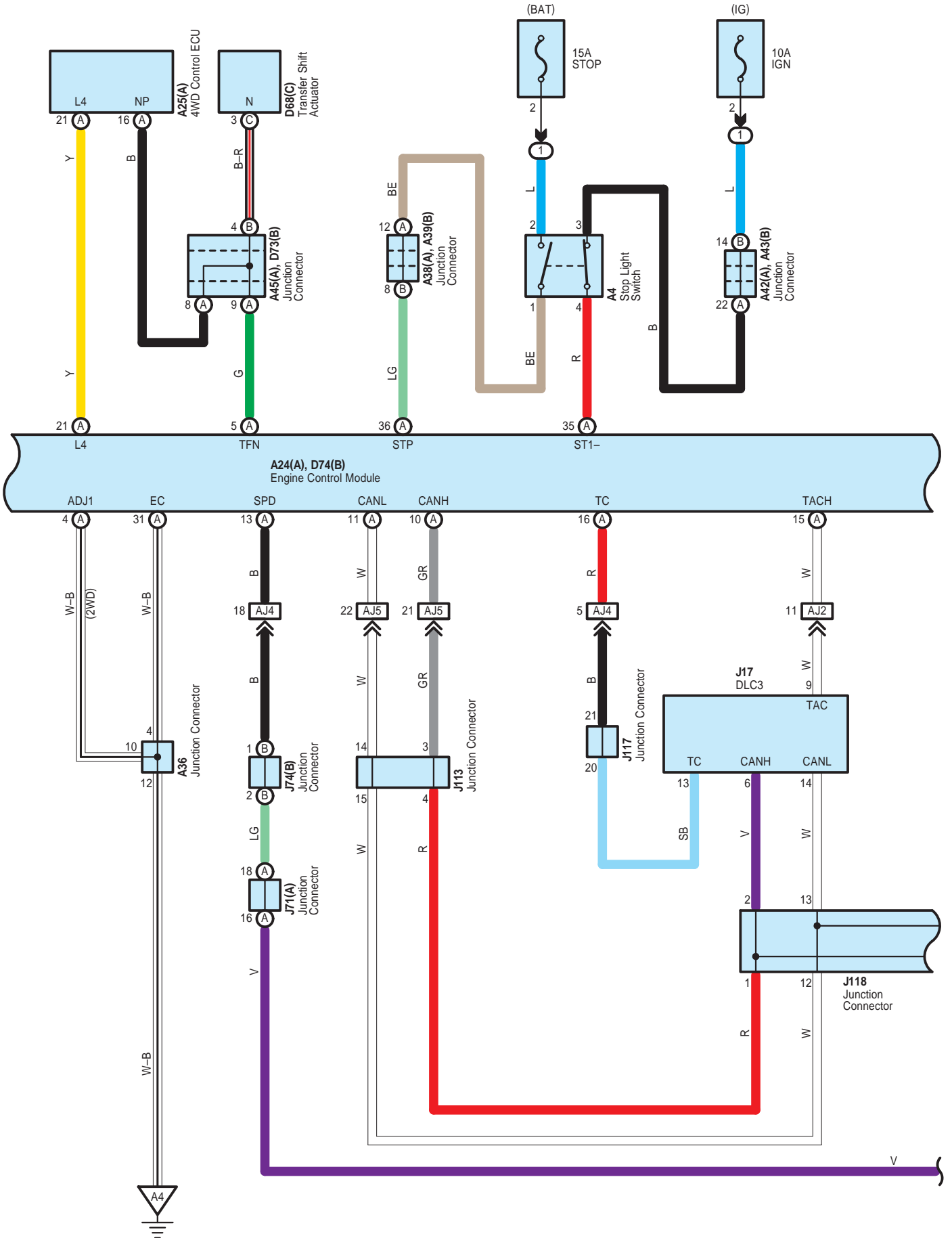

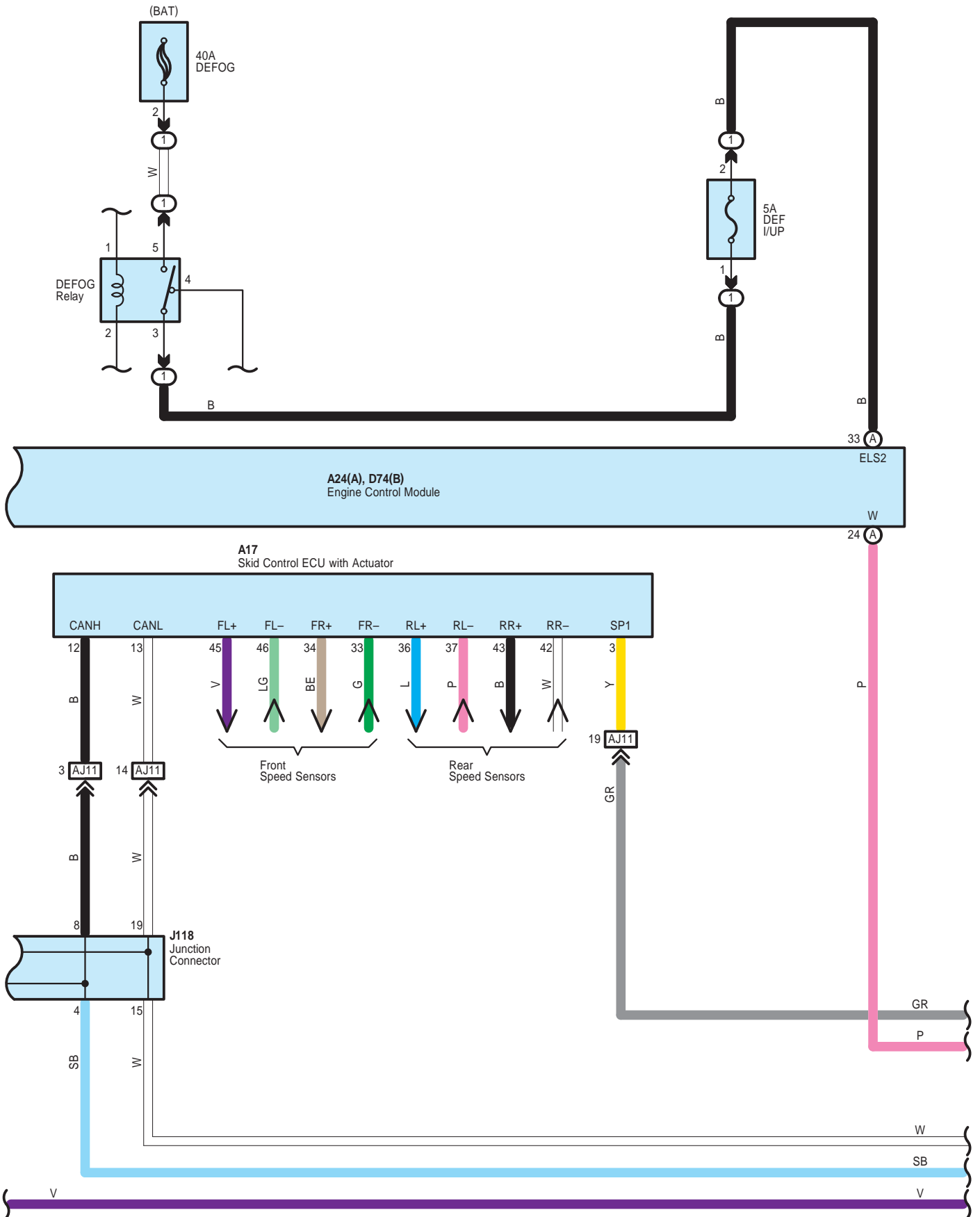

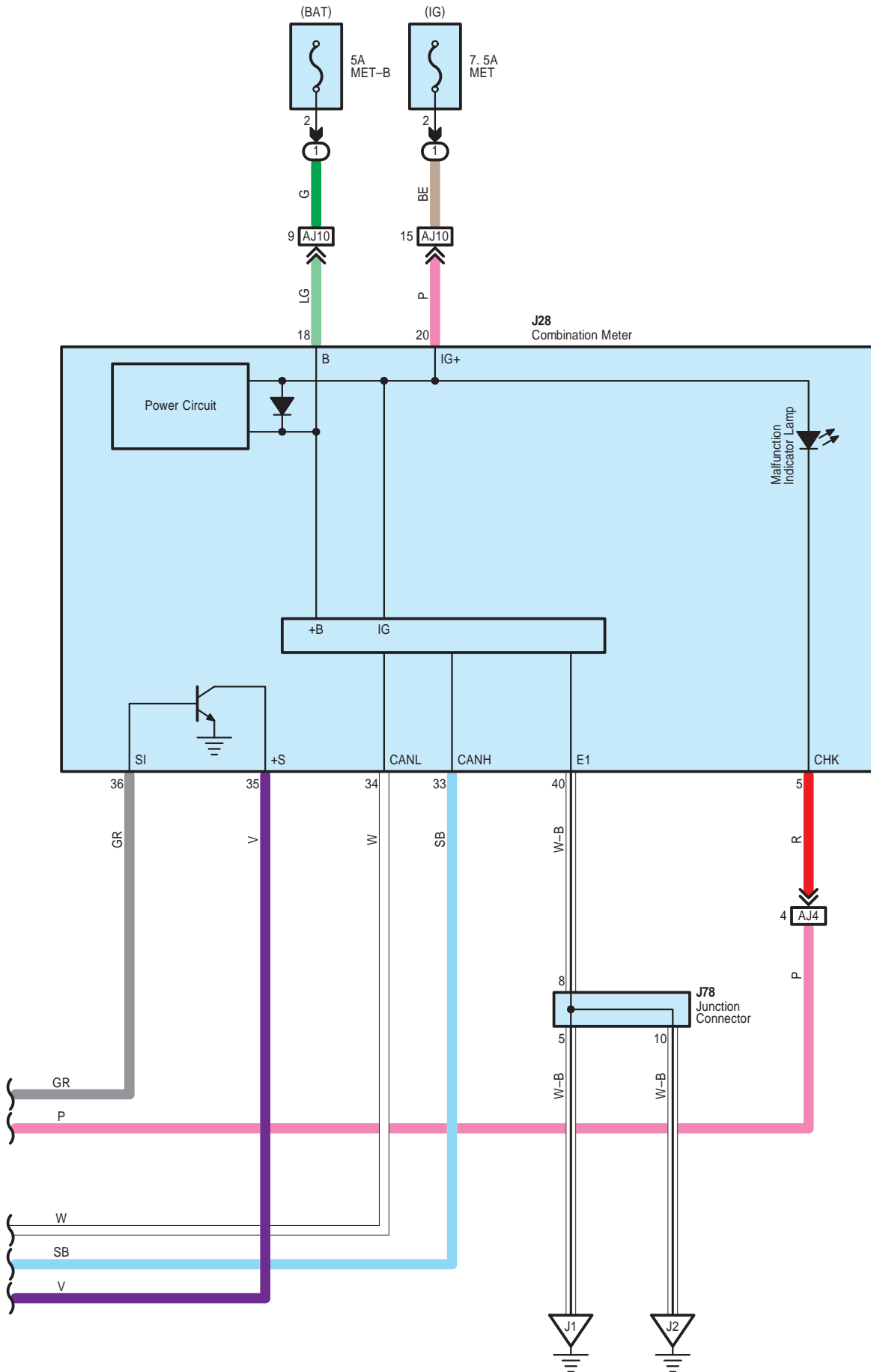

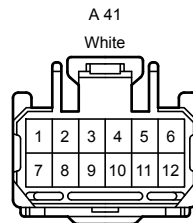
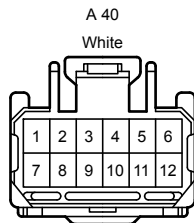
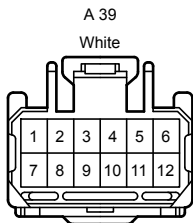
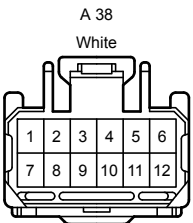
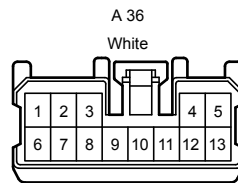
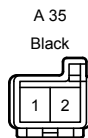
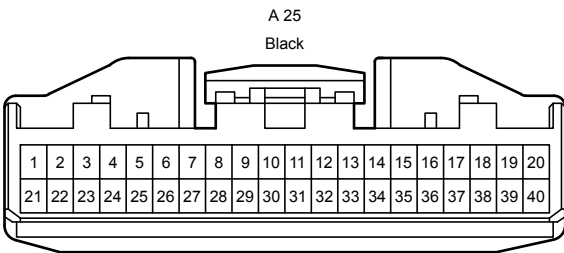
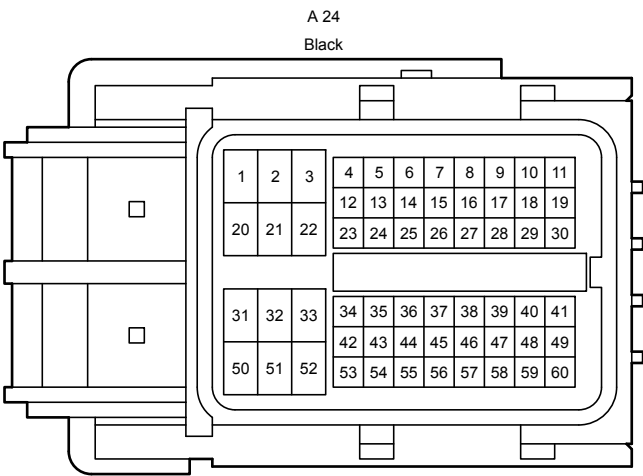
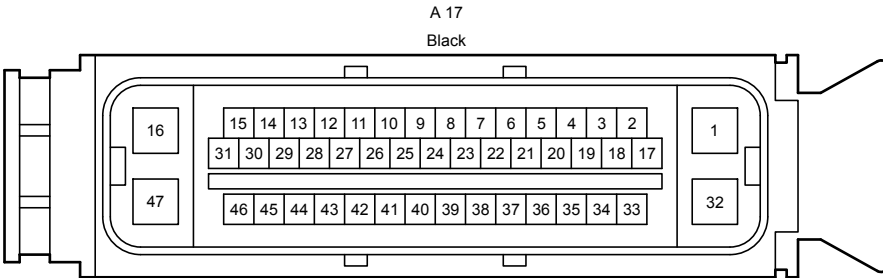
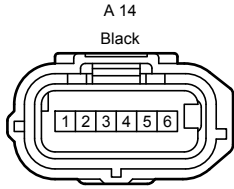
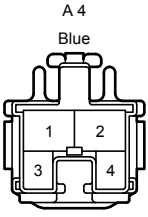



Engine Control <1UR-FE>

A 42  
White

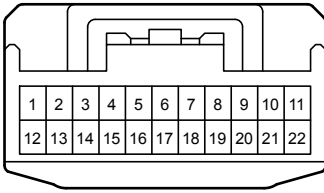

A 43  
White

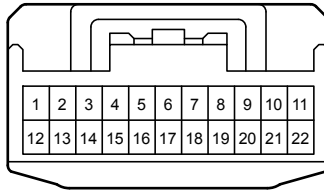

A 44  
White

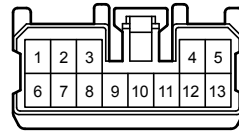

A 45  
Blue

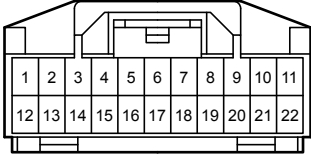

D 3  
Black

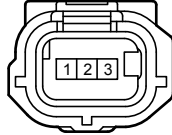

D 6  
Black

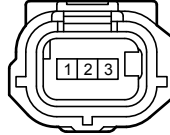

D 7  
Black

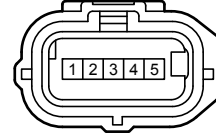

D 9  
Black

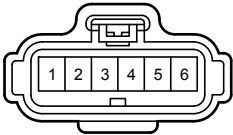

D 10  
Black

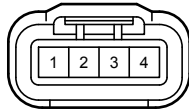

D 12  
Black

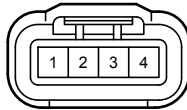

D 14  
Black

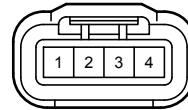

D 16  
Black

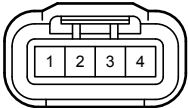

D 19  
Black

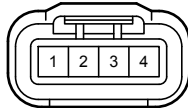

D 21  
Black

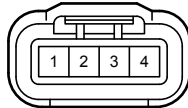

D 23  
Black

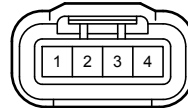

D 25  
Black

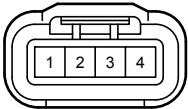

D 28  
Dark Gray



D 29  
Black

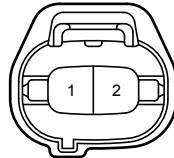

D 31  
Dark Gray



D 32  
Dark Gray



D 33  
Dark Gray



D 34  
Dark Gray



D 35  
Gray

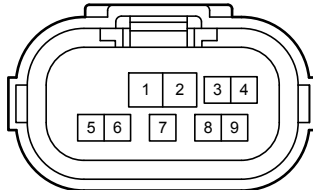

D 37  
Black

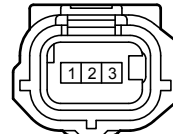

D 39  
Black

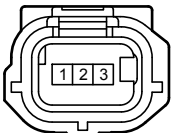

D 40  
Black

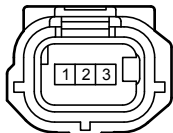

D 41  
Black

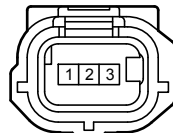

D 44  
Black



D 45  
Black



Engine Control <1UR-FE>

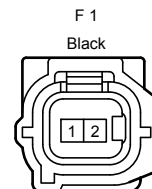
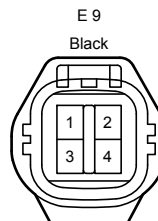
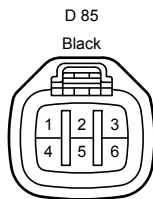
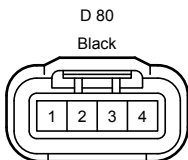
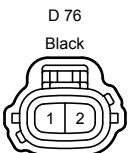
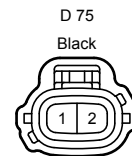
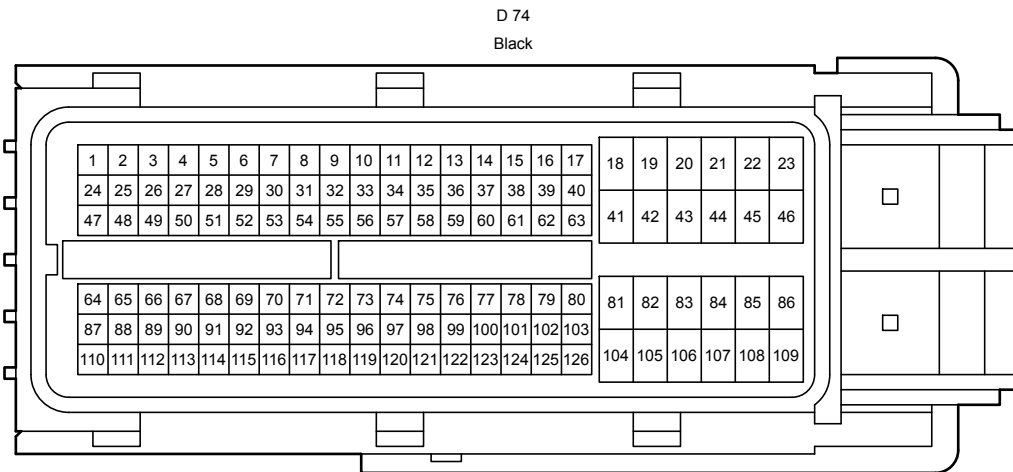
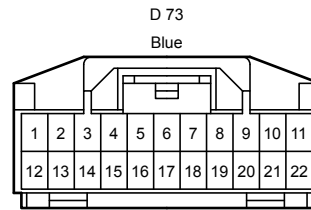
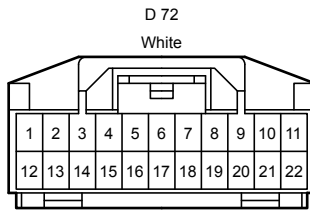
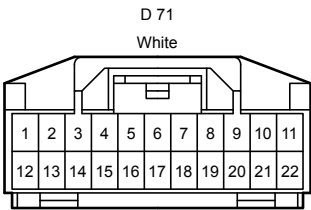
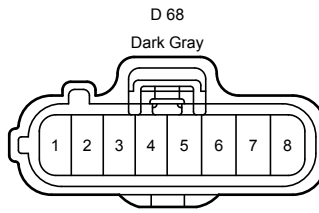
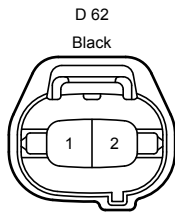
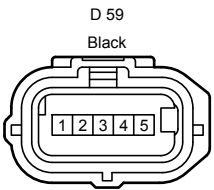
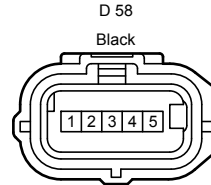
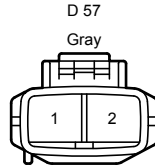
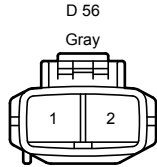
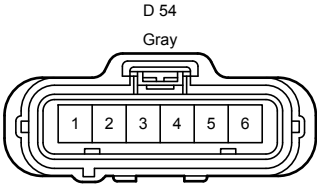
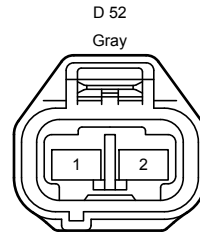
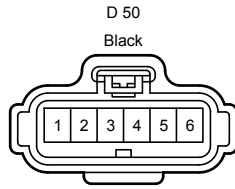
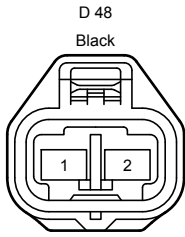
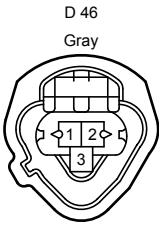

Engine Control <1UR-FE>

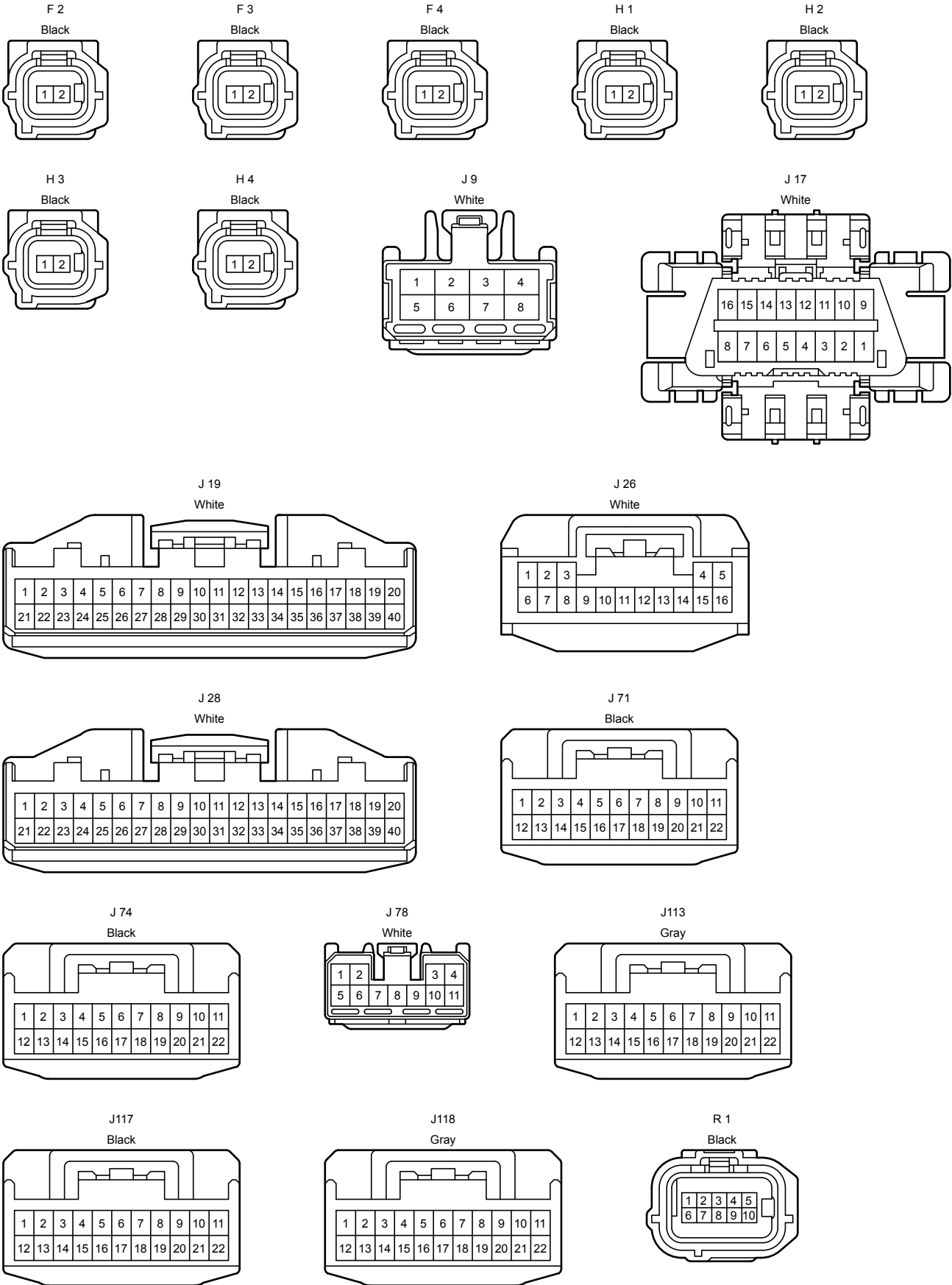

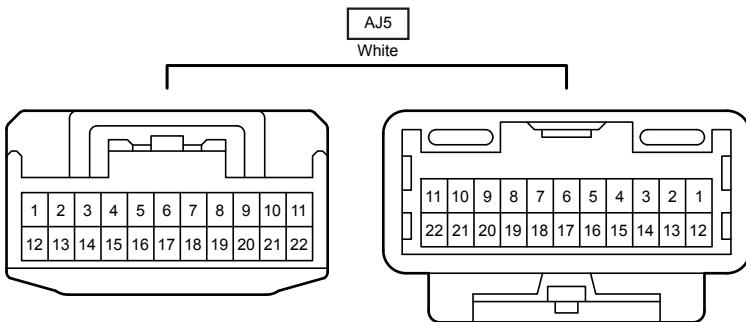
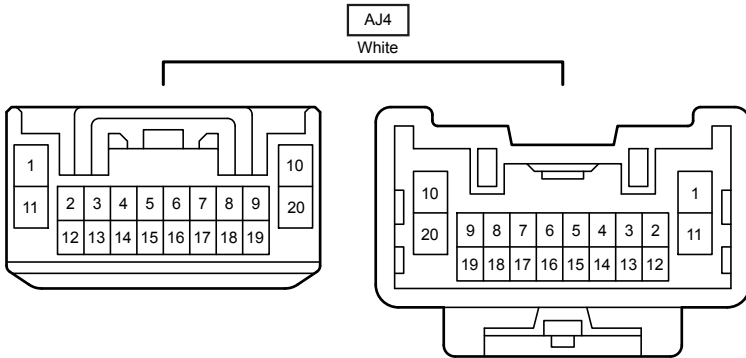
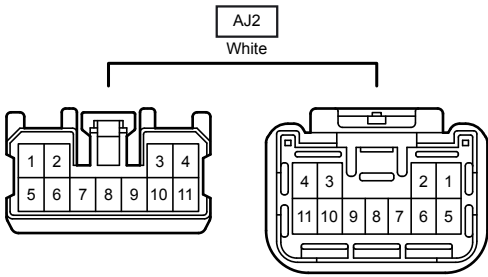
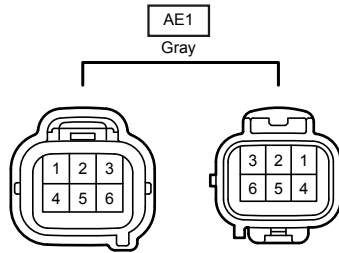
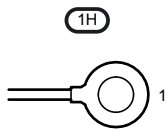
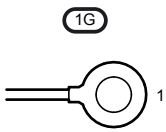
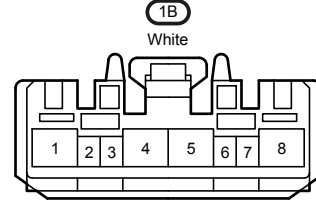
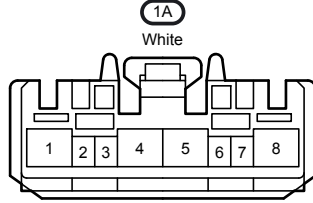
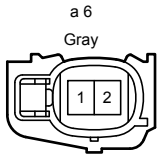
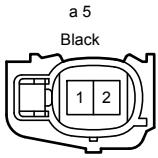
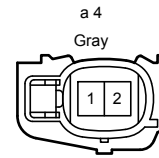
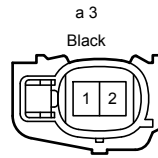
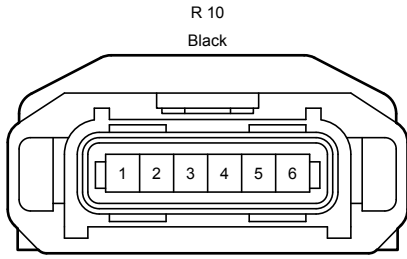
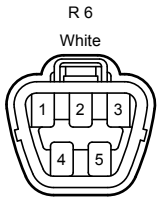

AJ9  
Gray

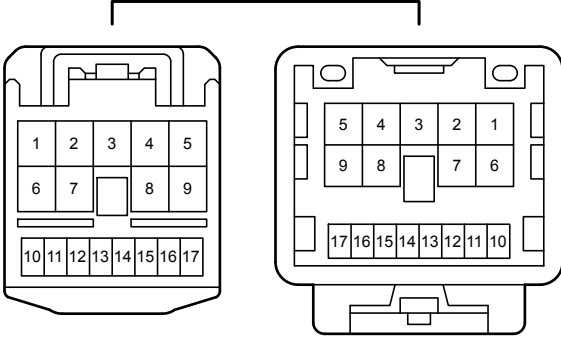

AJ10  
Gray

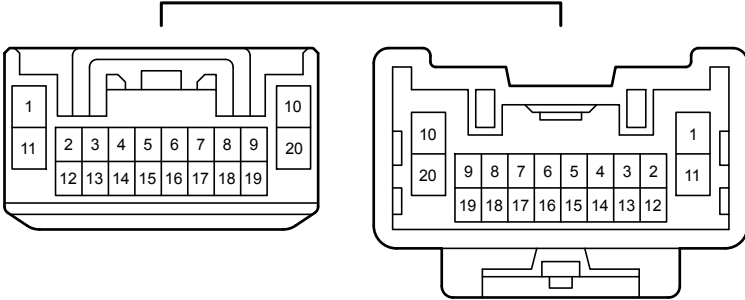

AJ11  
Gray

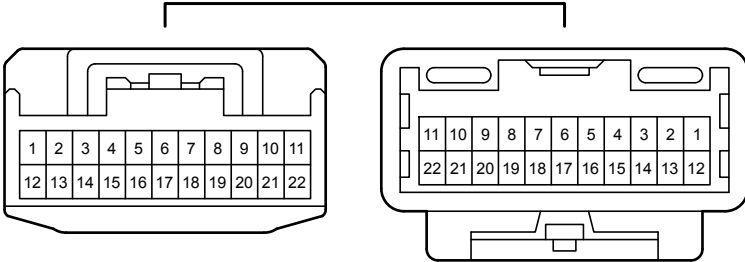

DA1  
White

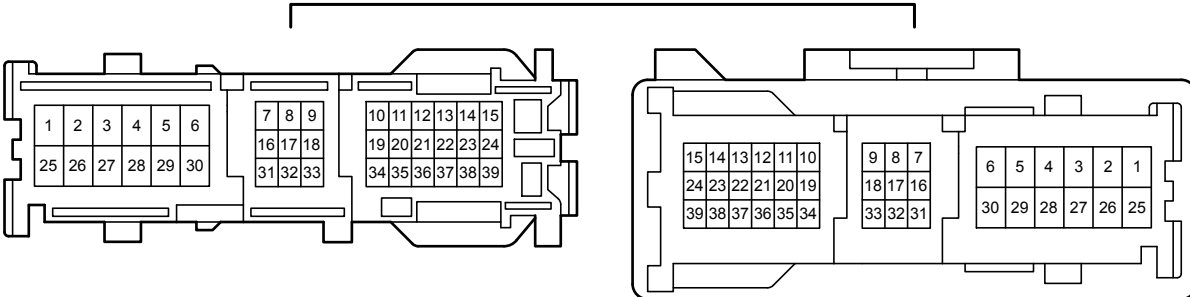



Engine Control <3UR-FE, 3UR-FBE>

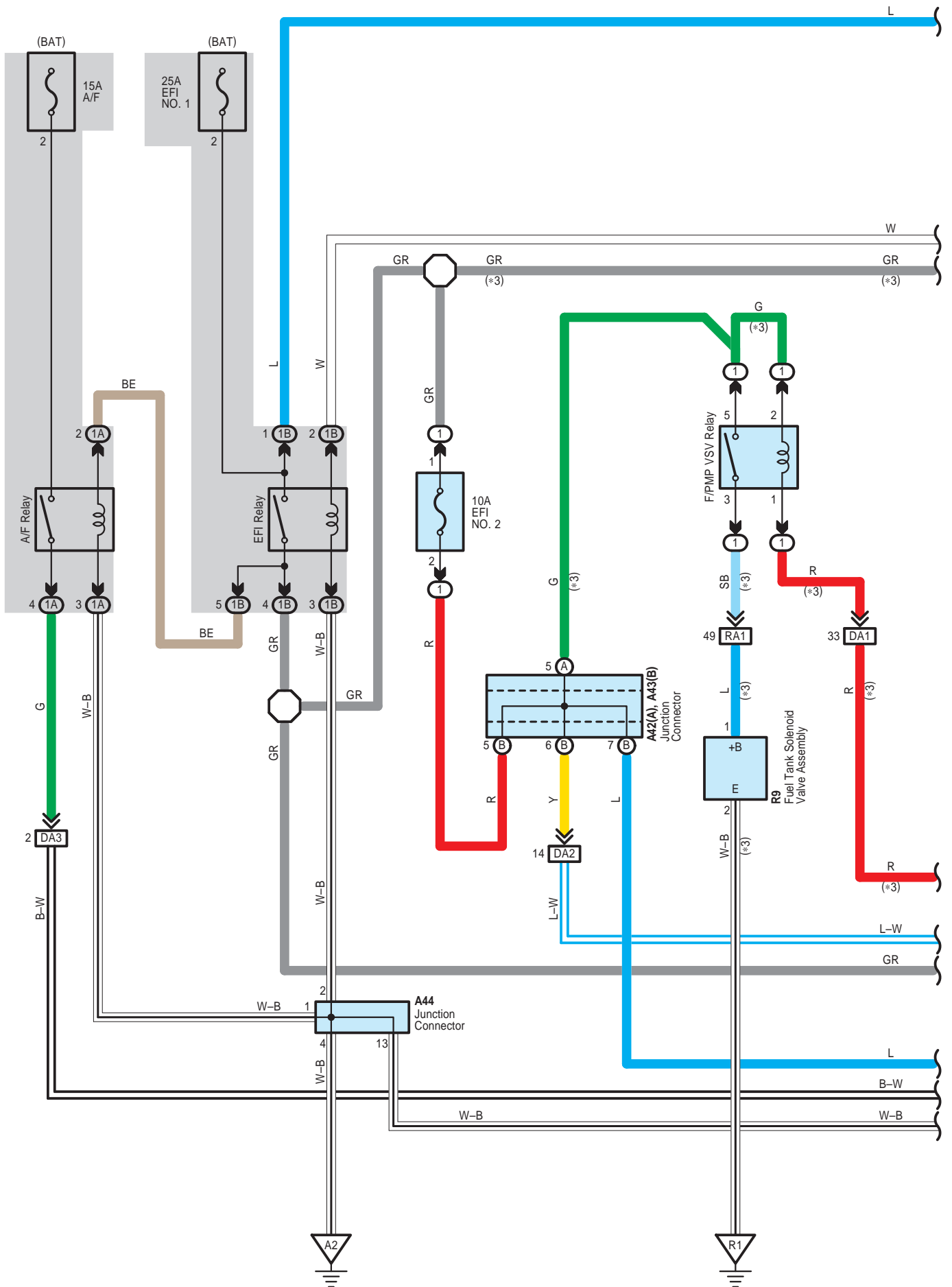

Engine Control <3UR-FE, 3UR-FBE>

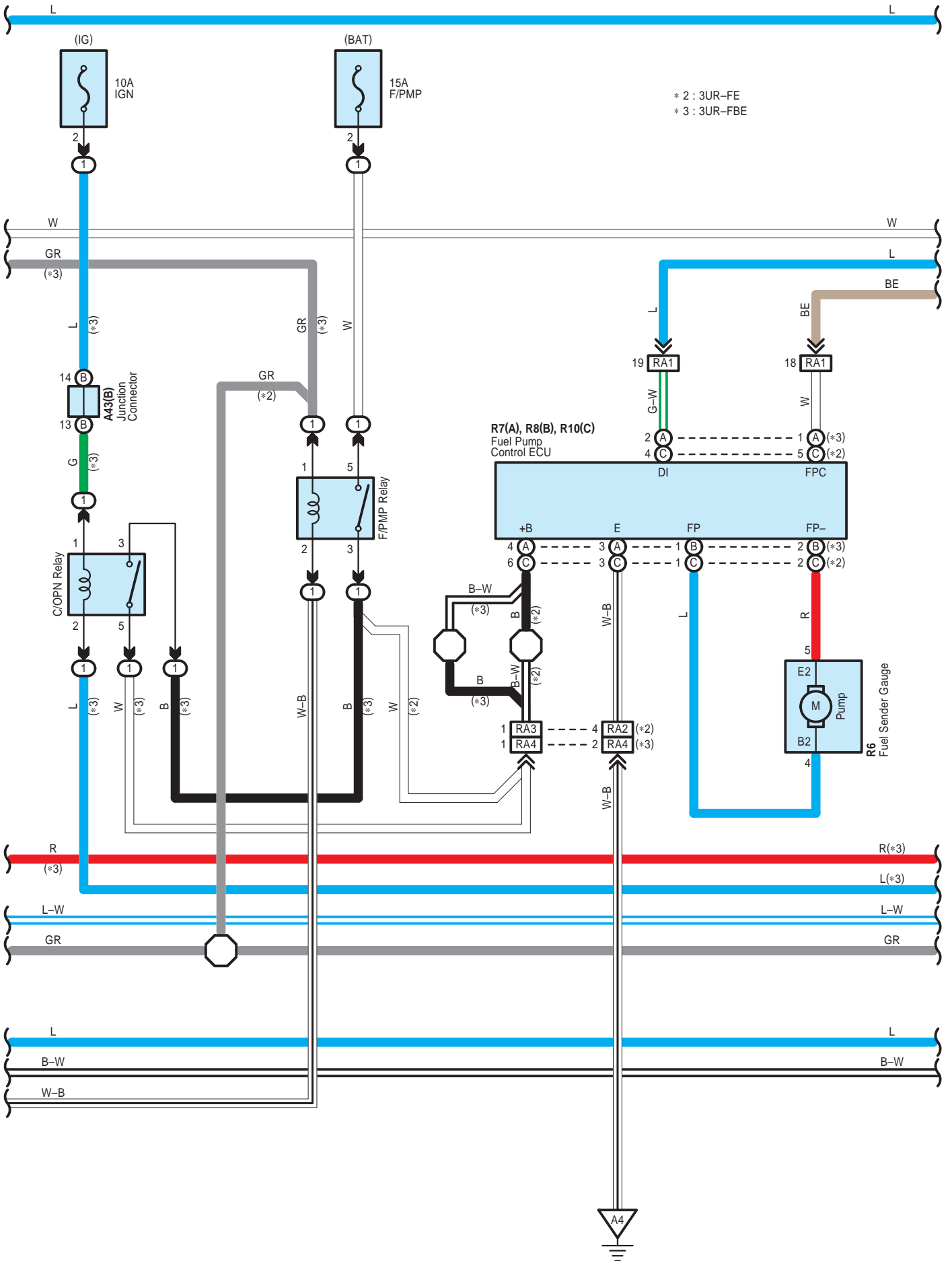



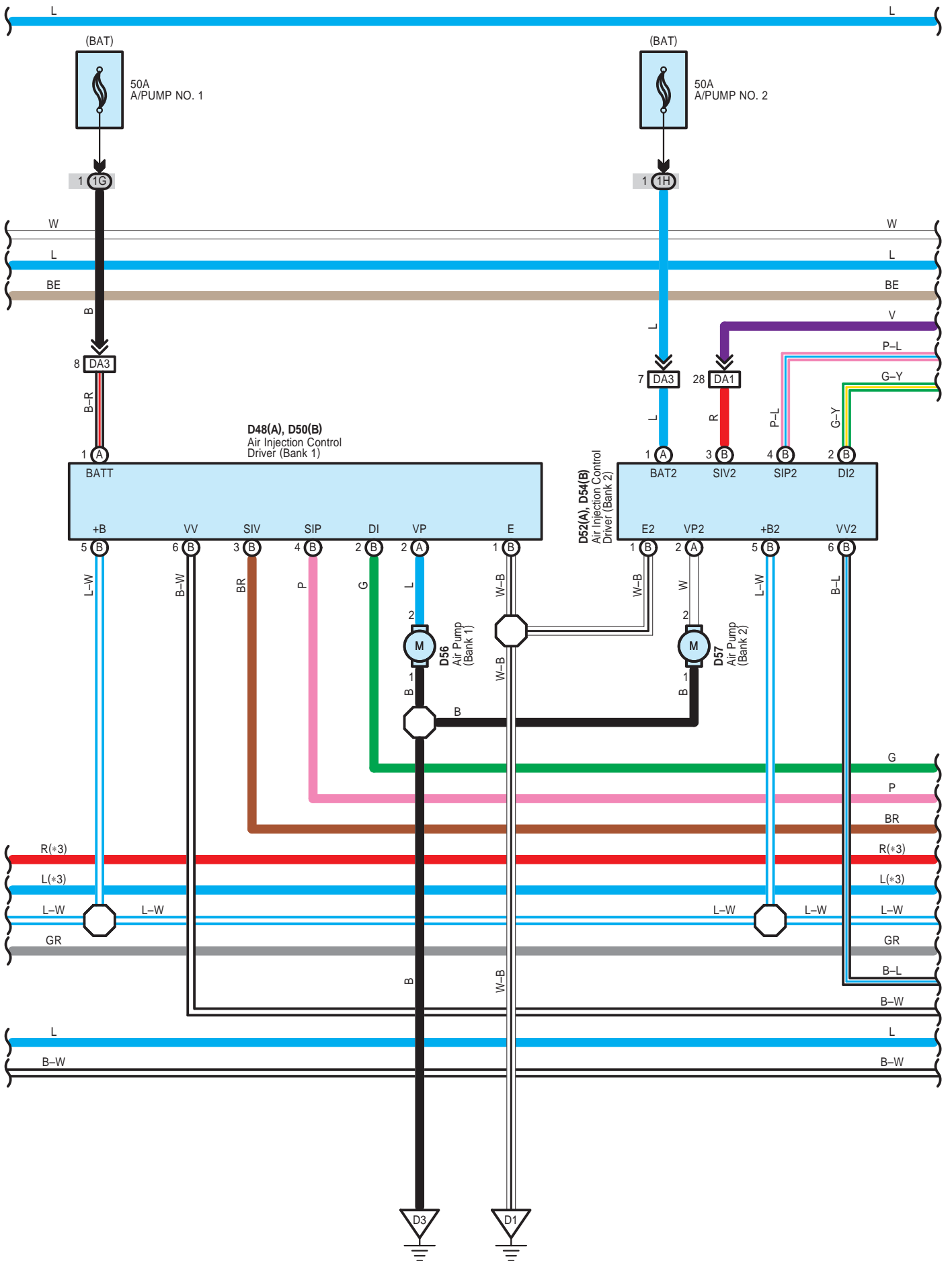



Engine Control <3UR-FE, 3UR-FBE>

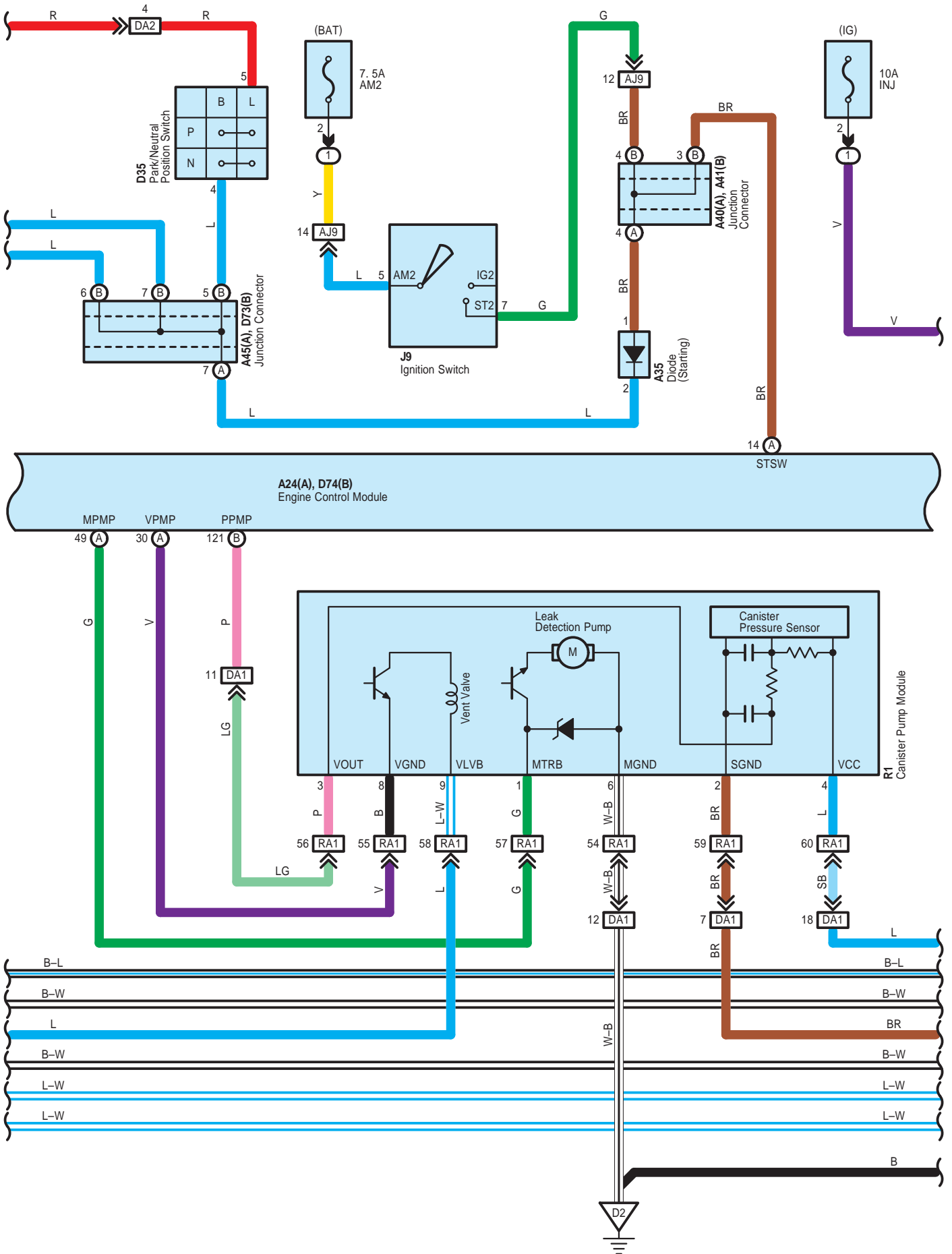

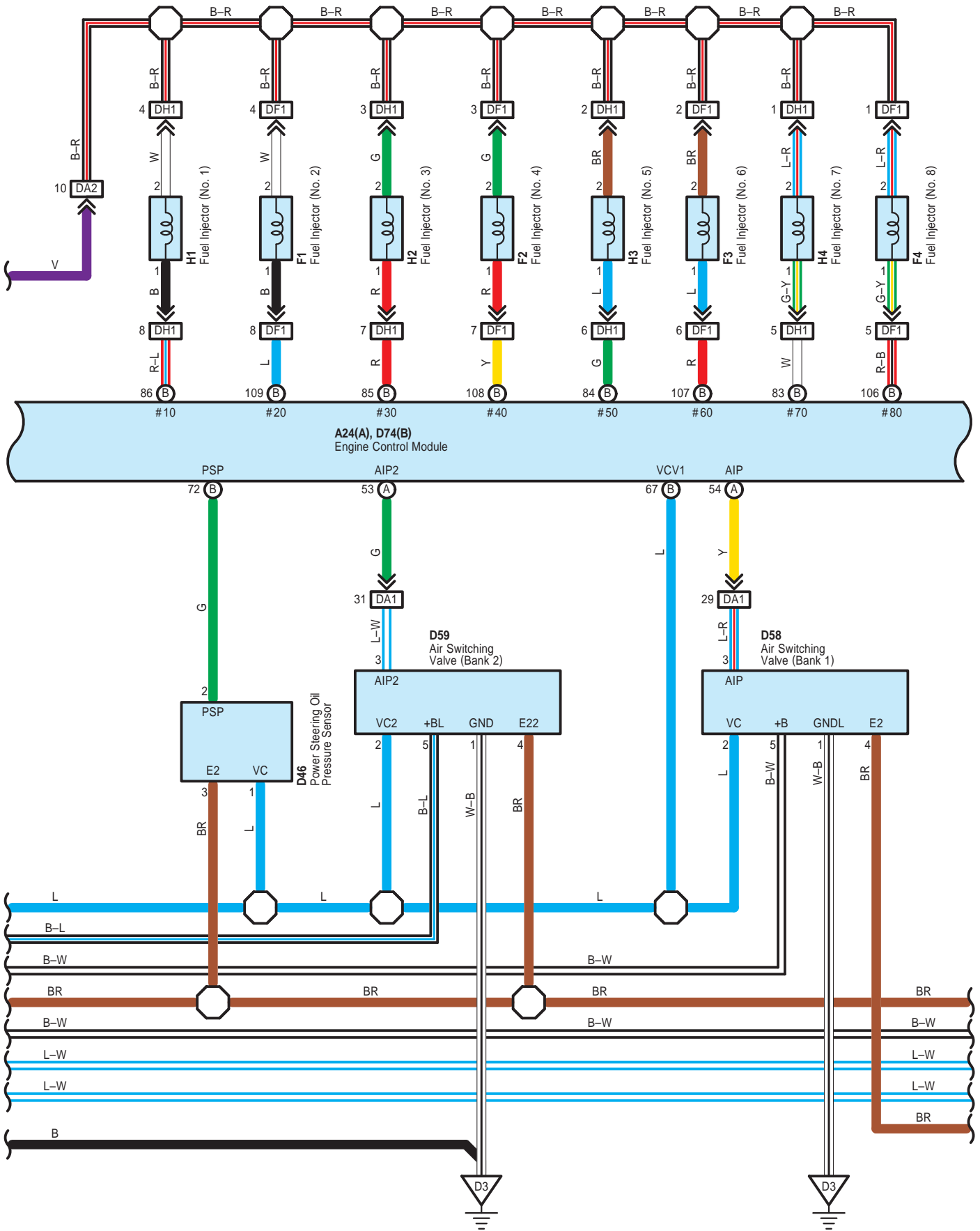

Engine Control <3UR-FE, 3UR-FBE>

\* 1 : Shielded

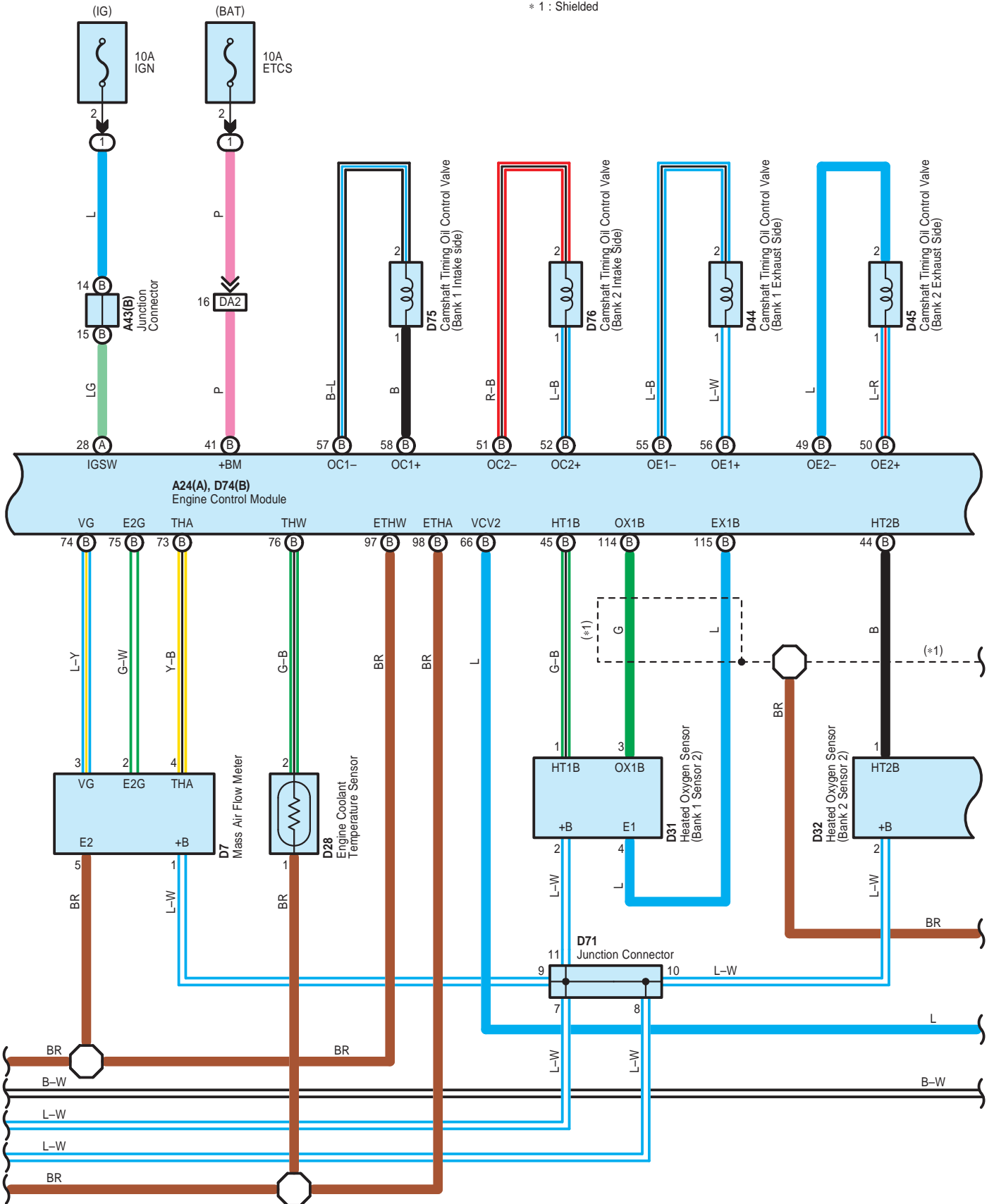

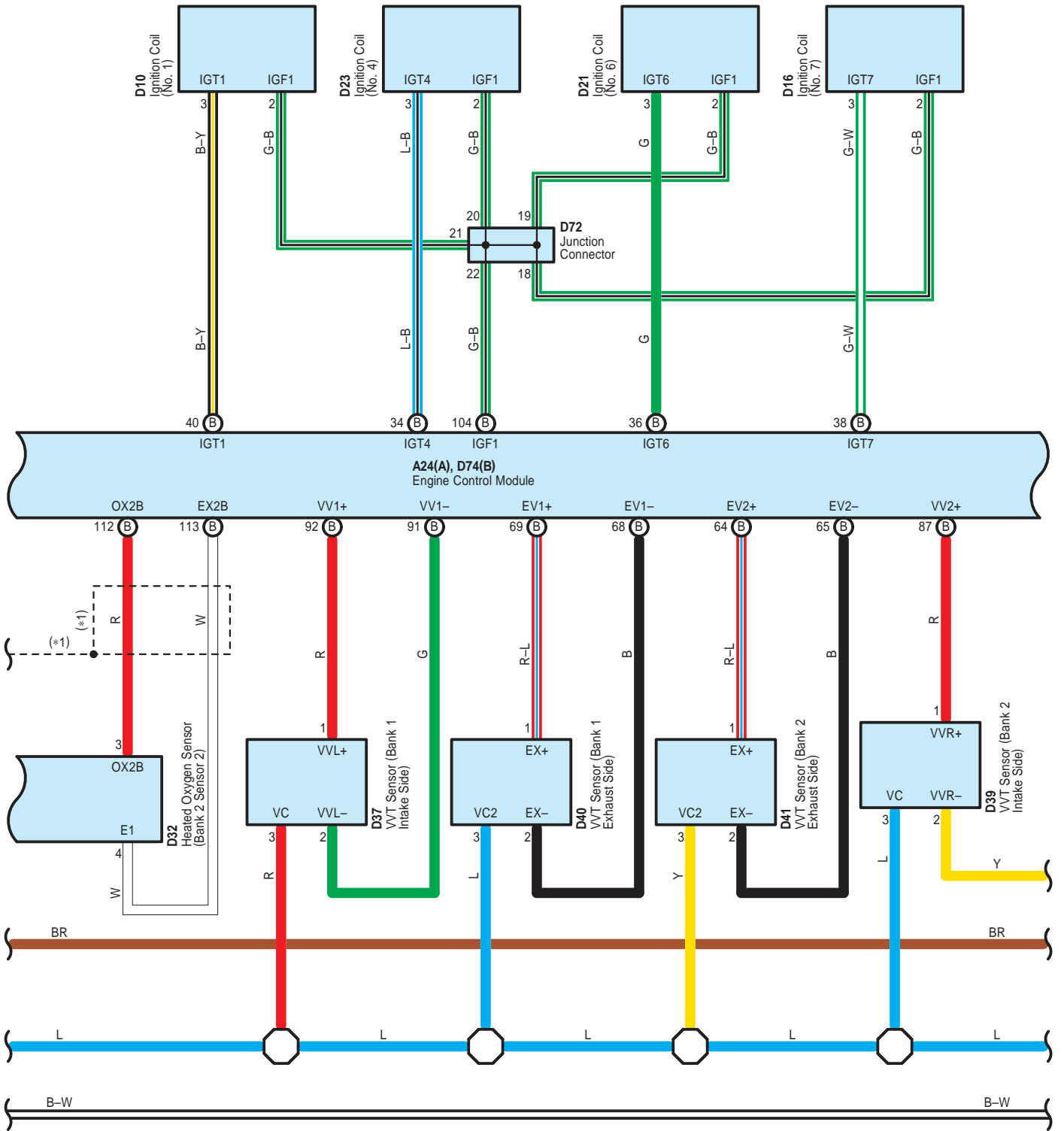

Engine Control <3UR-FE, 3UR-FBE>

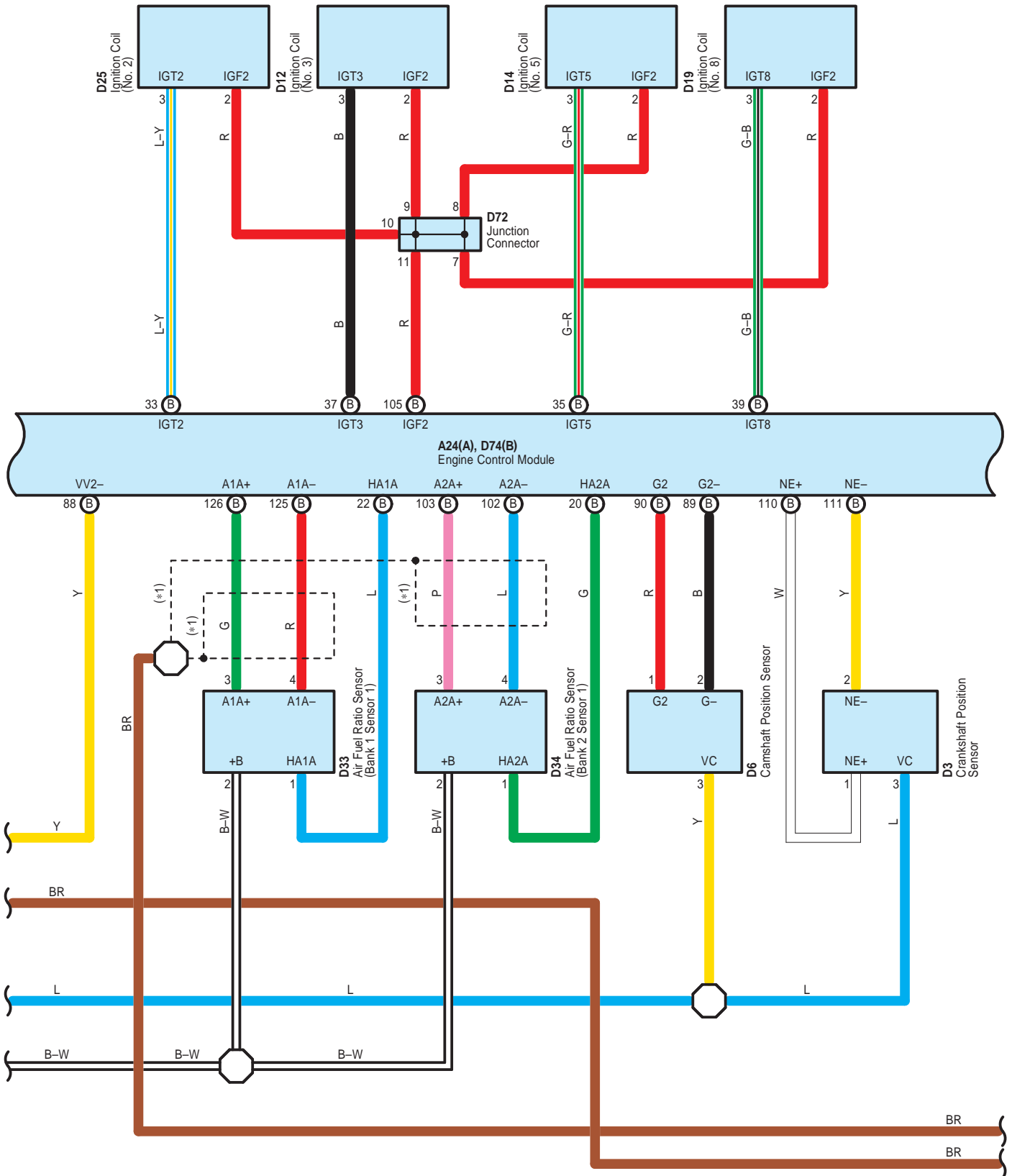

\* 1 : Shielded

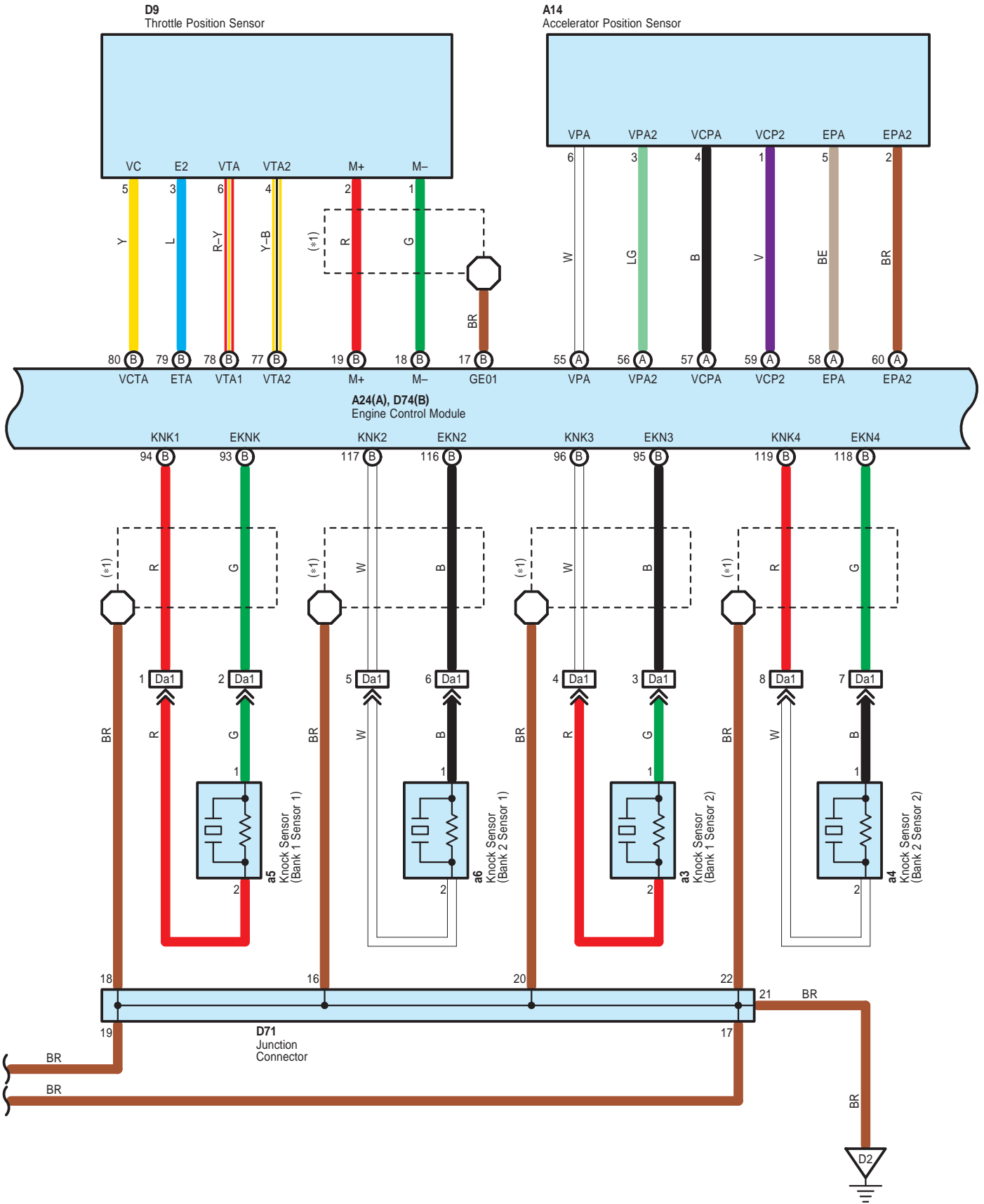



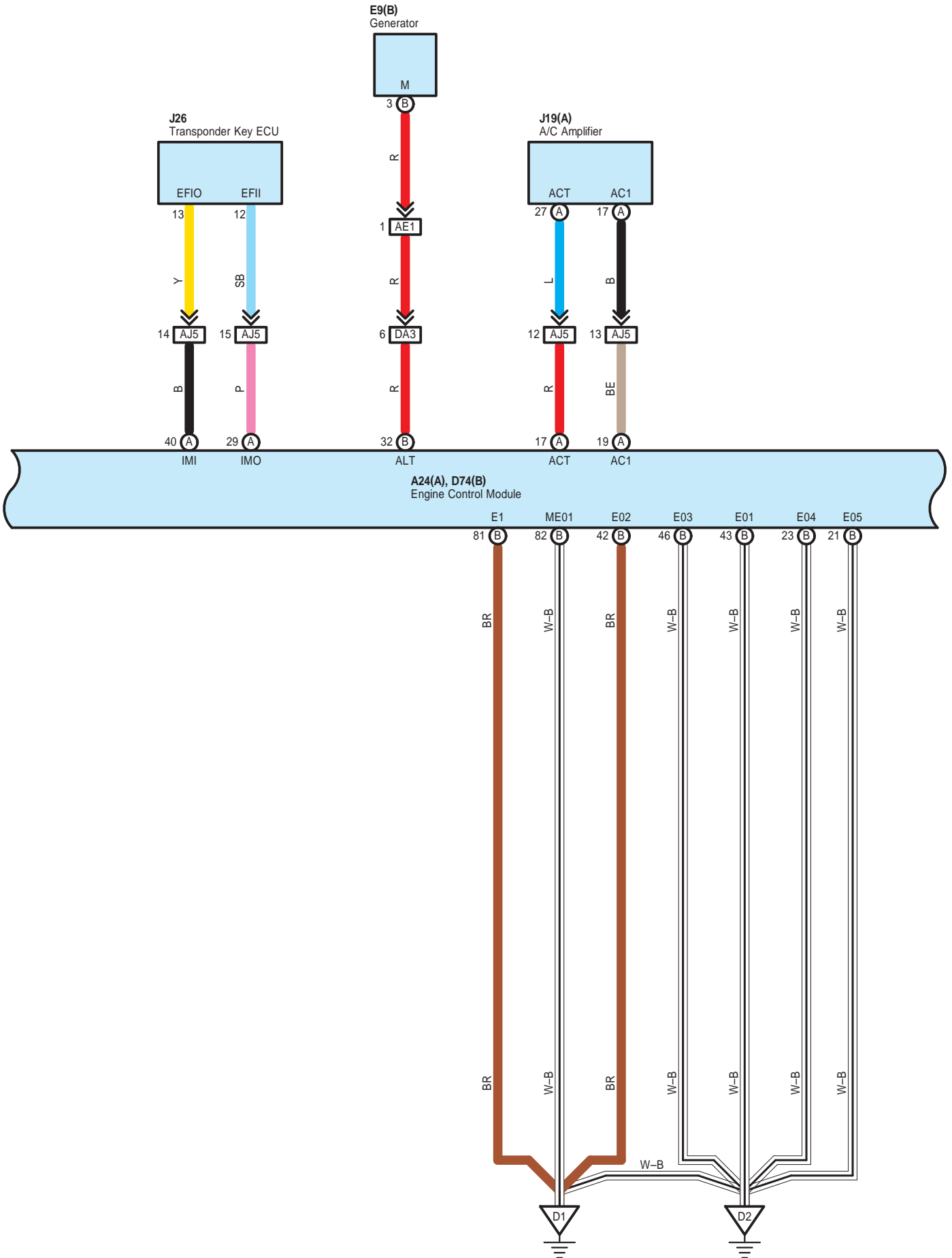

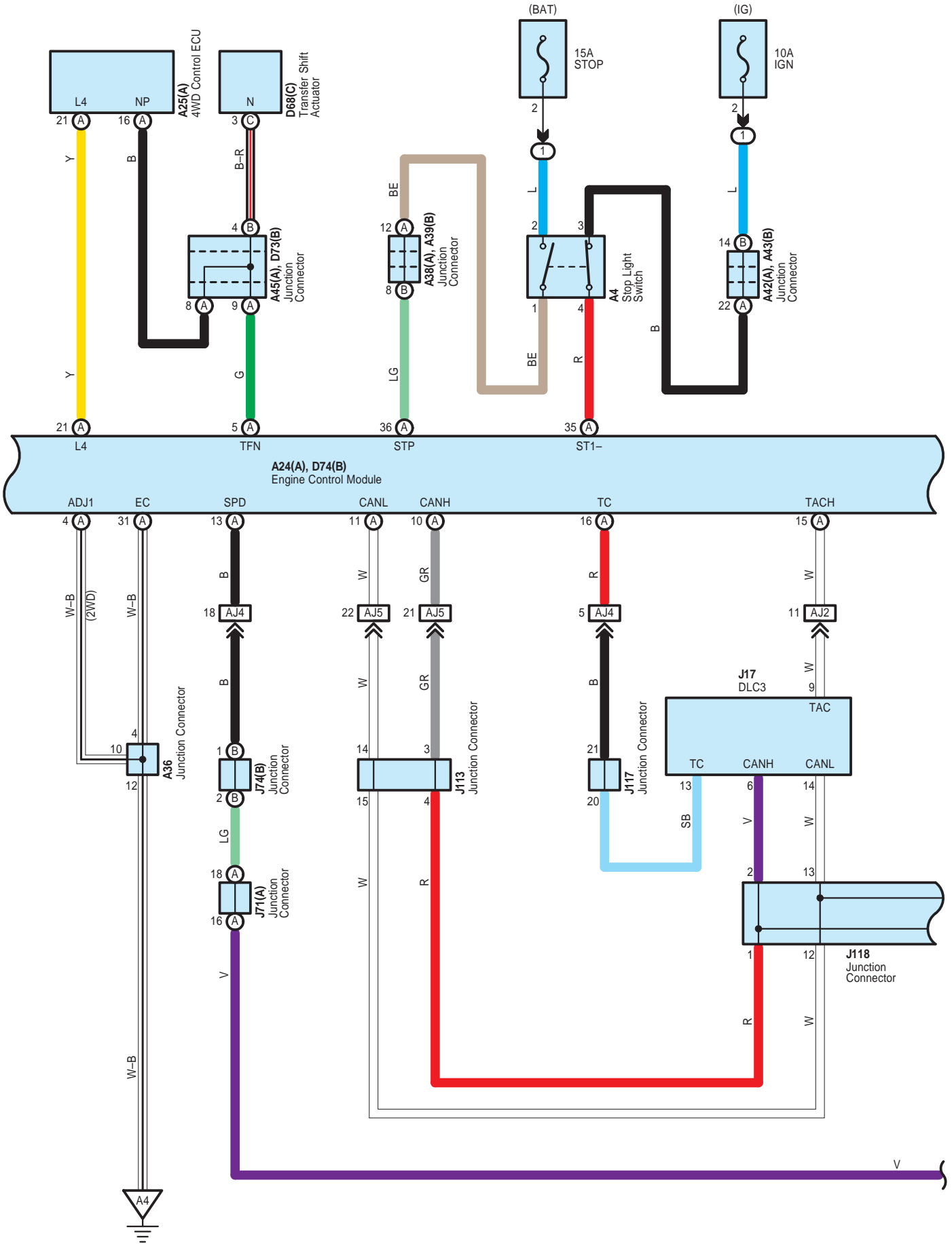

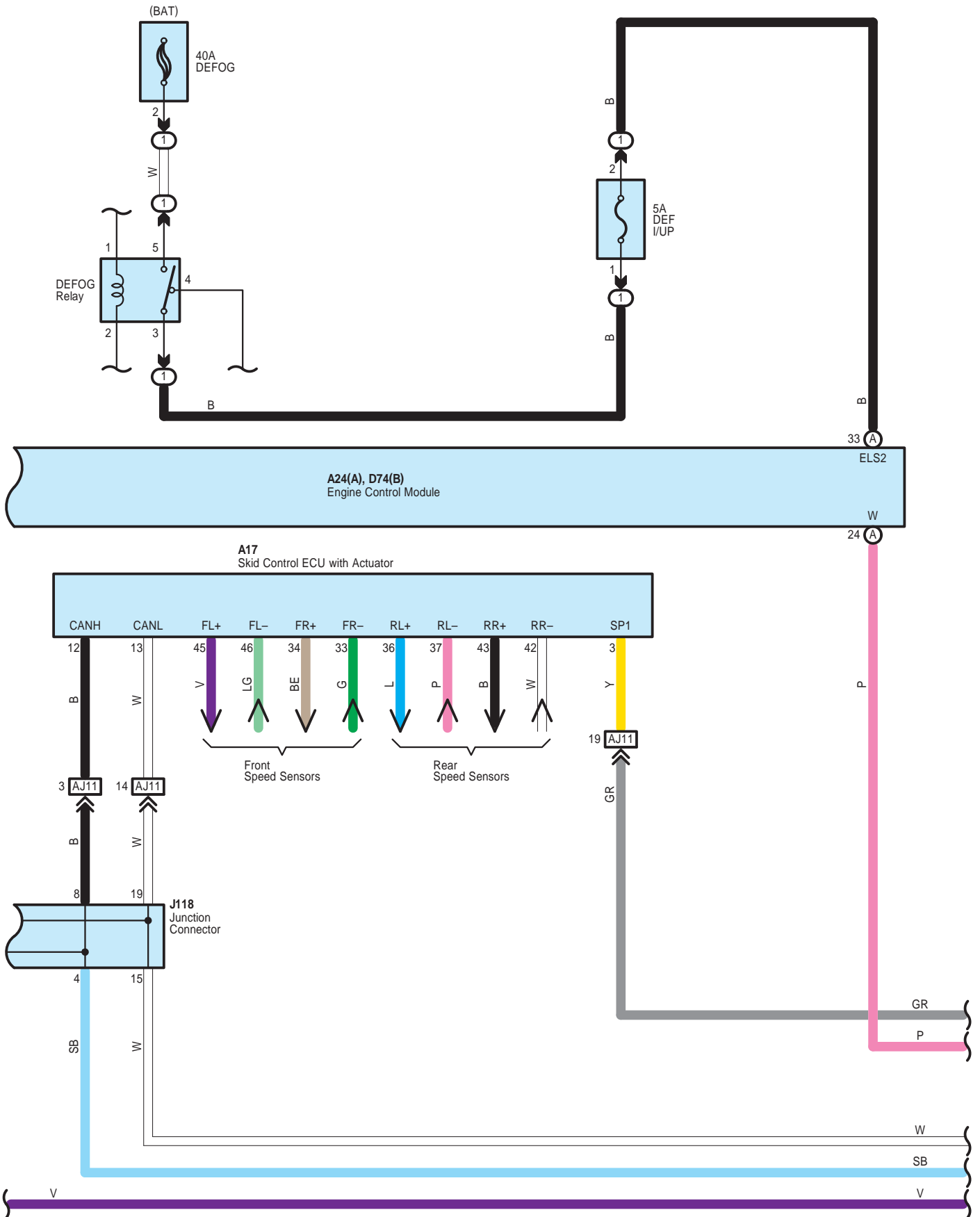

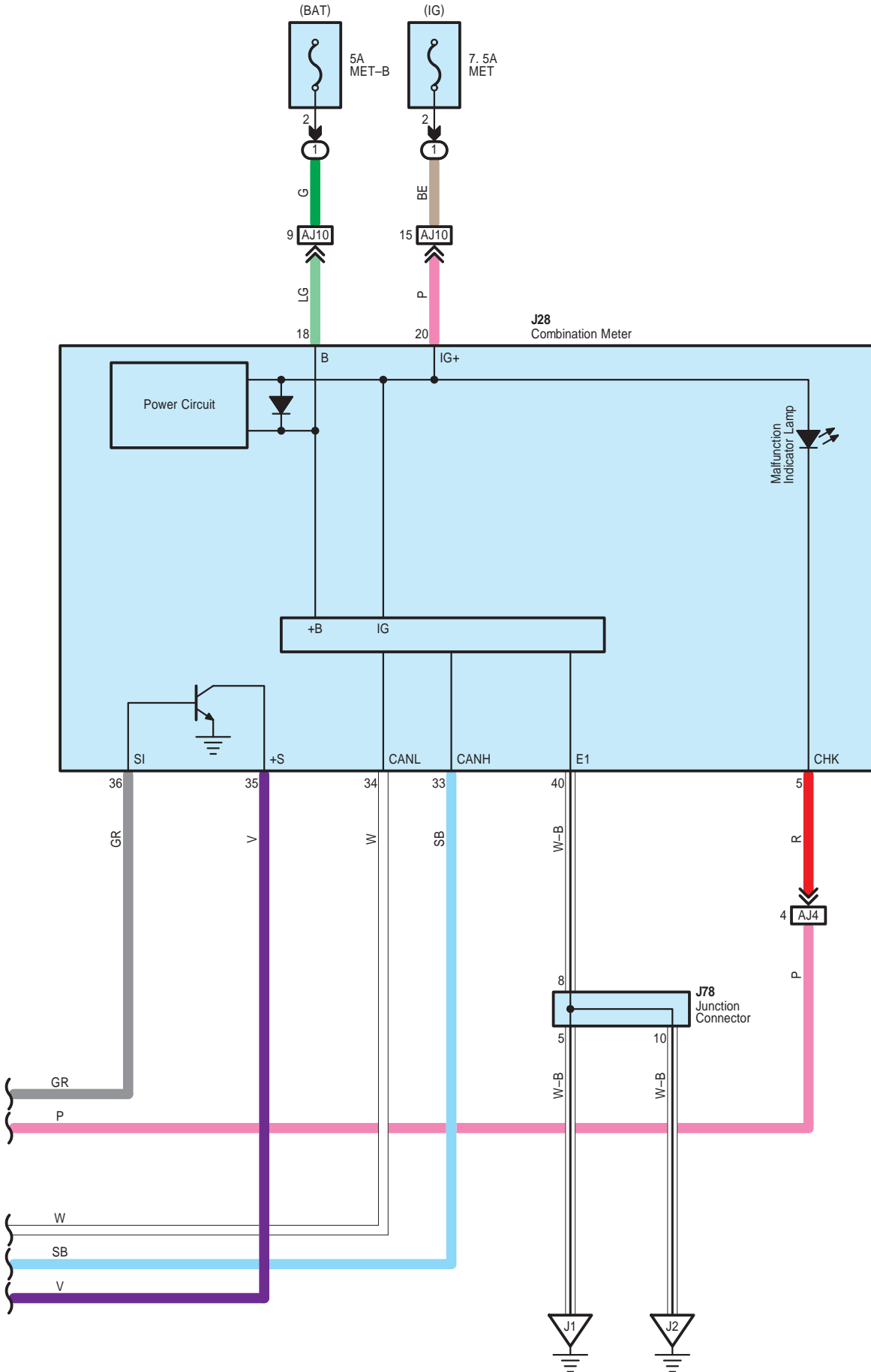

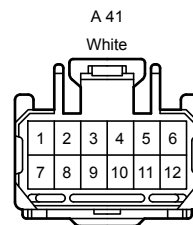
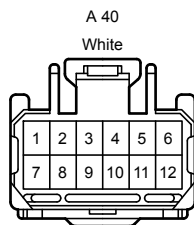
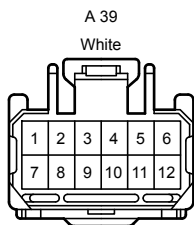
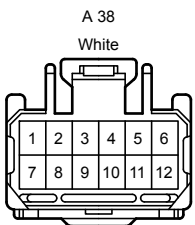
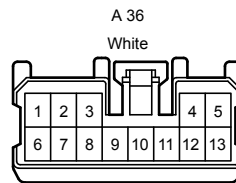
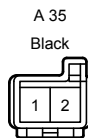
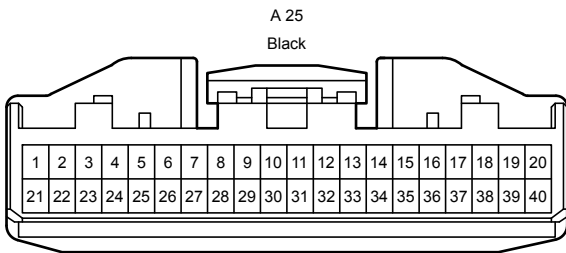
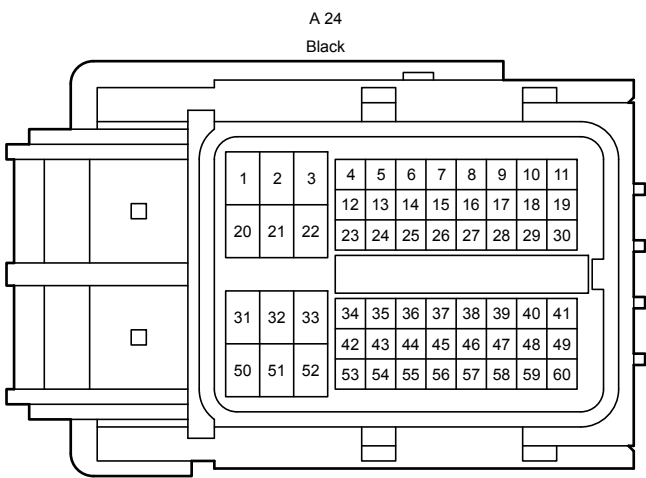
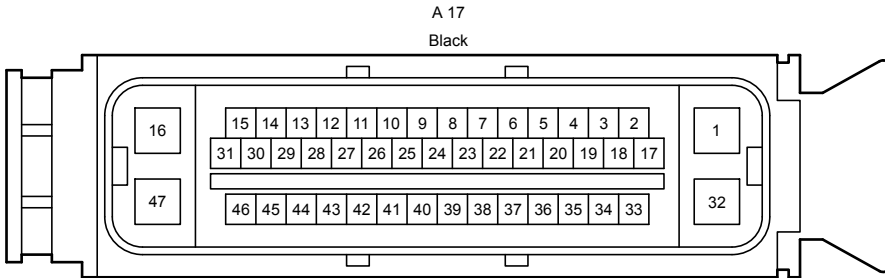
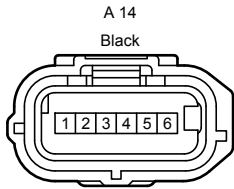
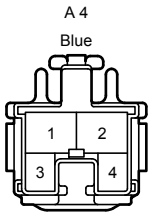

Engine Control <3UR-FE, 3UR-FBE>

A 42  
White

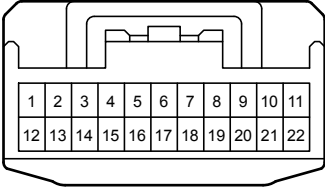

A 43  
White

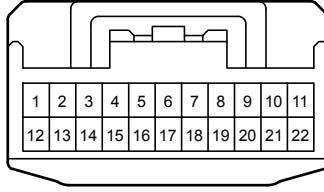

A 44  
White

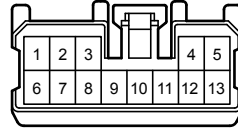

A 45  
Blue

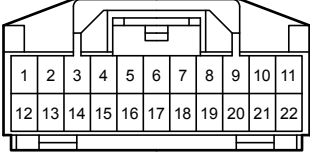

D 3  
Black

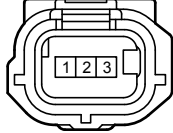

D 6  
Black

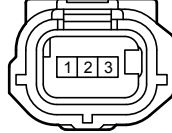

D 7  
Black

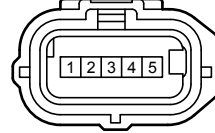

D 9  
Black

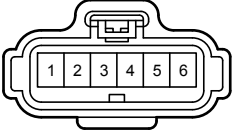

D 10  
Black

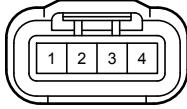

D 12  
Black

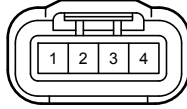

D 14  
Black

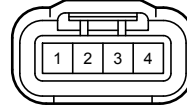

D 16  
Black

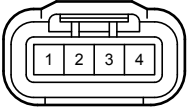

D 19  
Black

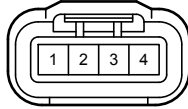

D 21  
Black

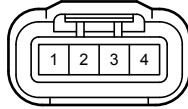

D 23  
Black

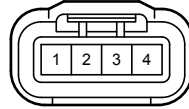

D 25  
Black

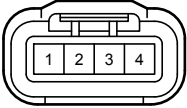

D 28  
Dark Gray



D 29  
Black

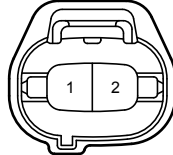

D 31  
Dark Gray



D 32  
Dark Gray



D 33  
Dark Gray



D 34  
Dark Gray



D 35  
Gray

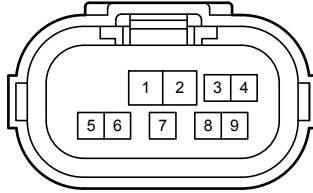

D 37  
Black

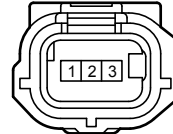

D 39  
Black

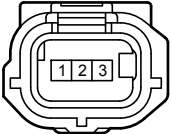

D 40  
Black

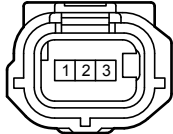

D 41  
Black

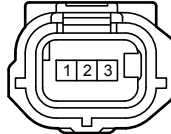

D 44  
Black



D 45  
Black





F 4

Black

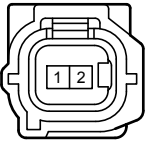

H 1

Black

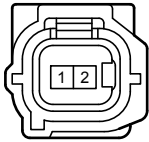

H 2

Black

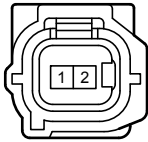

H 3

Black

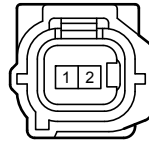

H 4

Black

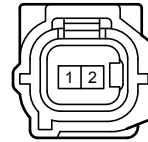

J 9

White

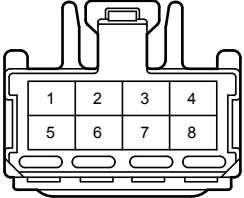

J 17

White

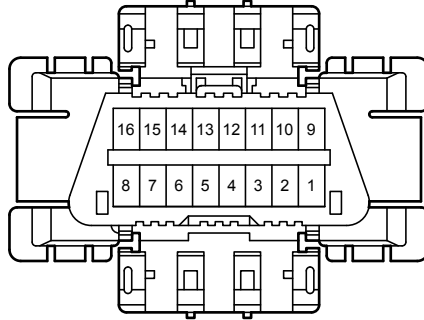

J 19

White

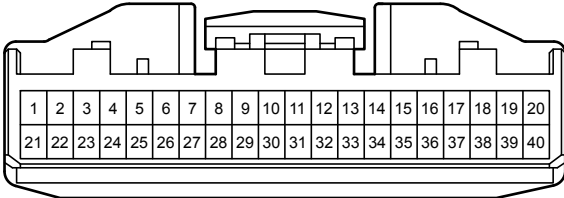

J 26

White

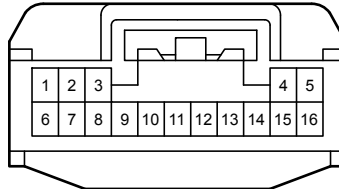

J 28

White

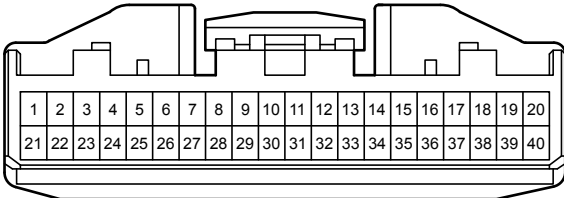

J 71

Black

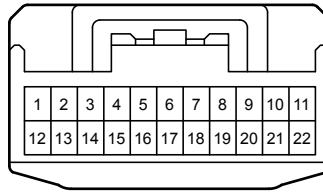

J 74

Black

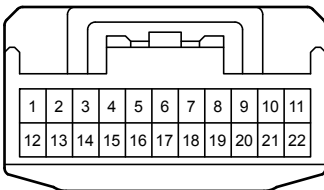

J 78

White

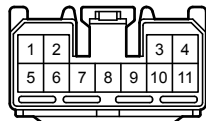

J113

Gray

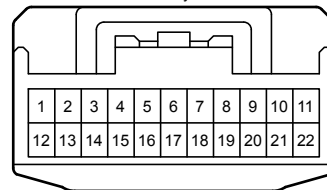

J117

Black

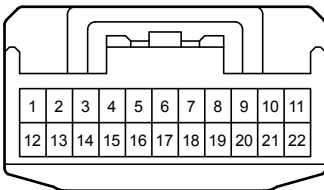

J118

Gray

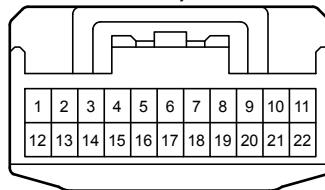

R 1

Black

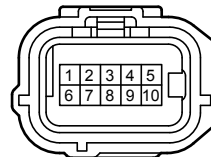



Engine Control <3UR-FE, 3UR-FBE>

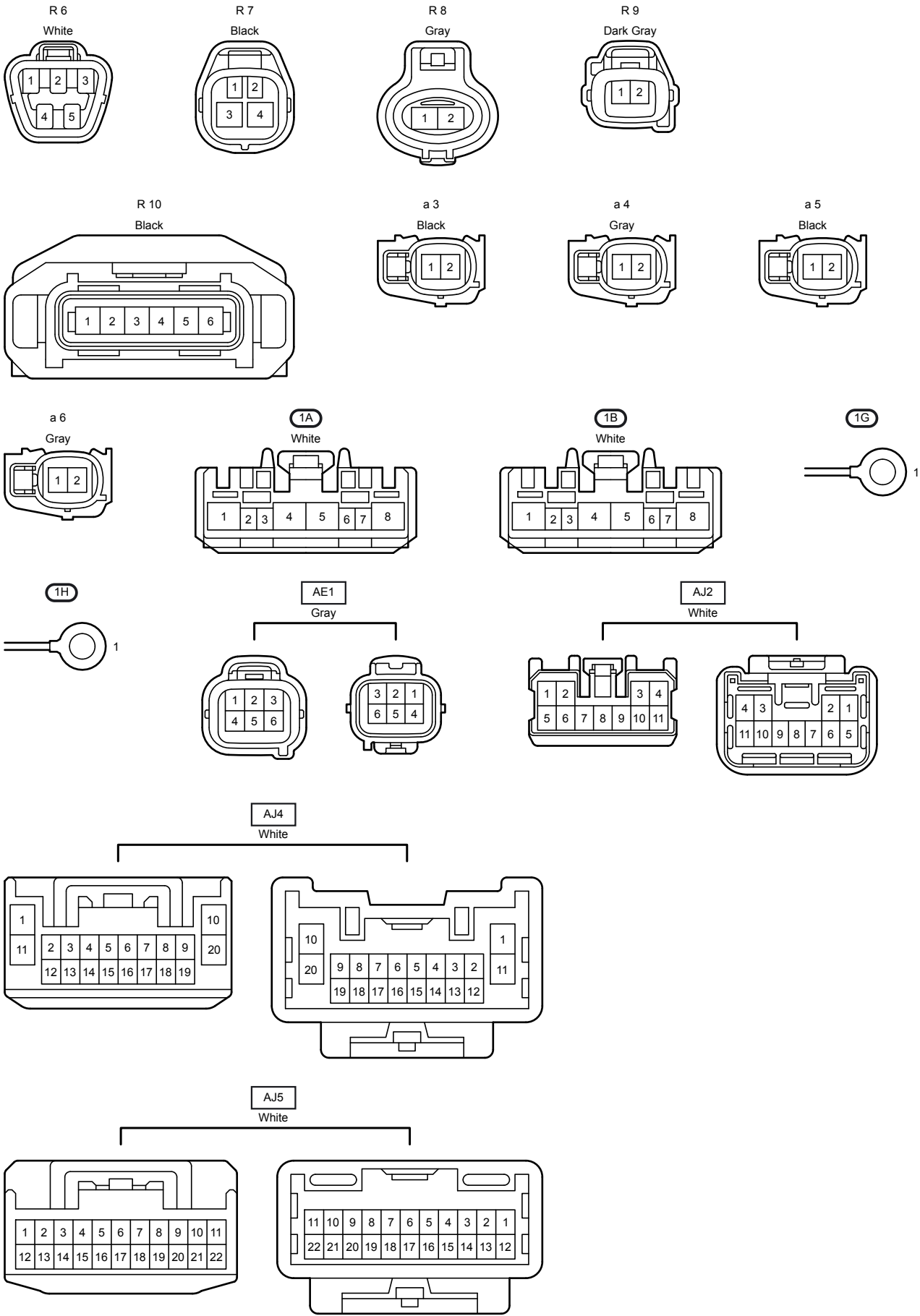

AJ9  
Gray

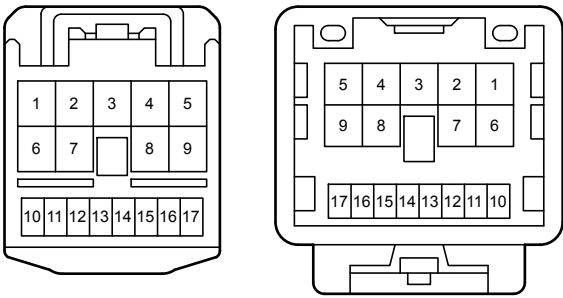

AJ10  
Gray

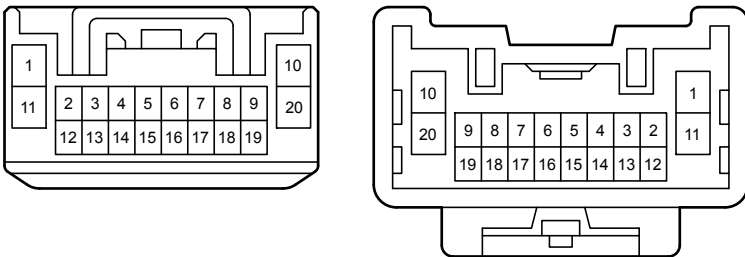

AJ11  
Gray

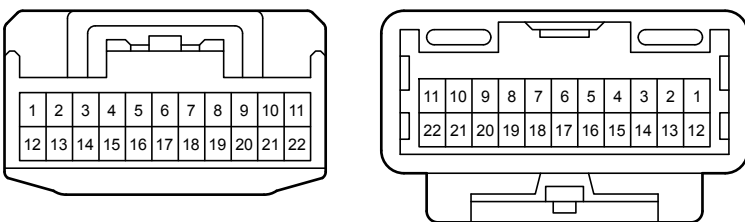

DA1  
White

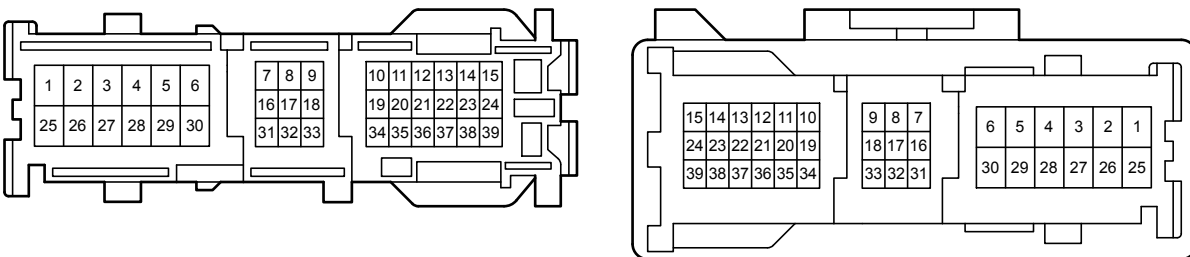



# Engine Immobiliser System

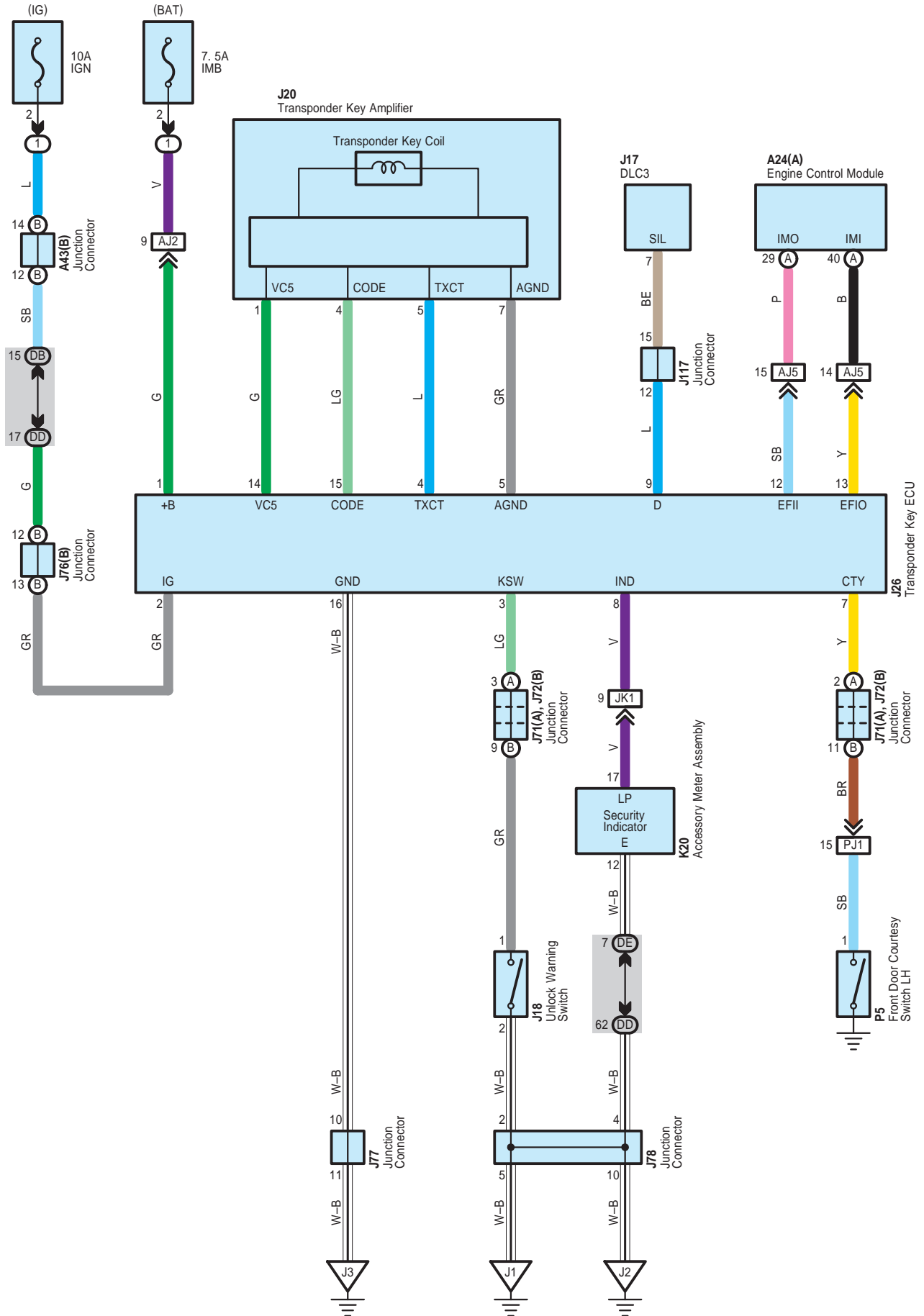

# Engine Immobiliser System

A 24  
Black

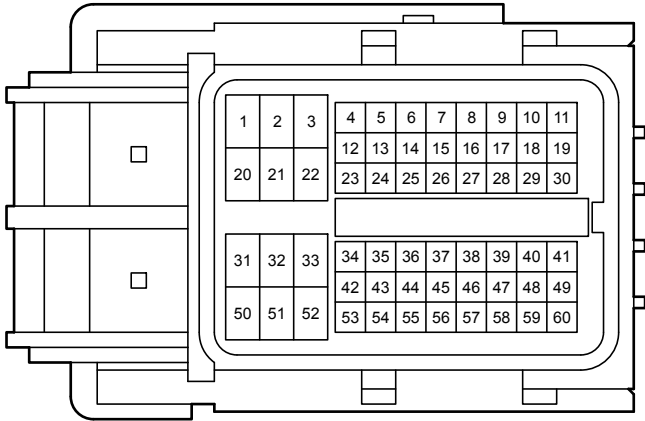

A 43  
White

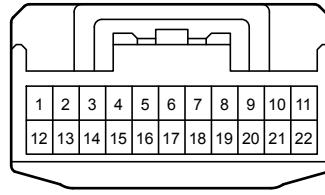

J 17  
White

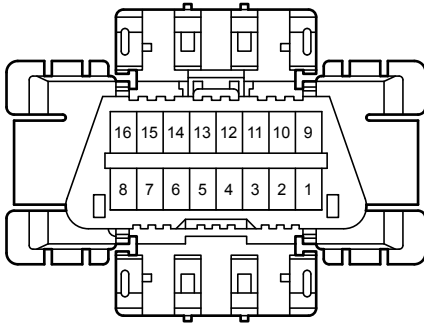

J 18  
White



J 20  
Black

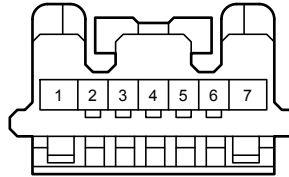

J 26  
White

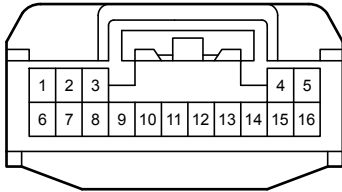

J 71  
Black

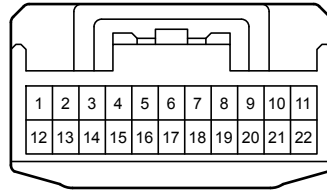

J 72  
Black

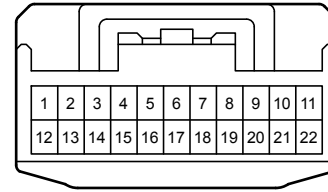

J 76  
White

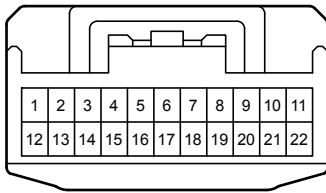

J 77  
Gray

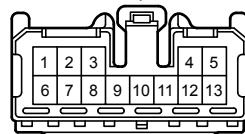

J 78  
White

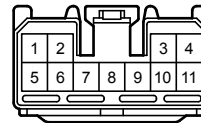

J117  
Black

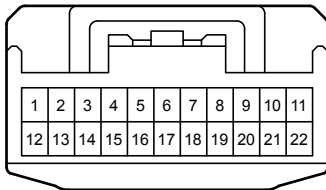

K 20  
White

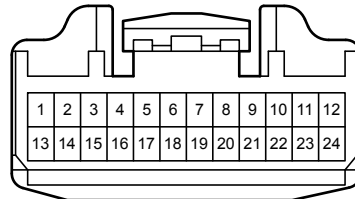

P 5  
White



# Engine Immobiliser System

**DB**  
White

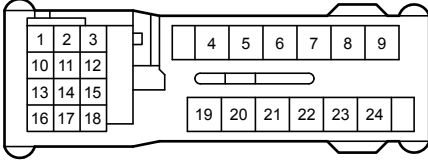

**DD**  
White

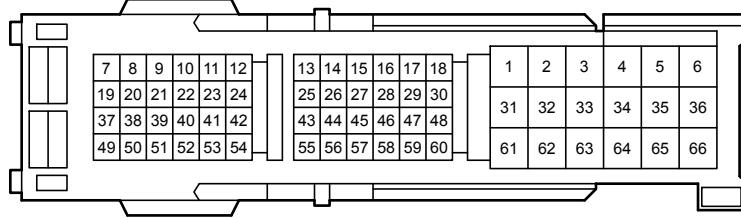

**DE**  
White

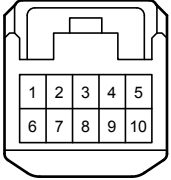

**AJ2**  
White

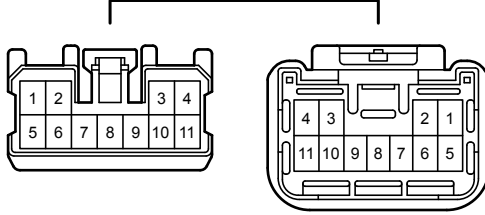

**AJ5**  
White

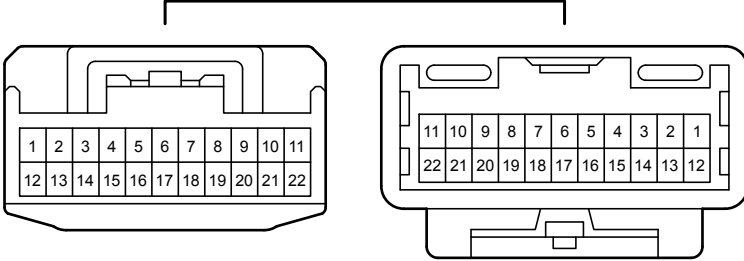

**JK1**  
White

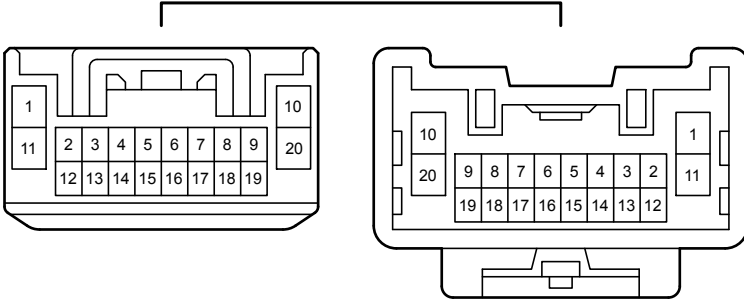

**PJ1**  
Black

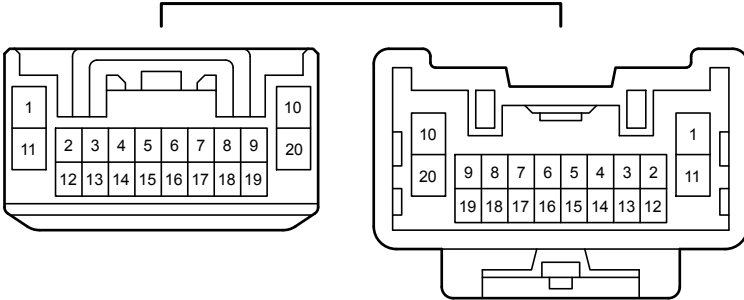

# Front Fog Light

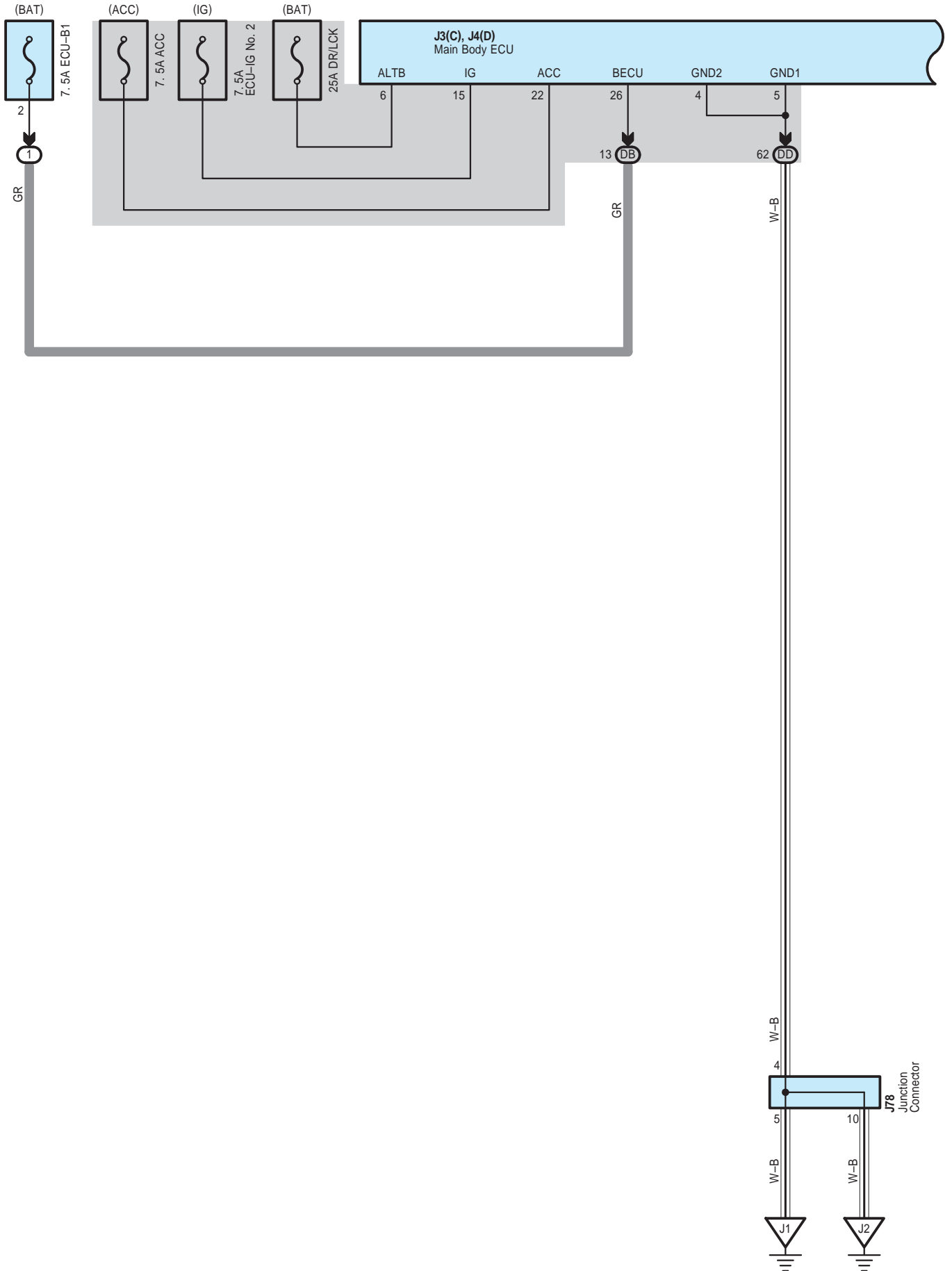

# Front Fog Light

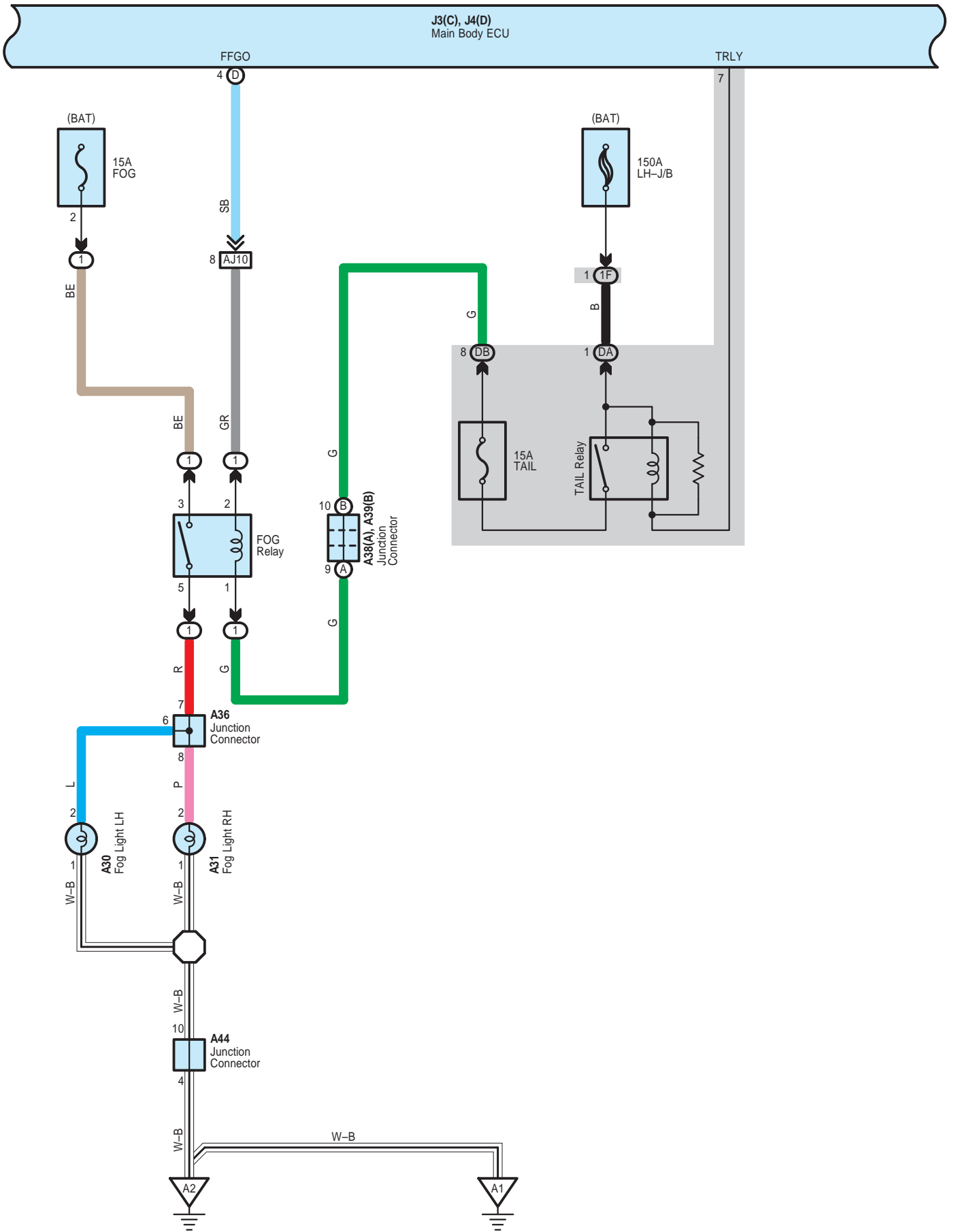



# Front Fog Light

\* 1 : w/ Seat Position Memory

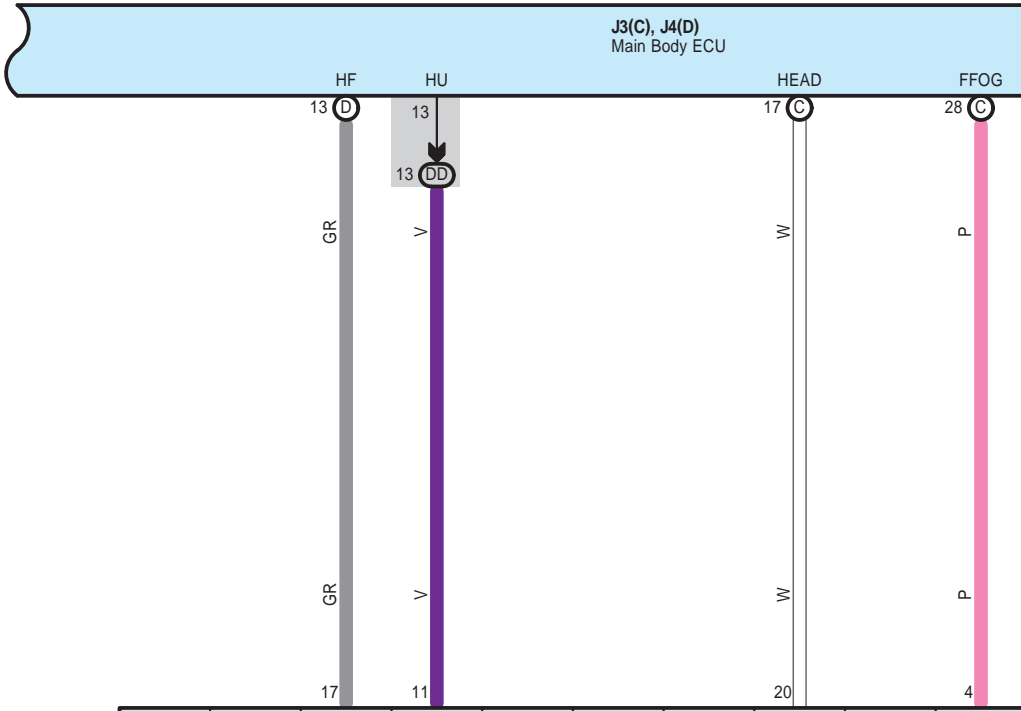

		HF	HU	HL	EL	T	H	A	BFG	LFG
Light Control Switch	OFF									
	Tail				○—○					
	Head				○—○	○—○				
	AUTO				○—○		○—○			
Dimmer Switch	Flash	○—○	○—○	○—○						
	Low			○—○	○—○					
	High		○—○	○—○	○—○					
Fog Light Switch	OFF								○—○	
	On								○—○	

J10 Headlight Dimmer Switch Assembly

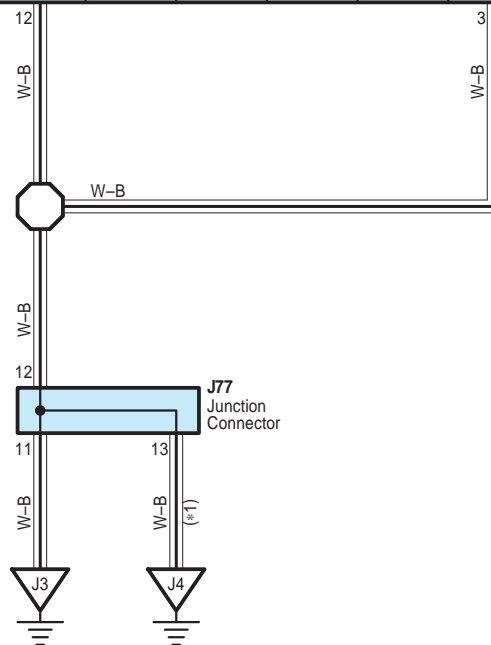

# Front Fog Light

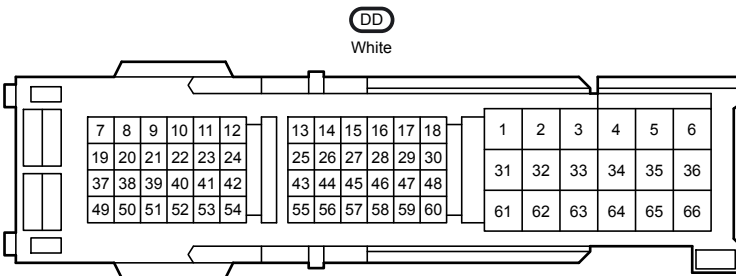
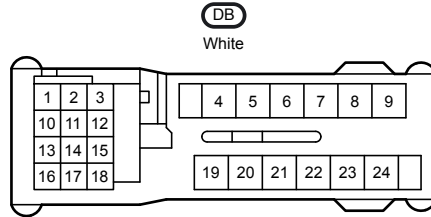
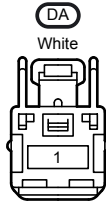
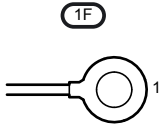
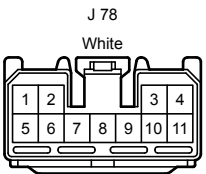
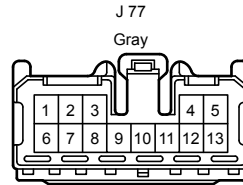
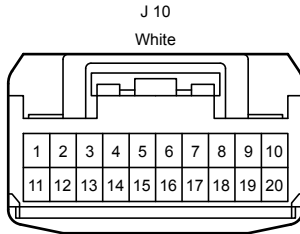
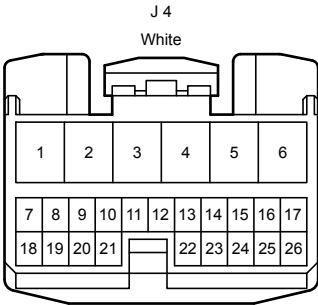
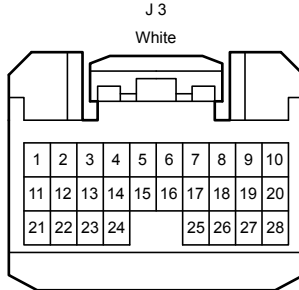
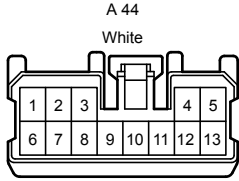
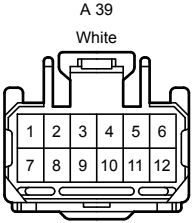
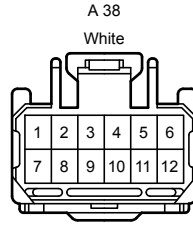
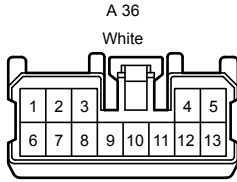
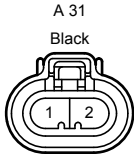
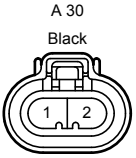

Front Fog Light

AJ10  
Gray

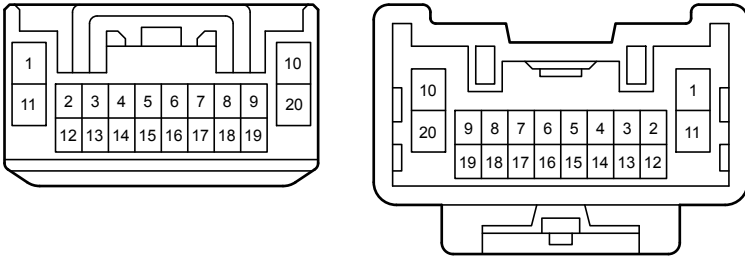

# Front Window Deicer

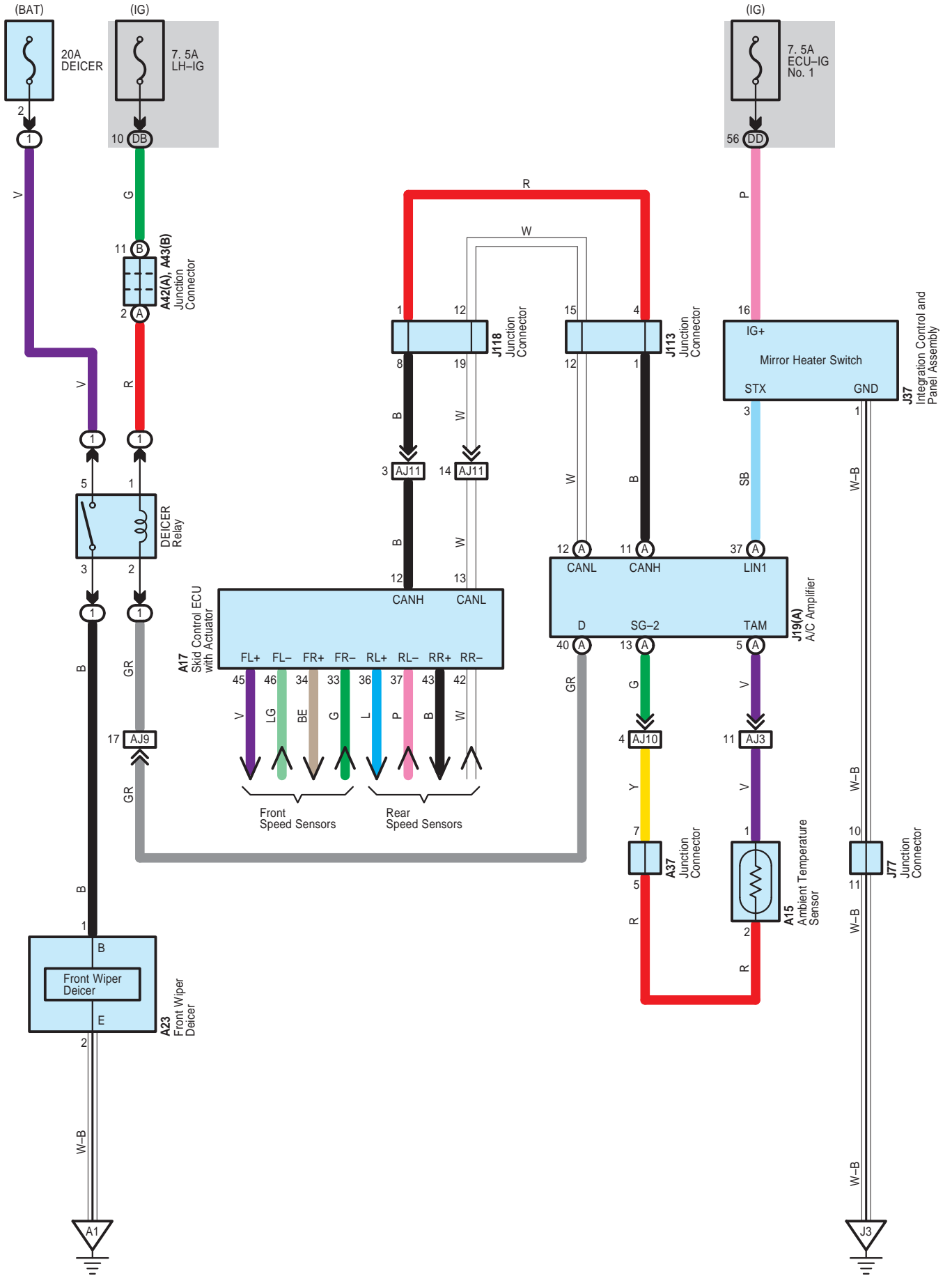



AJ3  
White

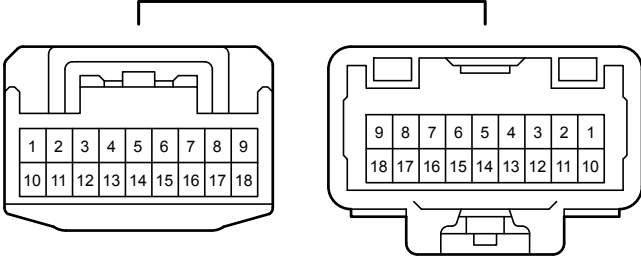

AJ9  
Gray

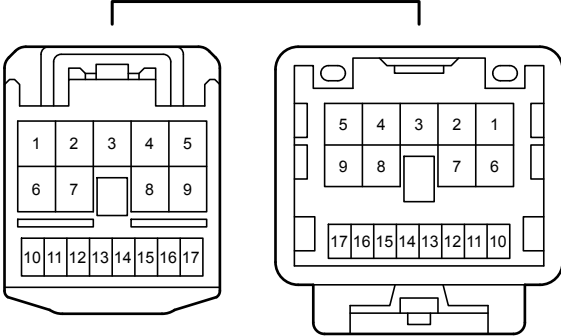

AJ10  
Gray

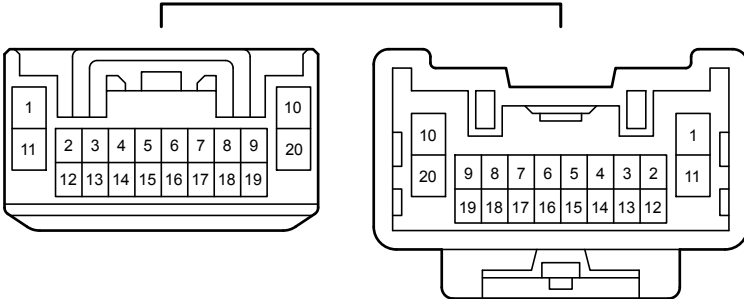

AJ11  
Gray

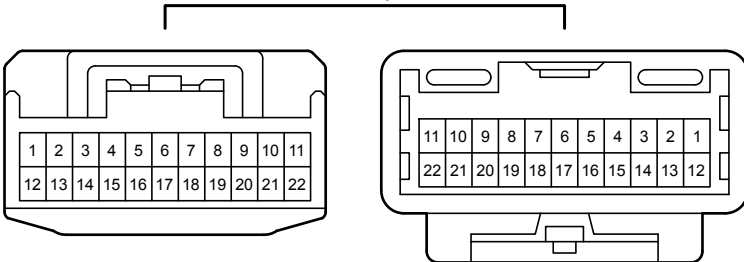

Front Wiper and Washer <w/o Intermittent Wiper>

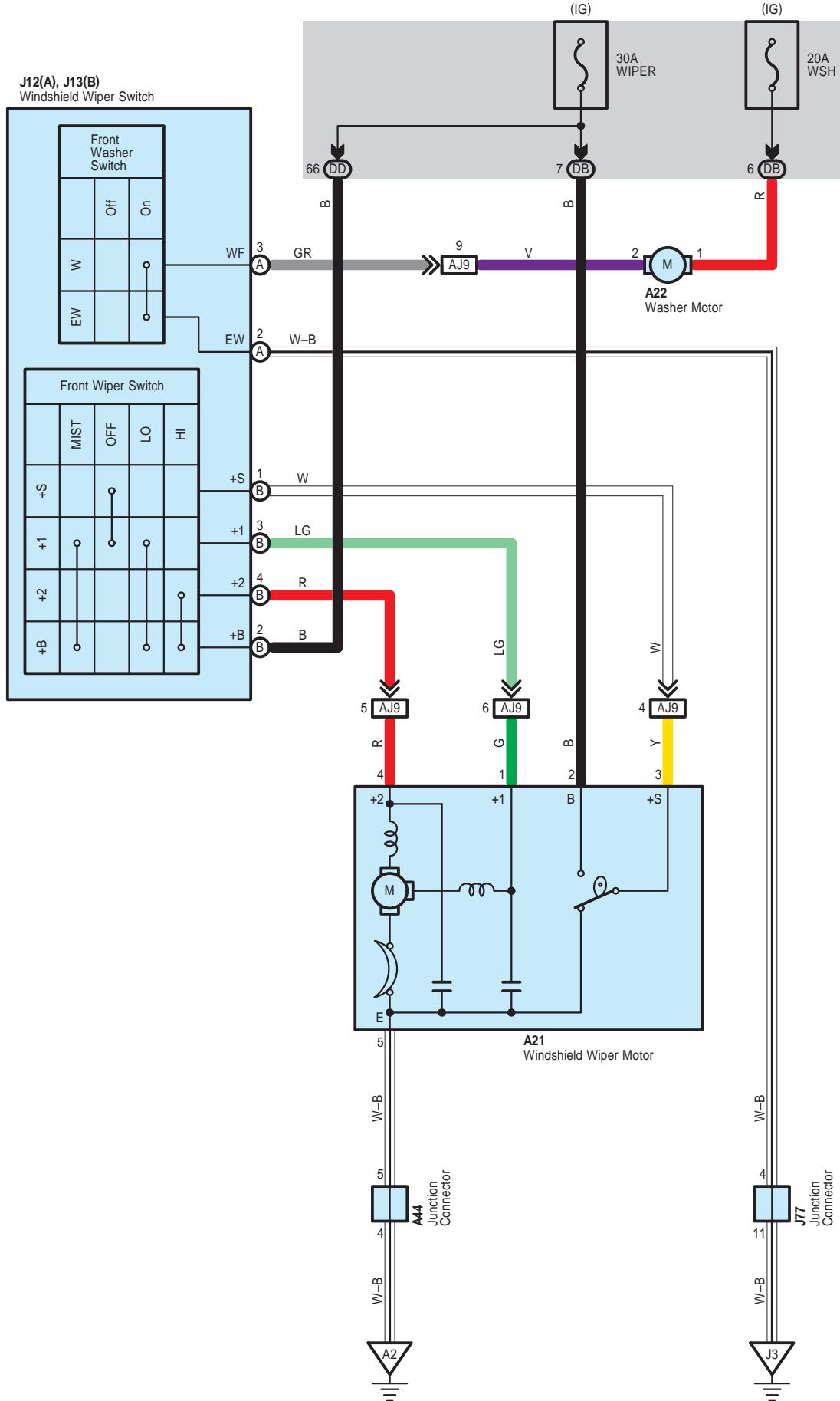

Front Wiper and Washer <w/o Intermittent Wiper>

A 21

Black

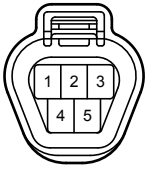

A 22

Black

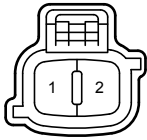

A 44

White

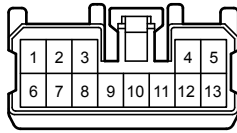

J 12

White

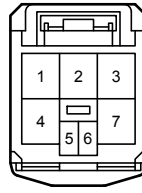

J 13

White

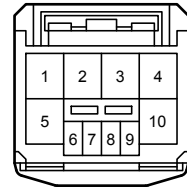

J 77

Gray

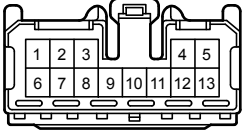

DB

White

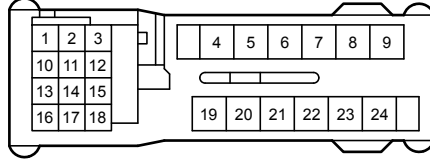

DD

White

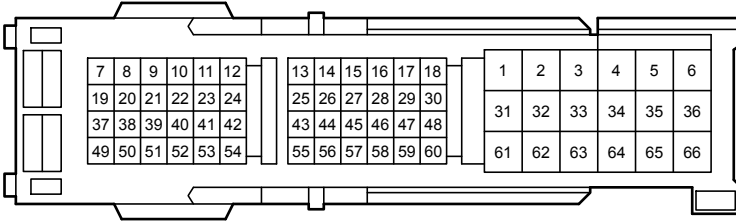

AJ9

Gray

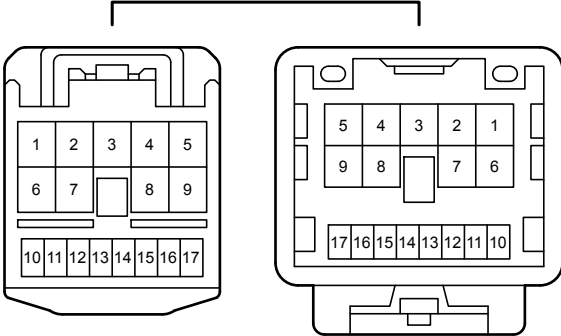



Front Wiper and Washer <w/ Intermittent Wiper>

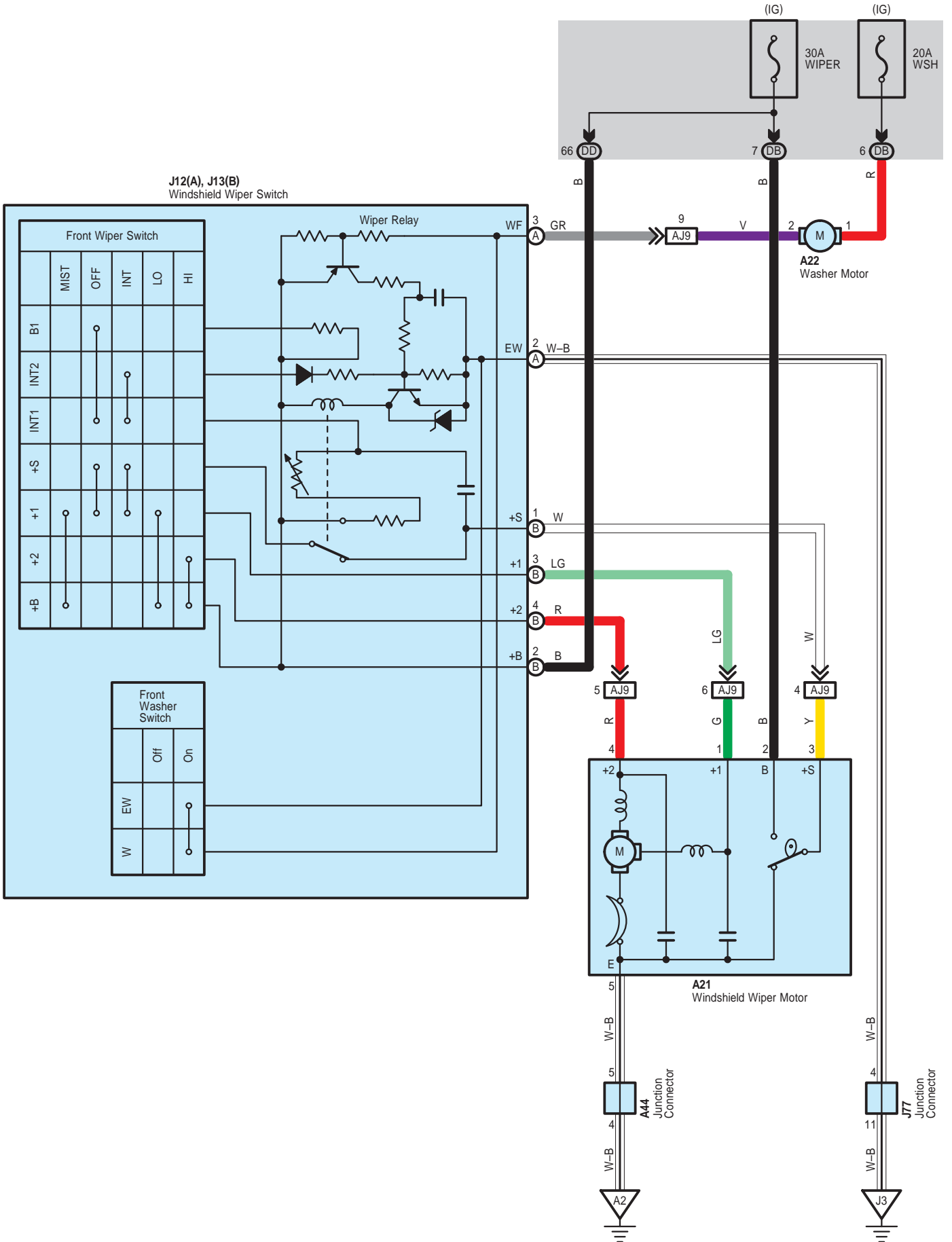

Front Wiper and Washer <w/ Intermittent Wiper>

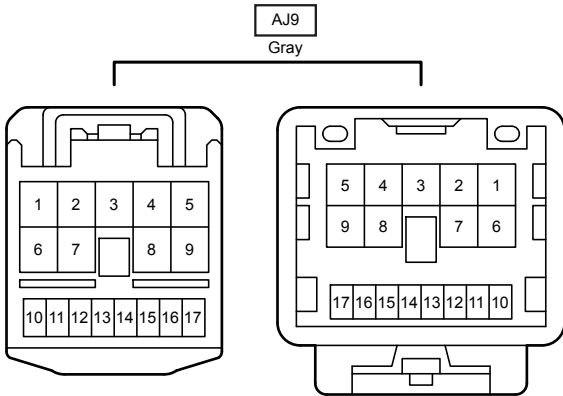
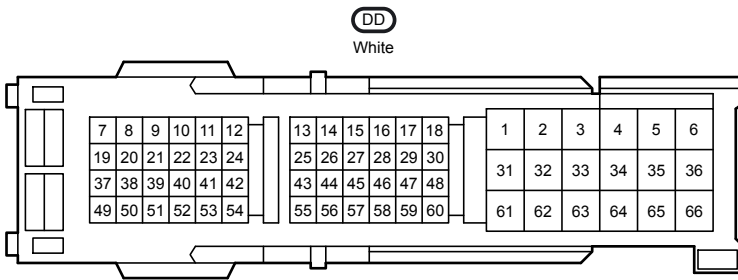
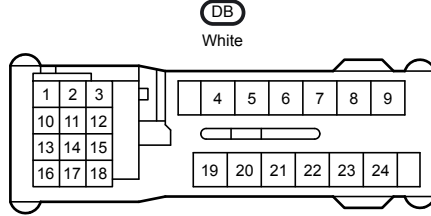
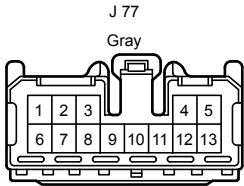
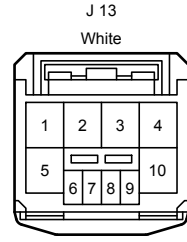
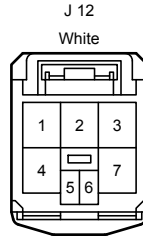
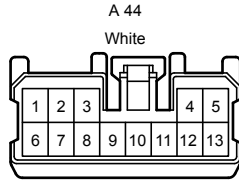
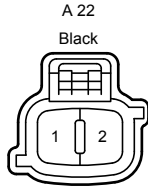
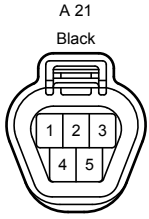

# Garage Door Opener

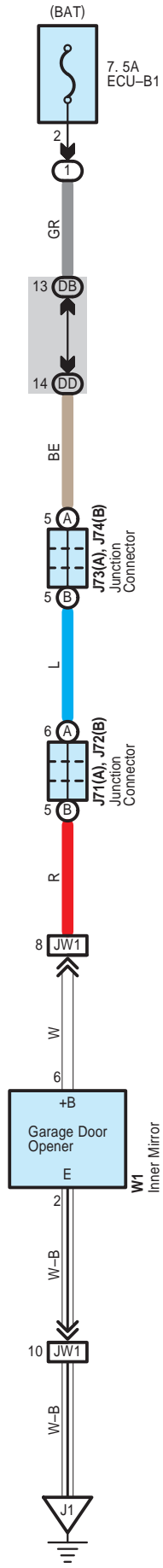

Garage Door Opener

J 71  
Black

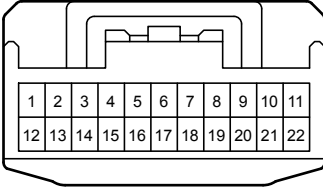

J 72  
Black

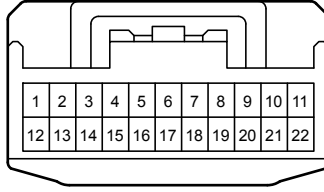

J 73  
Black

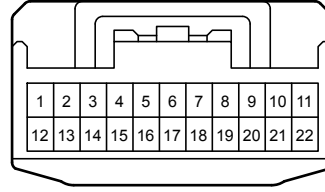

J 74  
Black

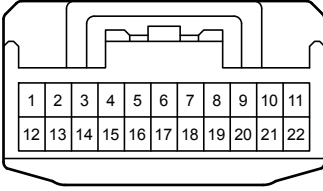

W 1  
Black

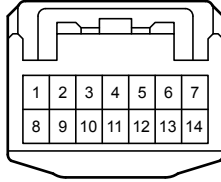

DB  
White

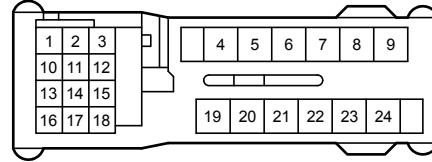

DD  
White

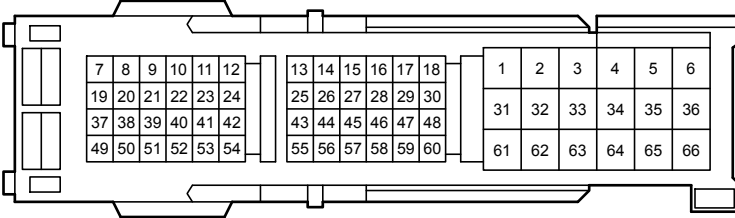

JW1  
White

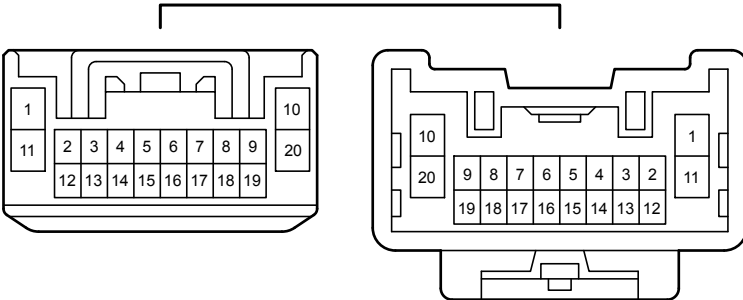

Ground Point

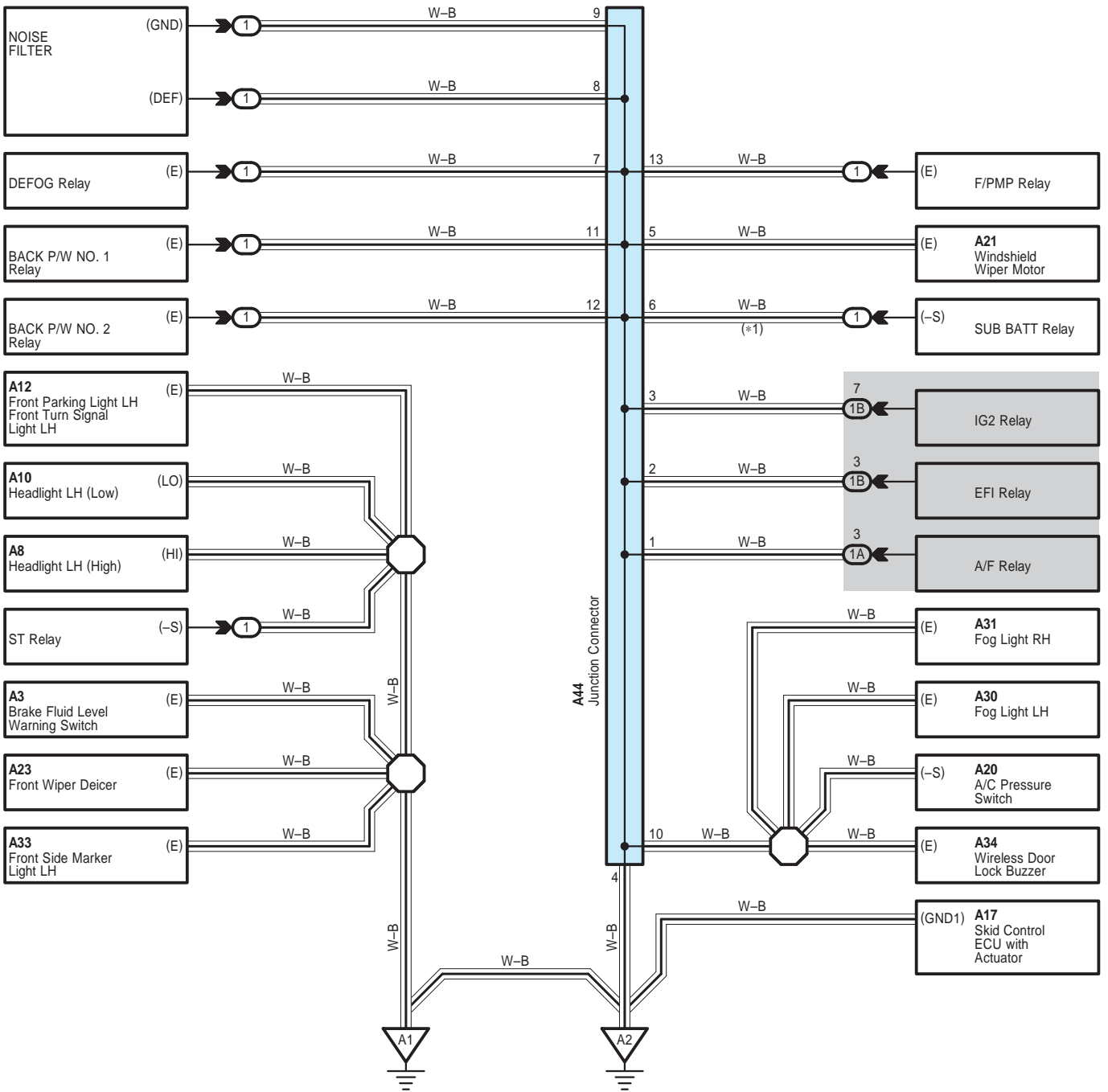

- \* 1 : Towing Package
- \* 2 : Except Towing Package
- \* 8 : Except 3UR-FBE
- \* 9 : 3UR-FBE

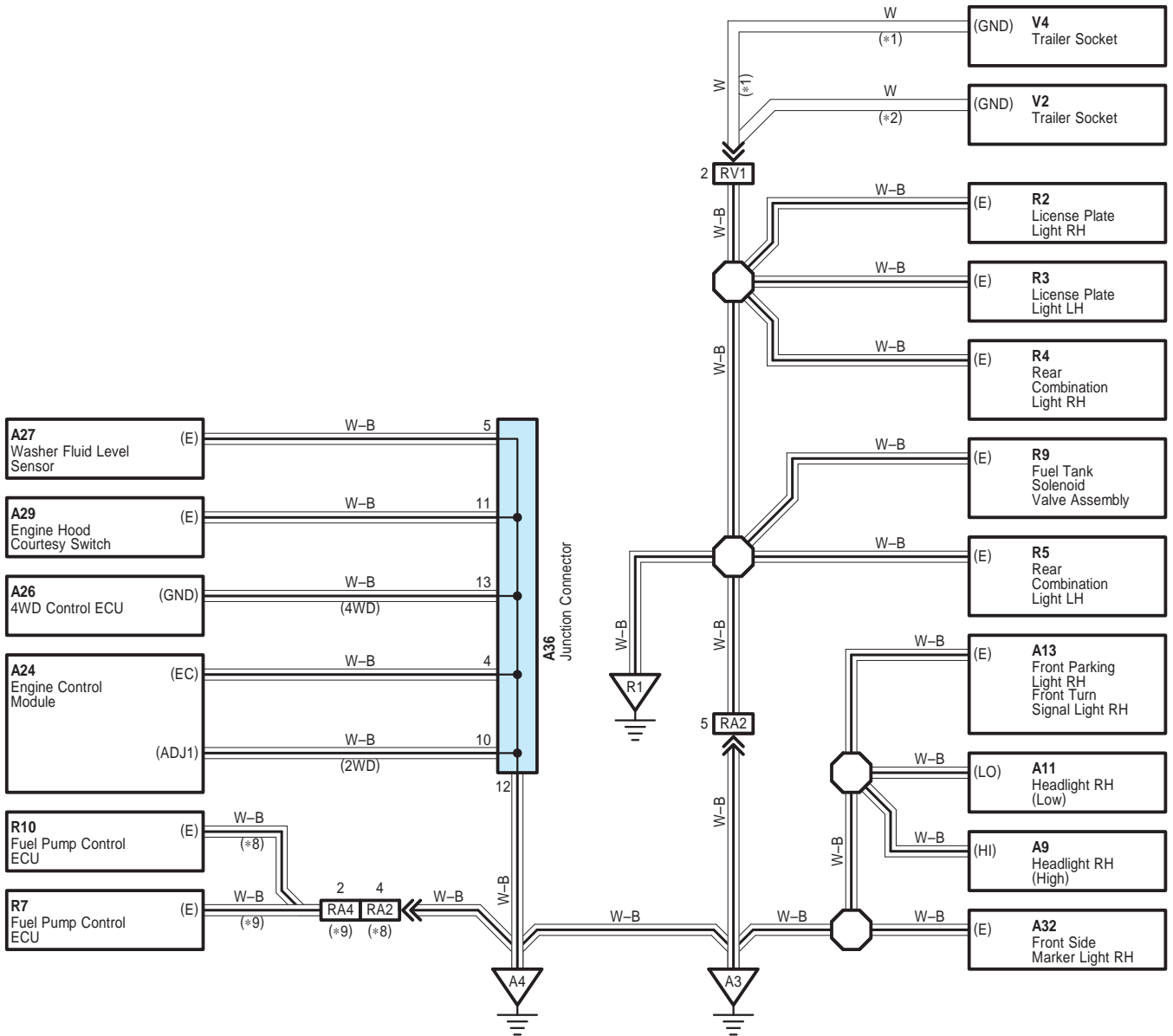

Ground Point

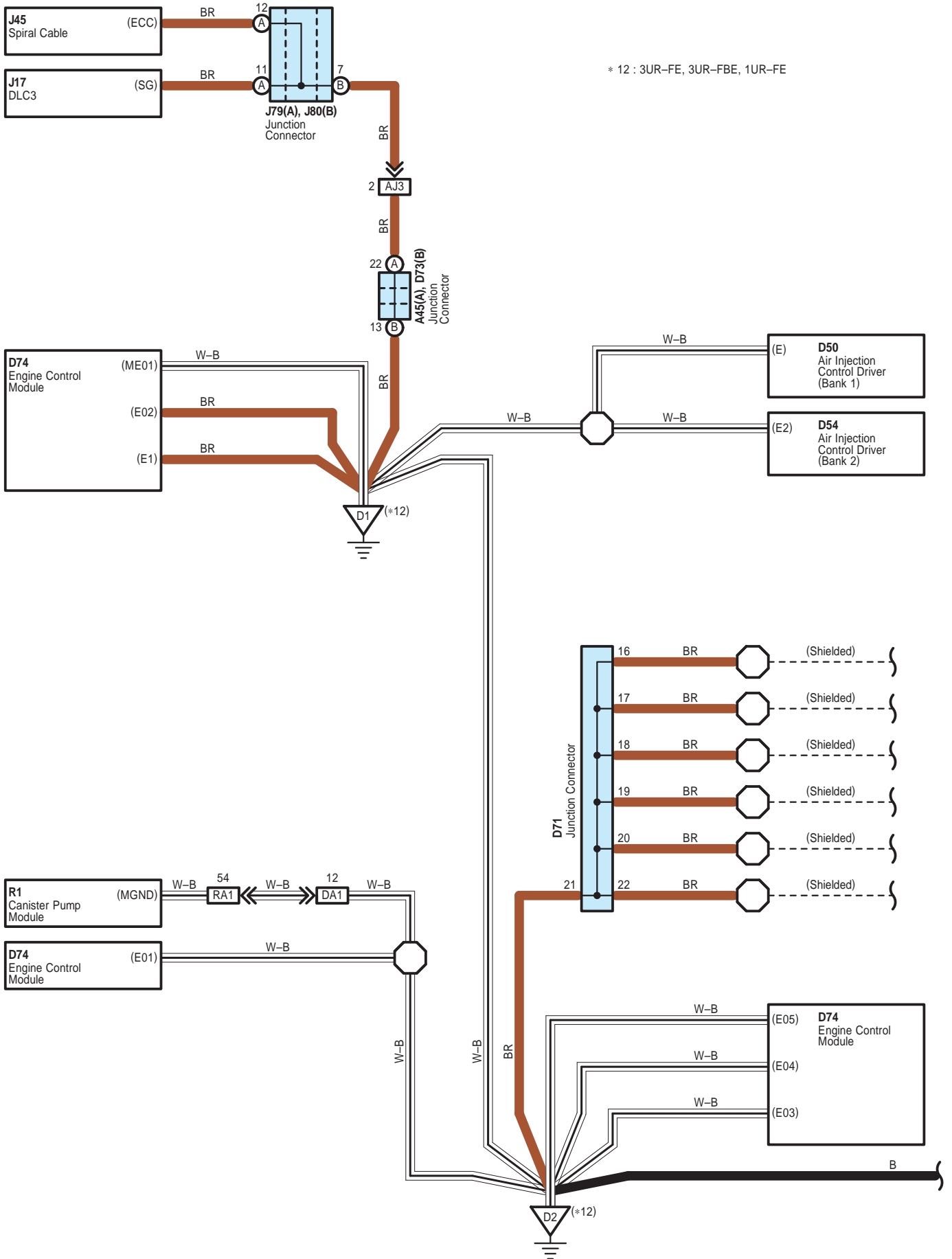

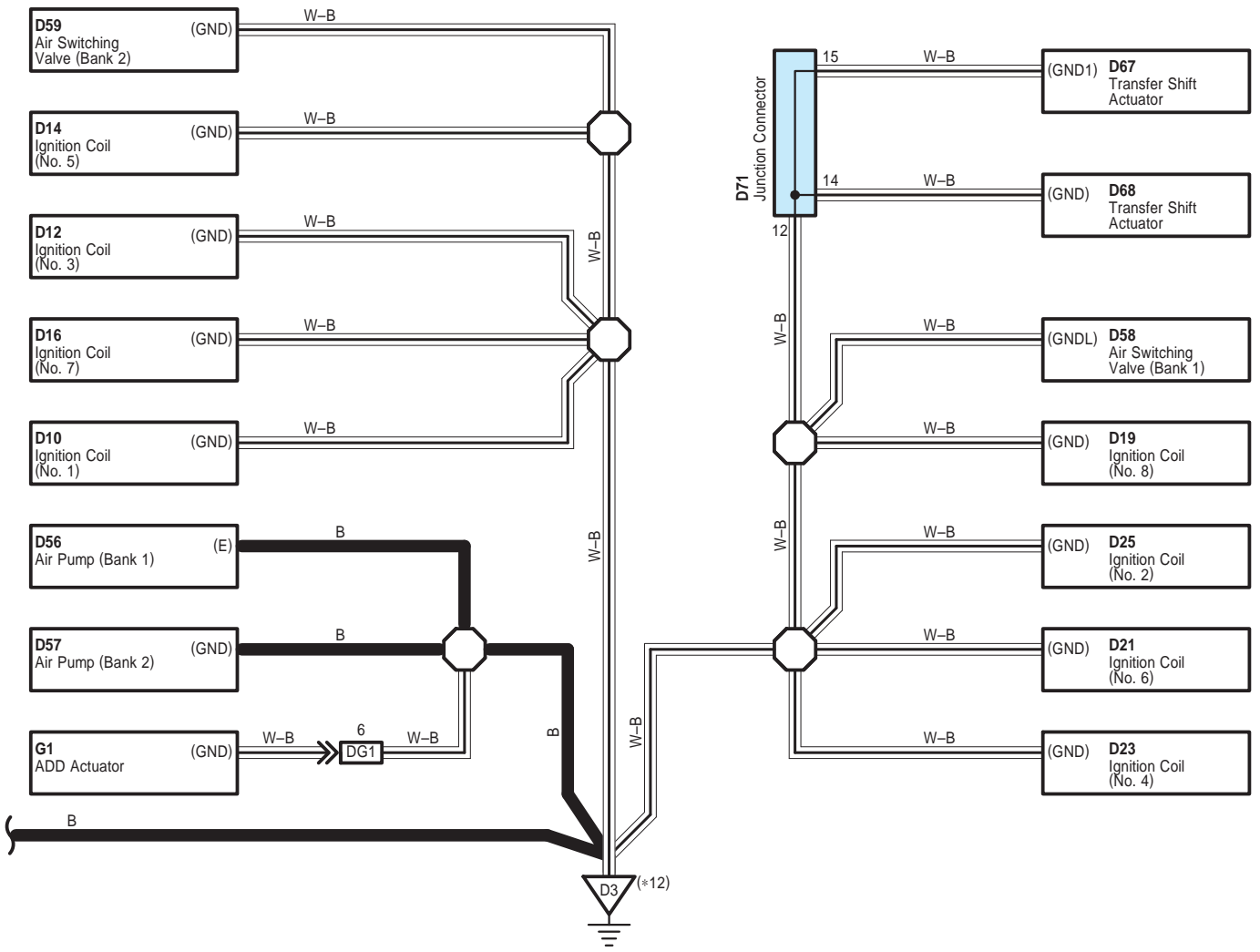



Ground Point

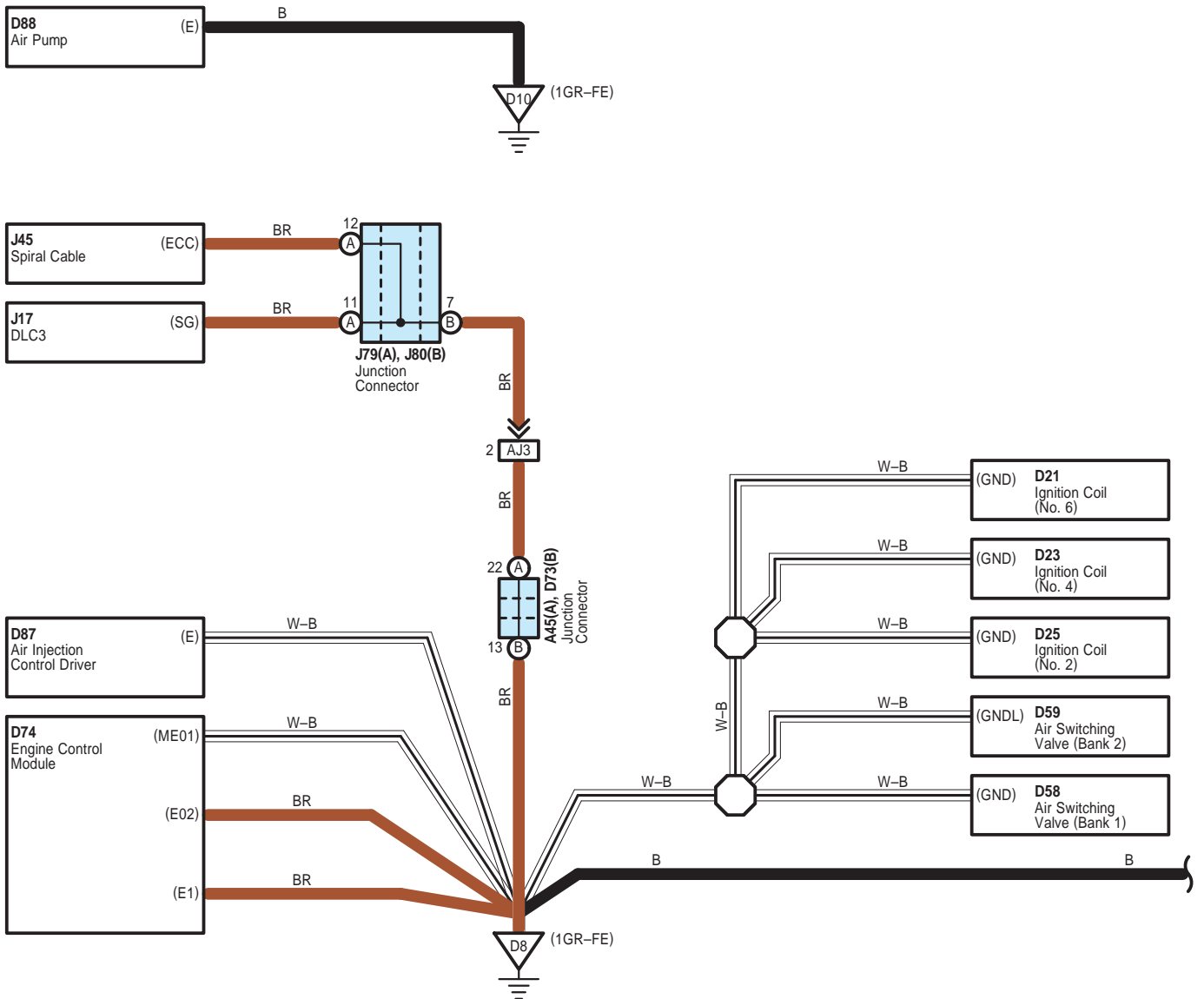

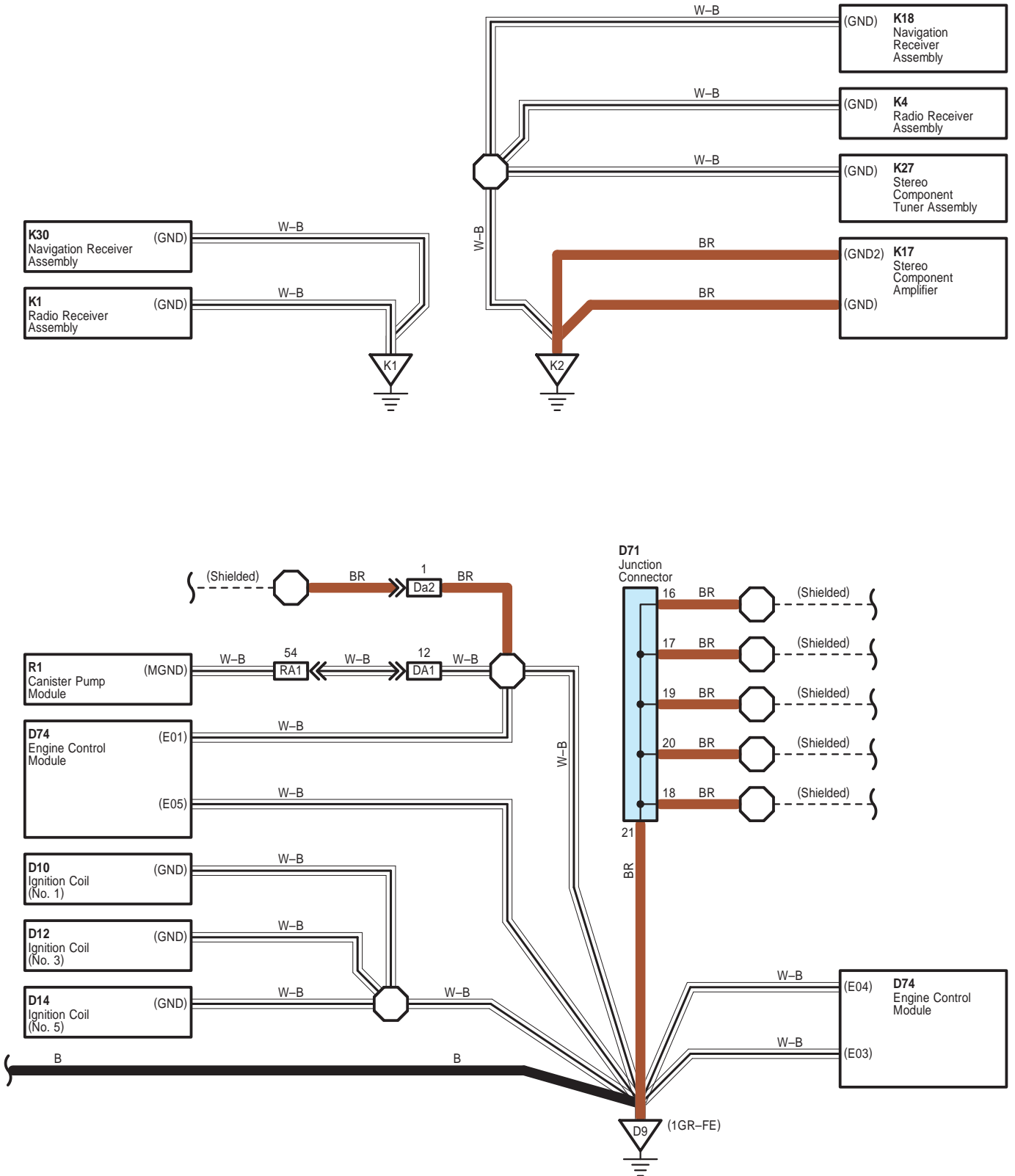

Ground Point

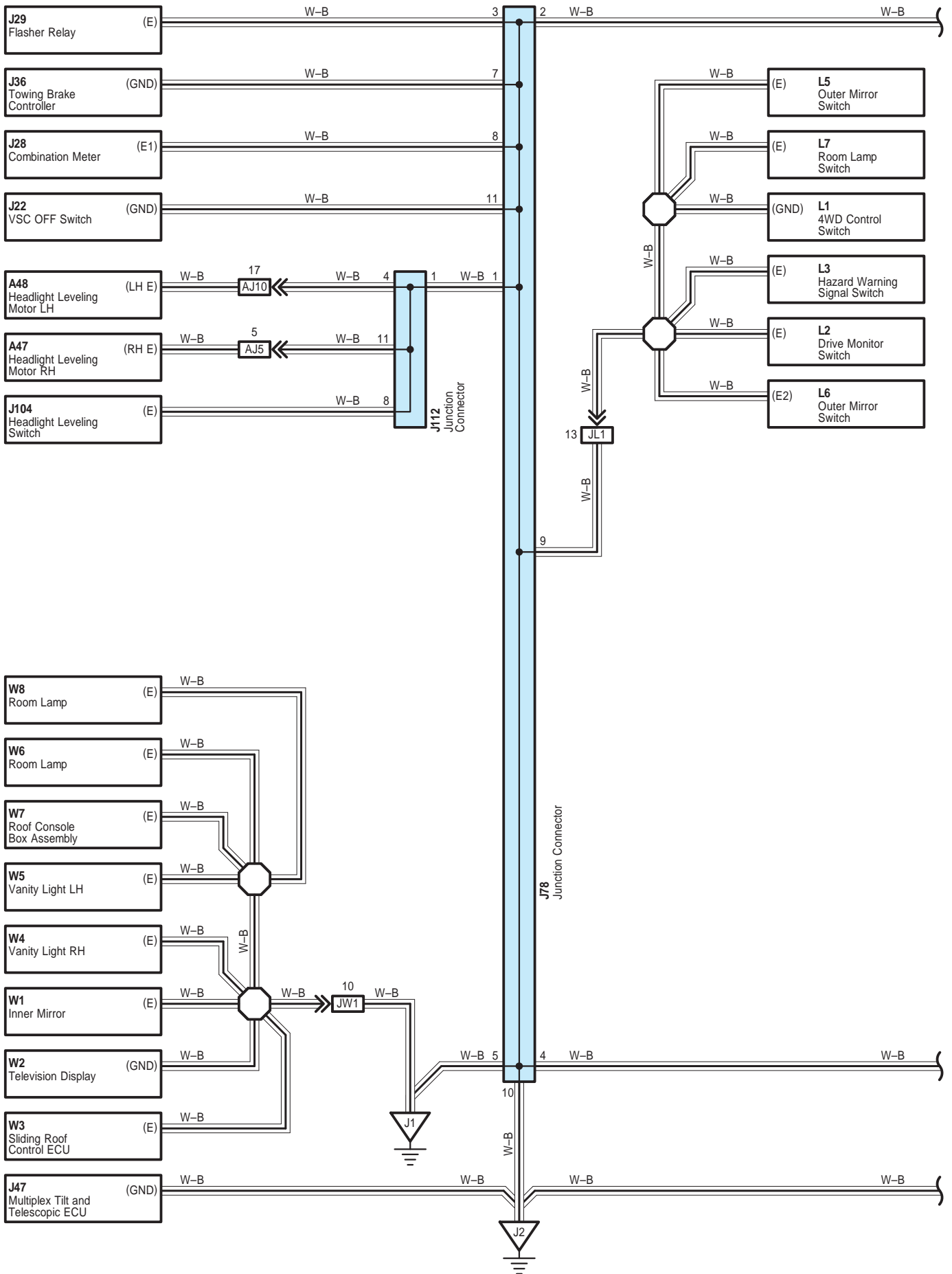

Ground Point

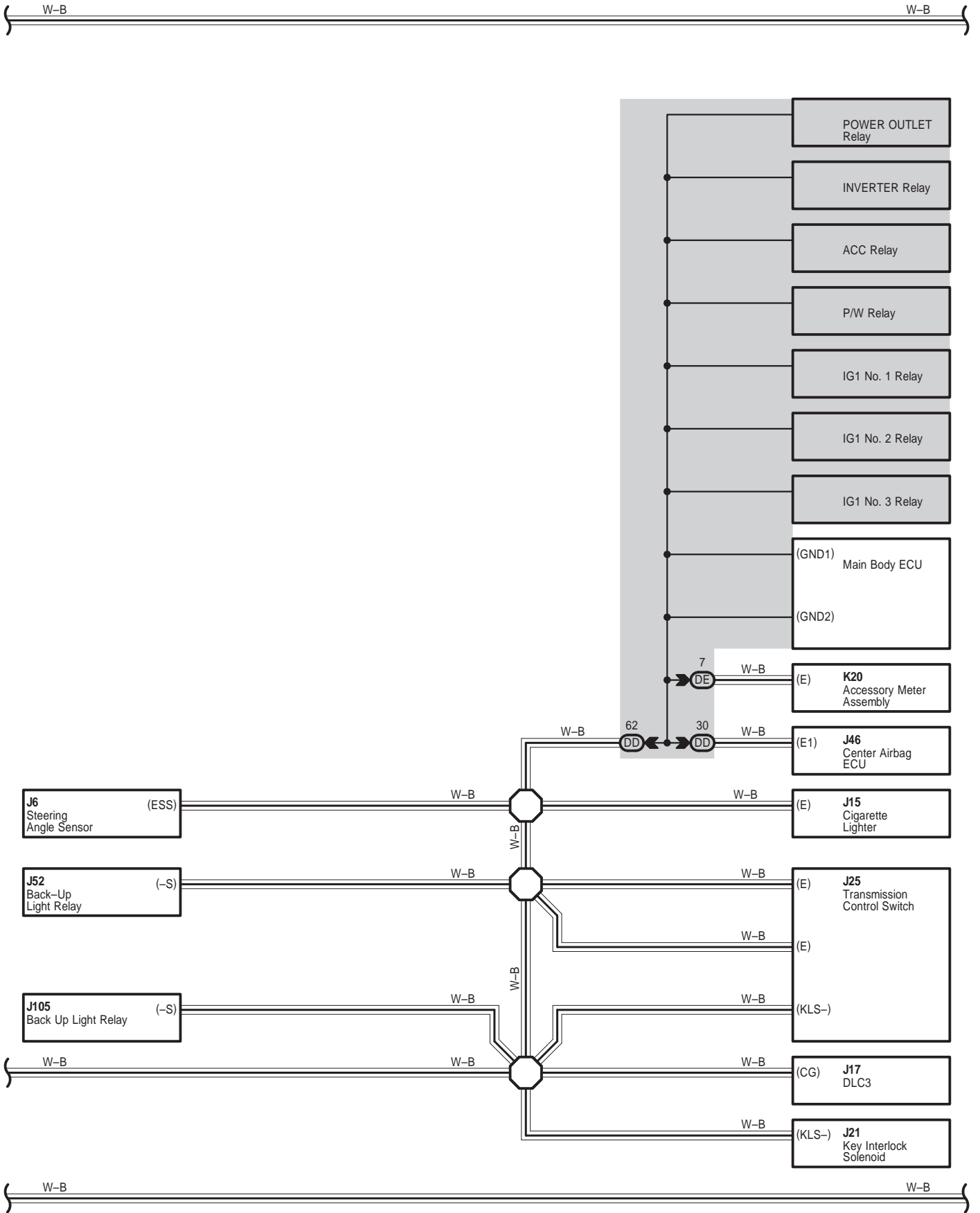

Ground Point

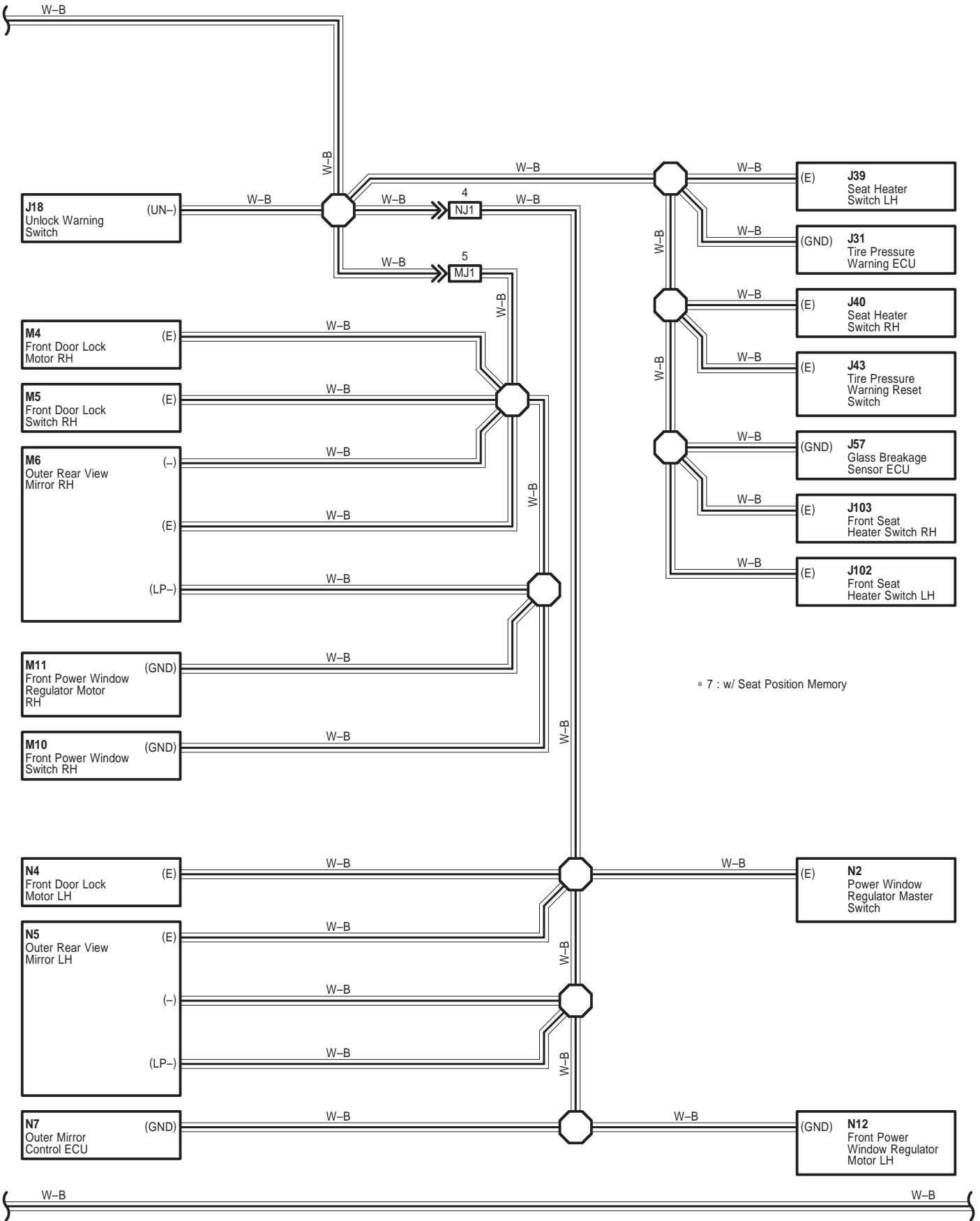

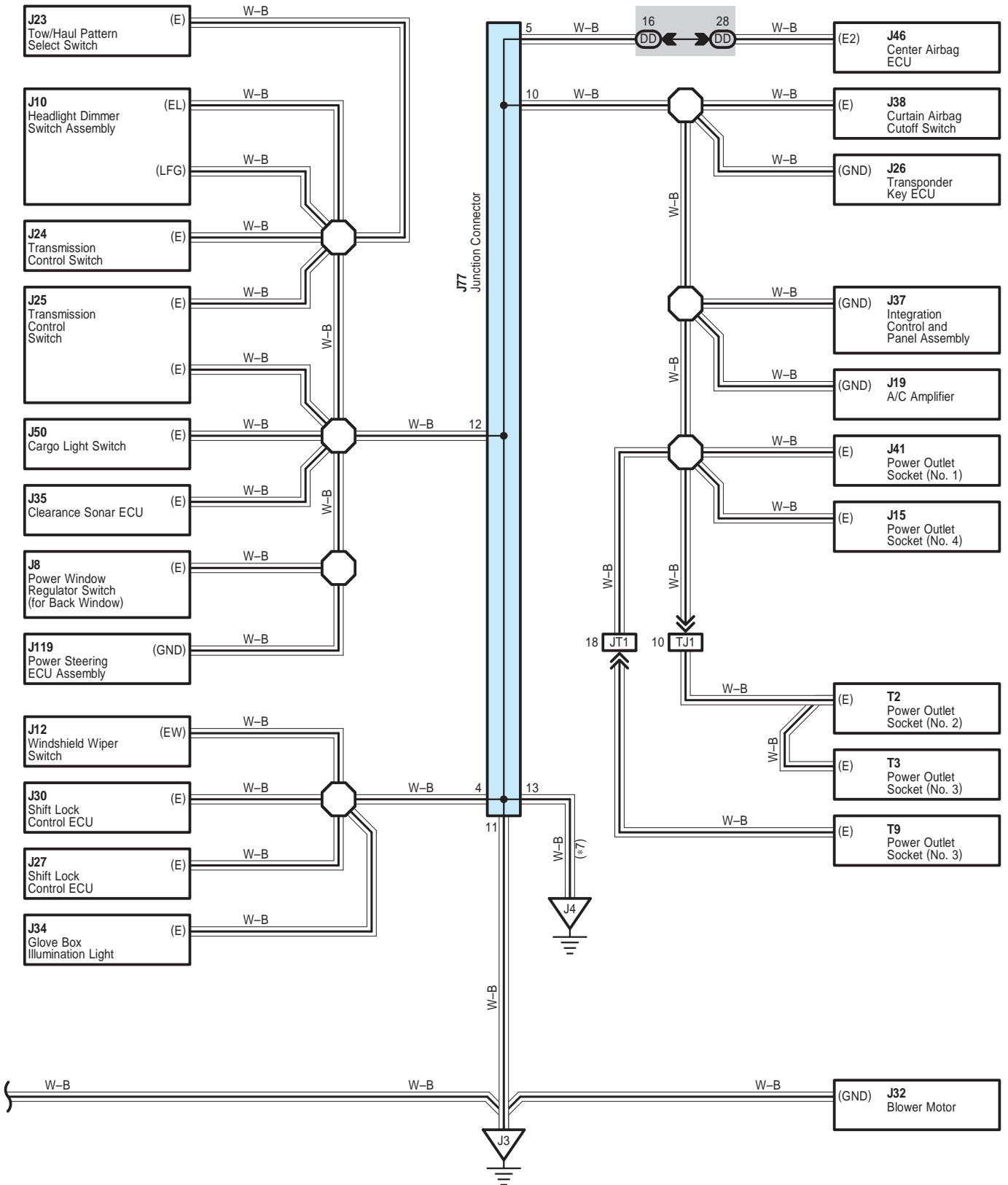

Ground Point

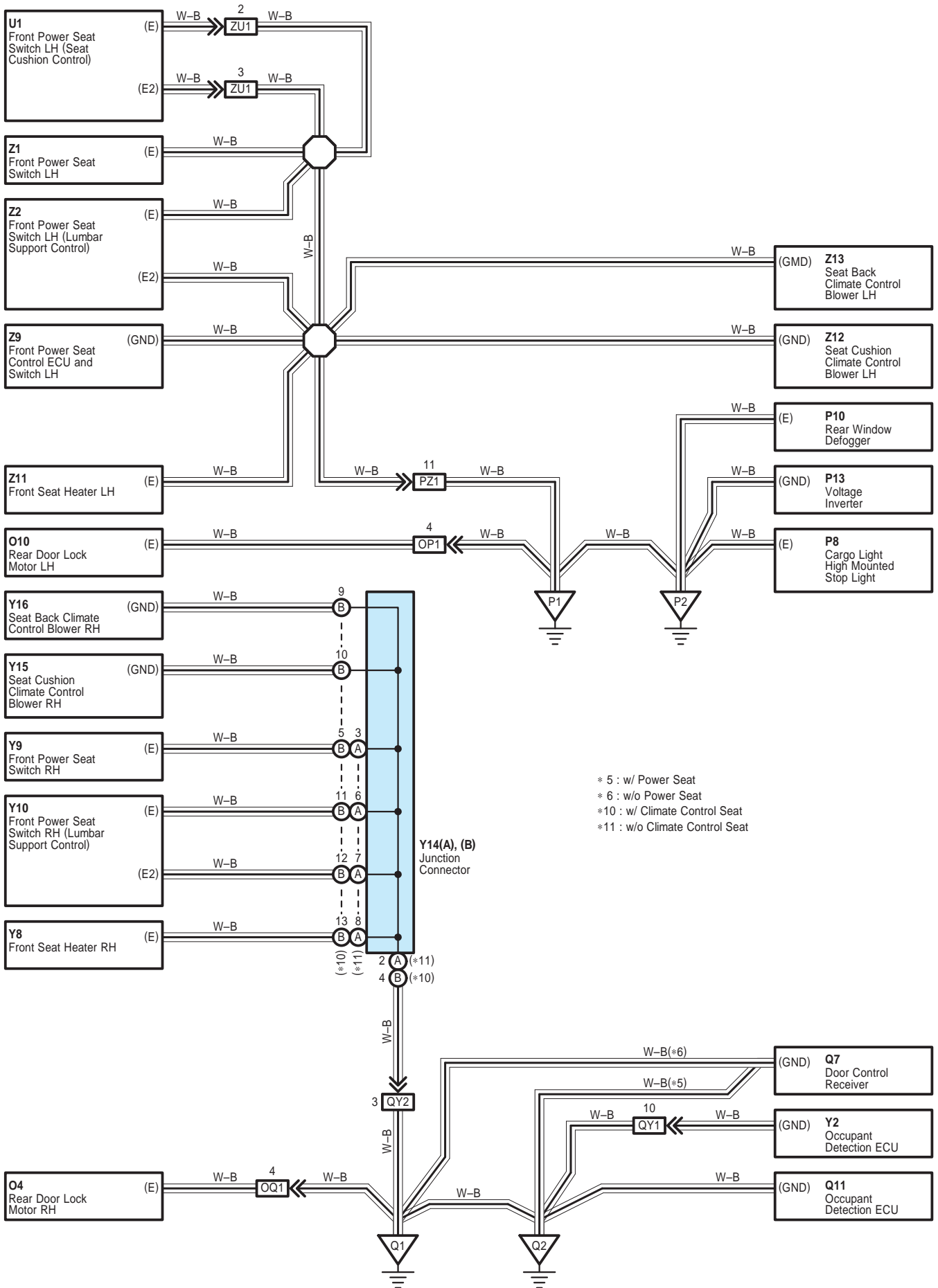

A 36

White

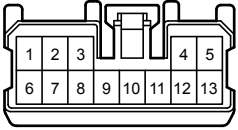

A 44

White

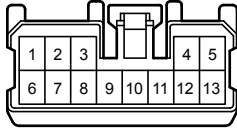

A 45

Blue

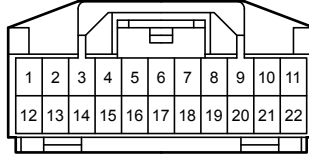

D 71

White

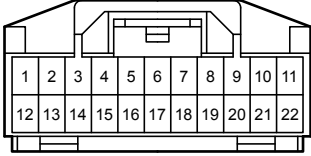

D 73

Blue

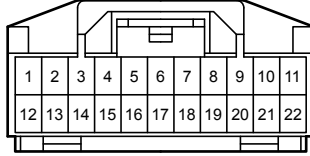

J 77

Gray

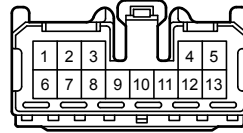

J 78

White

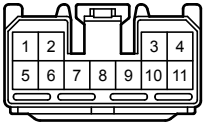

J 79

White

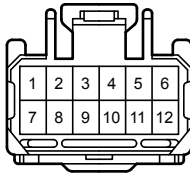

J 80

White

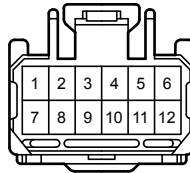

J112

White

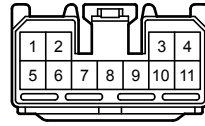

Y 14

White

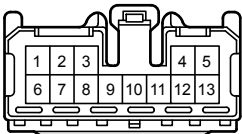

1A

White

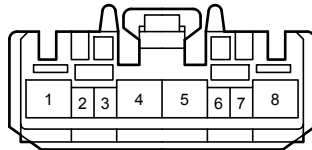

1B

White

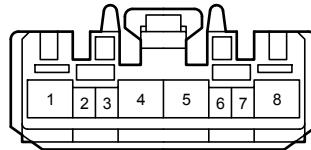

DD

White

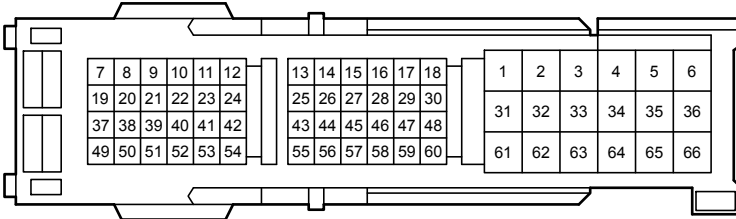

DE

White

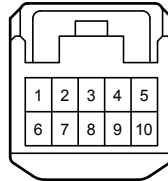

AJ3

White

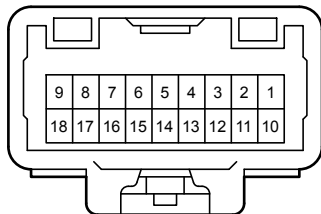
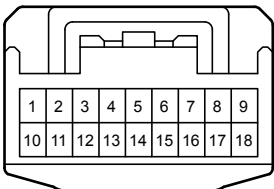



AJ5  
White

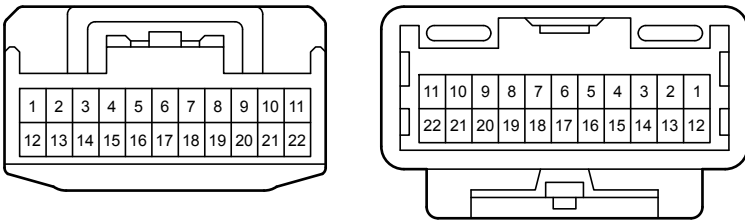

AJ10  
Gray

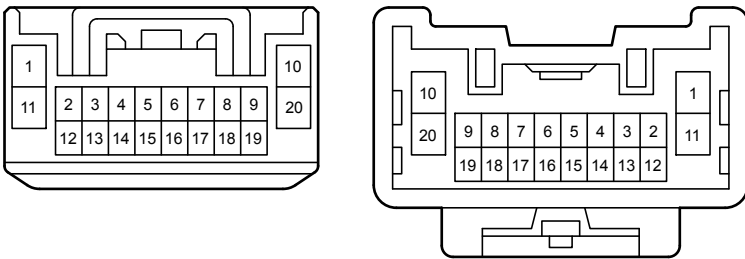

DA1  
White

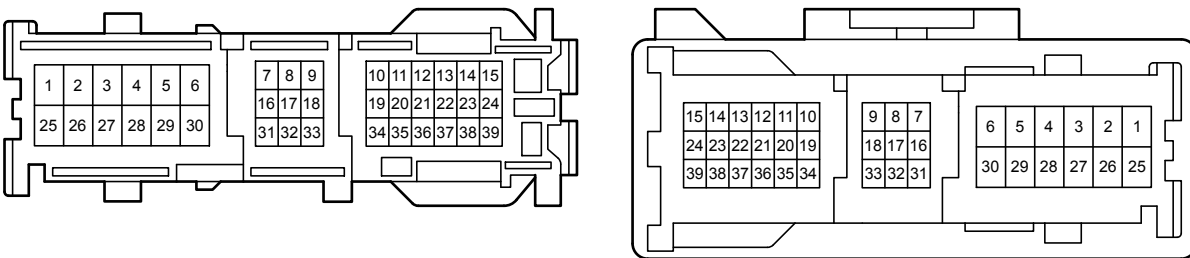

DG1  
Black

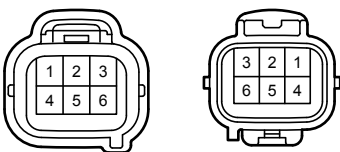

Da2

Gray Dark Gray

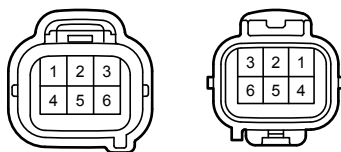

JL1  
White

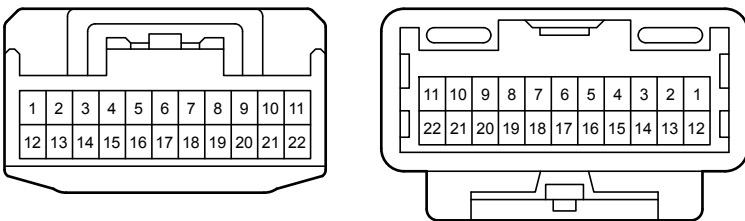

JT1  
Black

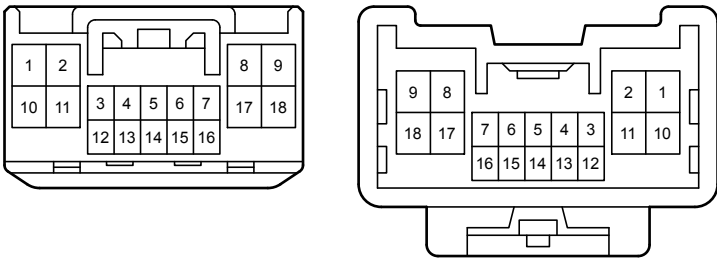

JW1  
White

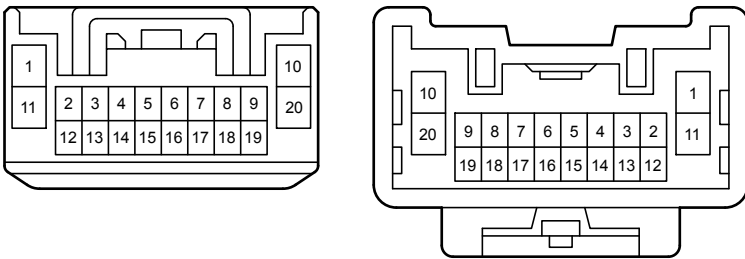

MJ1  
Blue

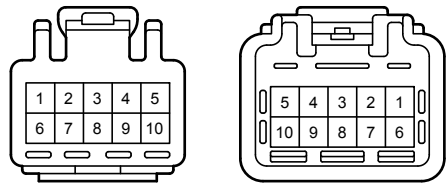

NJ1  
Blue

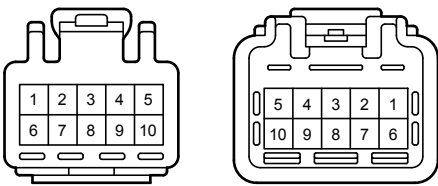

OP1  
White

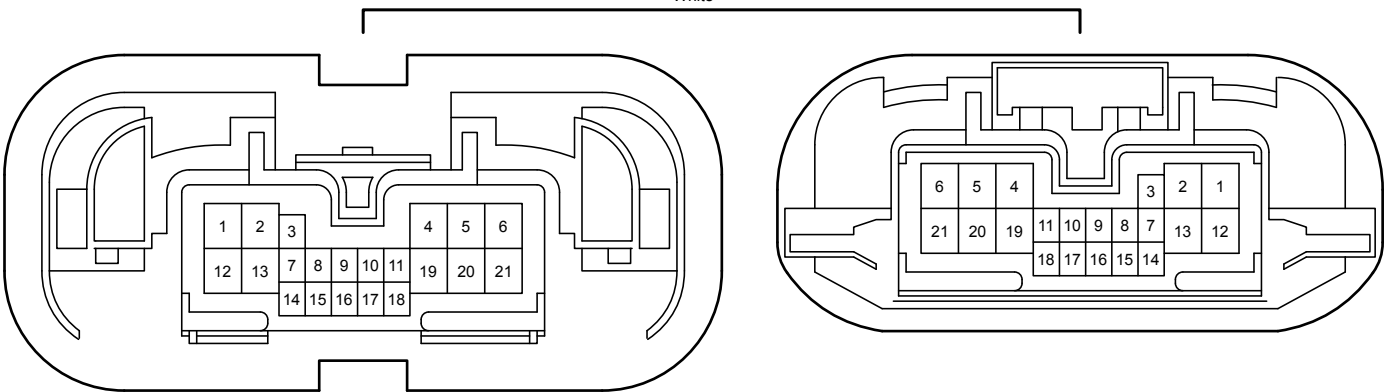

Ground Point

QO1  
White

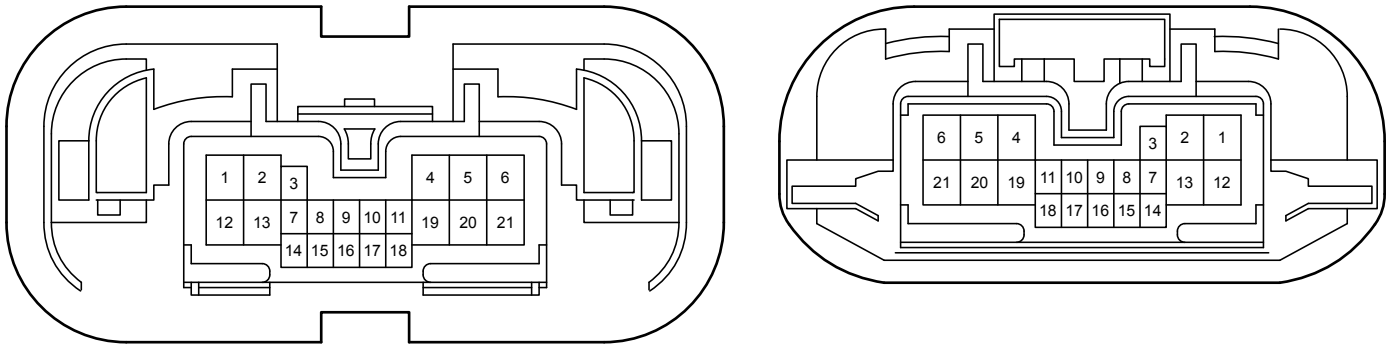

PZ1  
White

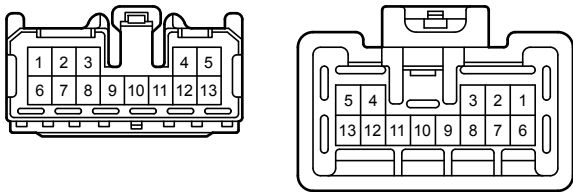

QY1  
White

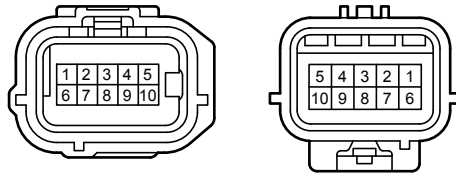

QY2  
White

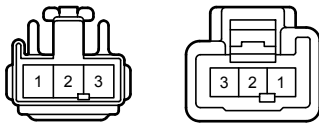

RA1  
White

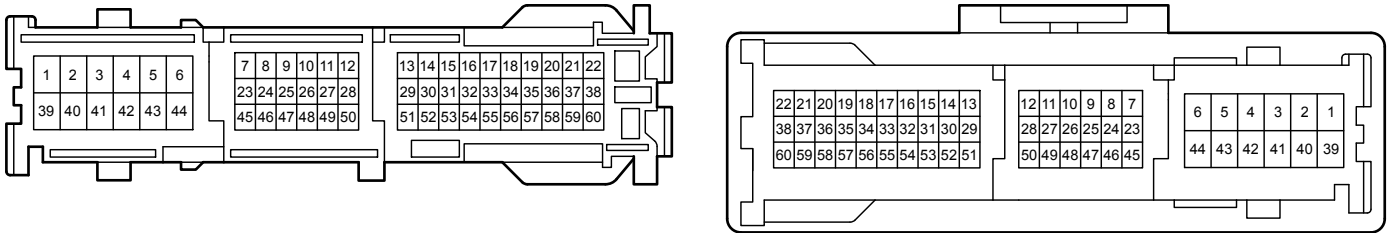

RA2  
White

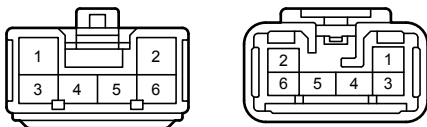

RA4  
White

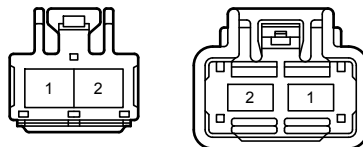

Ground Point

RV1  
Gray

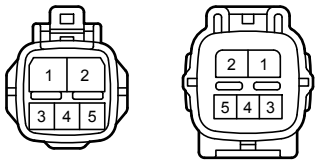

TJ1  
White

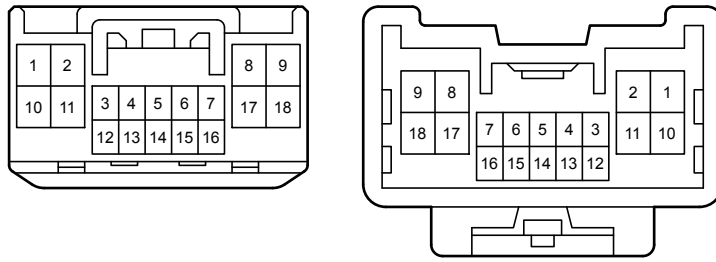

ZU1  
White

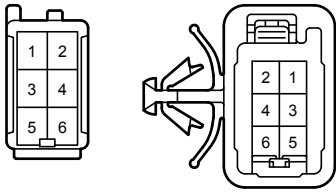

# Headlight Beam Level Control

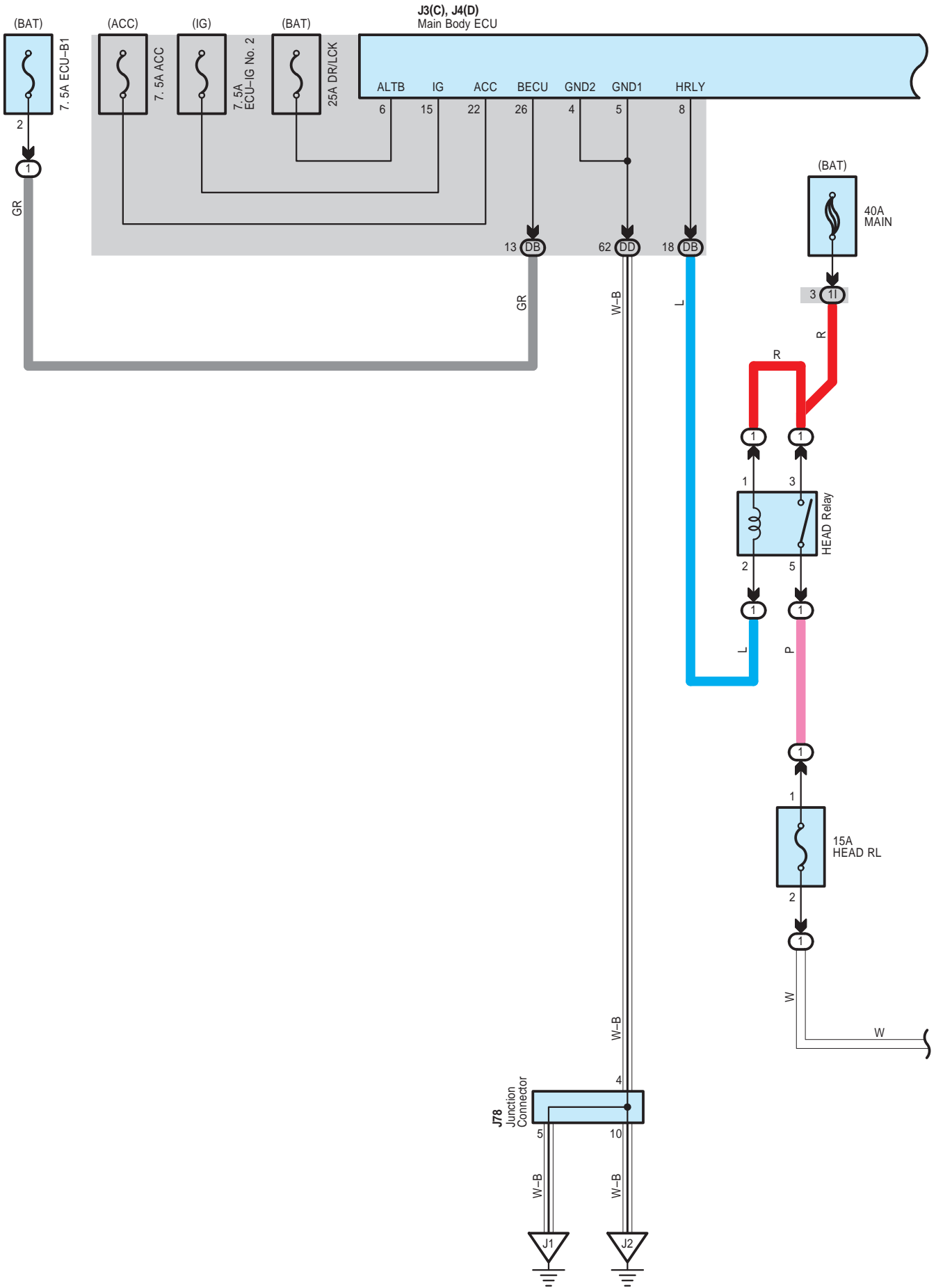

# Headlight Beam Level Control

J3(C), J4(D)  
Main Body ECU

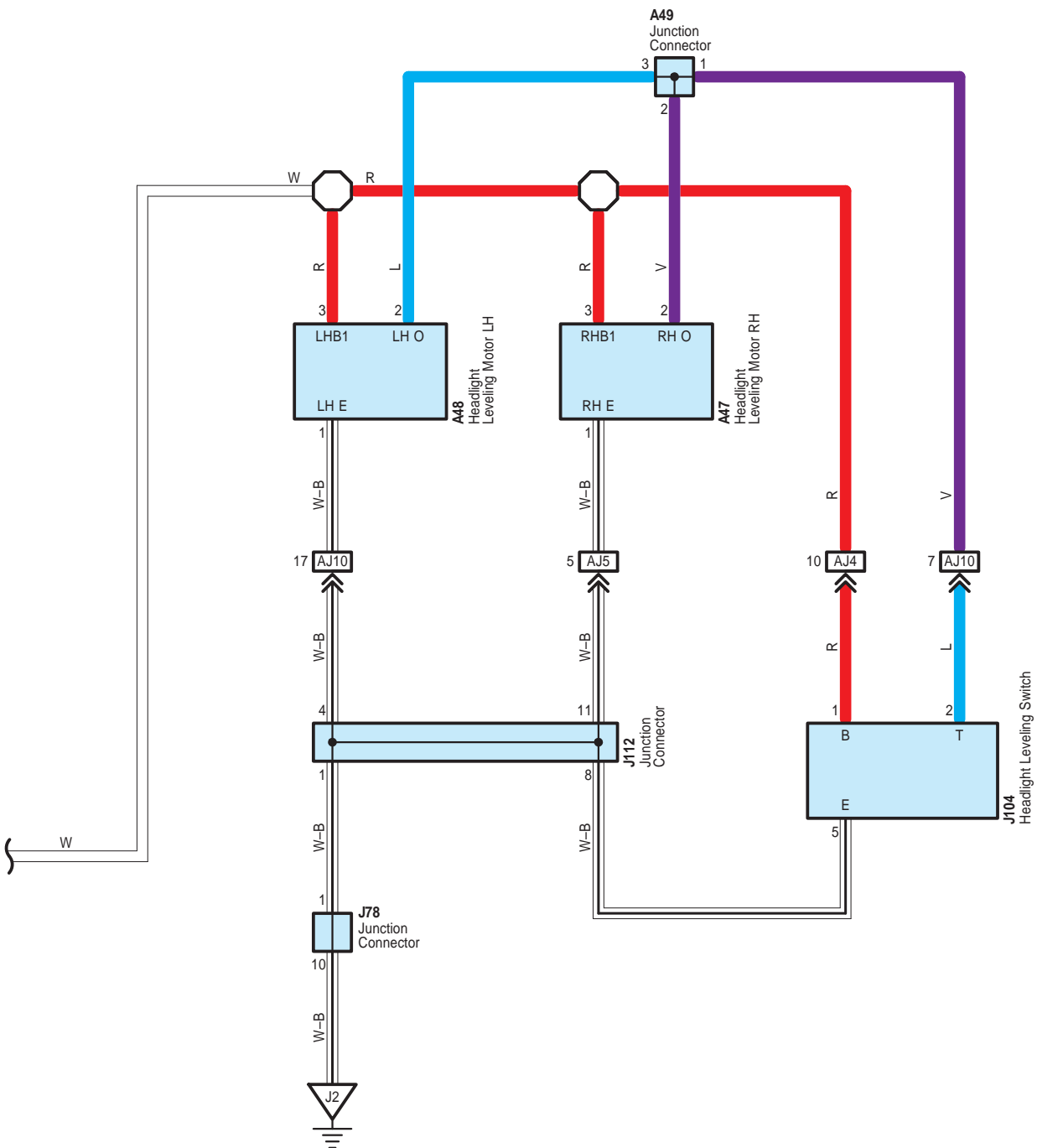
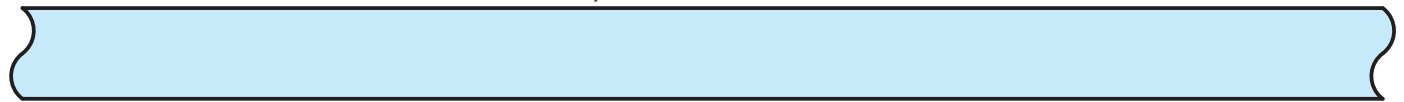

# Headlight Beam Level Control

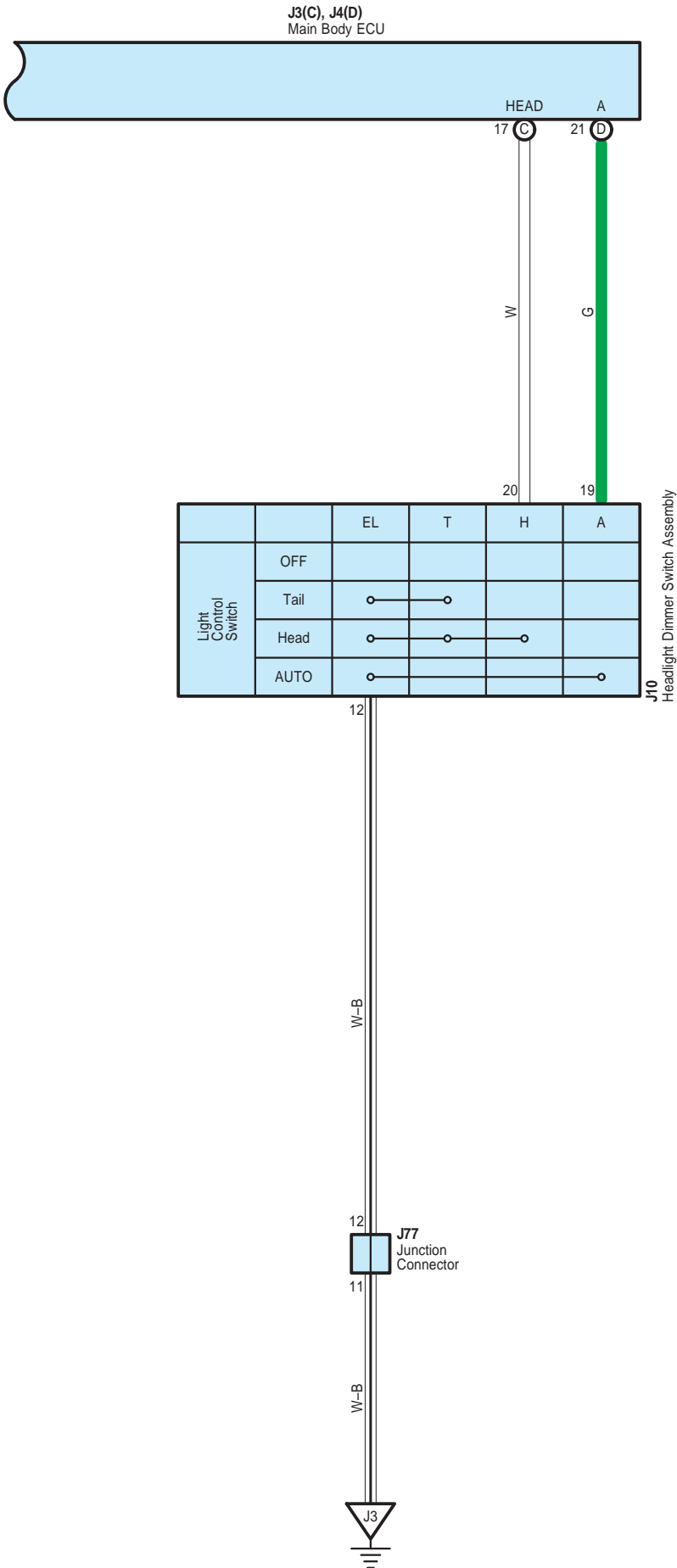





# Headlight Beam Level Control

AJ5  
White

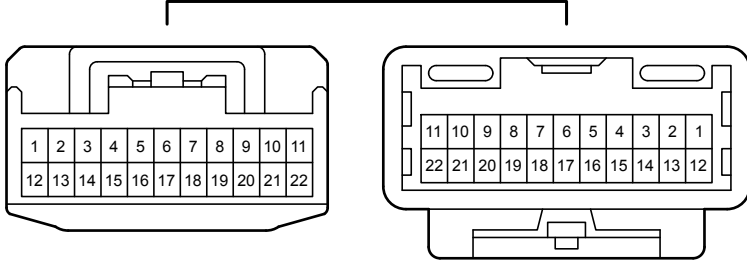

AJ10  
Gray

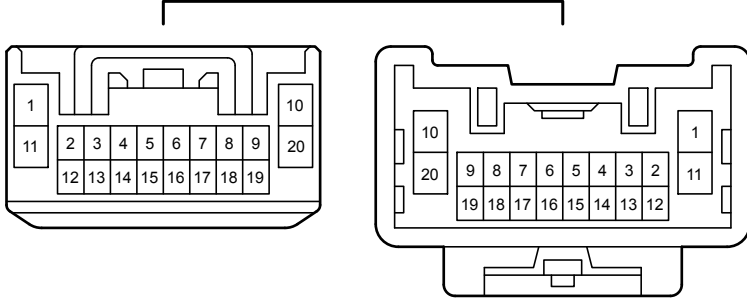

# Headlight

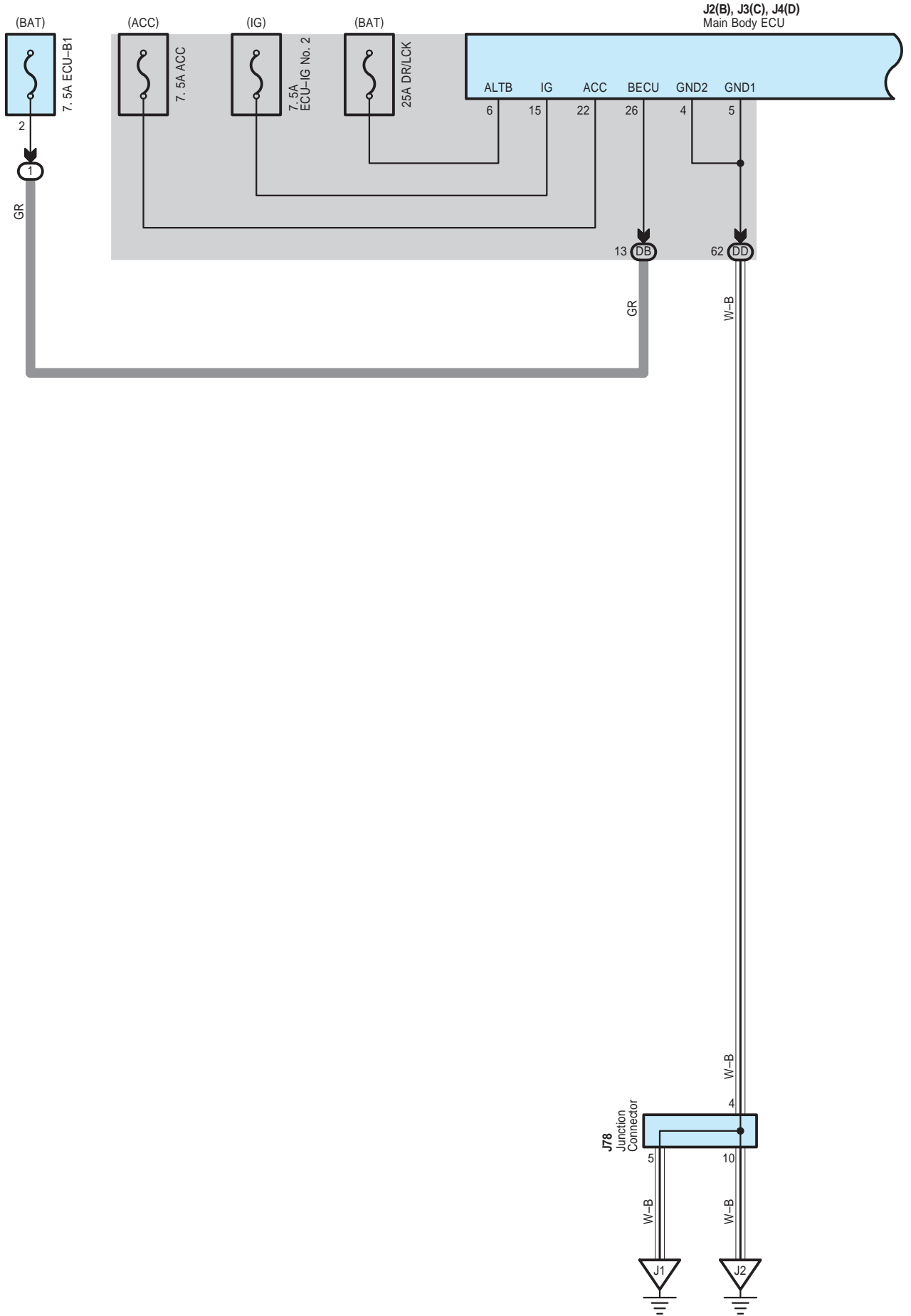

# Headlight

J2(B), J3(C), J4(D)  
Main Body ECU

A24(A), D74(B)  
Engine Control Module

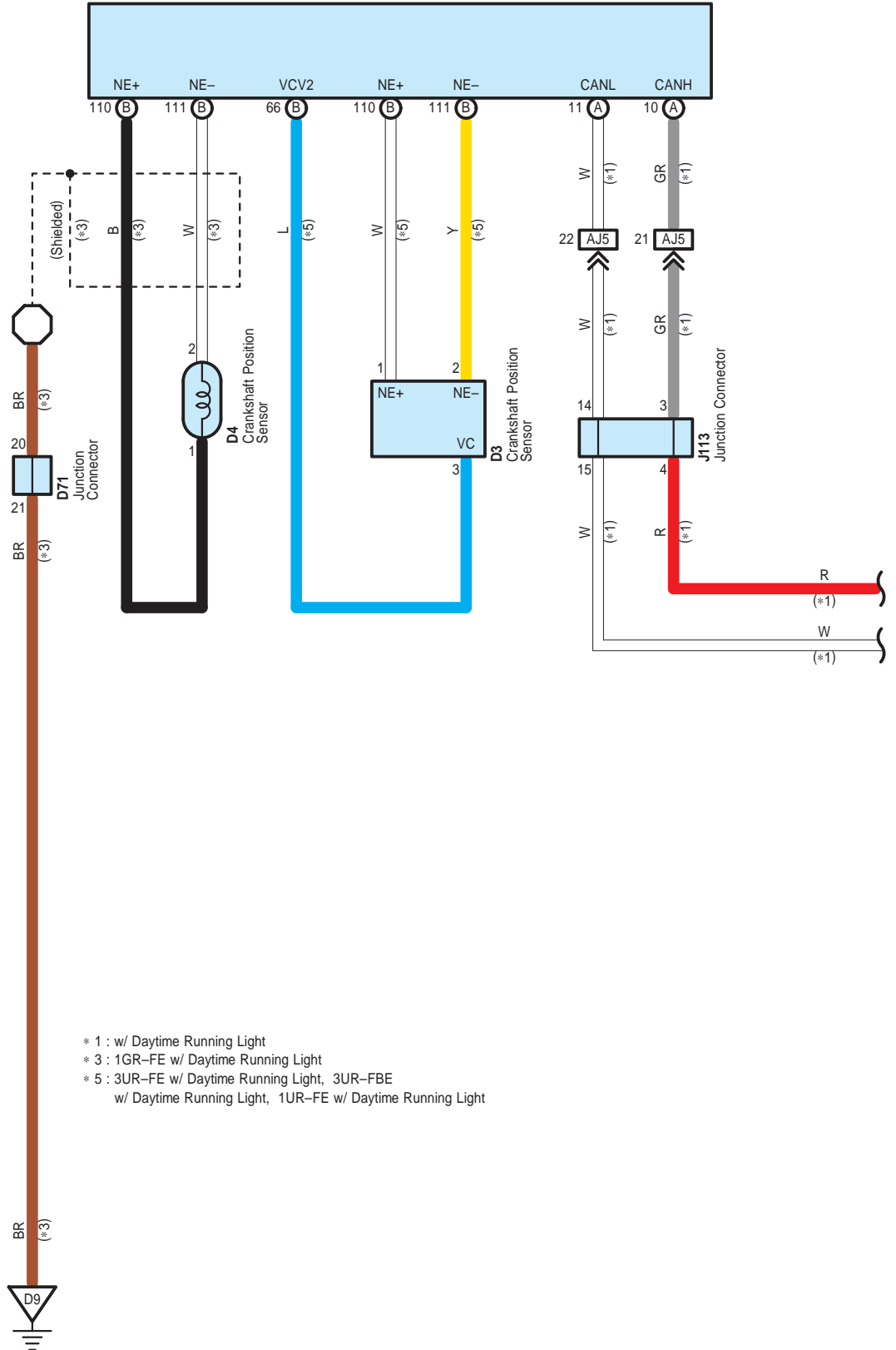

# Headlight

J2(B), J3(C), J4(D)  
Main Body ECU

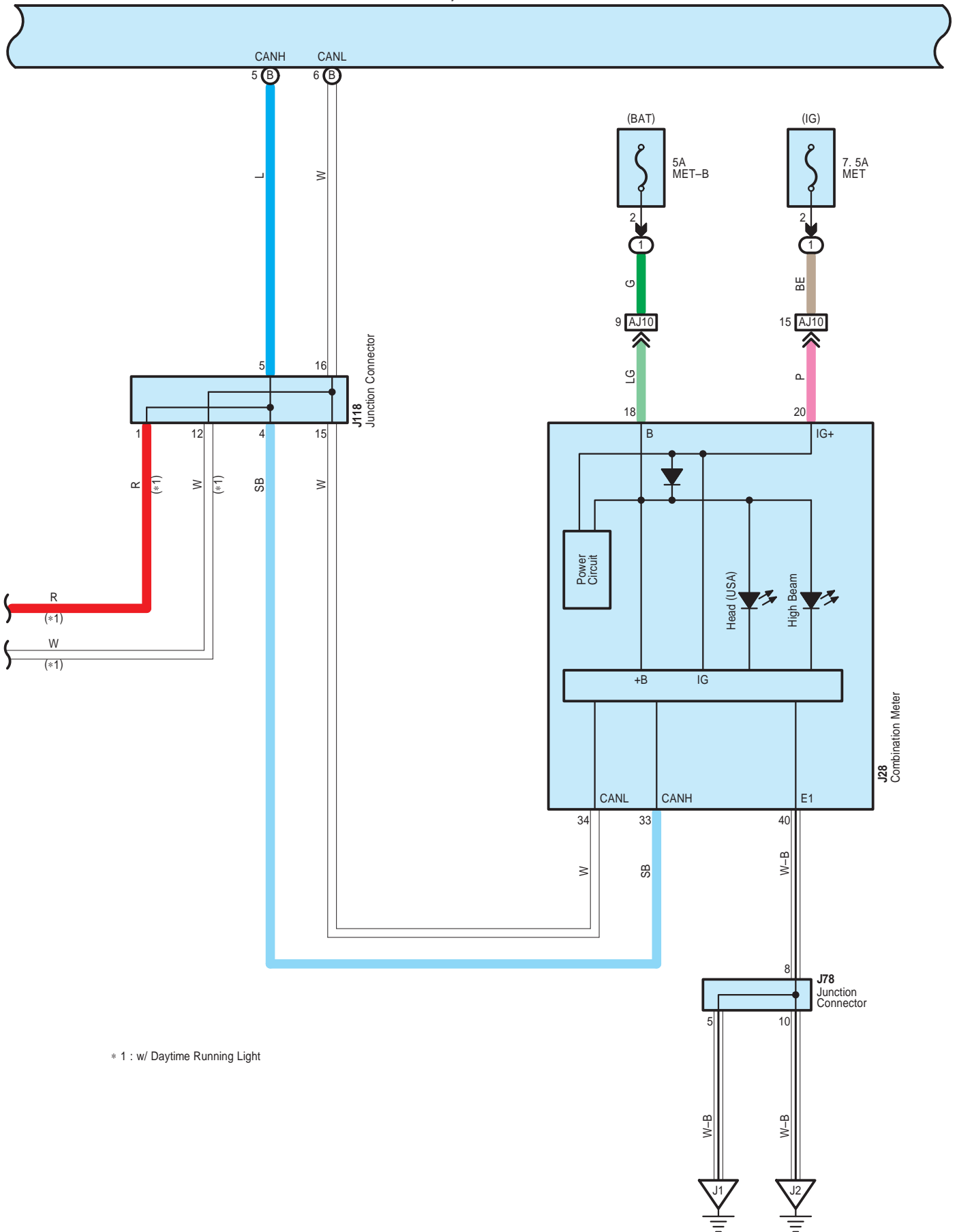

\* 1 : w/ Daytime Running Light

# Headlight

J2(B), J3(C), J4(D)  
Main Body ECU

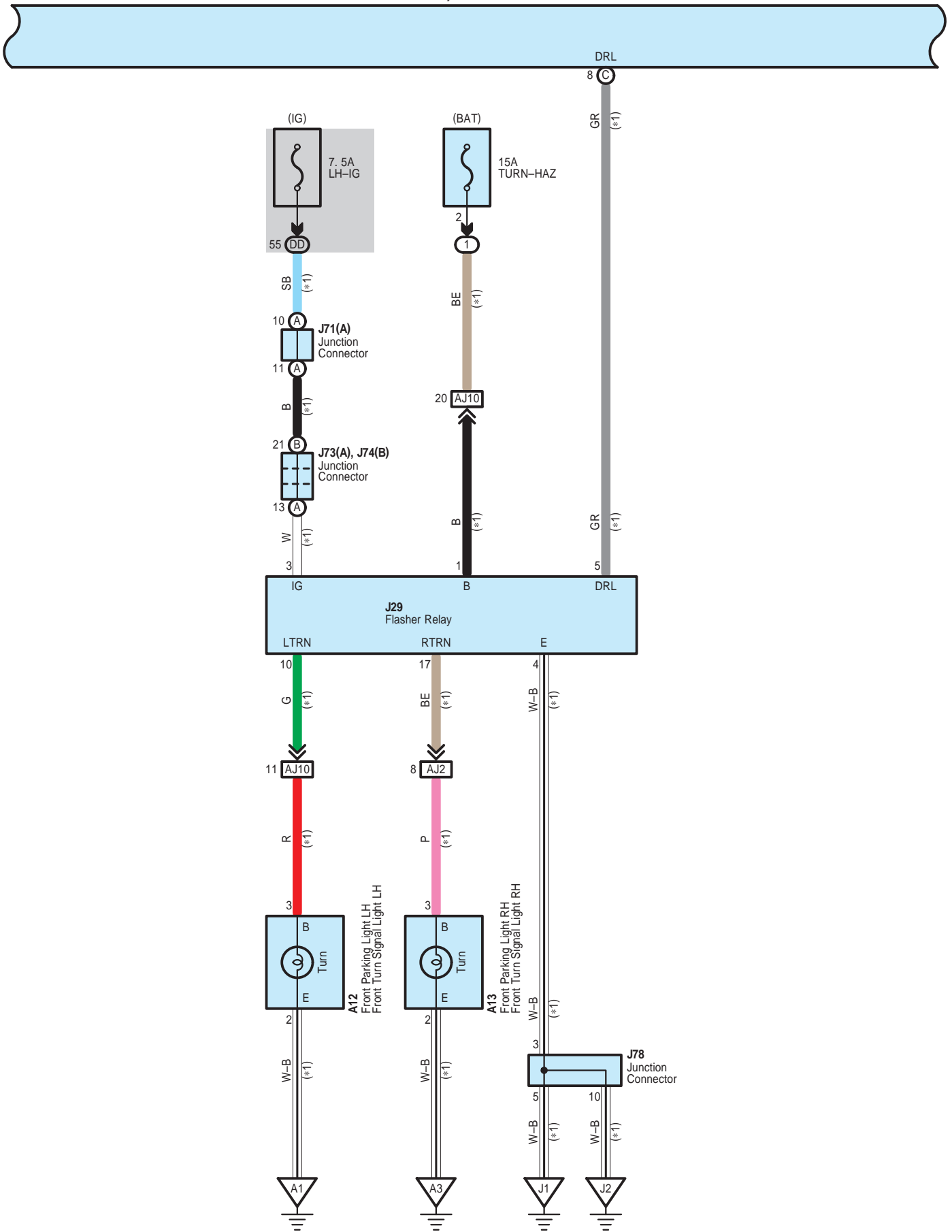

# Headlight

J2(B), J3(C), J4(D)  
Main Body ECU

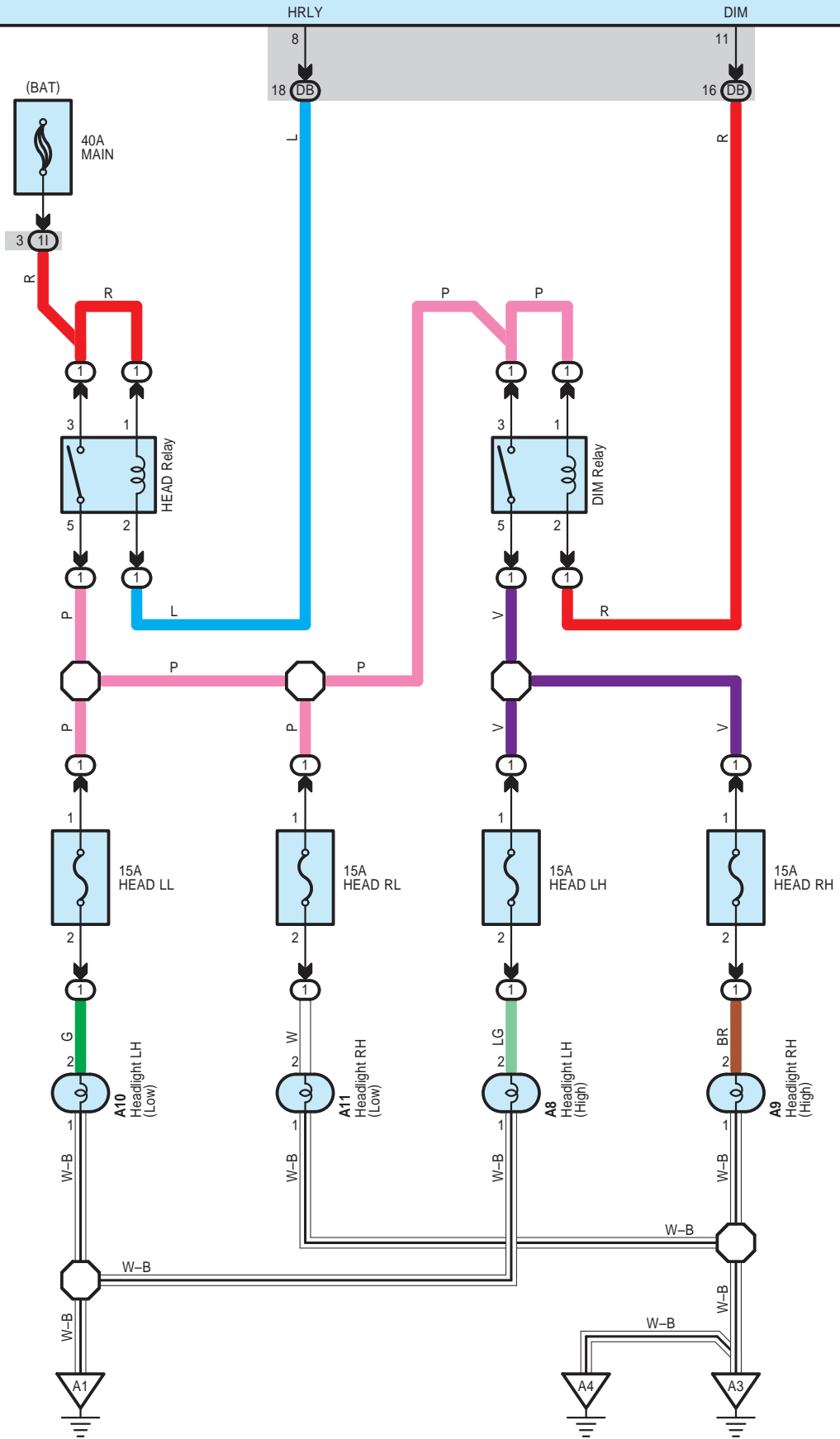

# Headlight

**J2(B), J3(C), J4(D)**  
Main Body ECU

\* 1 : w/ Daytime Running Light  
\* 4 : w/ Seat Position Memory

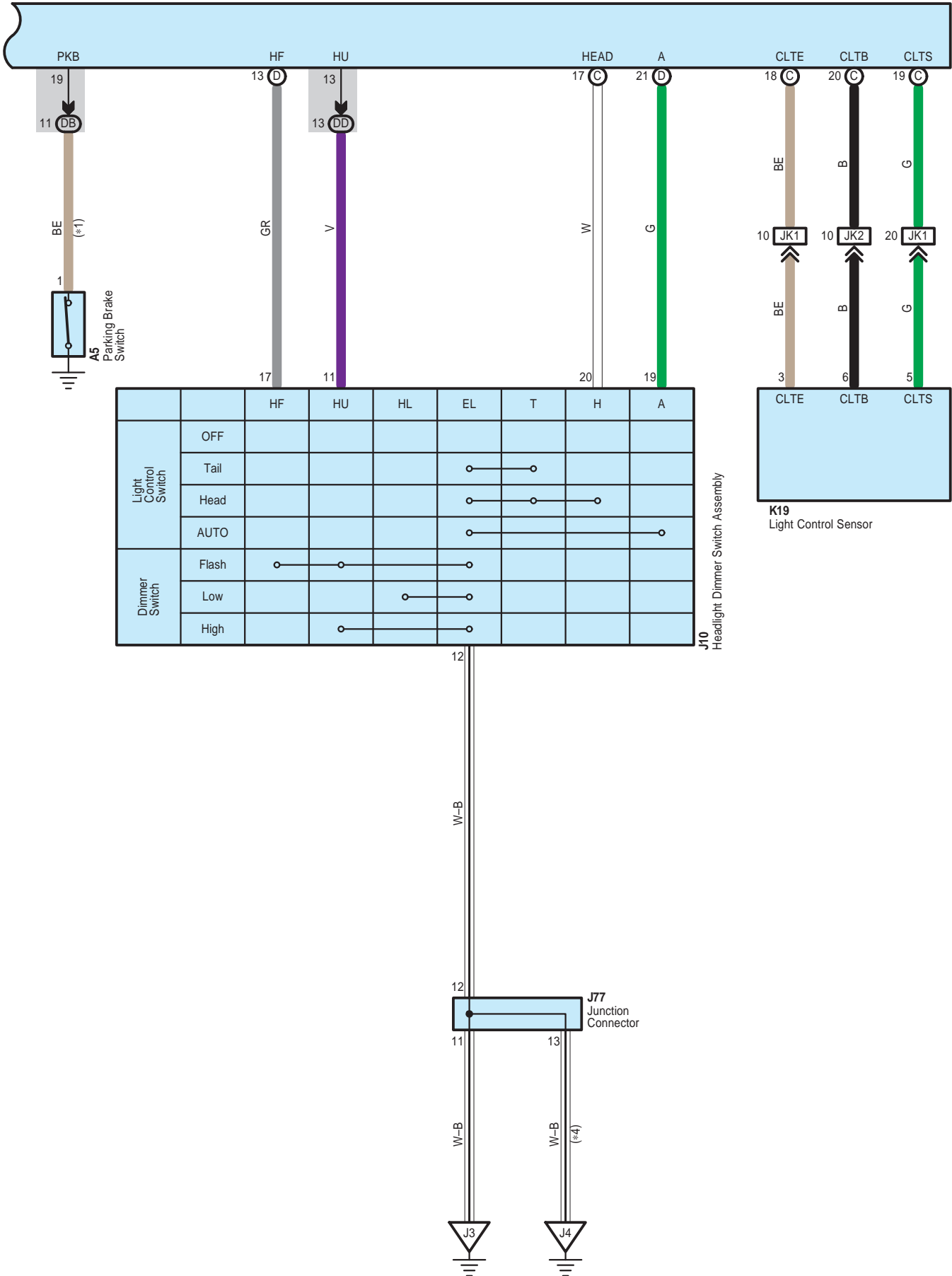

# Headlight

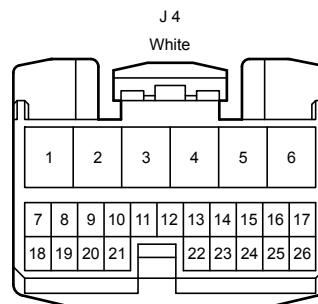
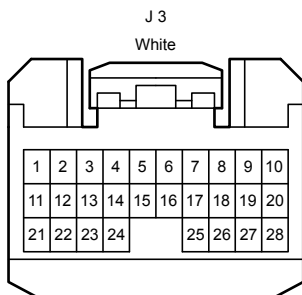
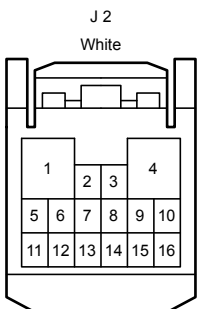
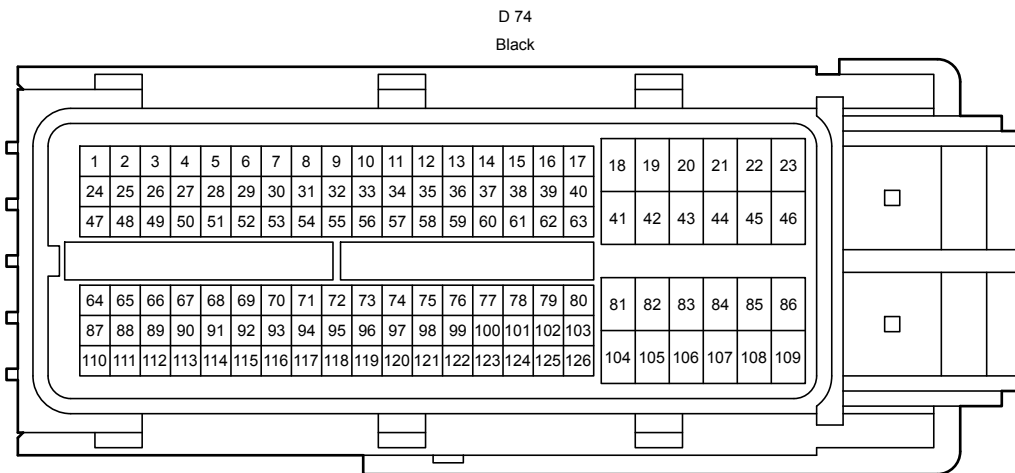
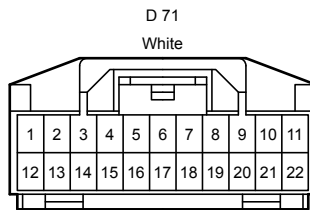
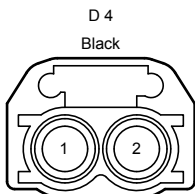
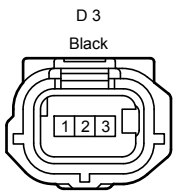
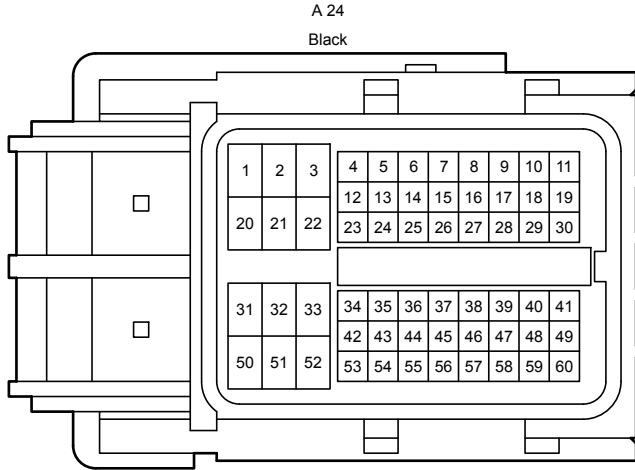
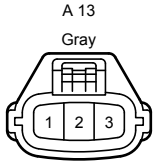
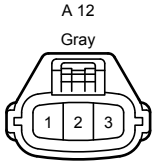
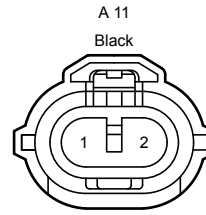
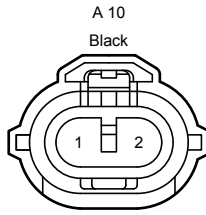
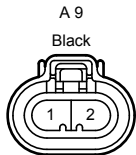
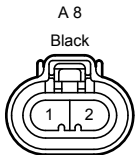



# Headlight

J 10  
White

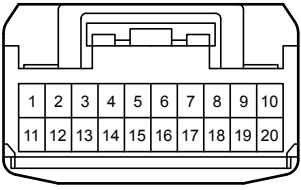

J 28  
White

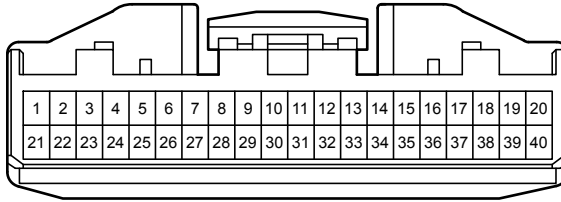

J 29  
White

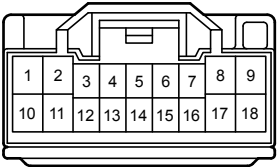

J 71  
Black

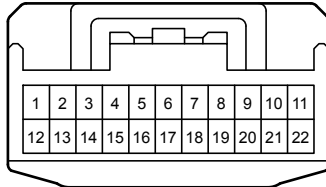

J 73  
Black

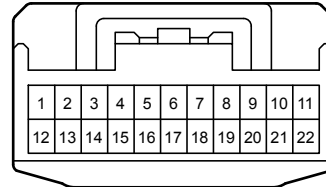

J 74  
Black

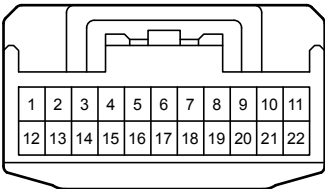

J 77  
Gray

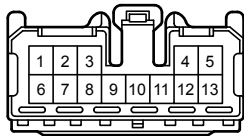

J 78  
White

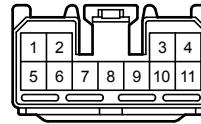

J113  
Gray

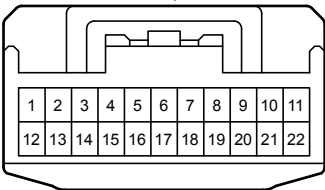

J118  
Gray

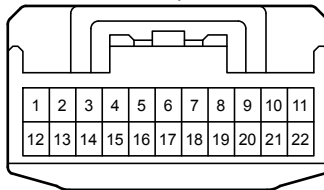

K 19  
Black

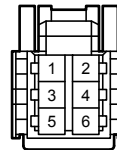

(11)  
White

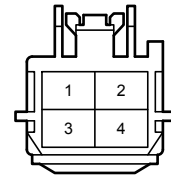

(DB)  
White

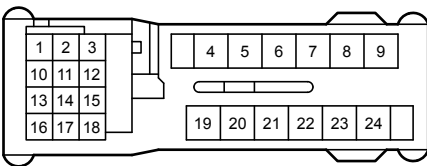

(DD)  
White

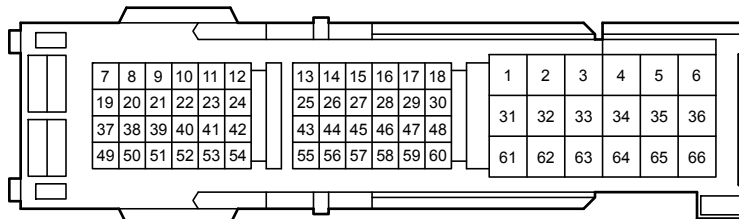

AJ2  
White

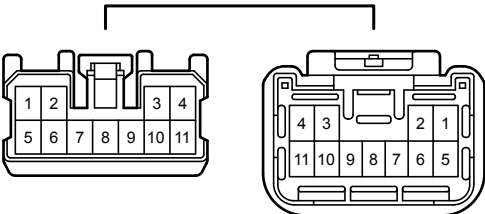

AJ5  
White

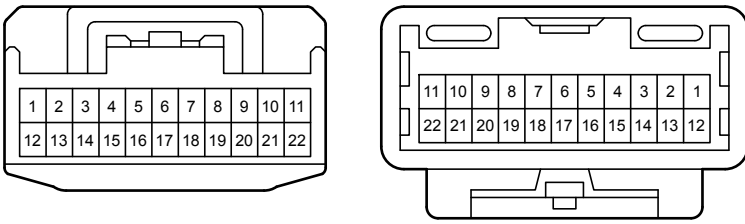

AJ10  
Gray

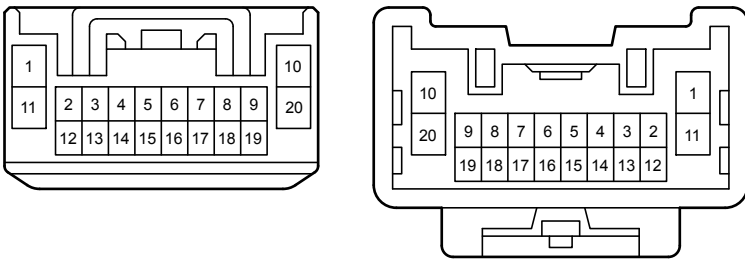

JK1  
White

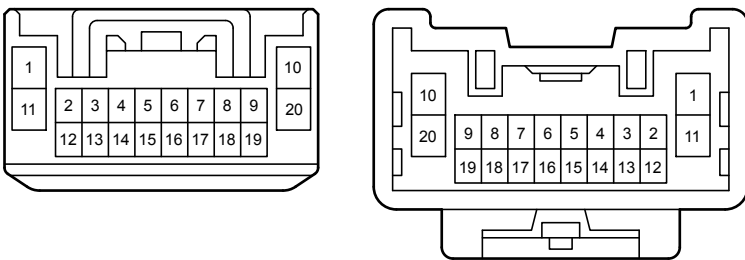

JK2  
White

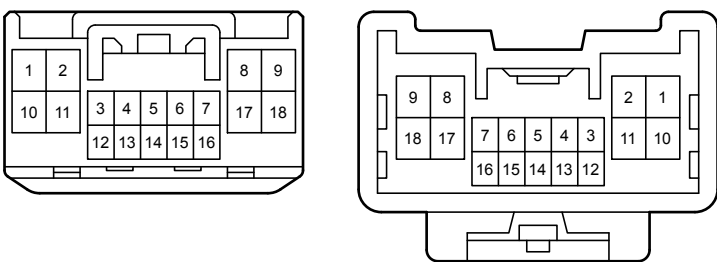

# Horn

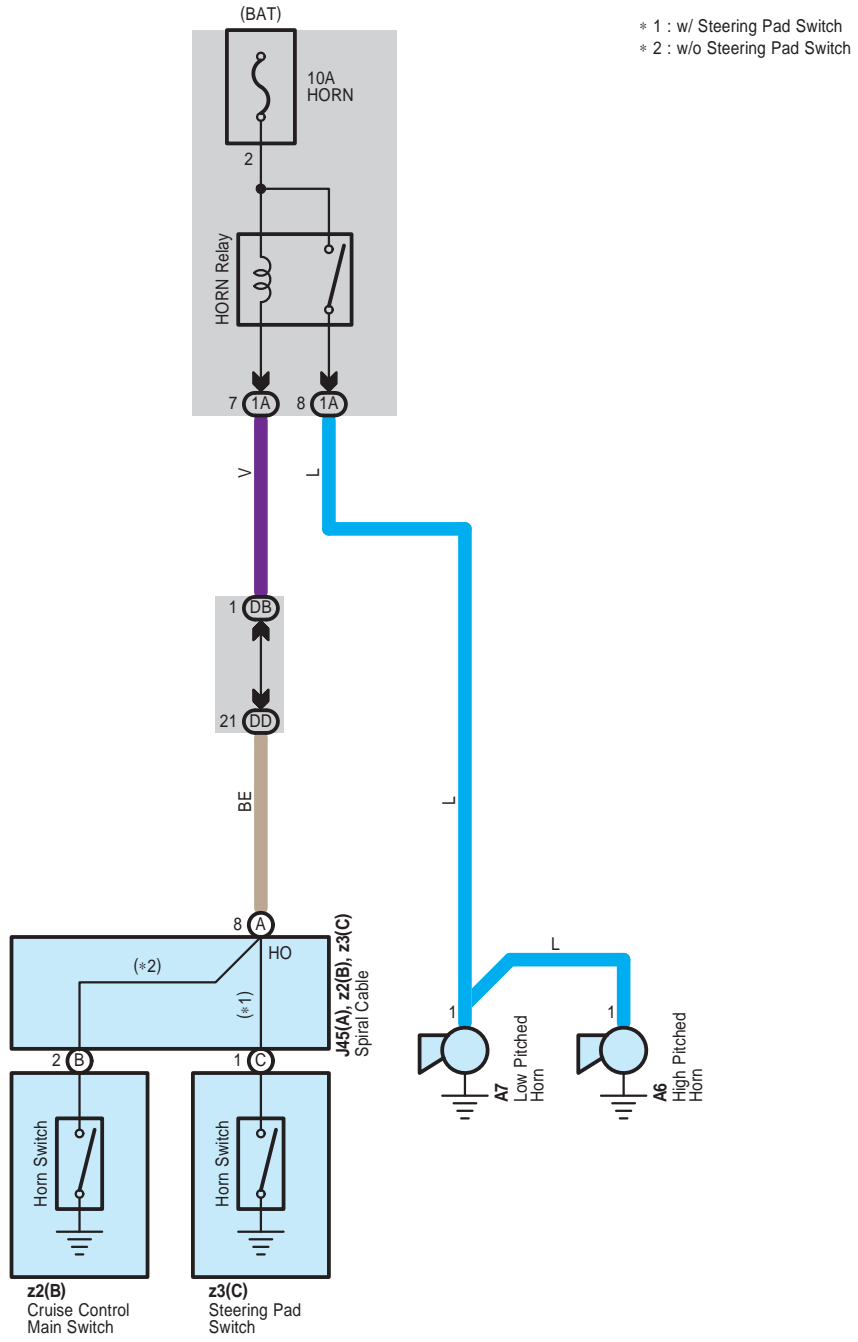

Horn

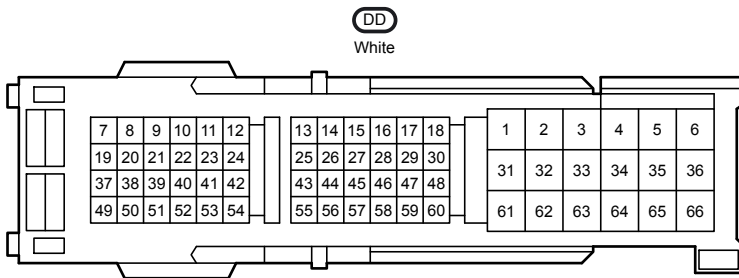
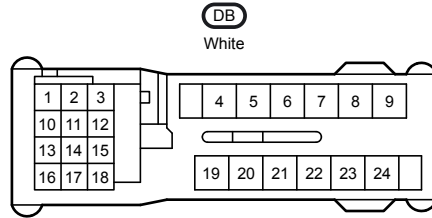
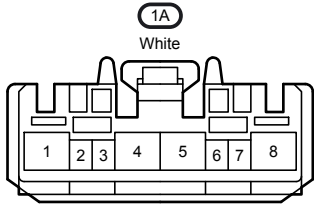
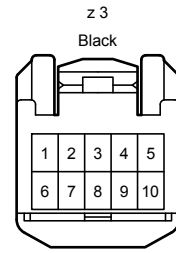
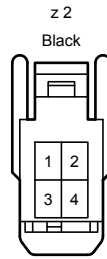
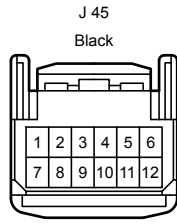
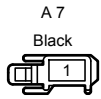
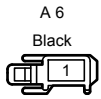

# Interior Light

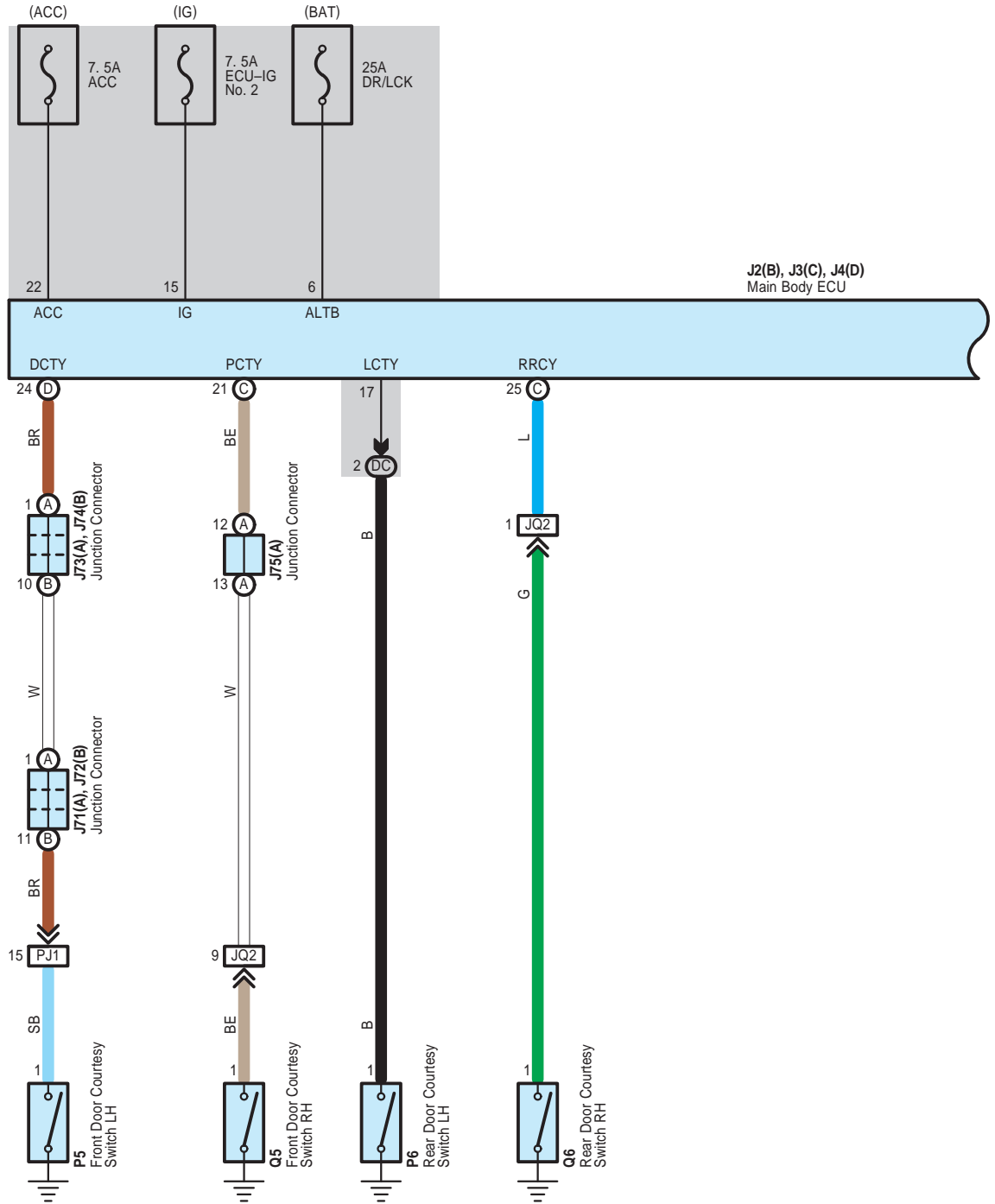

# Interior Light

- \* 1 : w/ Engine Immobiliser System
- \* 2 : w/o Engine Immobiliser System
- \* 3 : Except Regular Cab
- \* 4 : Regular Cab

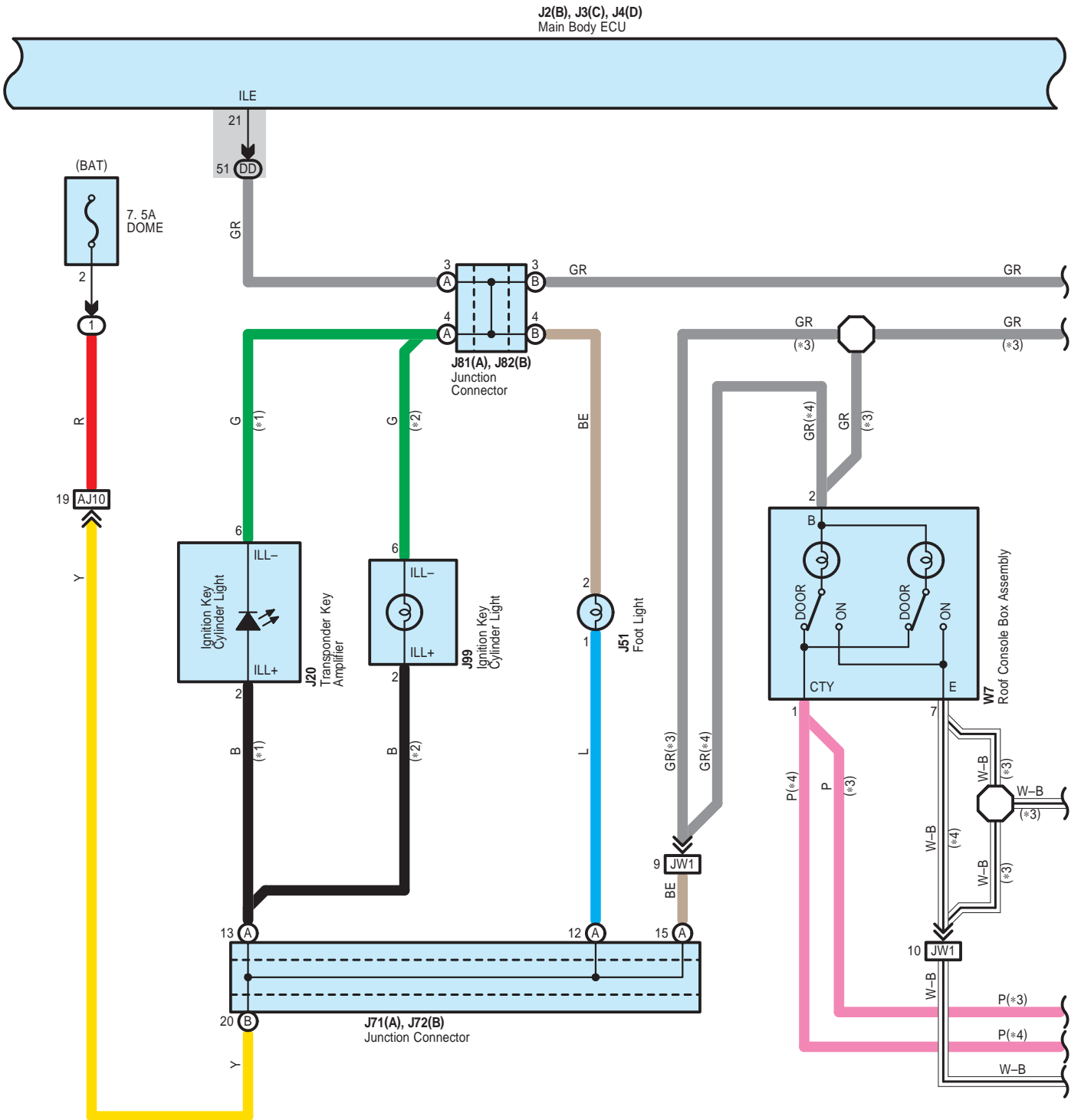

# Interior Light

- \* 3 : Except Regular Cab
- \* 4 : Regular Cab
- \* 5 : w/ Seat Position Memory
- \* 6 : w/ Rear Seat Entertainment System
- \* 7 : w/o Rear Seat Entertainment System

**J2(B), J3(C), J4(D)**  
Main Body ECU

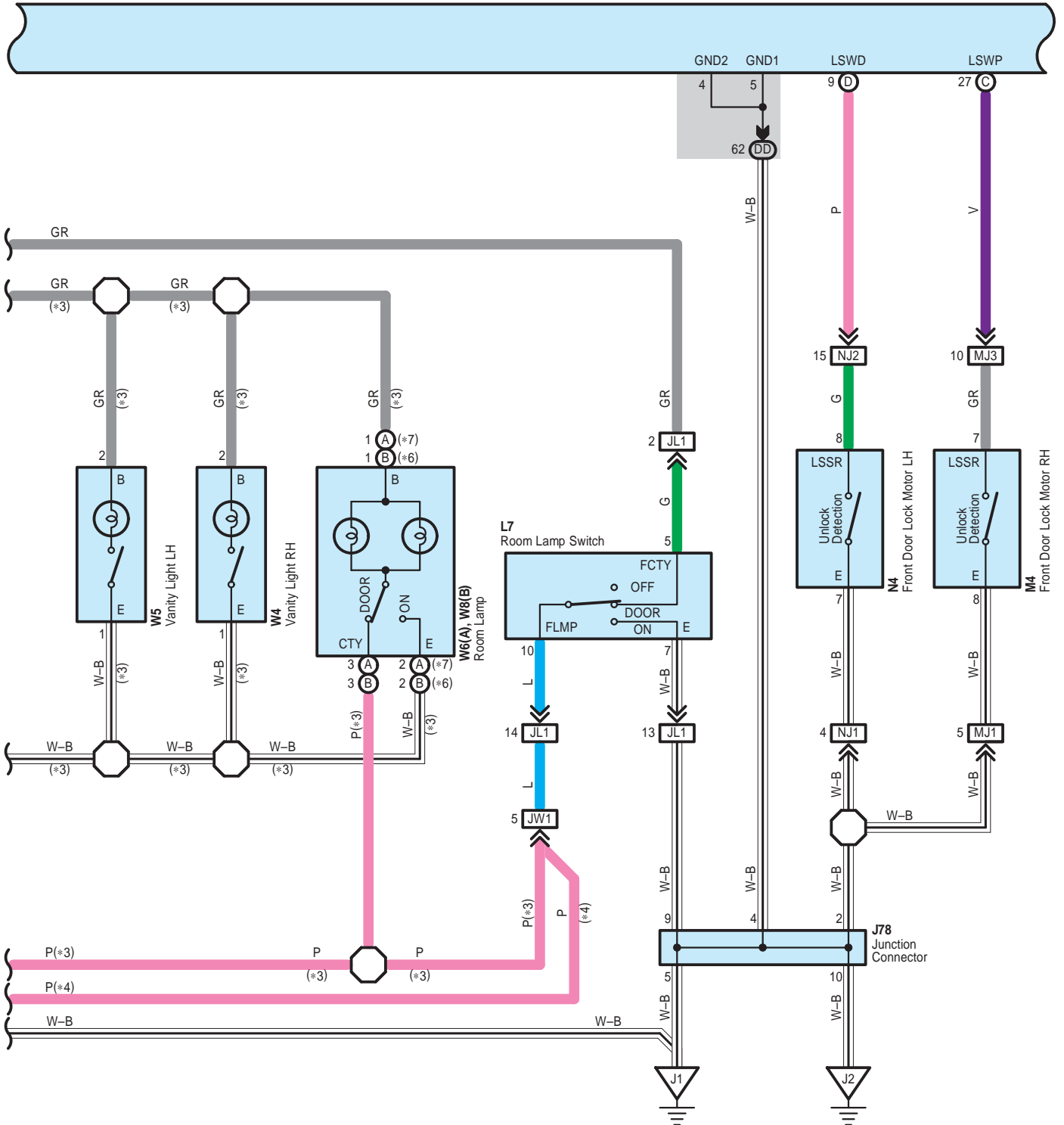

# Interior Light

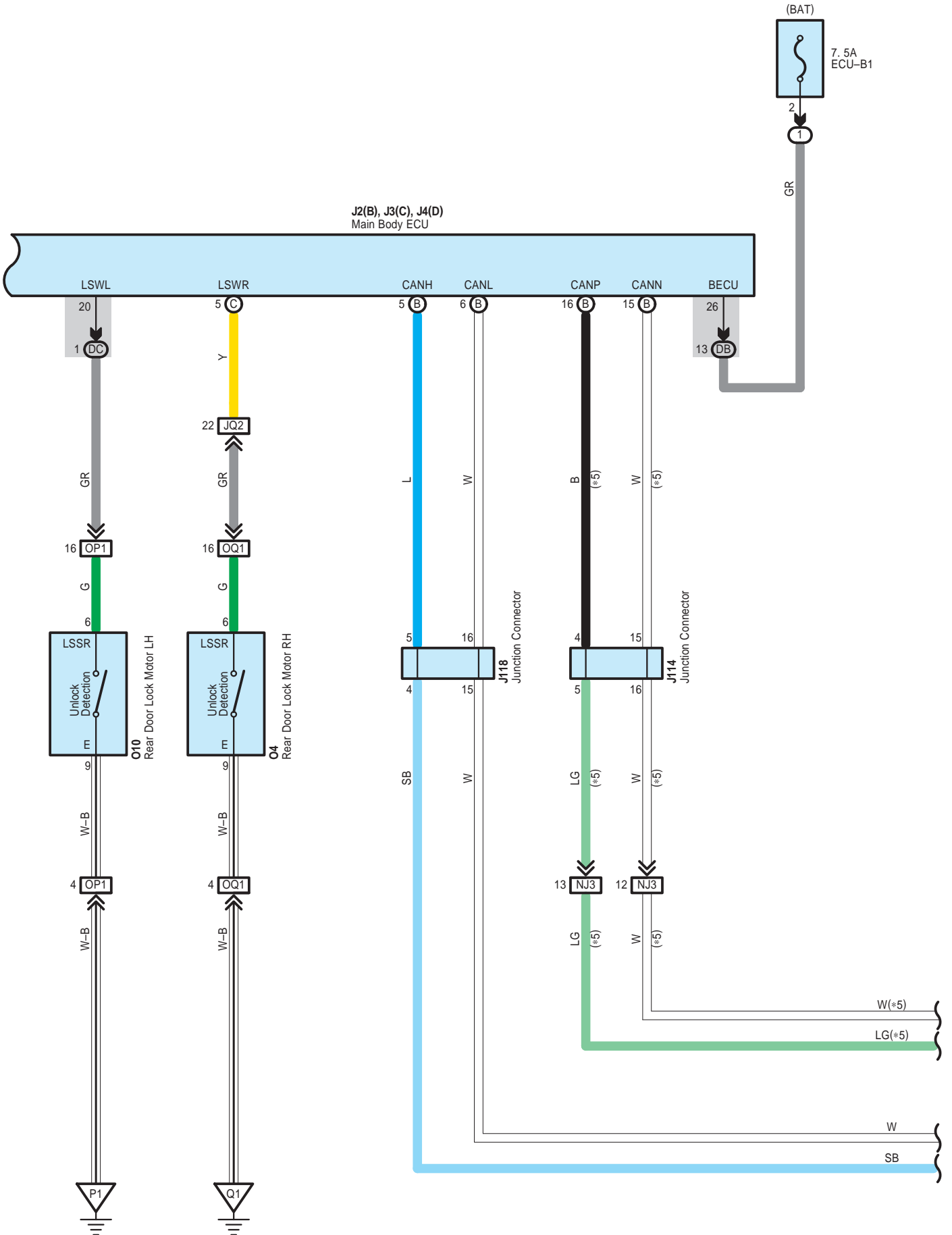



# Interior Light

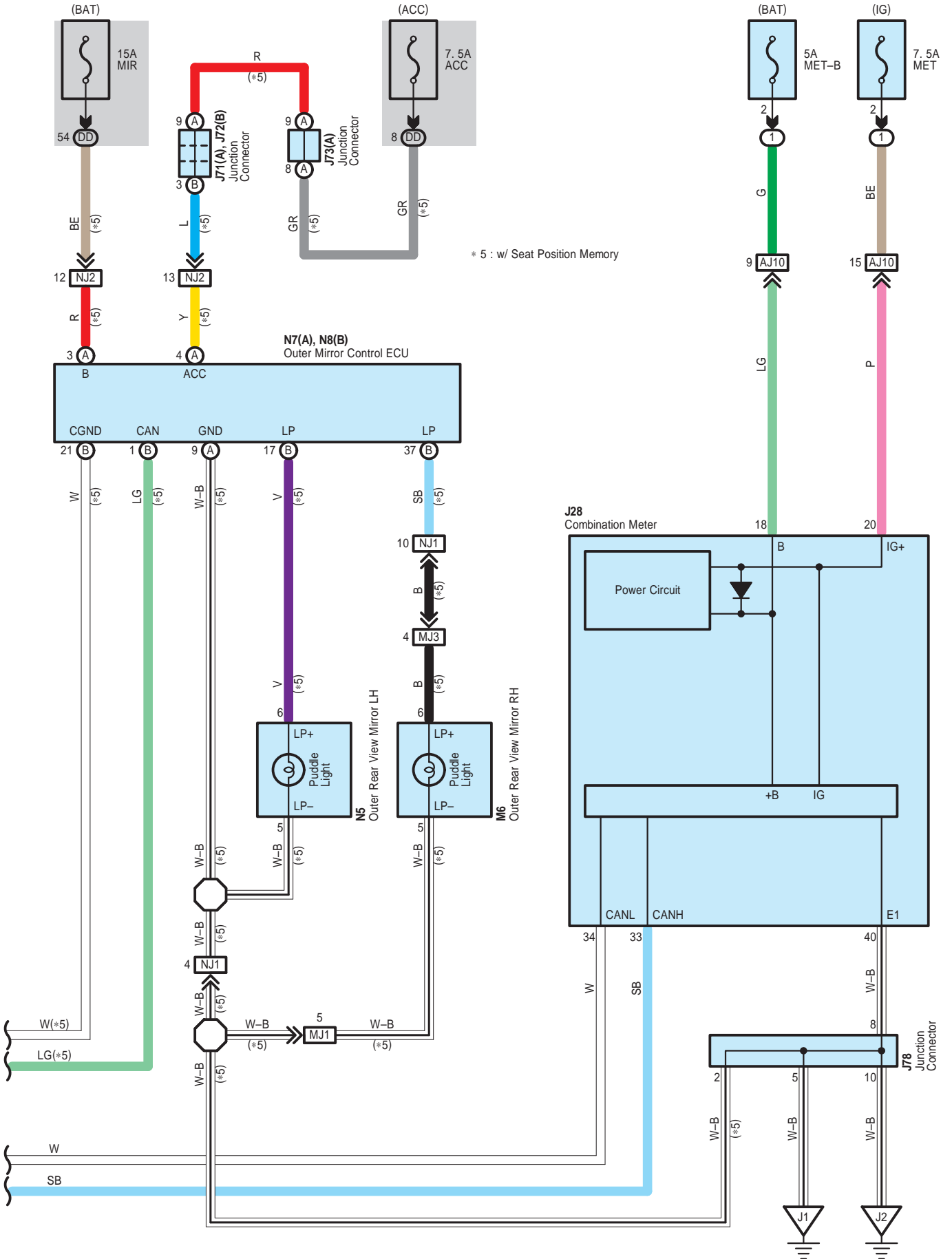

Interior Light

J 2  
White

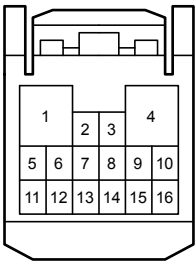

J 3  
White

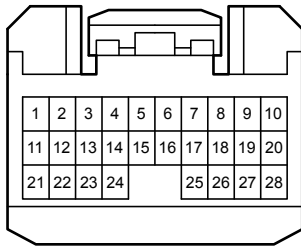

J 4  
White

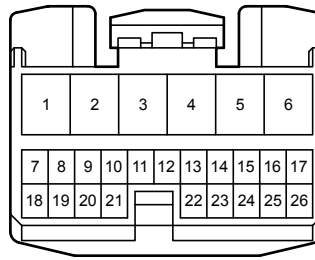

J 20  
Black

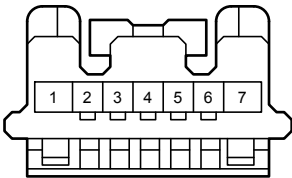

J 28  
White

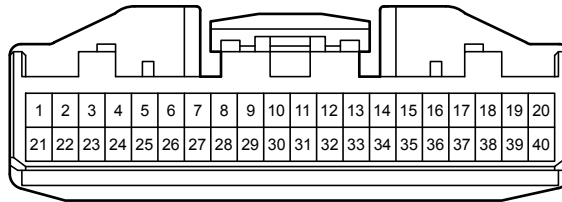

J 51  
Black

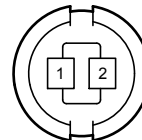

J 71  
Black

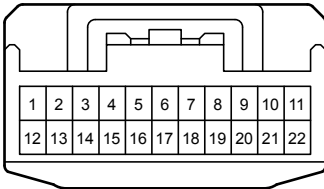

J 72  
Black

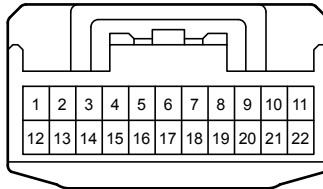

J 73  
Black

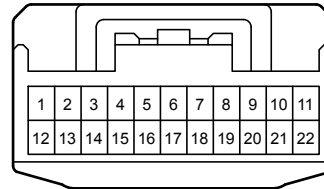

J 74  
Black

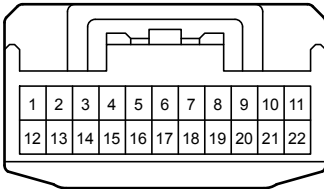

J 75  
White

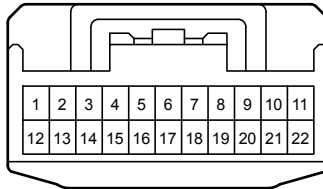

J 78  
White

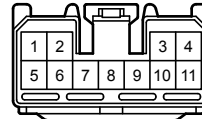

J 81  
White

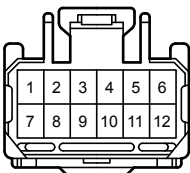

J 82  
White

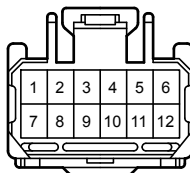

J 99  
Black

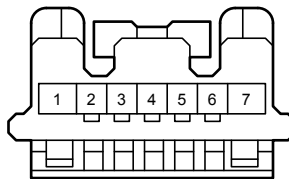

J114  
Gray

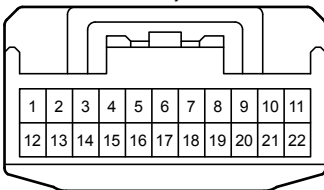

J118  
Gray

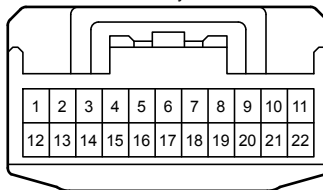

L 7  
Black

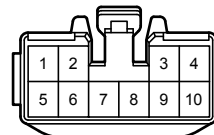



Interior Light

JL1  
White

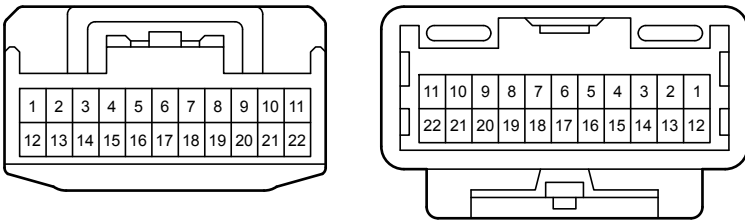

JQ2  
Gray

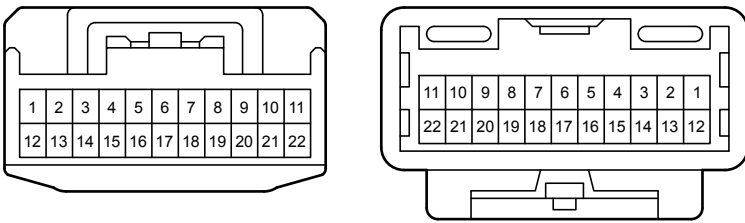

JW1  
White

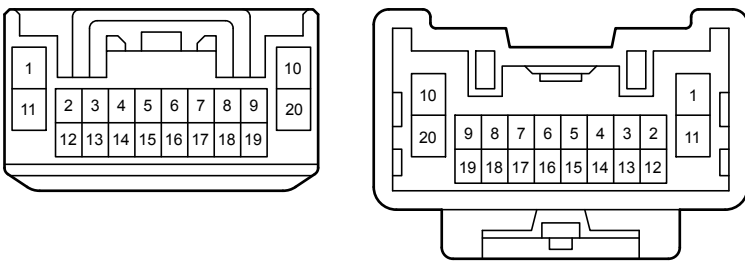

MJ1  
Blue

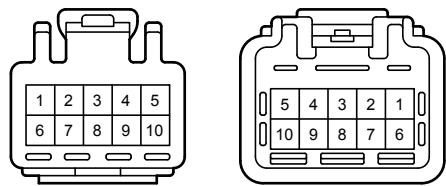

MJ3  
Blue

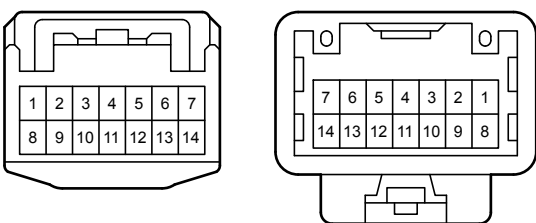

NJ1  
Blue

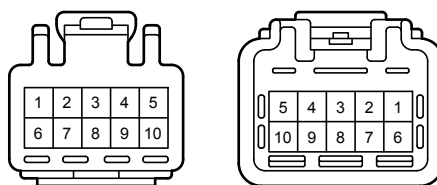

NJ2  
Blue

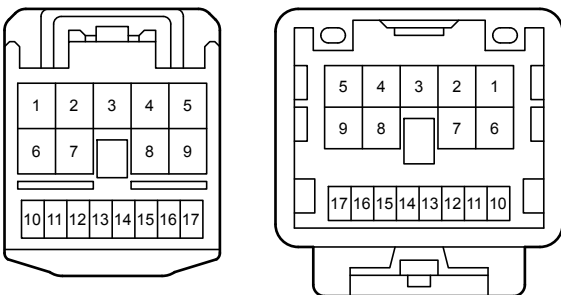

NJ3  
Blue

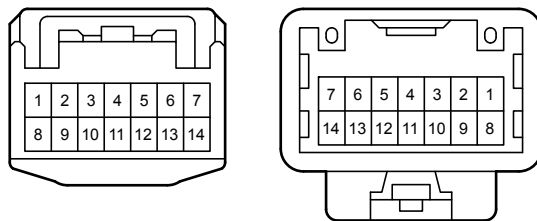

Interior Light

OP1  
White

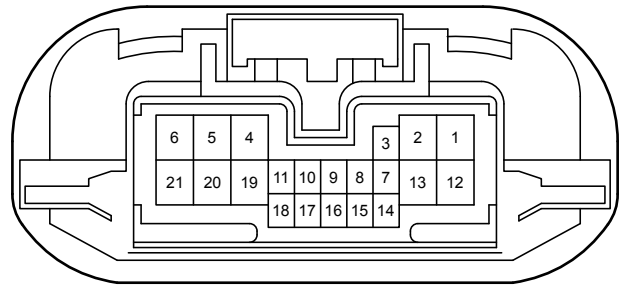
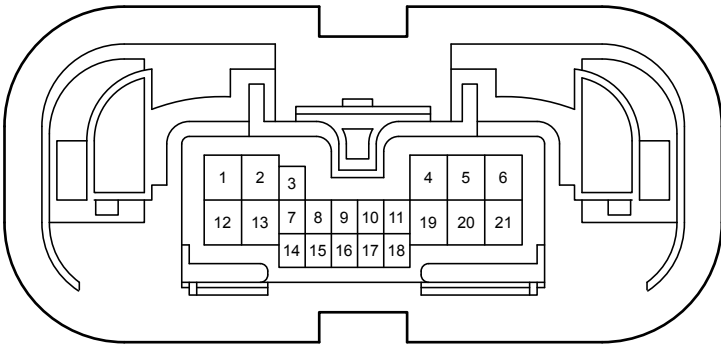

OQ1  
White

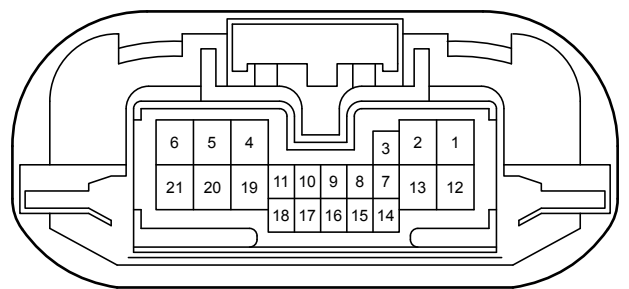
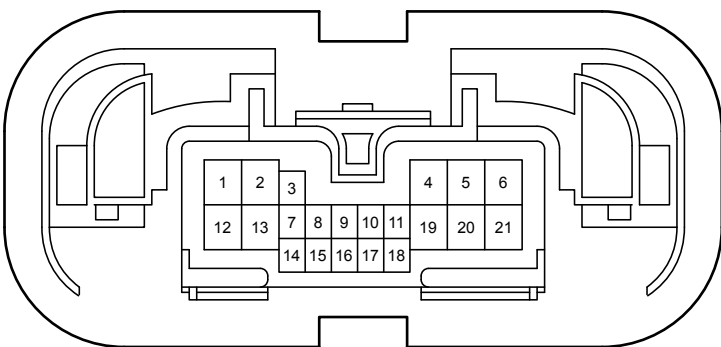

PJ1  
Black

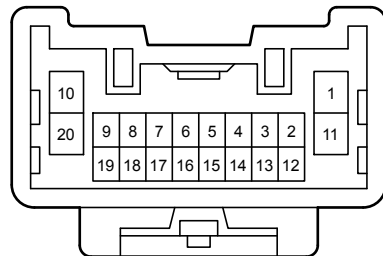
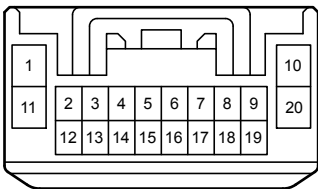



# Illumination

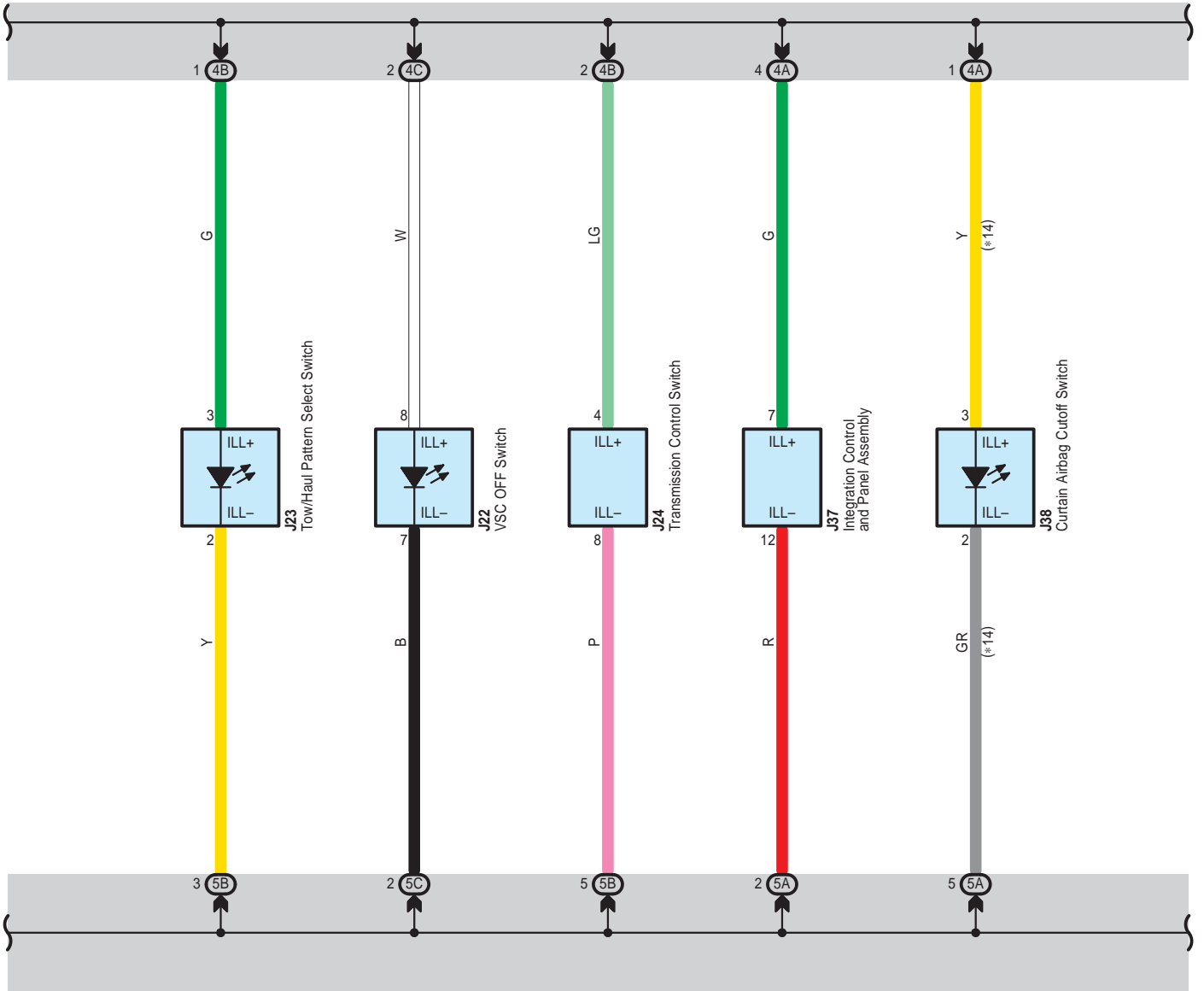

# Illumination

- \* 9 : w/ Climate Control Seat
- \*10 : w/o Climate Control Seat
- \*11 : w/ Headlight Leveling

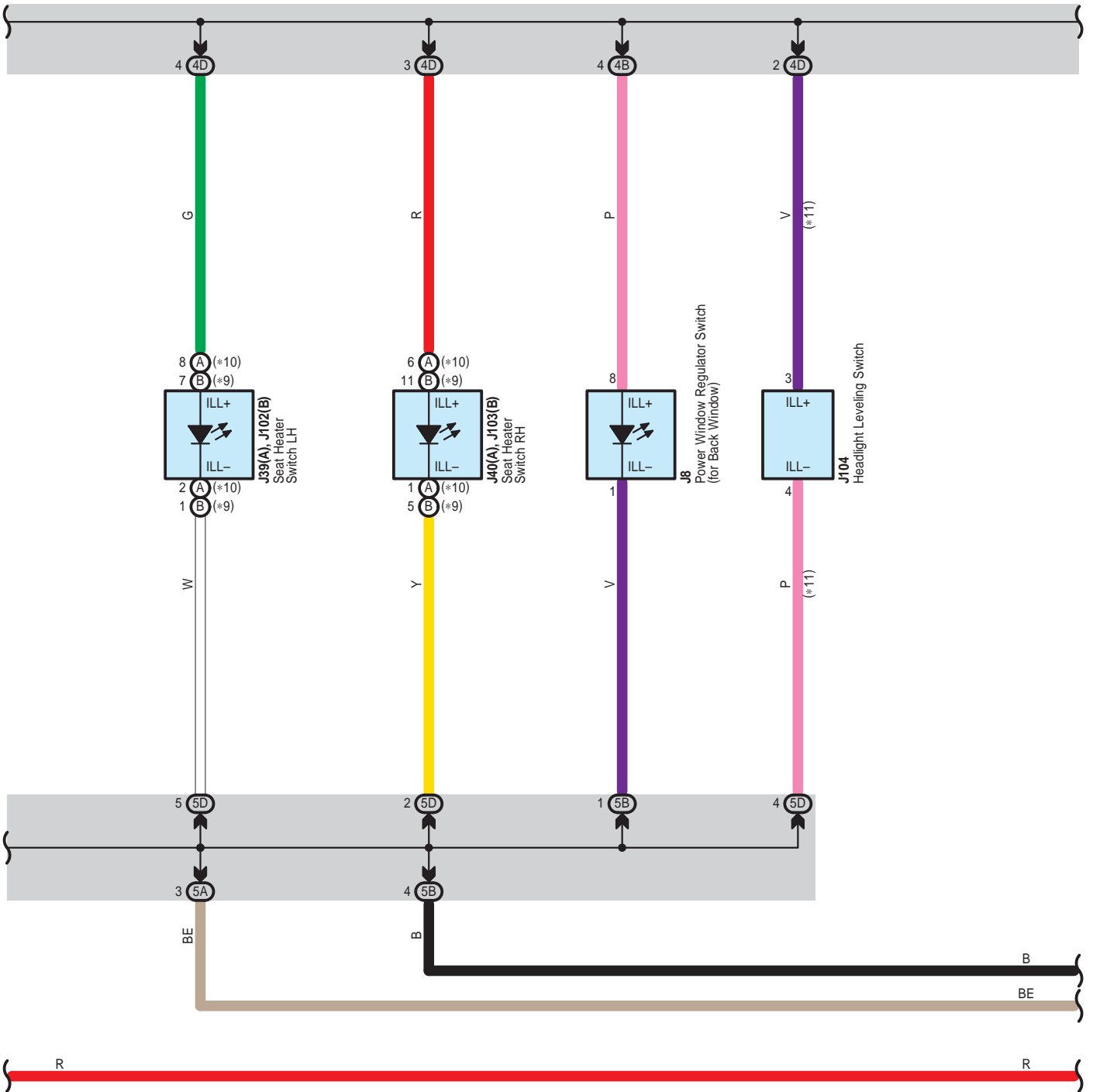



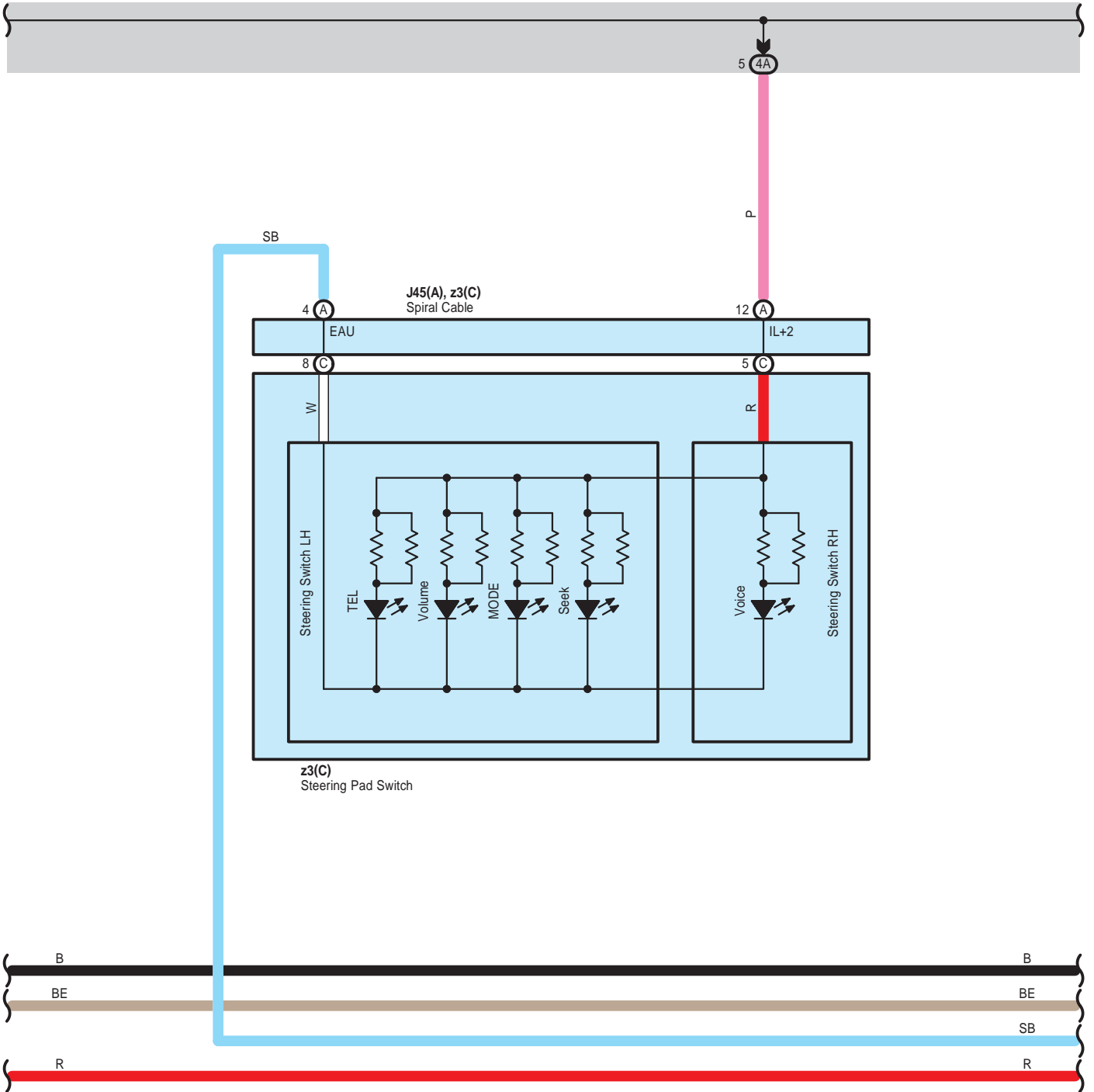

# Illumination

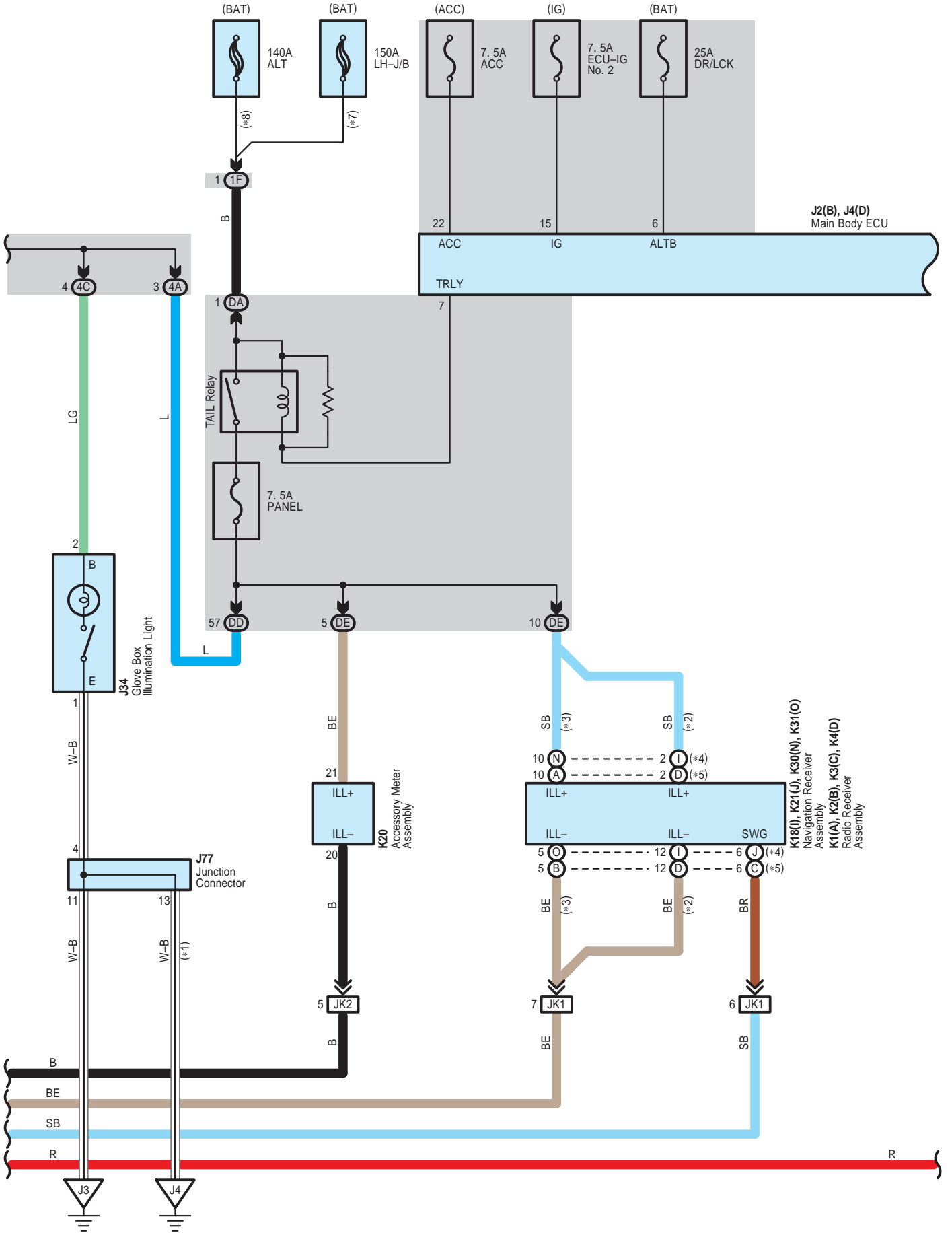

# Illumination

- \* 1 : w/ Seat Position Memory
- \* 2 : Separate Type Amplifier
- \* 3 : Built-in Type Amplifier
- \* 4 : w/ Navigation System
- \* 5 : w/o Navigation System
- \* 7 : 3UR-FE, 3UR-FBE, 1UR-FE
- \* 8 : 1GR-FE

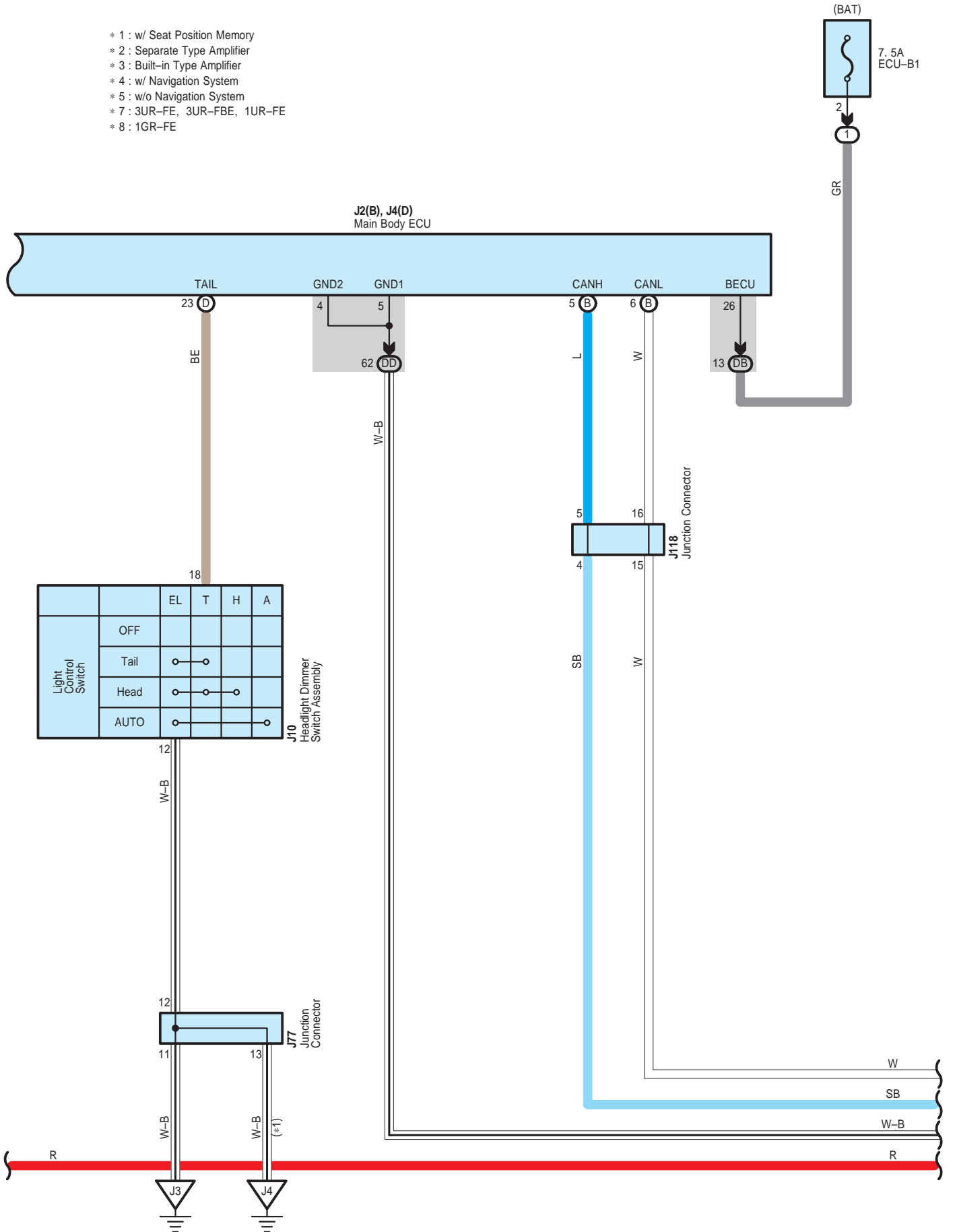

# Illumination

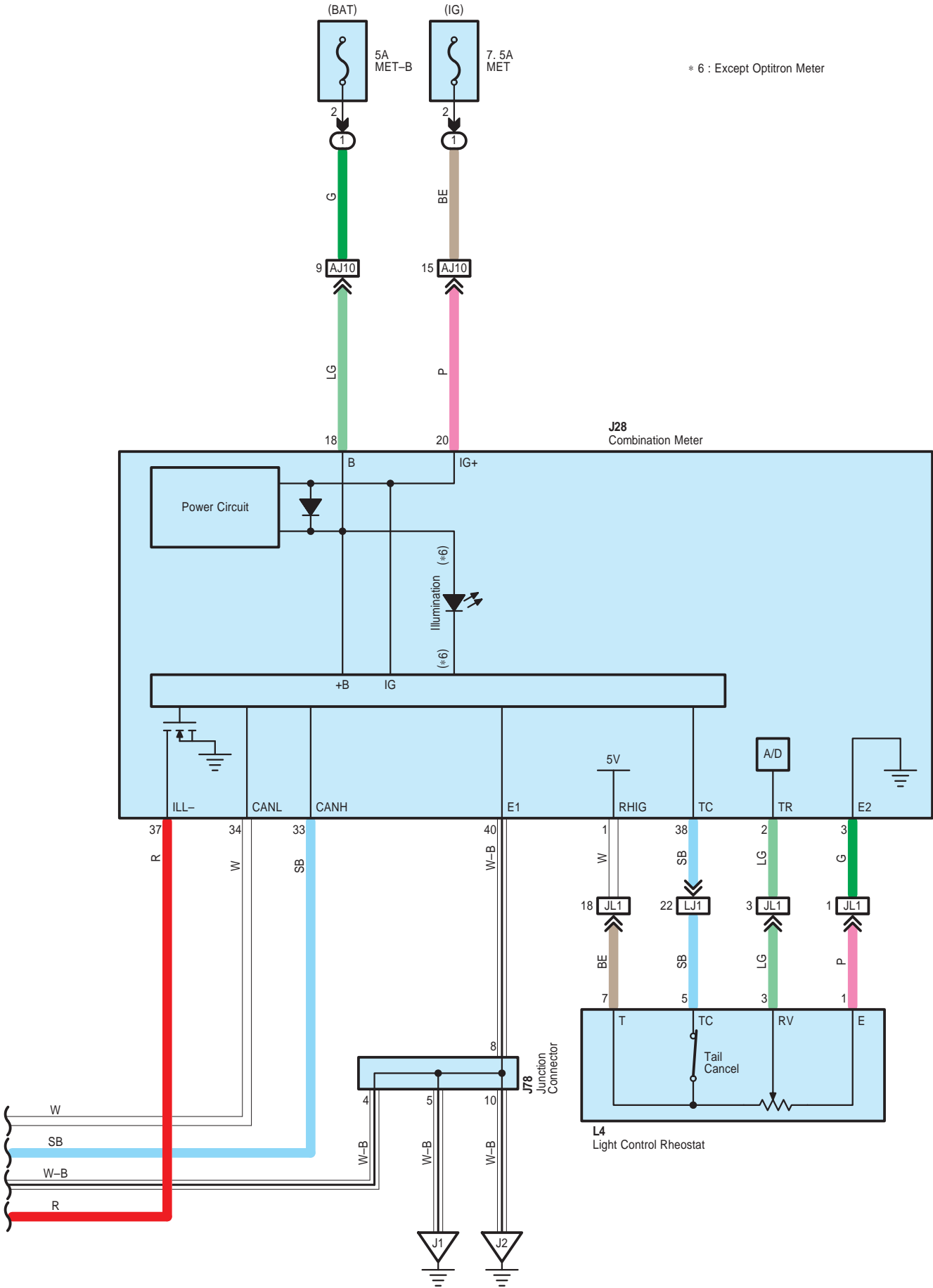

Illumination

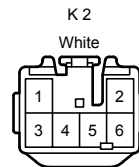
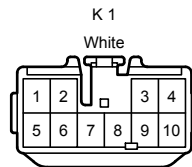
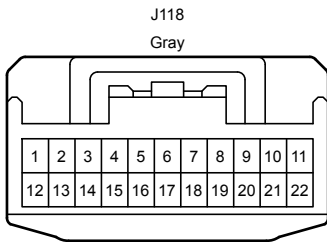
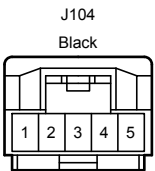
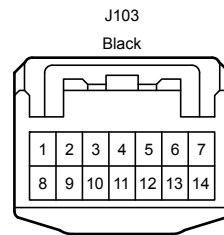
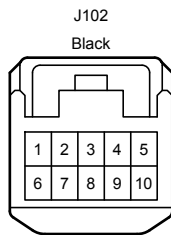
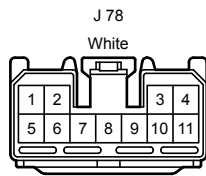
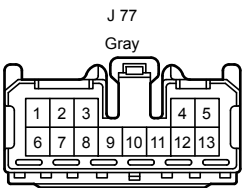
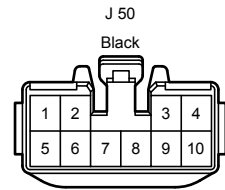
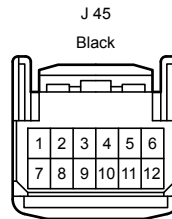
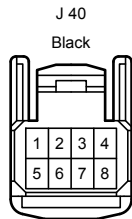
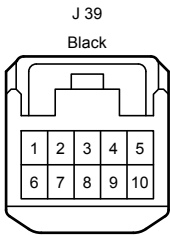
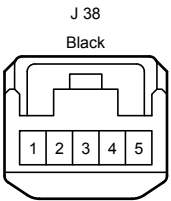
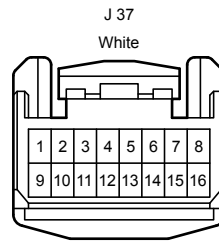
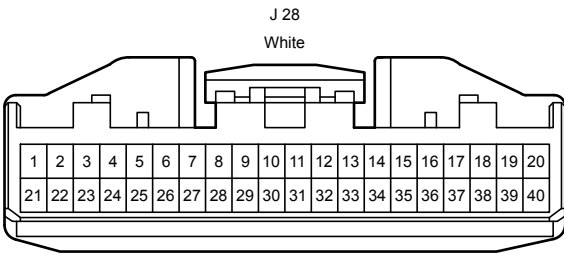
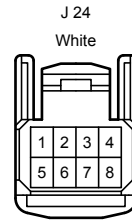
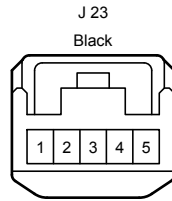
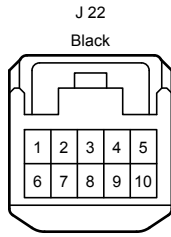
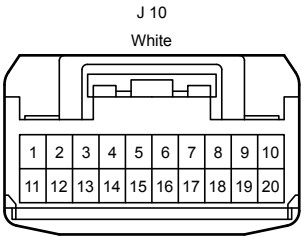
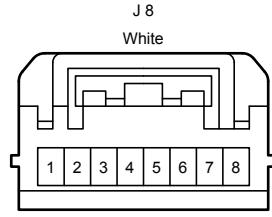
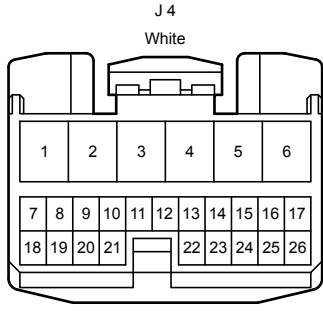
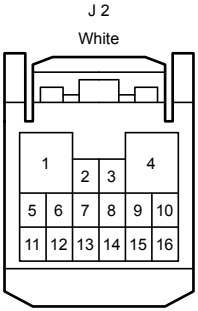

illumination

K 3  
White

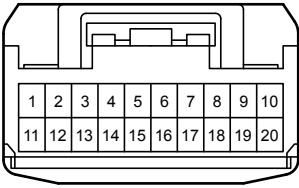

K 4  
White

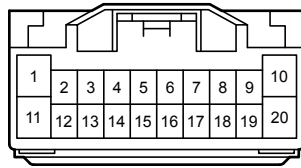

K 18  
White

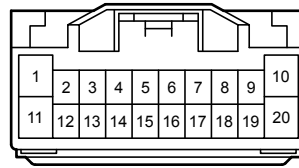

K 20  
White

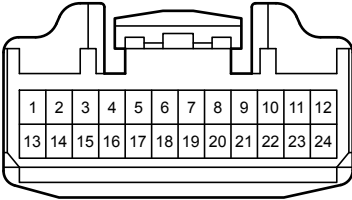

K 21  
White

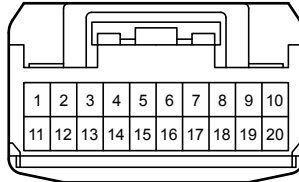

K 30  
White

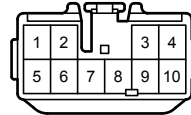

K 31  
White

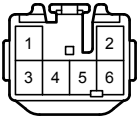

L 1  
Black

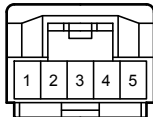

L 2  
Black

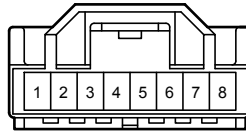

L 3  
Gray

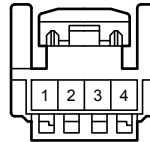

L 4  
White

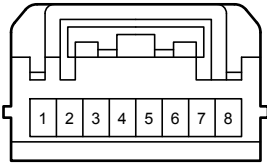

L 7  
Black

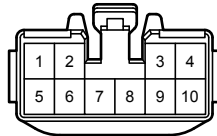

z 3  
Black

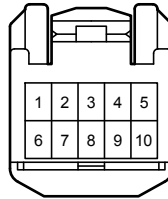

1F

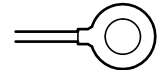

4A  
Black

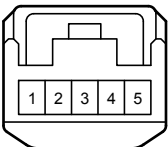

4B  
White

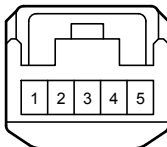

4C  
Blue

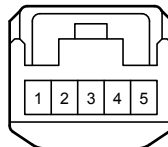

4D  
Gray

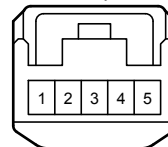

5A  
Black

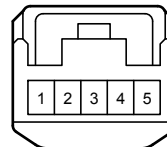

5B  
White

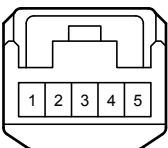

5C  
Blue

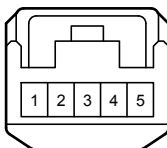

5D  
Gray

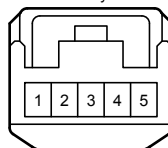

DA  
White

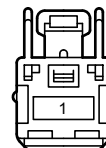

DB  
White

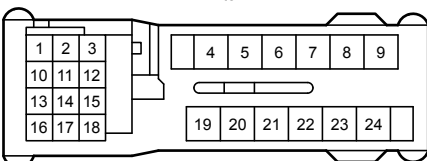

DD  
White

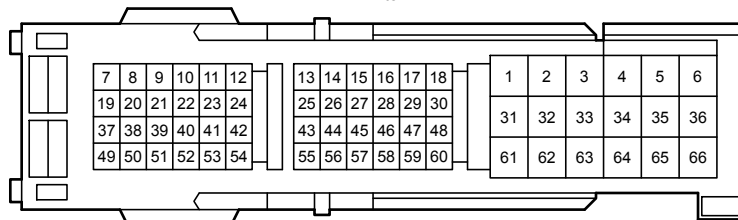

illumination

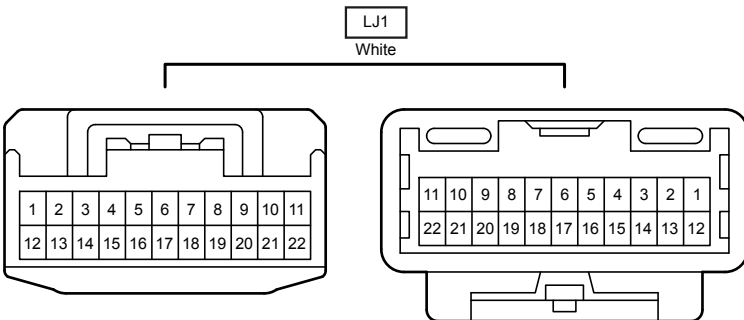
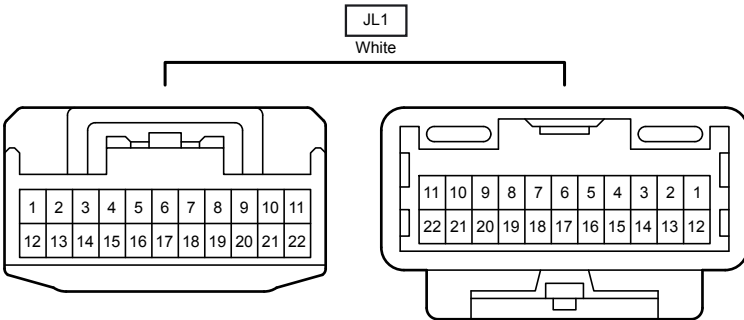
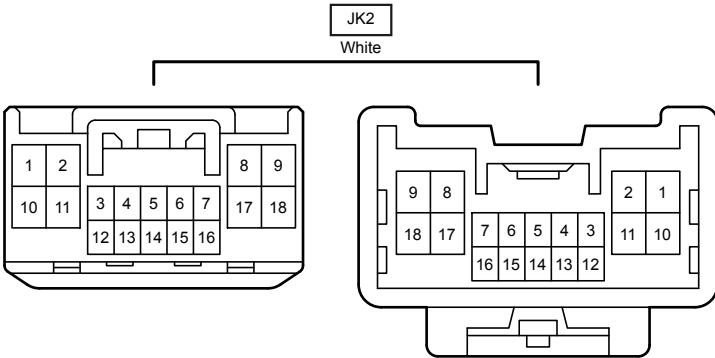
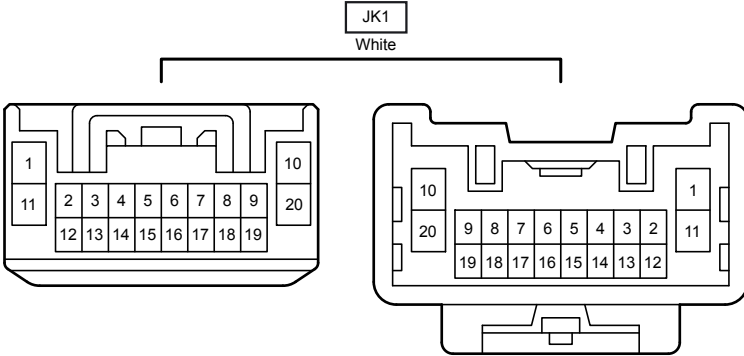
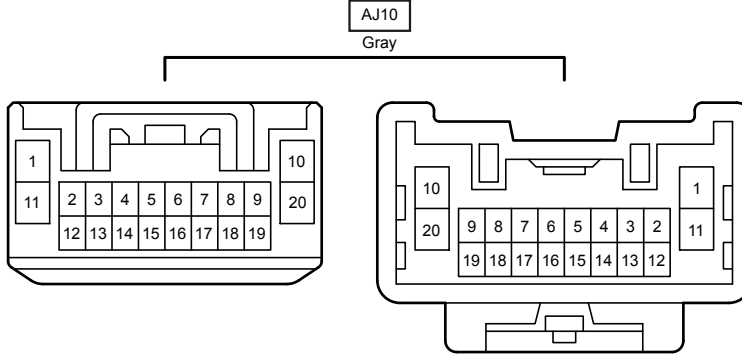
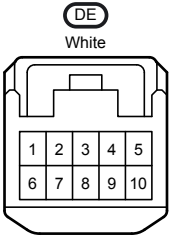

Ignition <1GR-FE>

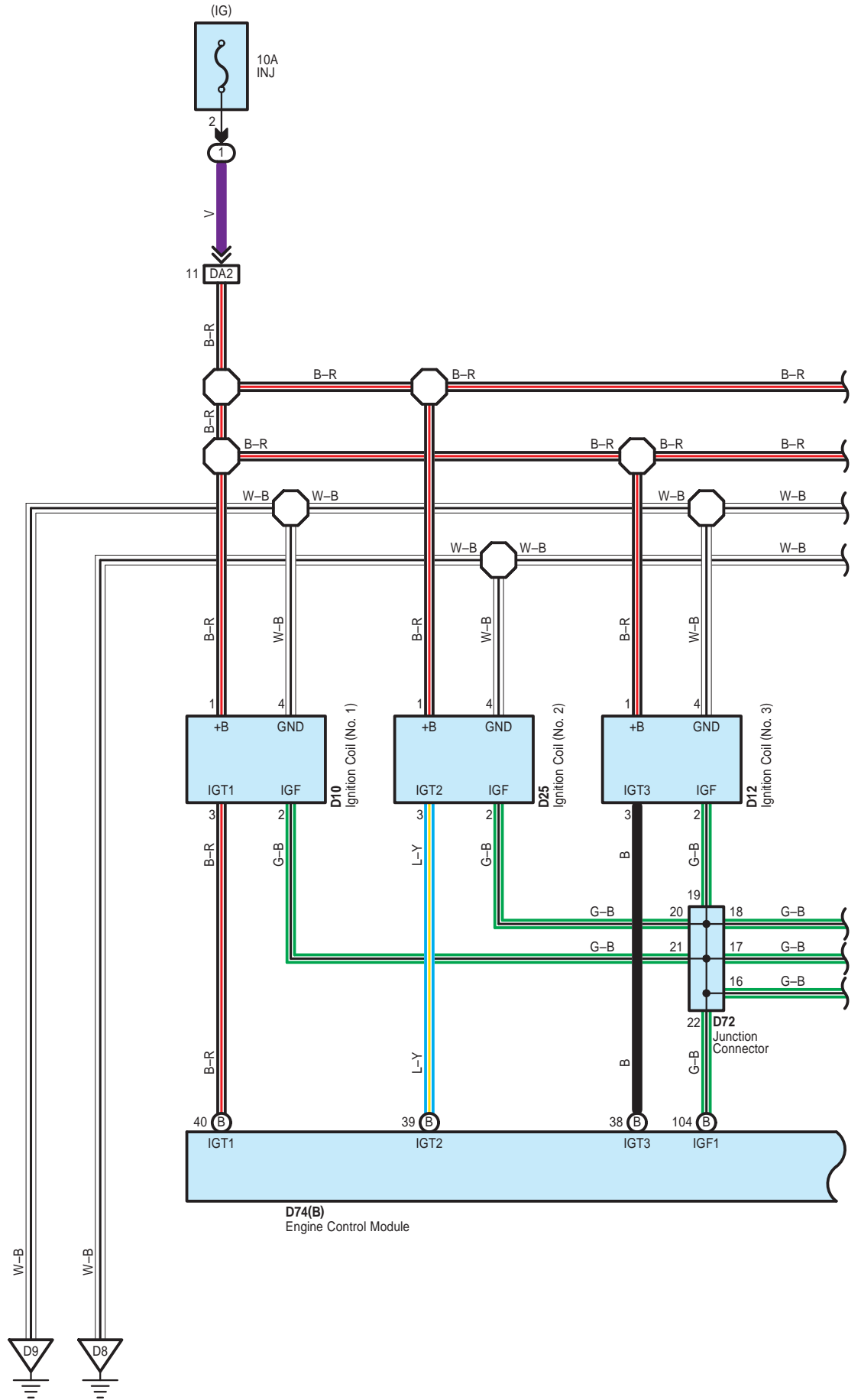



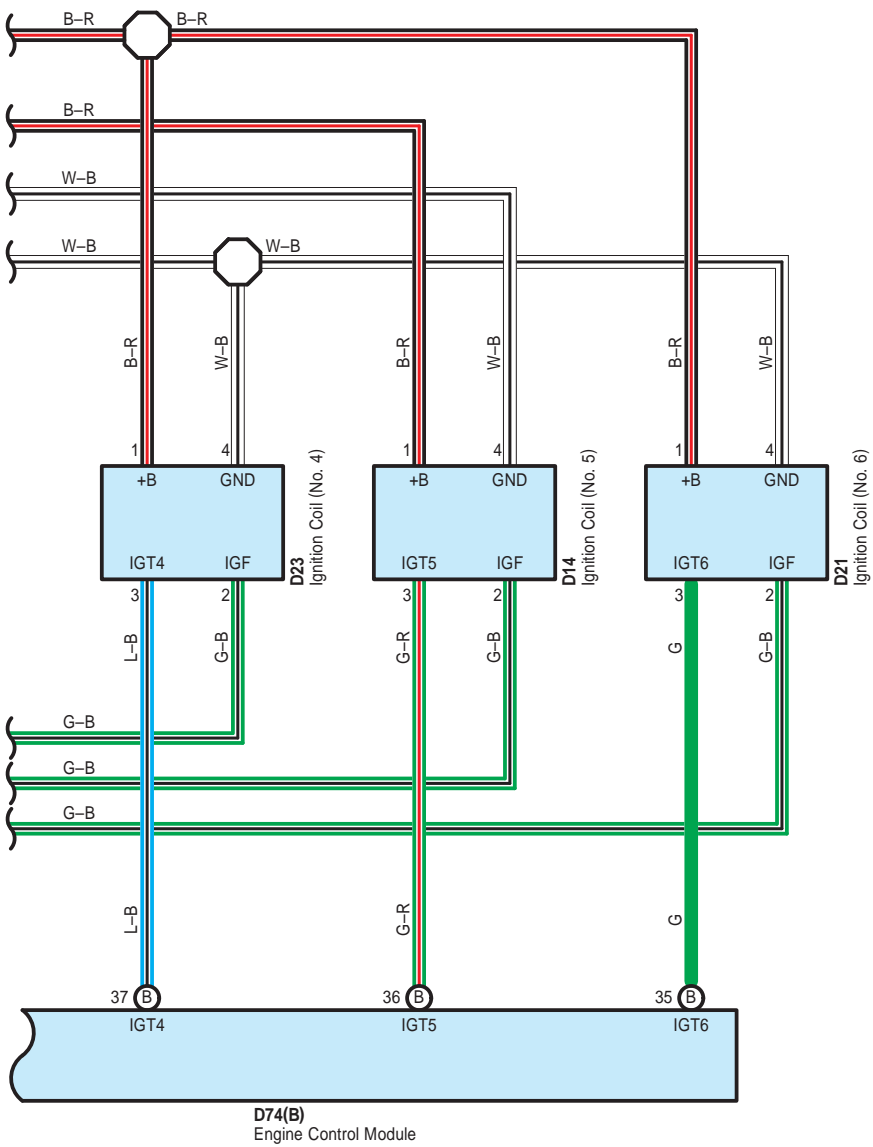

Ignition <1GR-FE>

D 10

Black

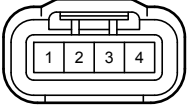

D 12

Black

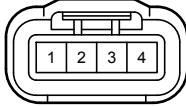

D 14

Black

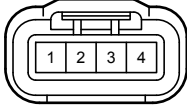

D 21

Black

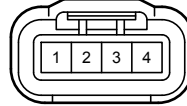

D 23

Black

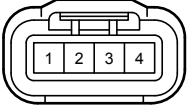

D 25

Black

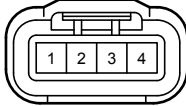

D 72

White

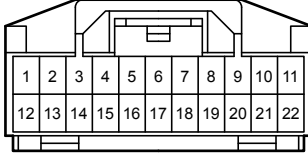

D 74

Black

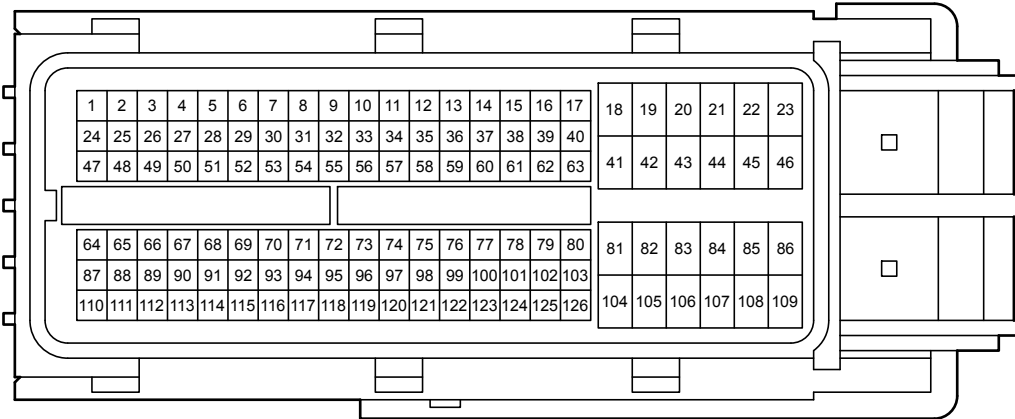

DA2

White

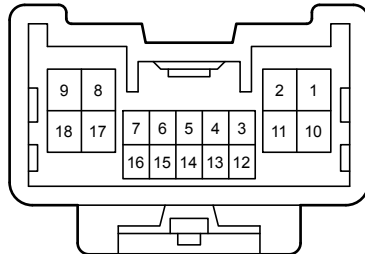
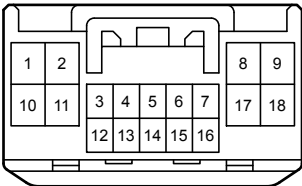

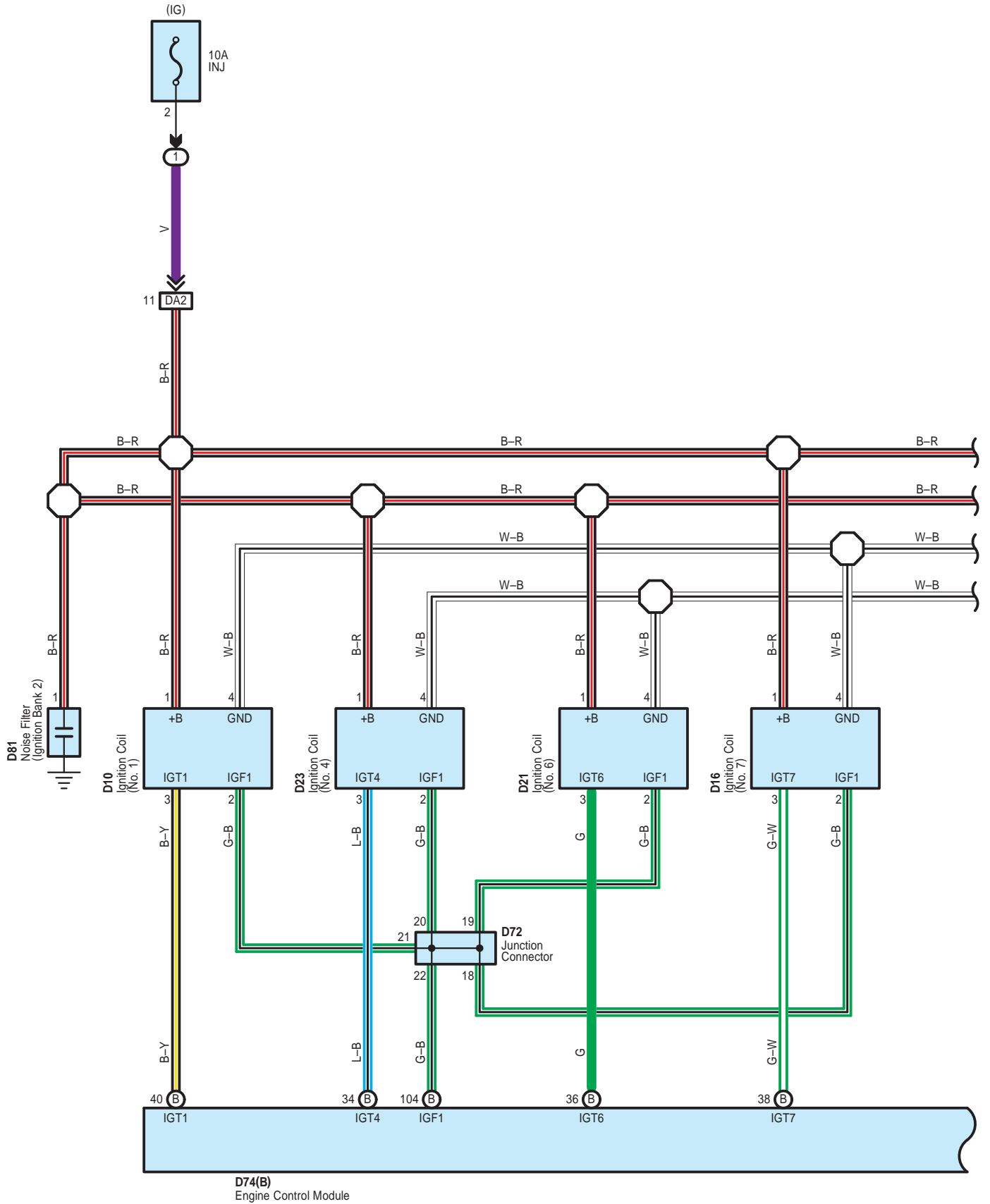

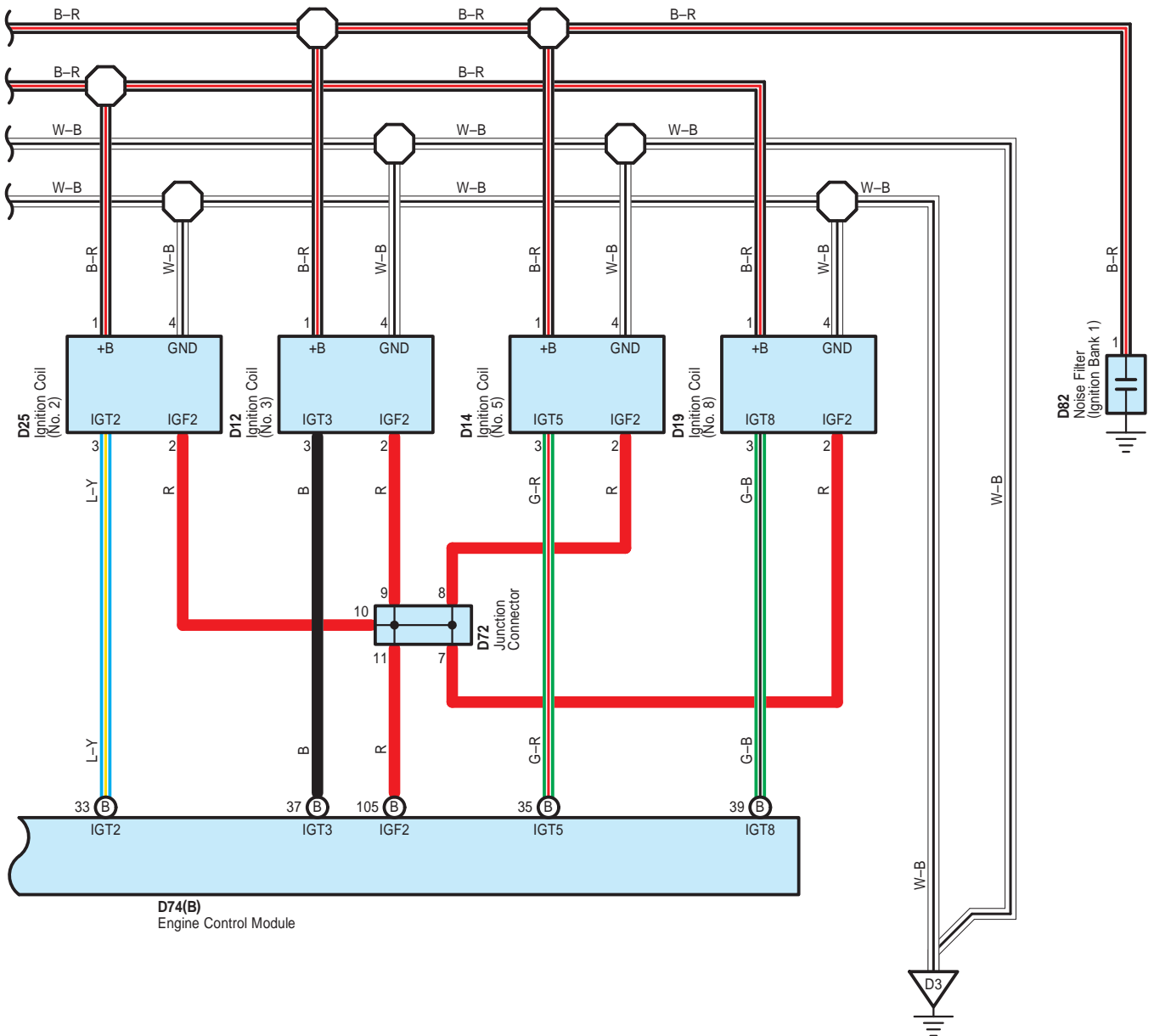

Ignition <1UR-FE>

D 10

Black

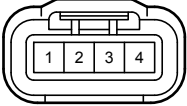

D 12

Black

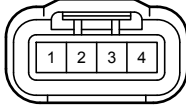

D 14

Black

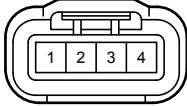

D 16

Black

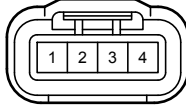

D 19

Black

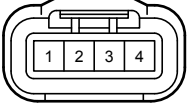

D 21

Black

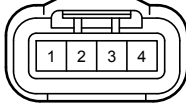

D 23

Black

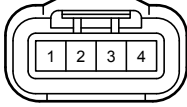

D 25

Black

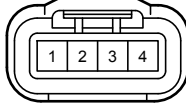

D 72

White

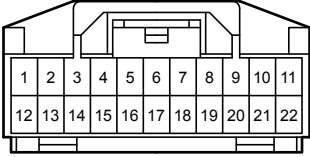

D 74

Black

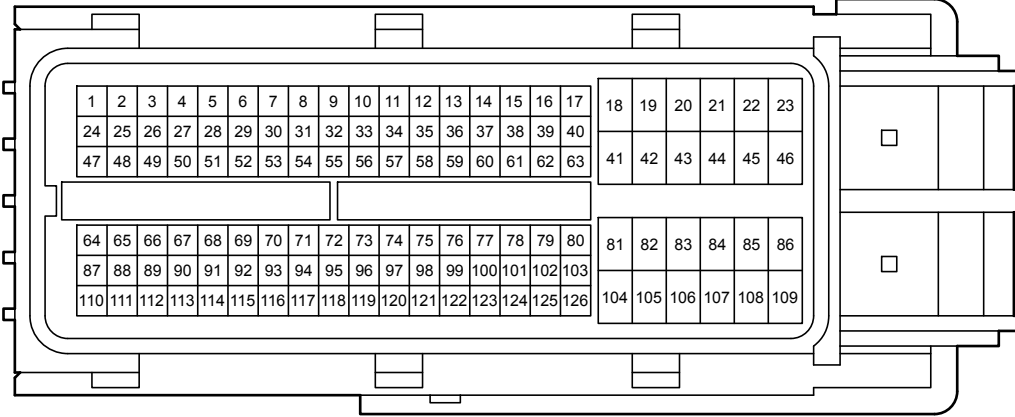

D 81

Gray

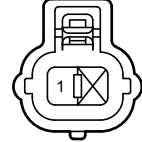

D 82

Gray

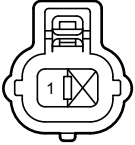

DA2

White

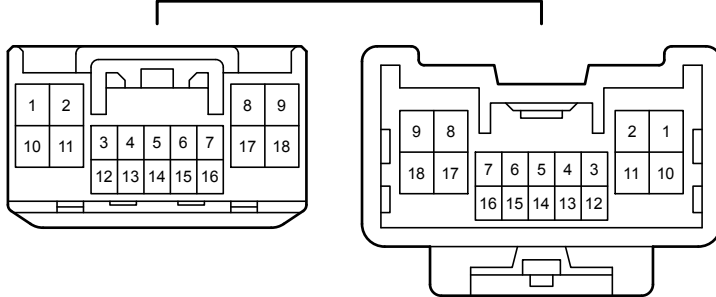

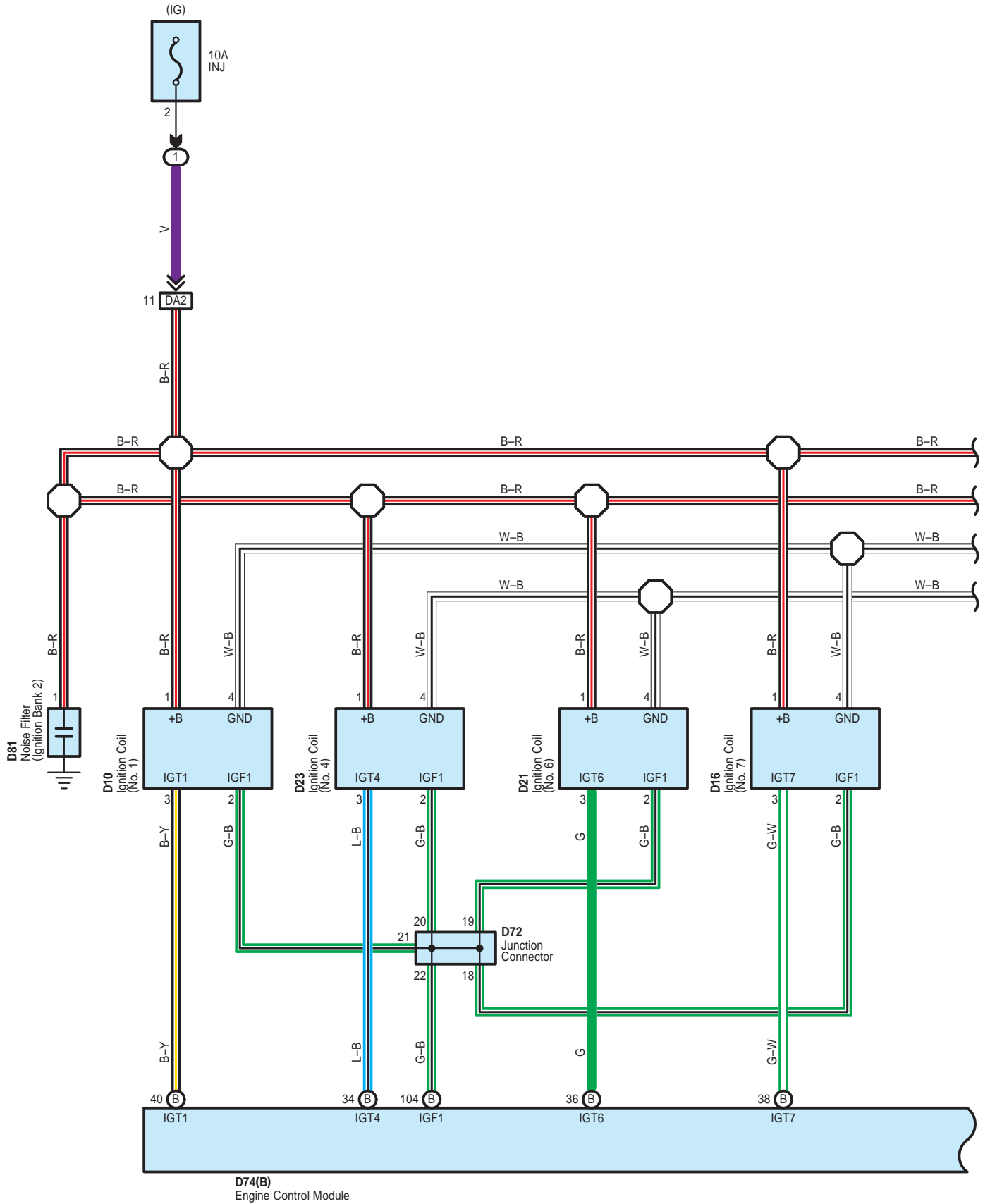

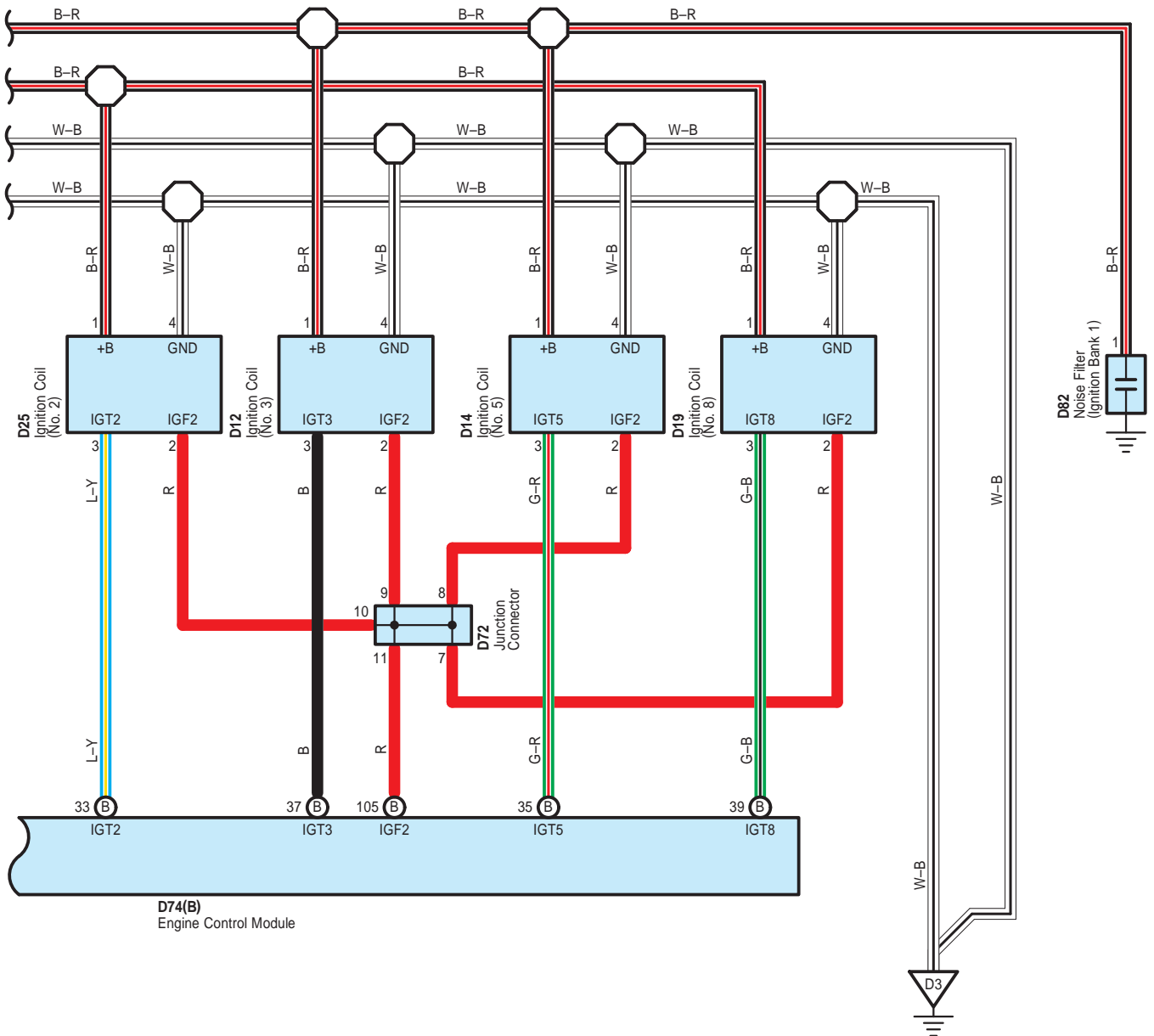





Key Reminder , Seat Belt Warning

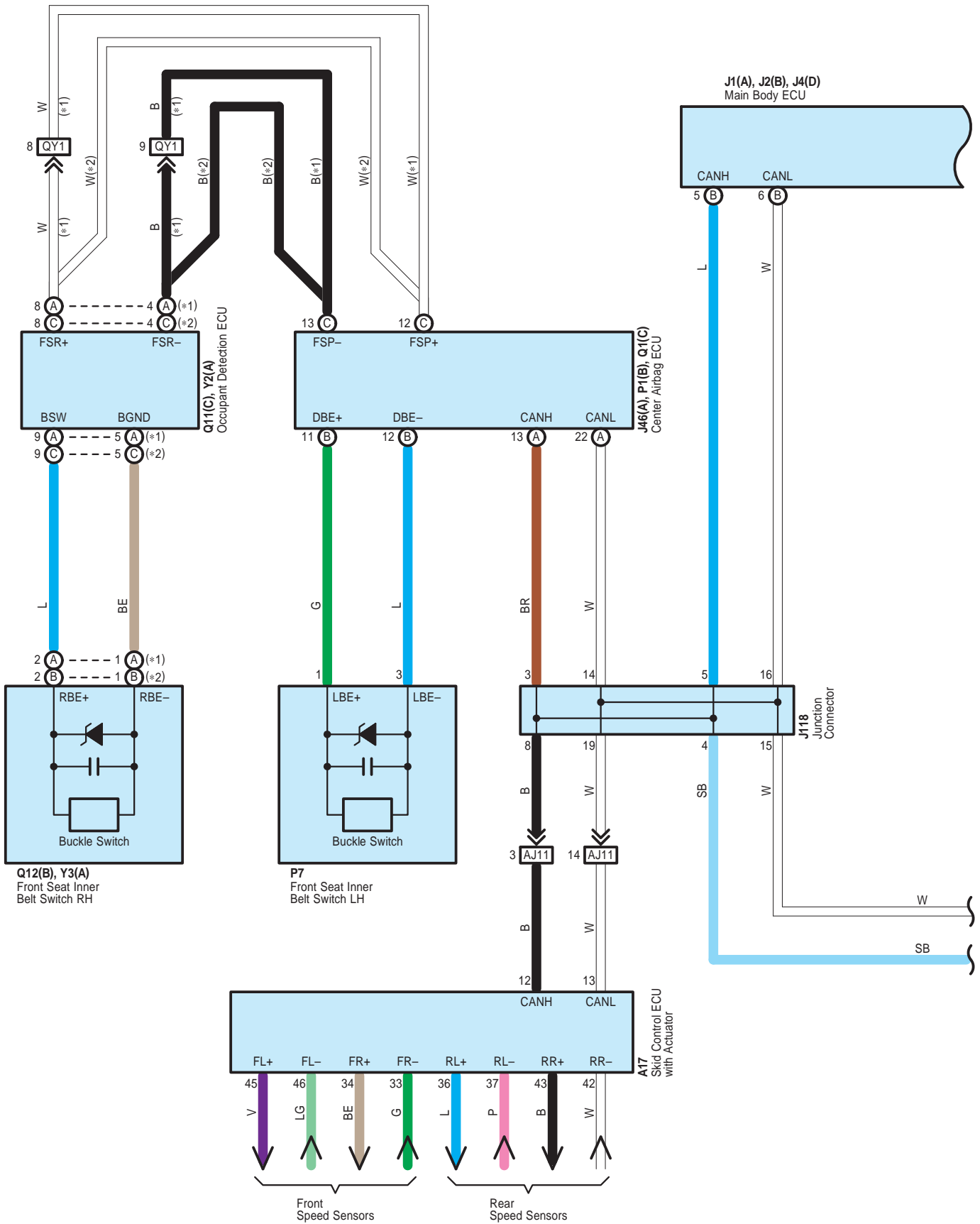

# Key Reminder , Seat Belt Warning

- \* 1 : w/ Power Seat
- \* 2 : w/o Power Seat

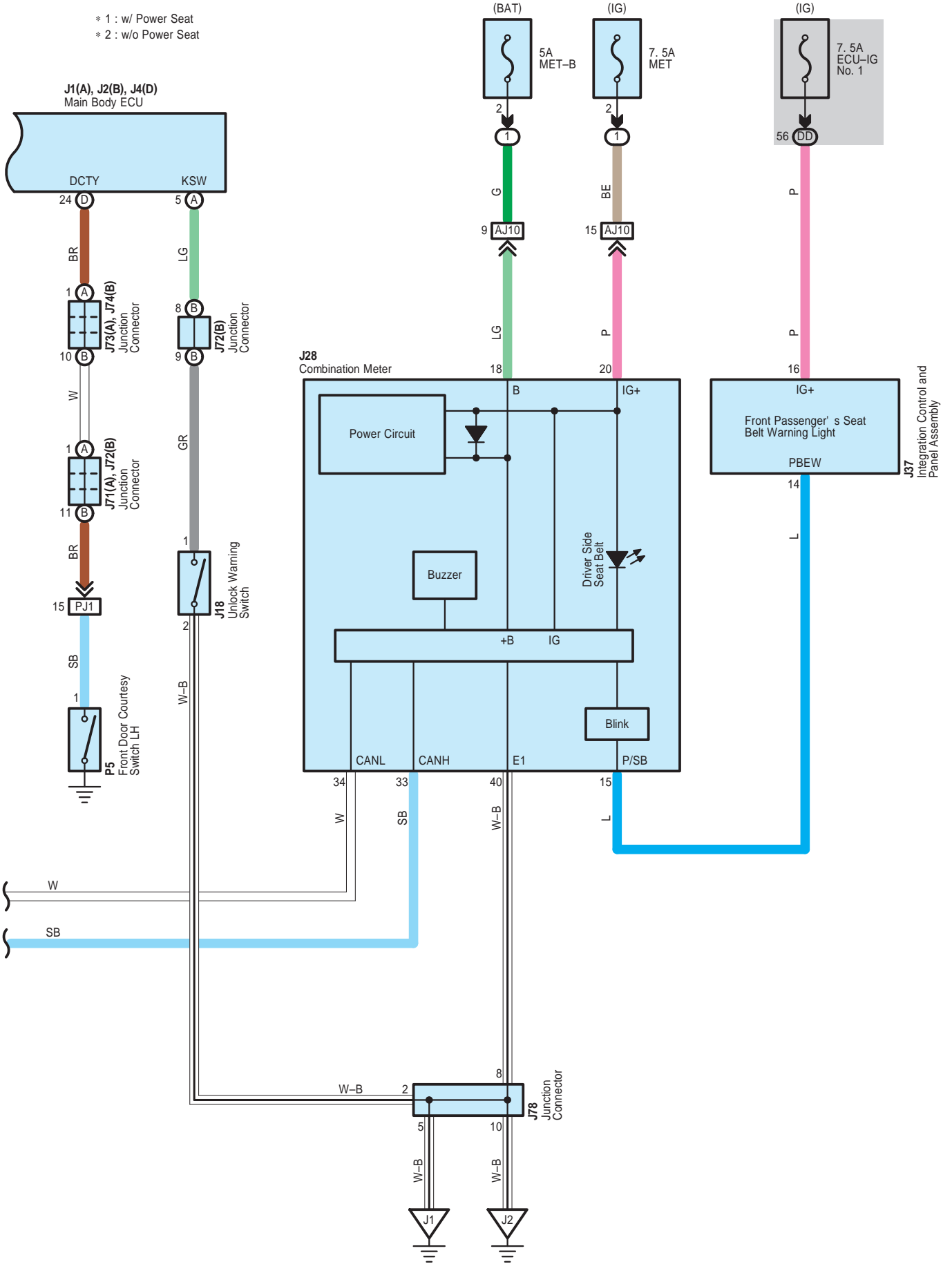

Key Reminder , Seat Belt Warning

A 17  
Black

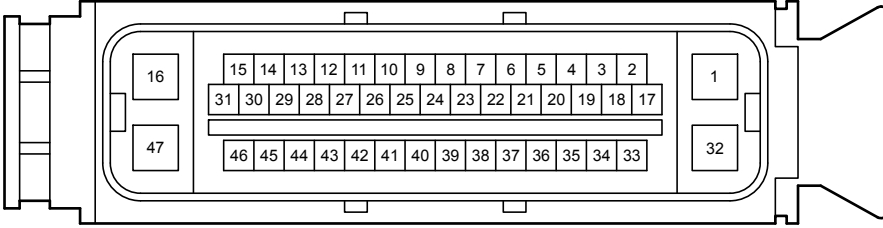

J 1  
White

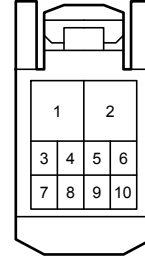

J 2  
White

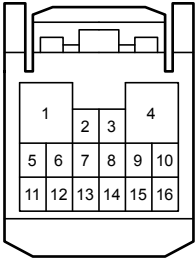

J 4  
White

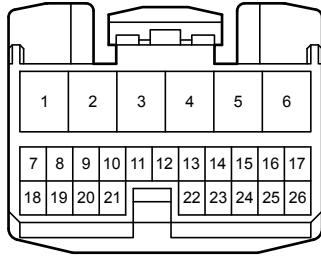

J 18  
White



J 28  
White

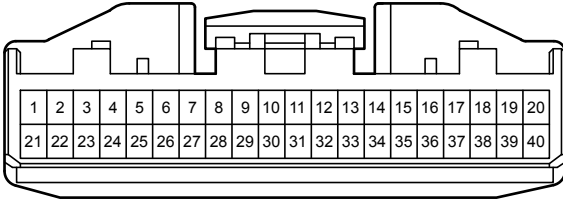

J 37  
White

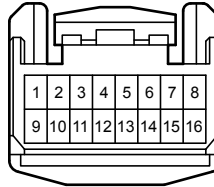

J 46  
Yellow

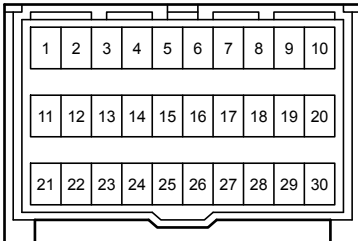

J 71  
Black

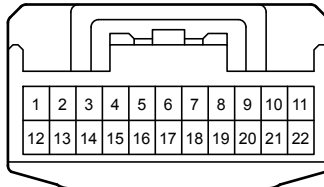

J 72  
Black

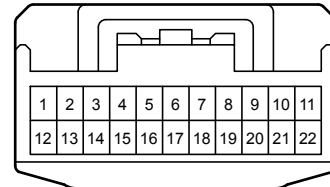

J 73  
Black

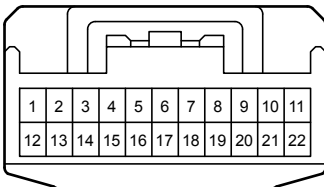

J 74  
Black

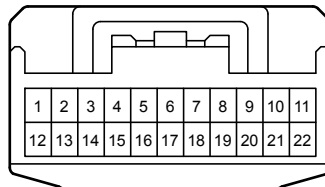

J 78  
White



Key Reminder , Seat Belt Warning

J118  
Gray

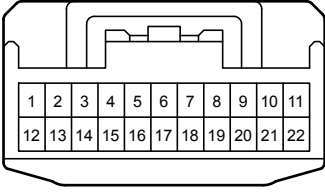

P 1  
Yellow

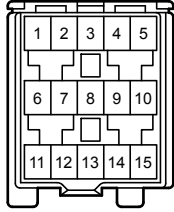

P 5  
White



P 7  
White



Q 1  
Yellow

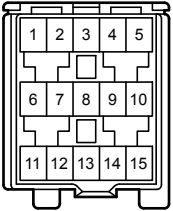

Q 11  
Black

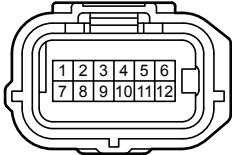

Q 12  
Gray

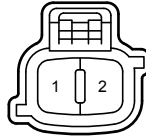

Y 2  
Black

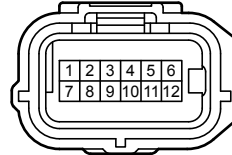

Y 3  
Gray

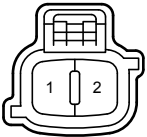

DD  
White

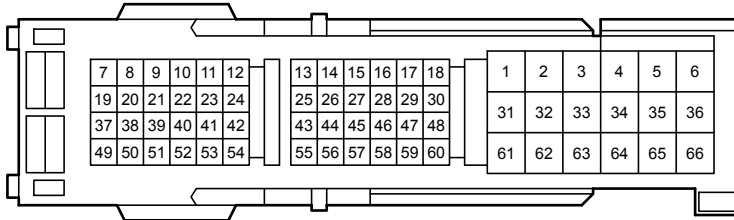

AJ10  
Gray

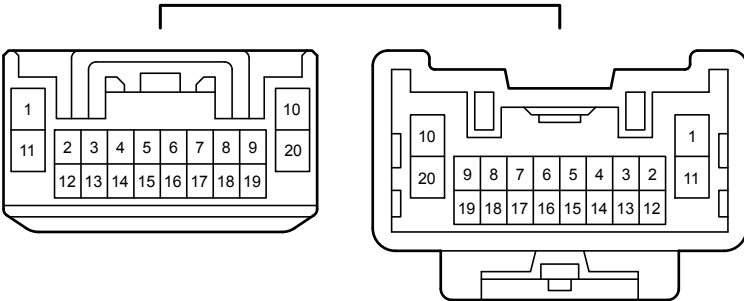

AJ11  
Gray

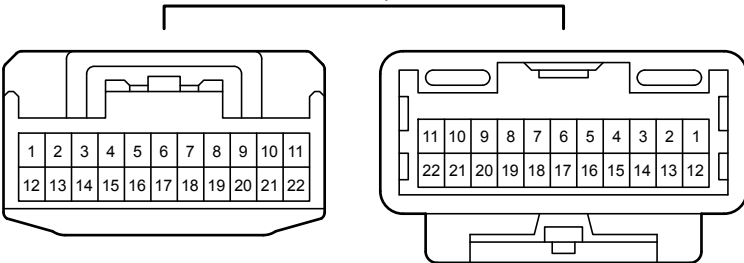

PJ1  
Black

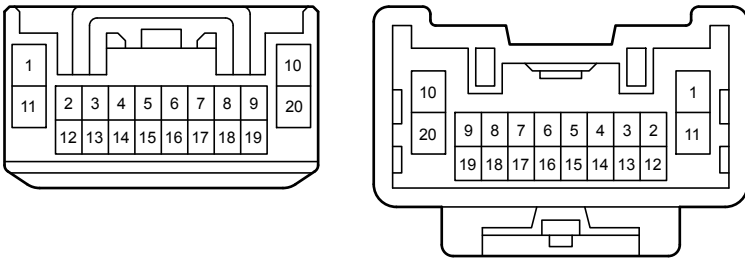

QY1  
White

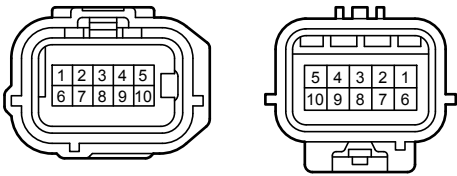



# Mirror Heater

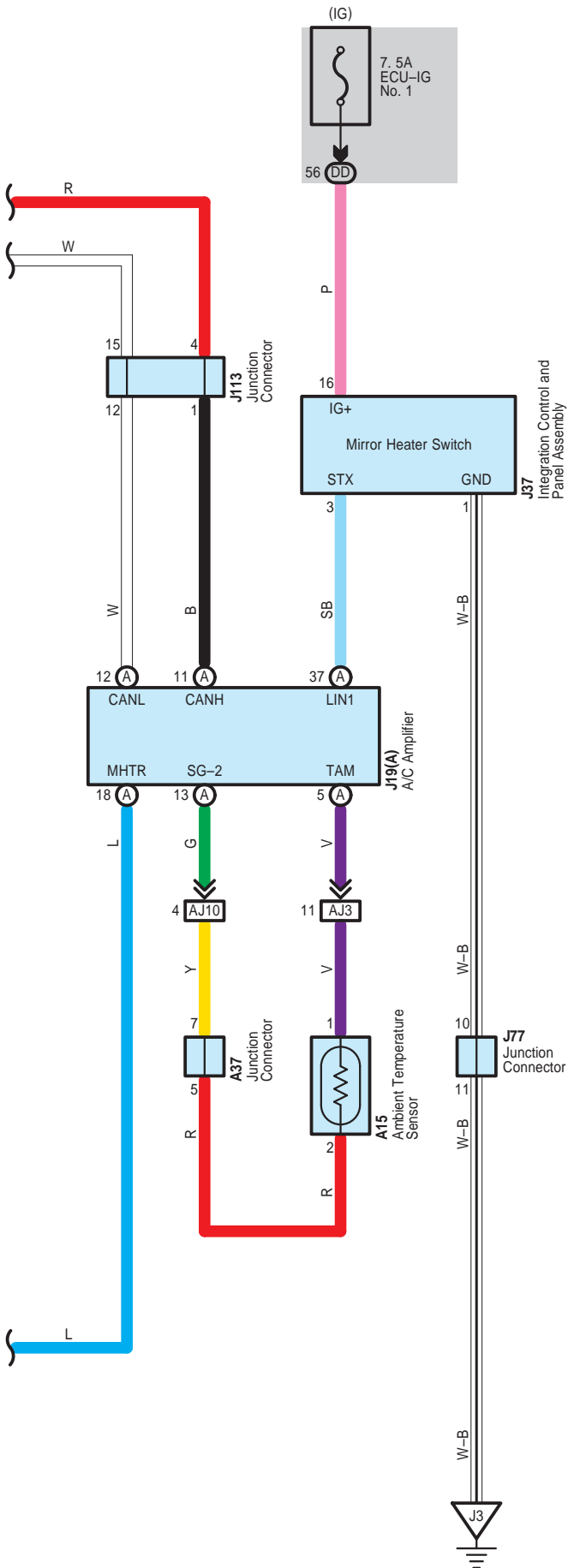

Mirror Heater

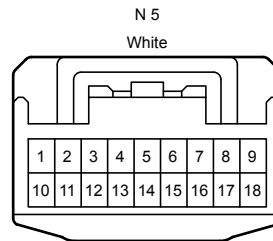
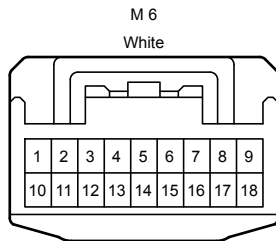
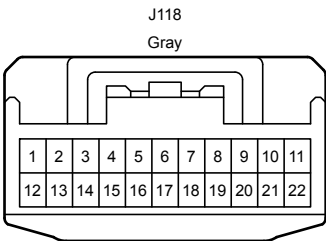
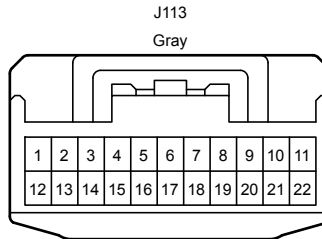
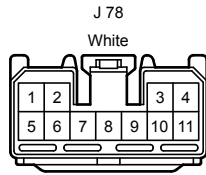
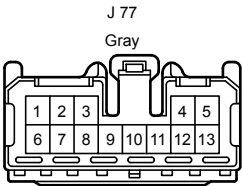
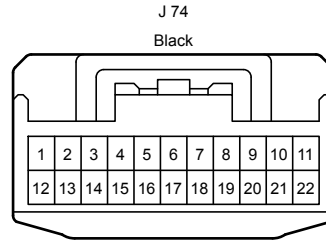
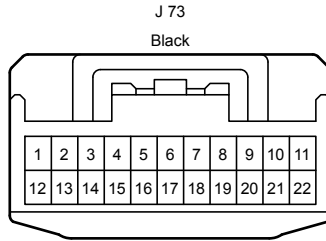
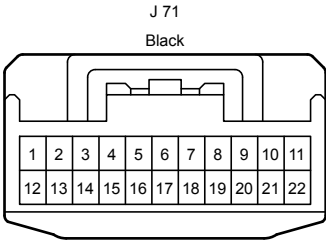
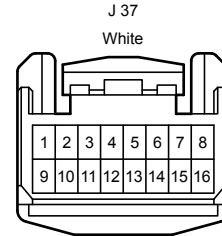
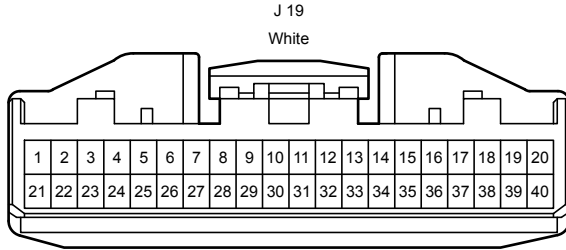
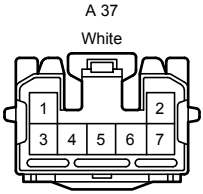
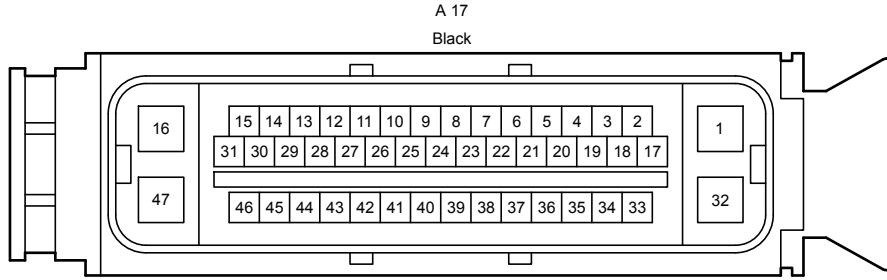

DD  
White

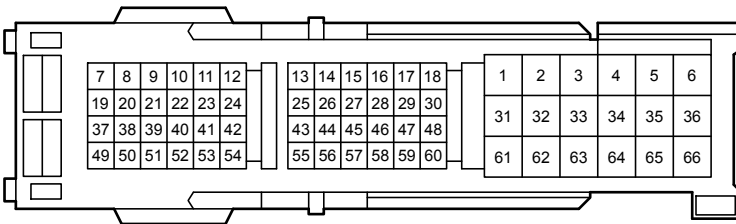



Mirror Heater

AJ3  
White

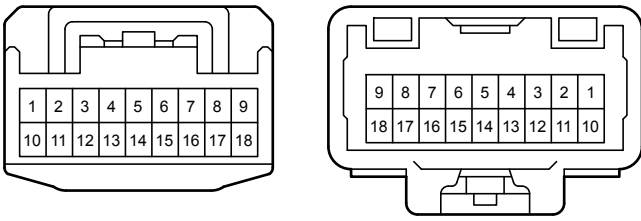

AJ10  
Gray

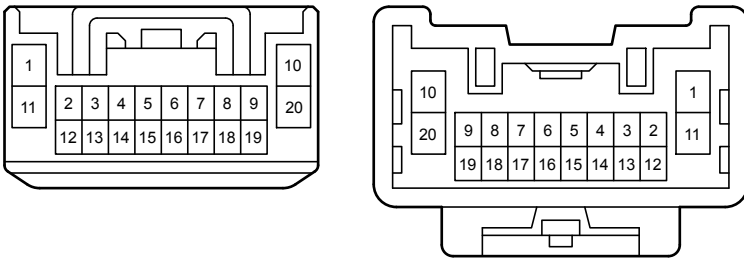

AJ11  
Gray

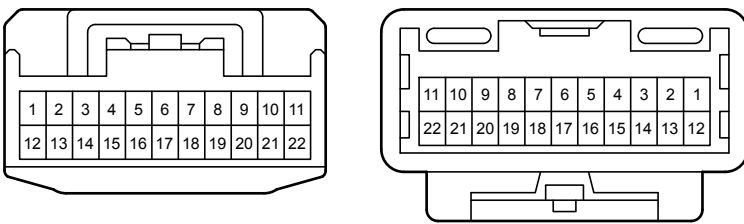

MJ1  
Blue

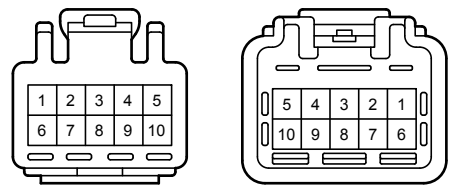

MJ3  
Blue

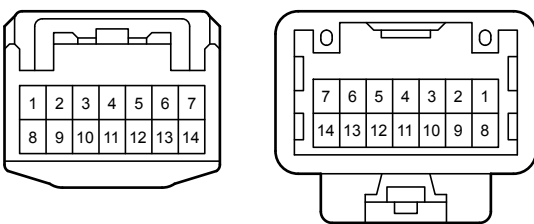

NJ1  
Blue

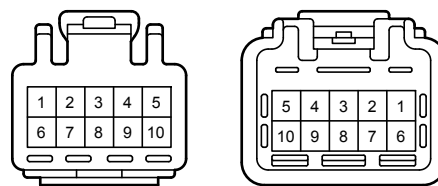

NJ2  
Blue

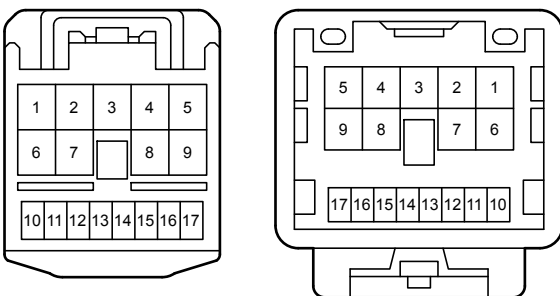

Multi Mode 4WD

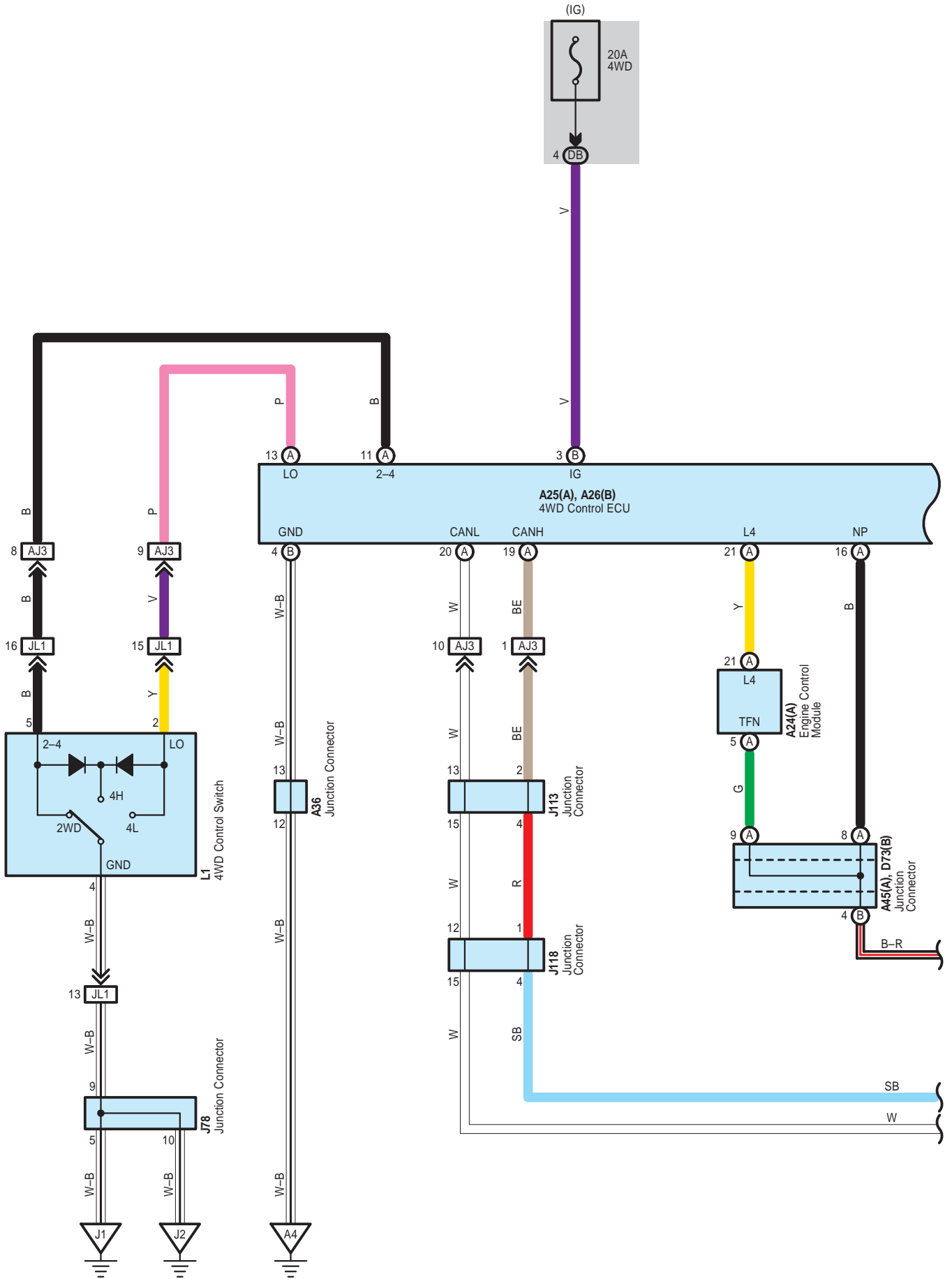

Multi Mode 4WD

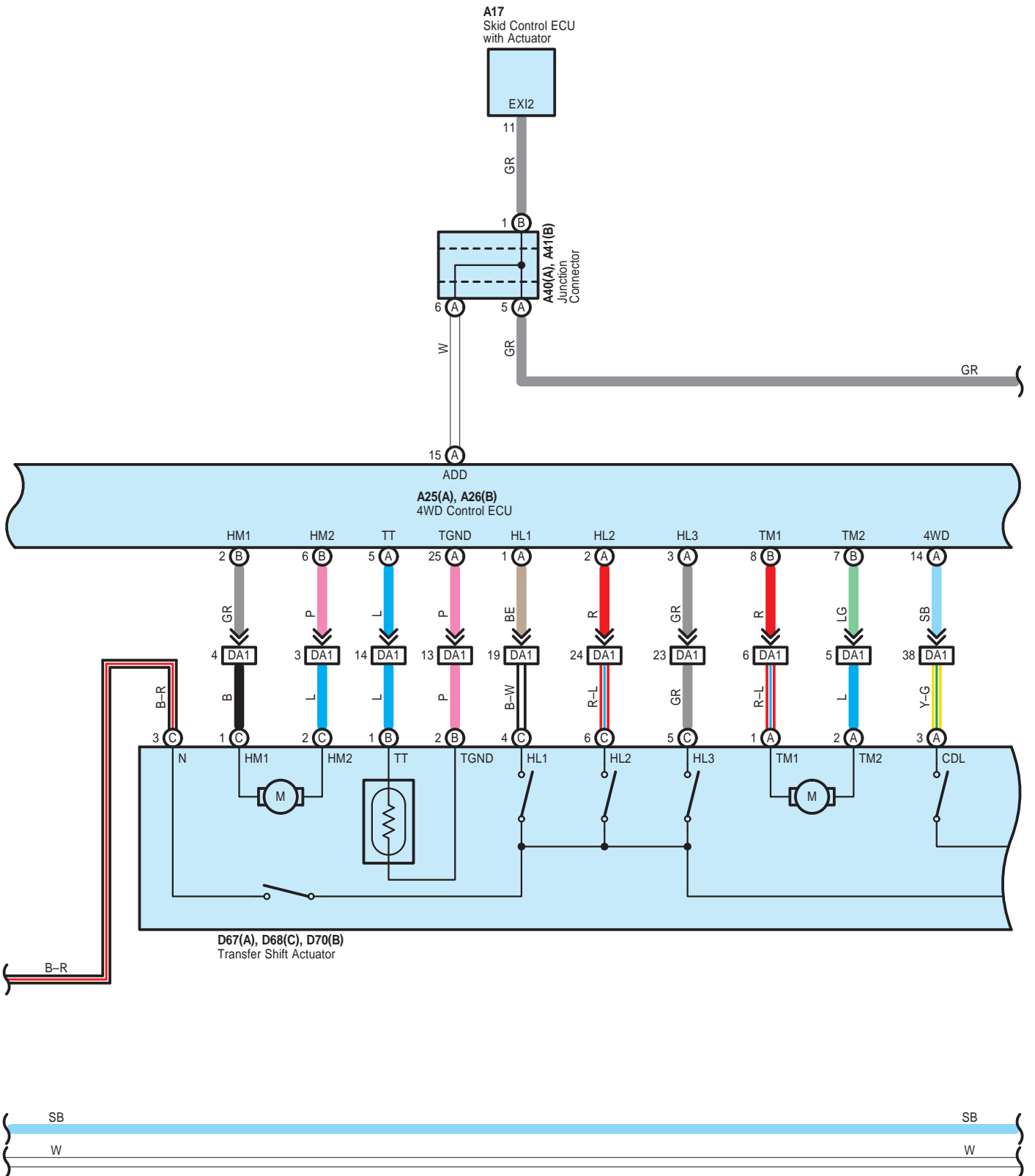

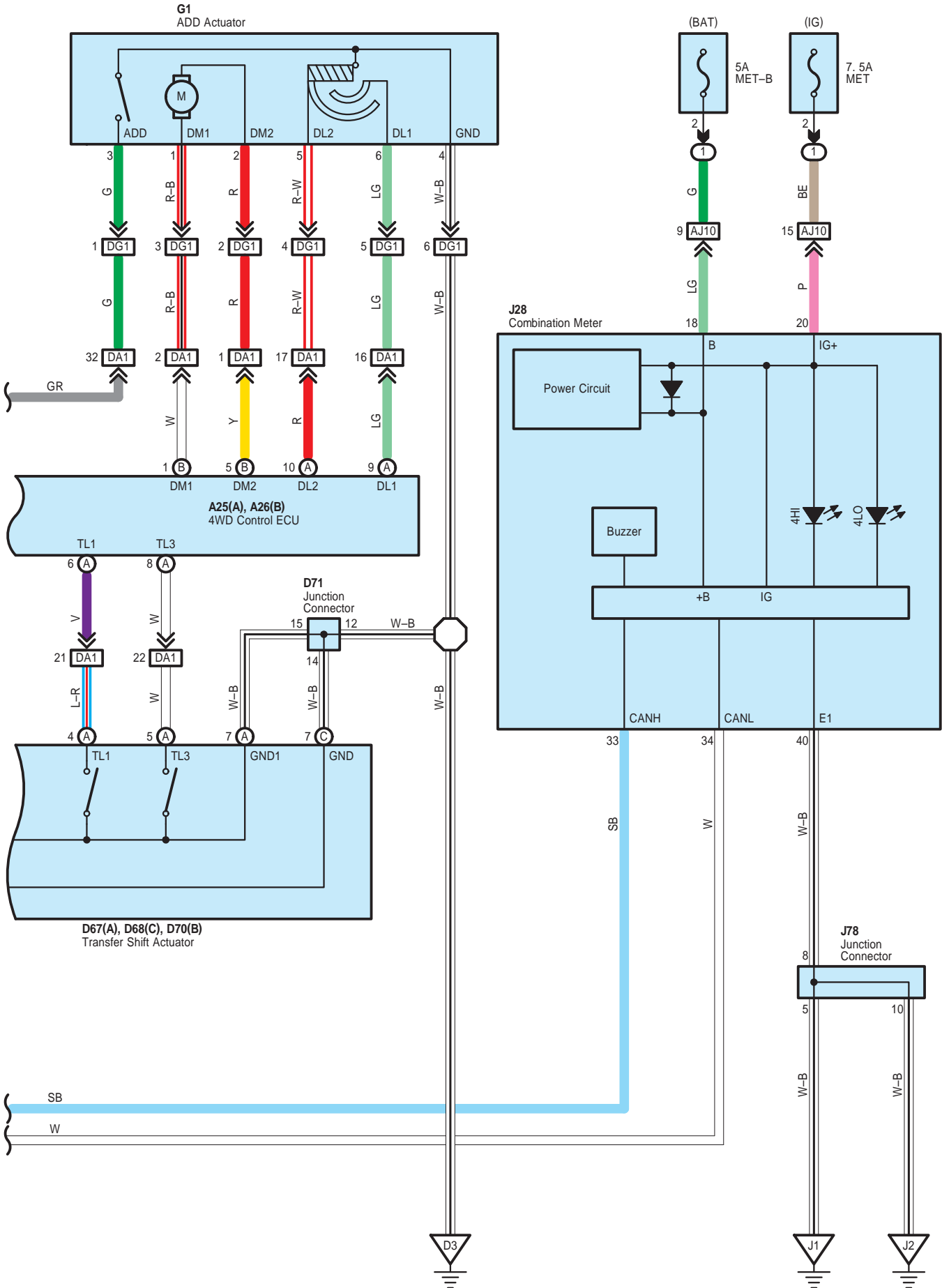

Multi Mode 4WD

A 17  
Black

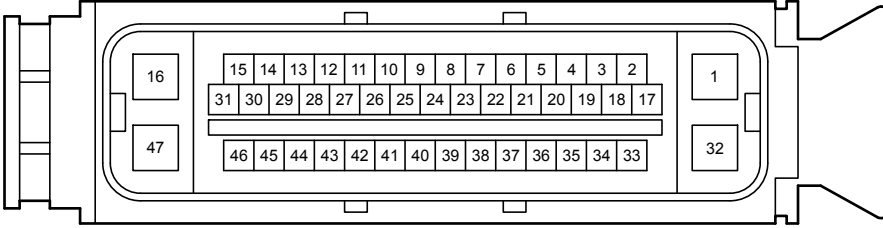

A 24  
Black

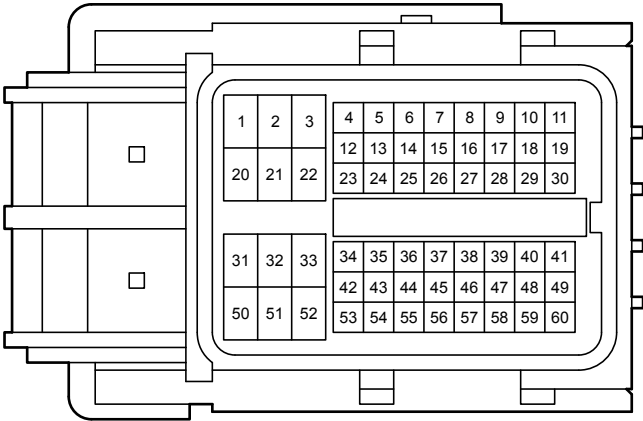

A 25  
Black

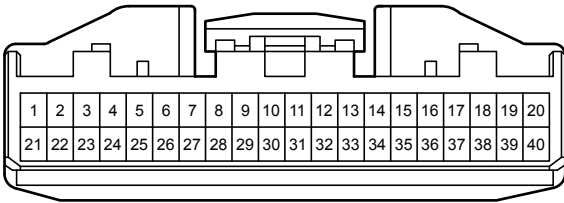

A 26  
Black

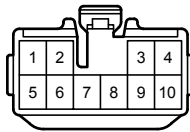

A 36  
White

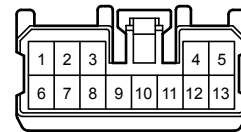

A 40  
White

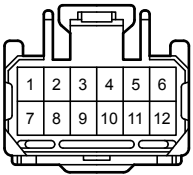

A 41  
White

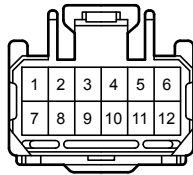

A 45  
Blue

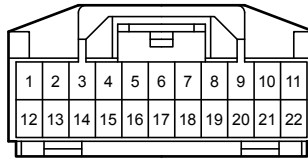

D 67  
Black

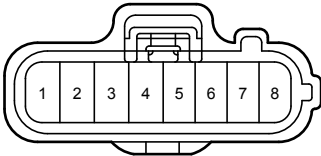

D 68  
Dark Gray

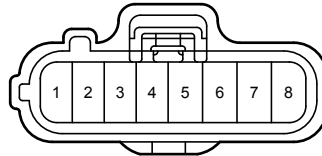

D 70  
Black

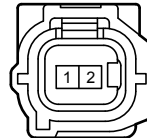

D 71  
White

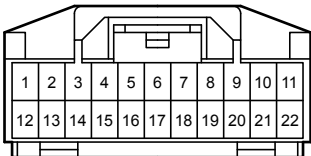

D 73  
Blue

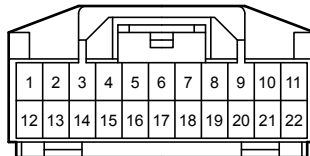

G 1  
Black

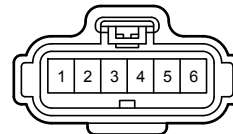

Multi Mode 4WD

J 28  
White

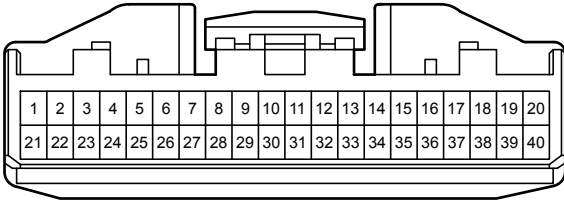

J 78  
White

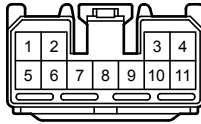

J113  
Gray

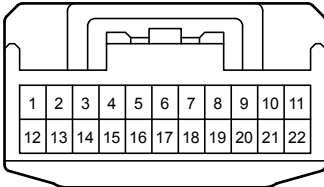

J118  
Gray

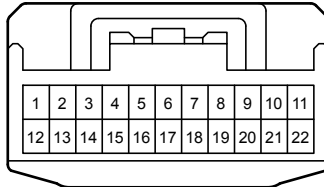

L 1  
Black

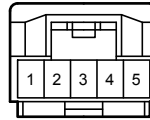

DB  
White

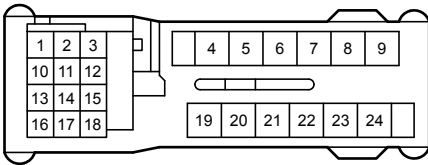

AJ3  
White

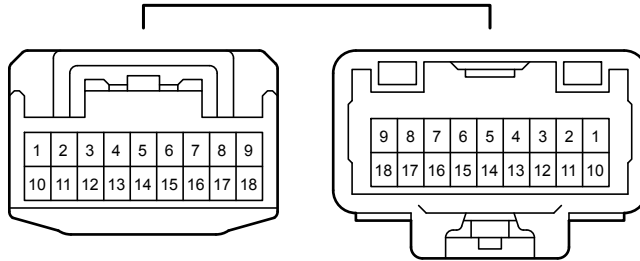

AJ10  
Gray

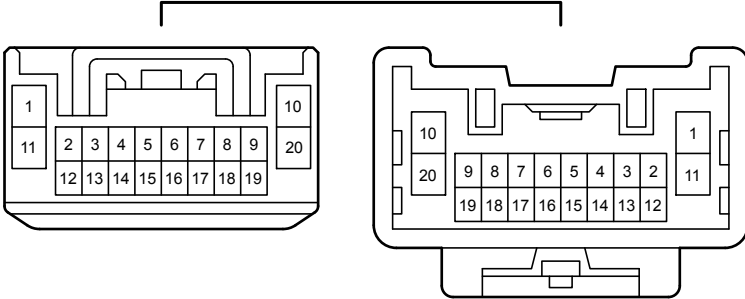

DA1  
White

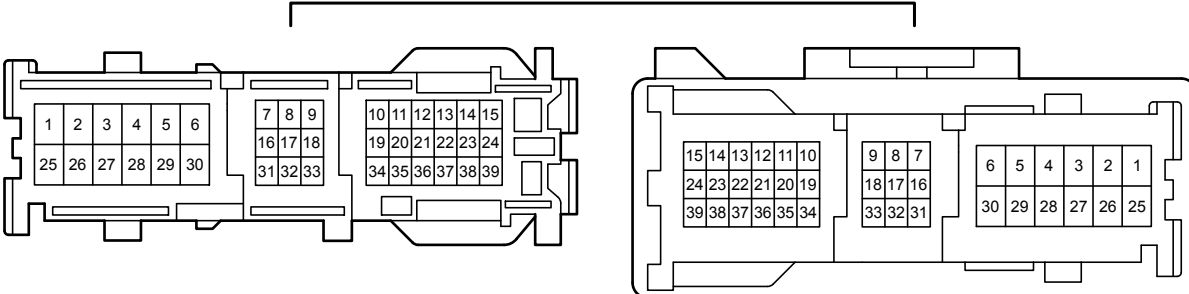

Multi Mode 4WD

DG1  
Black

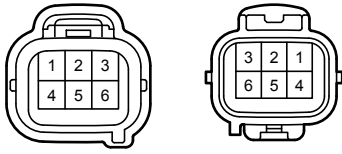

JL1  
White

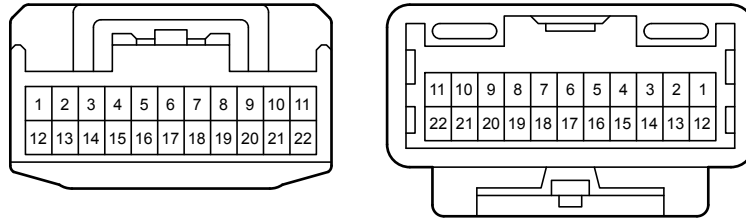

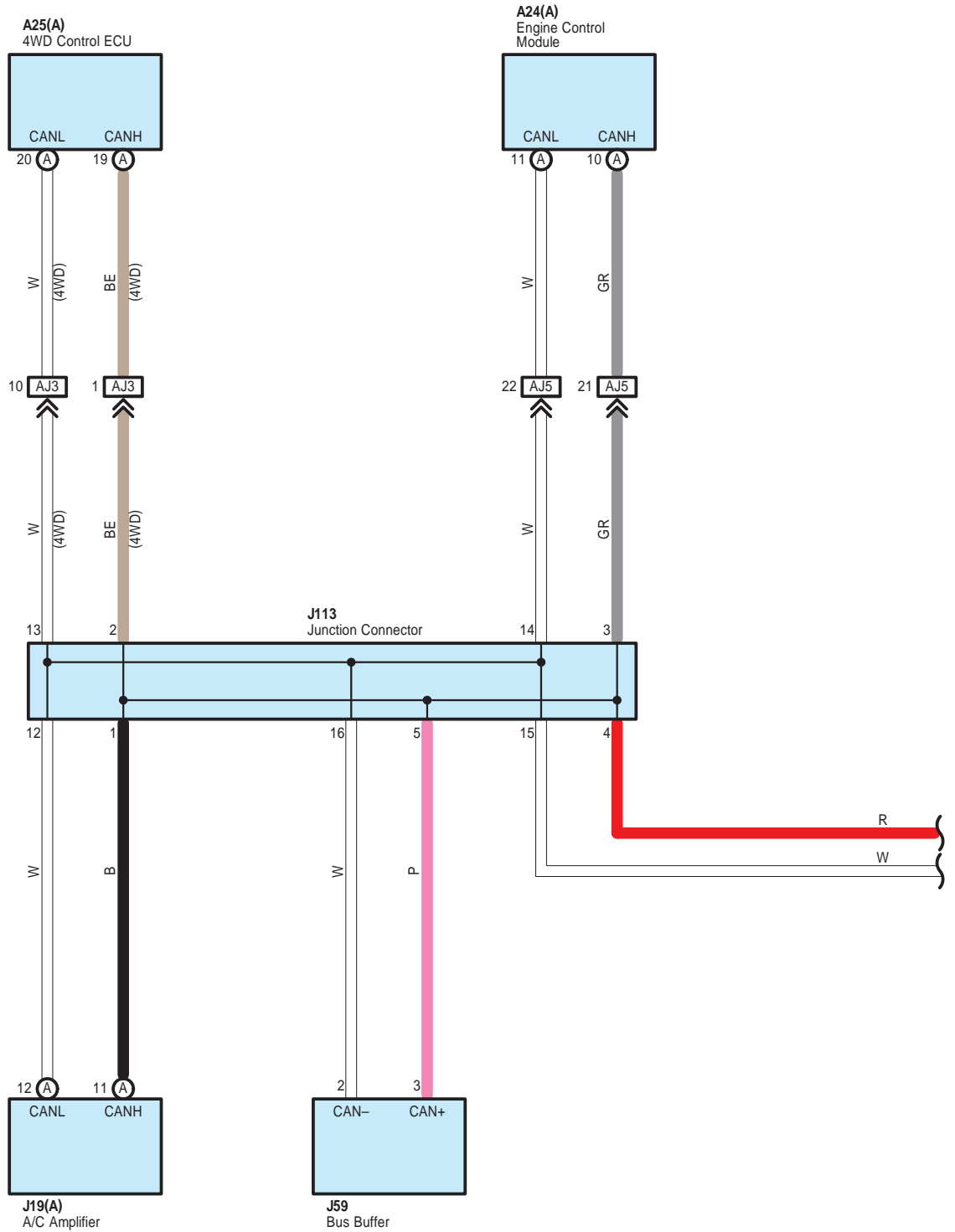



Multiplex Communication System <CAN>

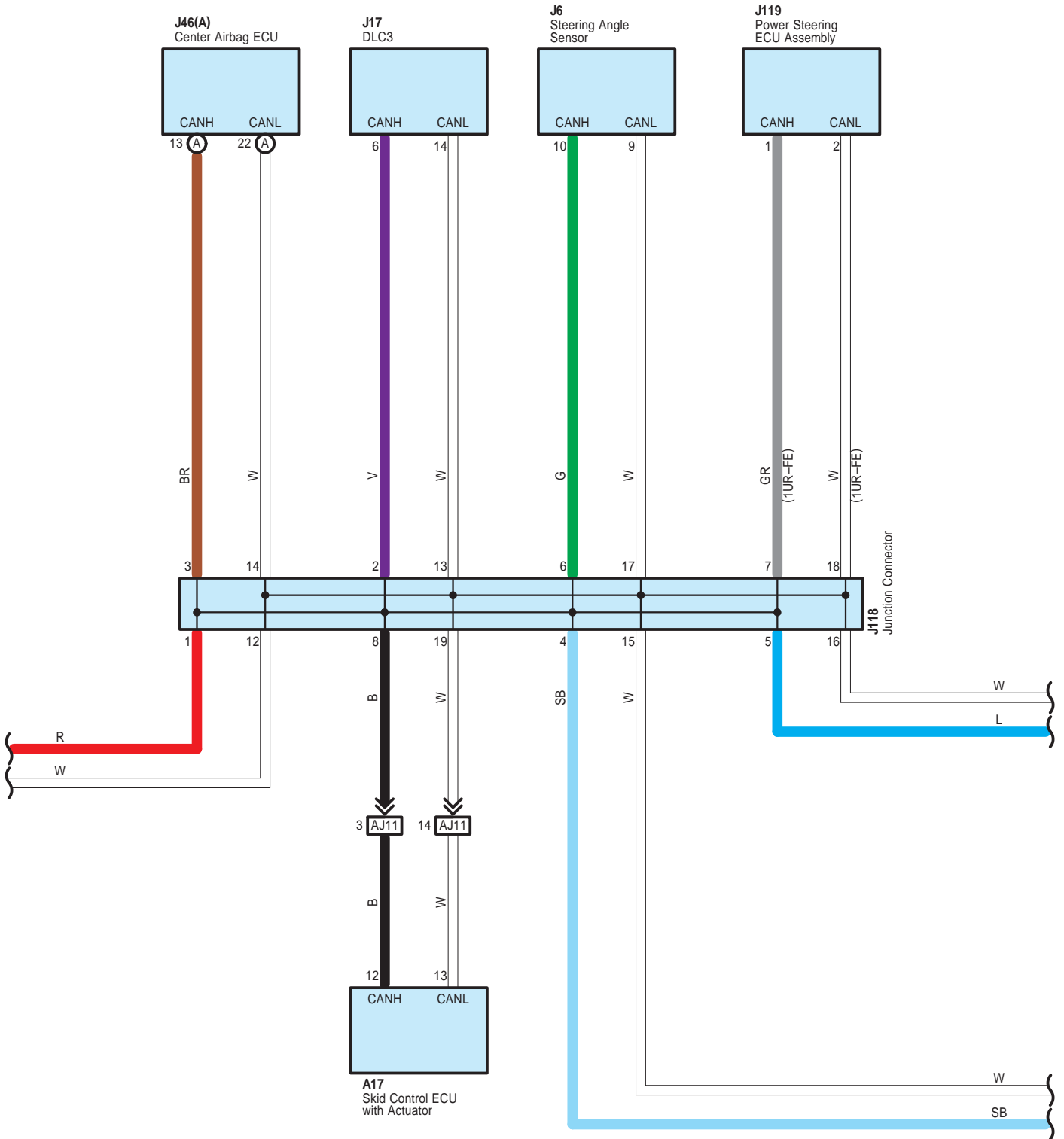

Multiplex Communication System <CAN>

\* 1 : w/ Seat Position Memory

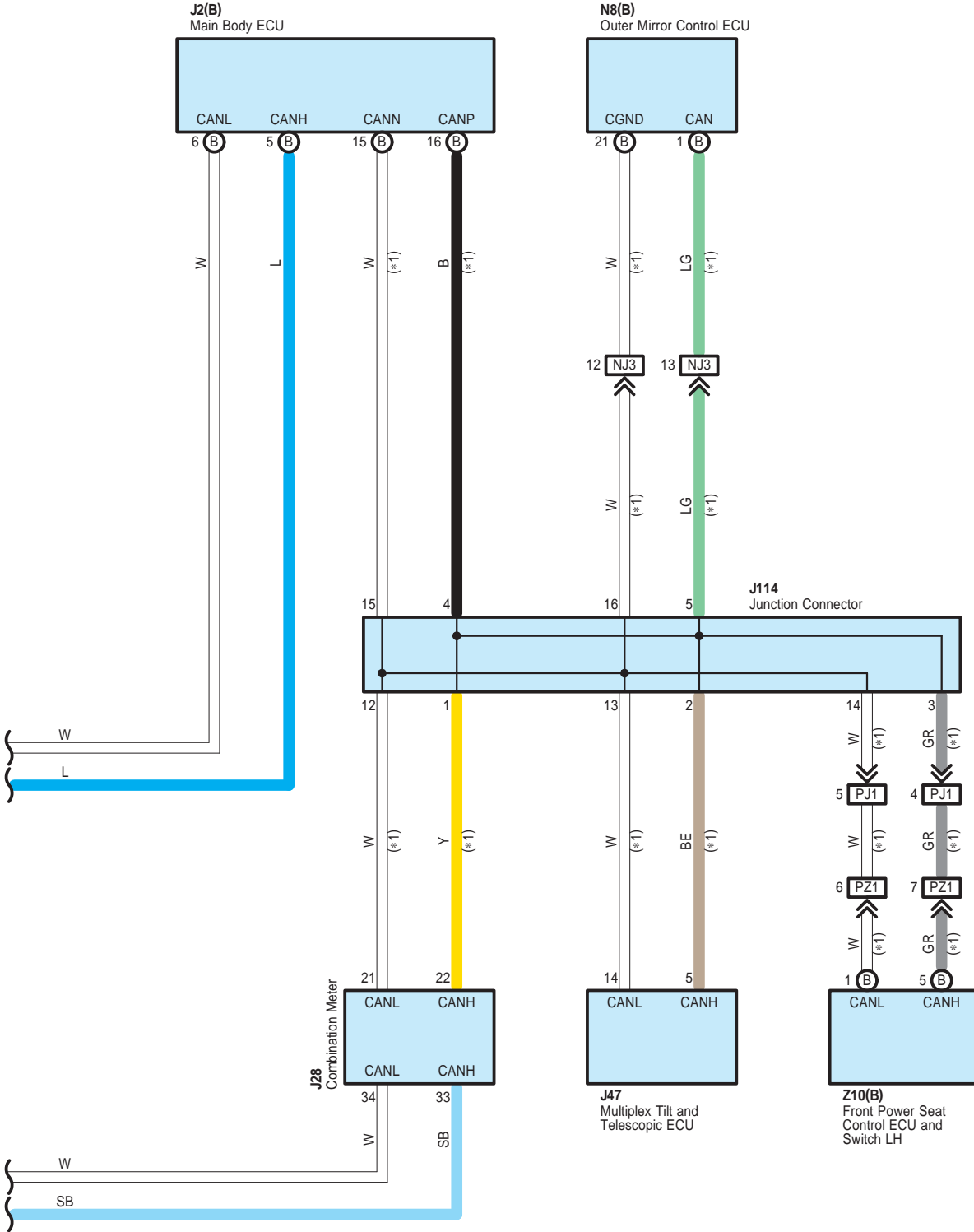

A 17  
Black

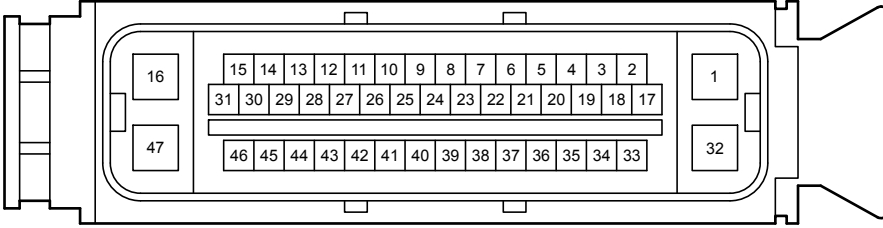

A 24  
Black

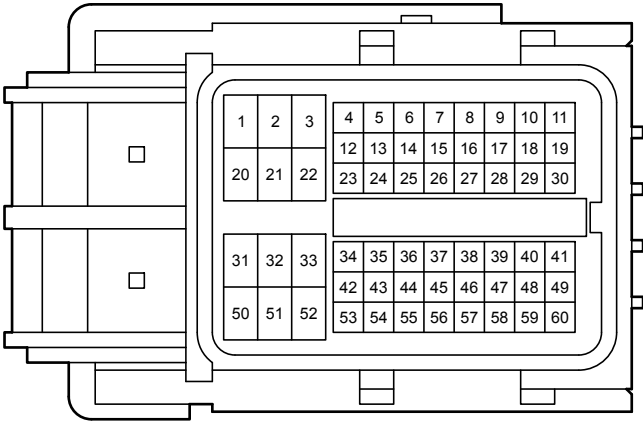

A 25  
Black

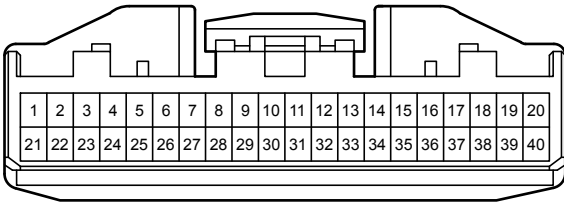

J 2  
White

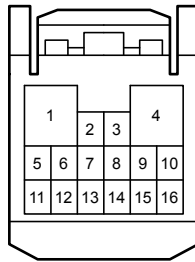

J 6  
Gray

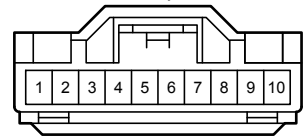

J 17  
White

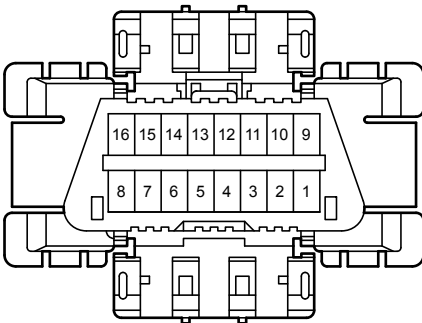

J 19  
White

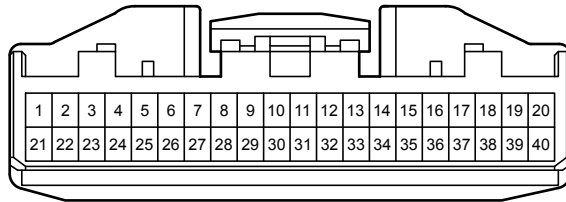

J 28  
White

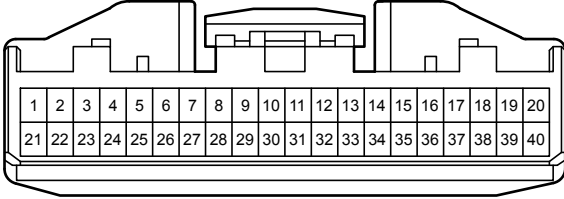

J 46  
Yellow

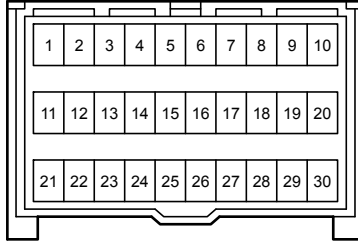

J 47  
White

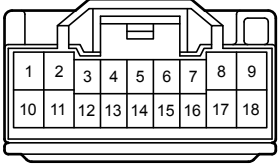

J 59  
White

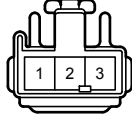

J113  
Gray

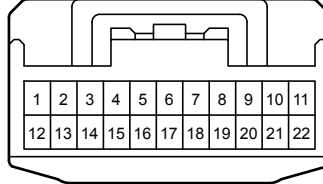

J114  
Gray

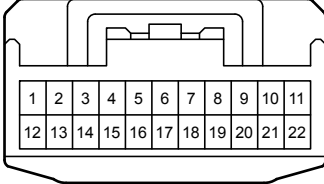

J118  
Gray

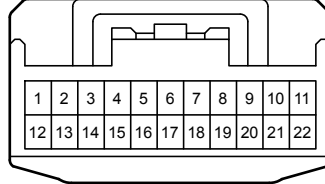

J119  
White

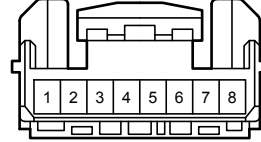

N 8  
White

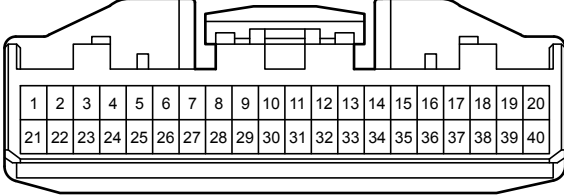

Z 10  
White

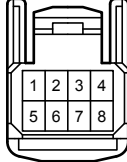

AJ3  
White

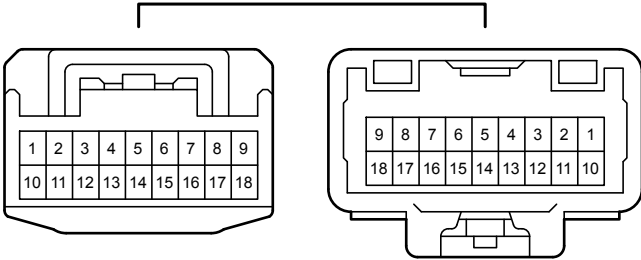

AJ5  
White

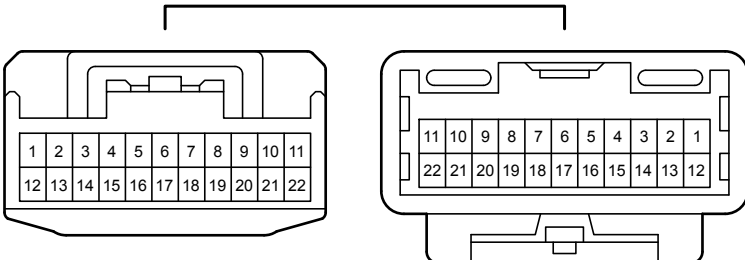

AJ11  
Gray

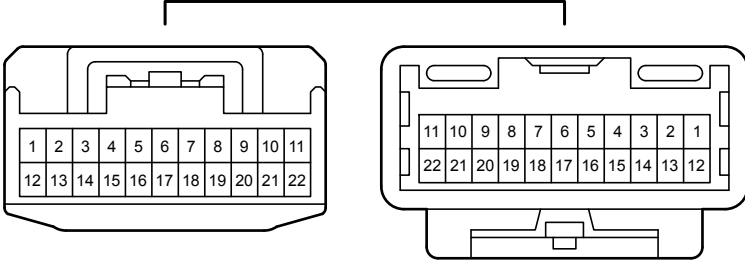

NJ3  
Blue

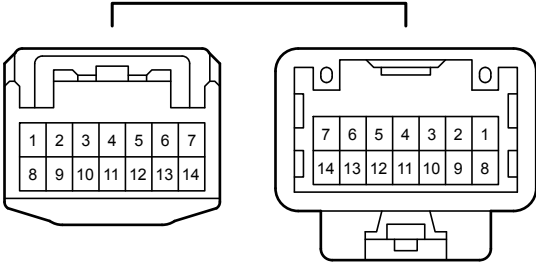

PJ1  
Black

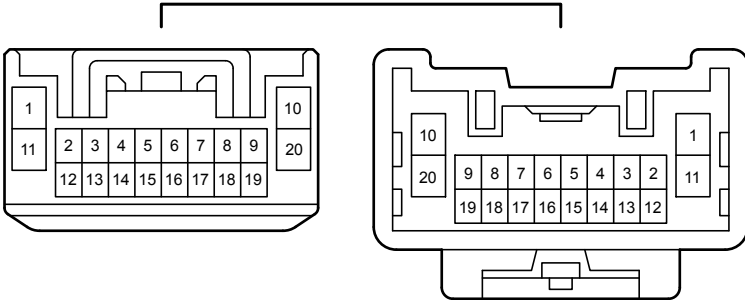

PZ1  
White

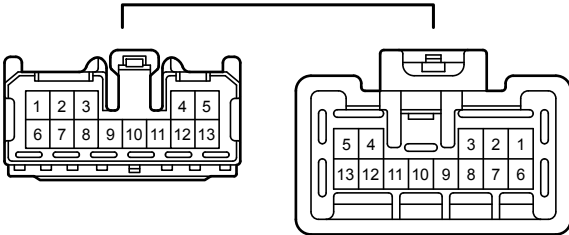

Parking Assist <Intuitive Parking Assist>

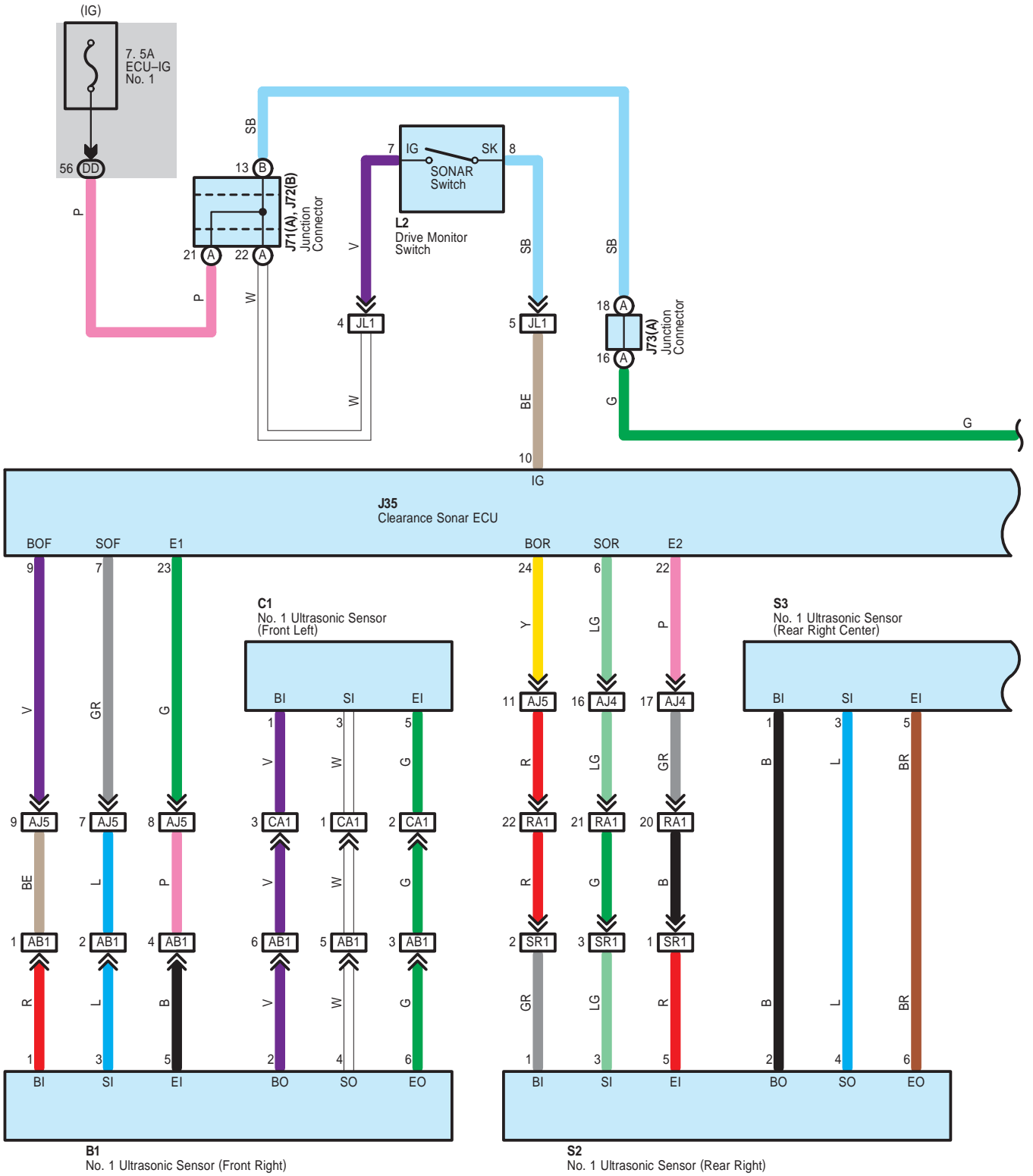



Parking Assist <Intuitive Parking Assist>

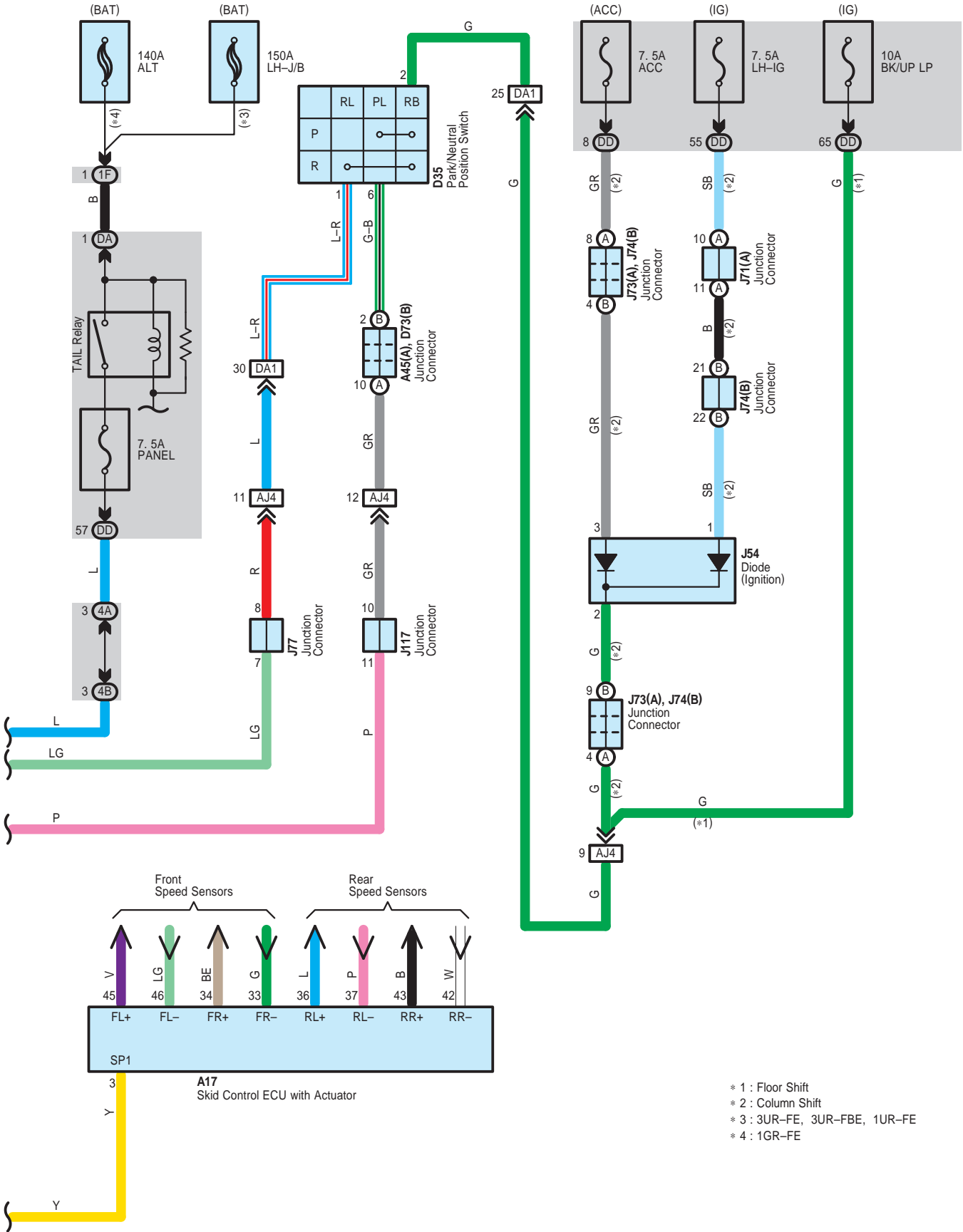



Parking Assist <Intuitive Parking Assist>

A 17  
Black

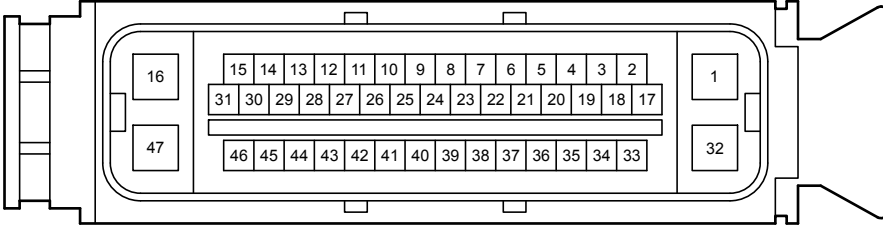

A 45  
Blue

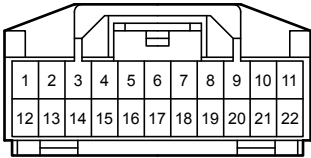

B 1  
Black

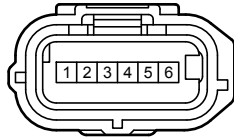

C 1  
Black

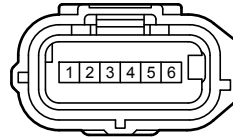

D 35  
Gray

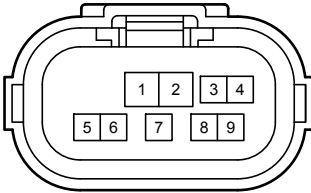

D 73  
Blue

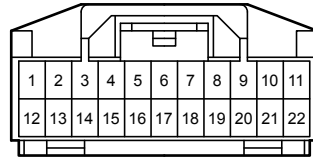

J 28  
White

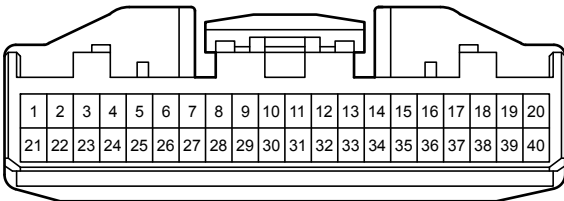

J 35  
White

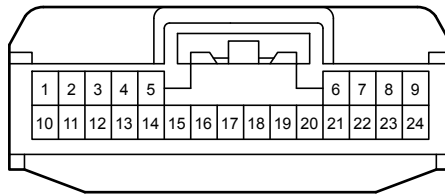

J 54  
Orange

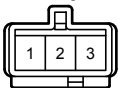

J 71  
Black

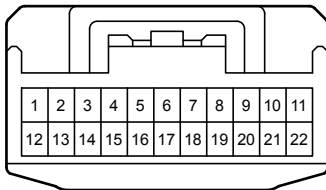

J 72  
Black

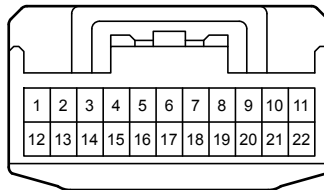

J 73  
Black

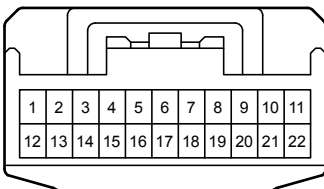

J 74  
Black

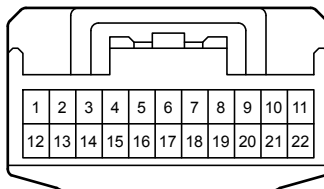

J 75  
White

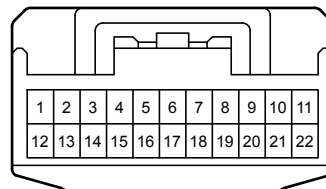

Parking Assist <Intuitive Parking Assist>

J 77  
Gray

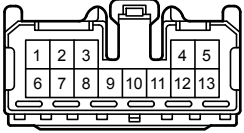

J117  
Black

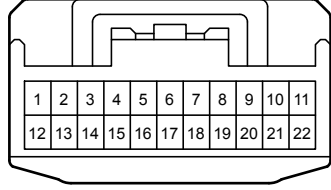

K 20  
White

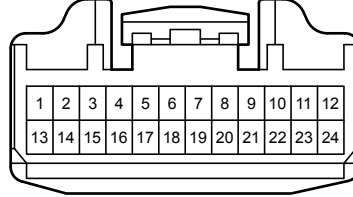

L 2  
Black

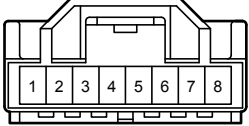

S 1  
Black

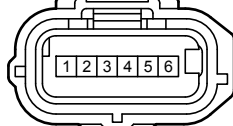

S 2  
Black

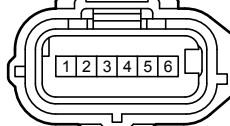

S 3  
Black

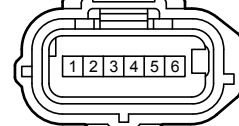

S 4  
Black

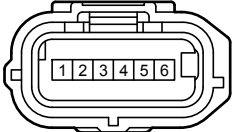

1F

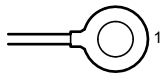

4A  
Black

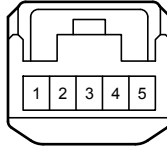

4B  
White

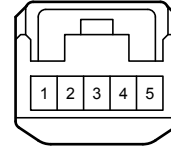

DA  
White

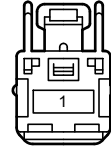

DD  
White

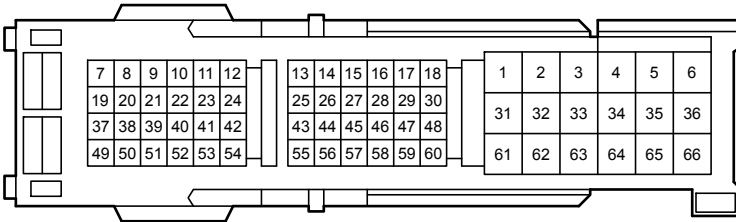

AB1  
White

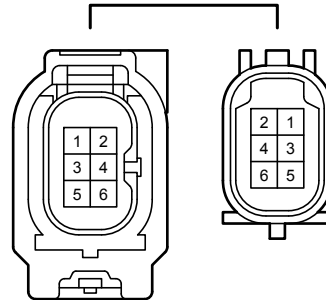

AJ4  
White

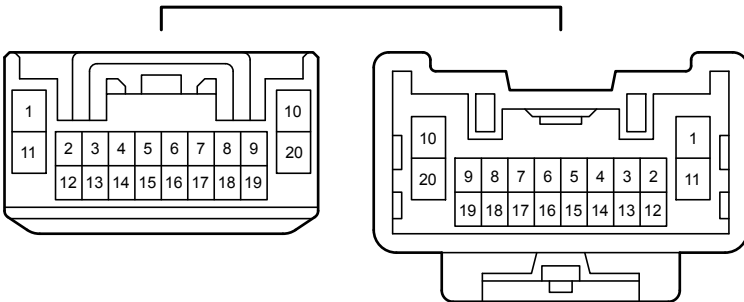

AJ5  
White

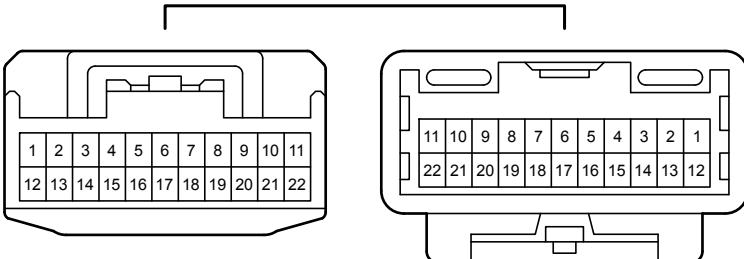

Parking Assist <Intuitive Parking Assist>

AJ11  
Gray

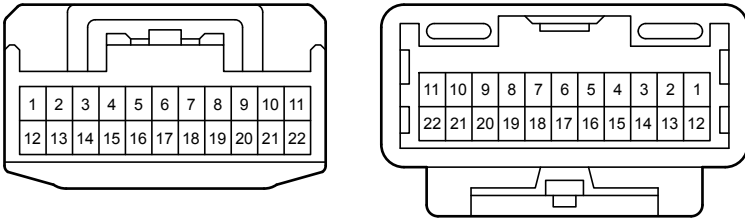

CA1  
Black

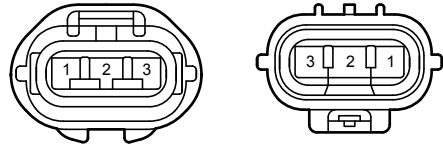

DA1  
White

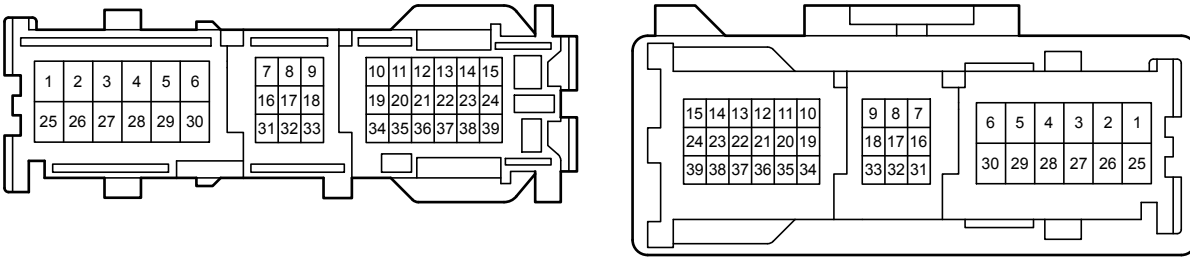

JK2  
White

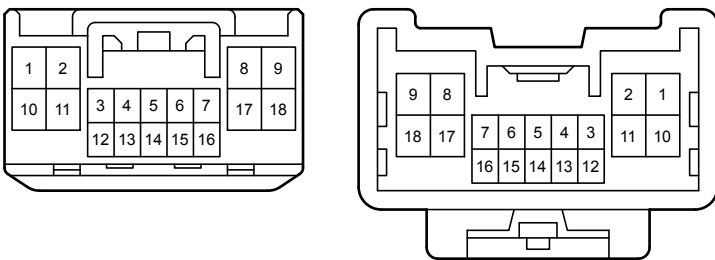

JL1  
White

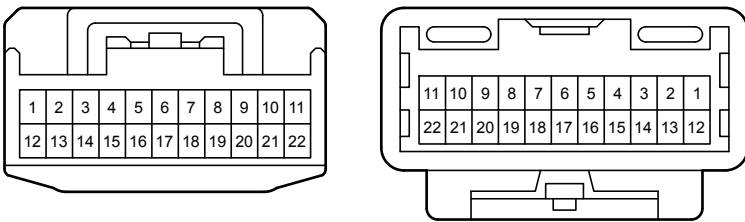

RA1  
White

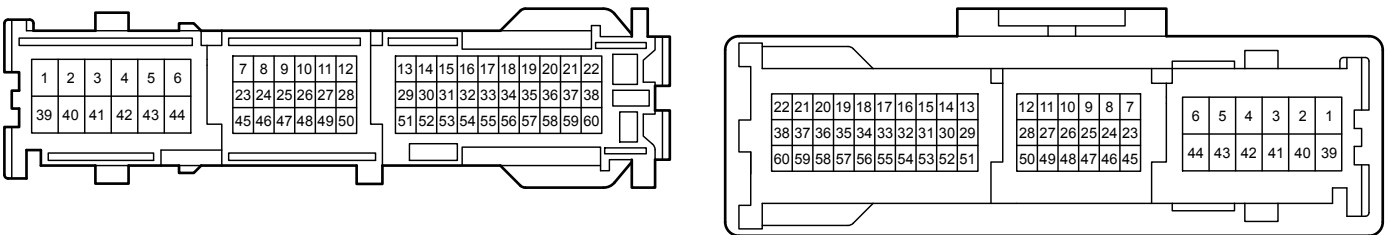

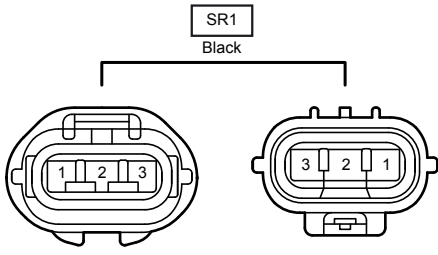

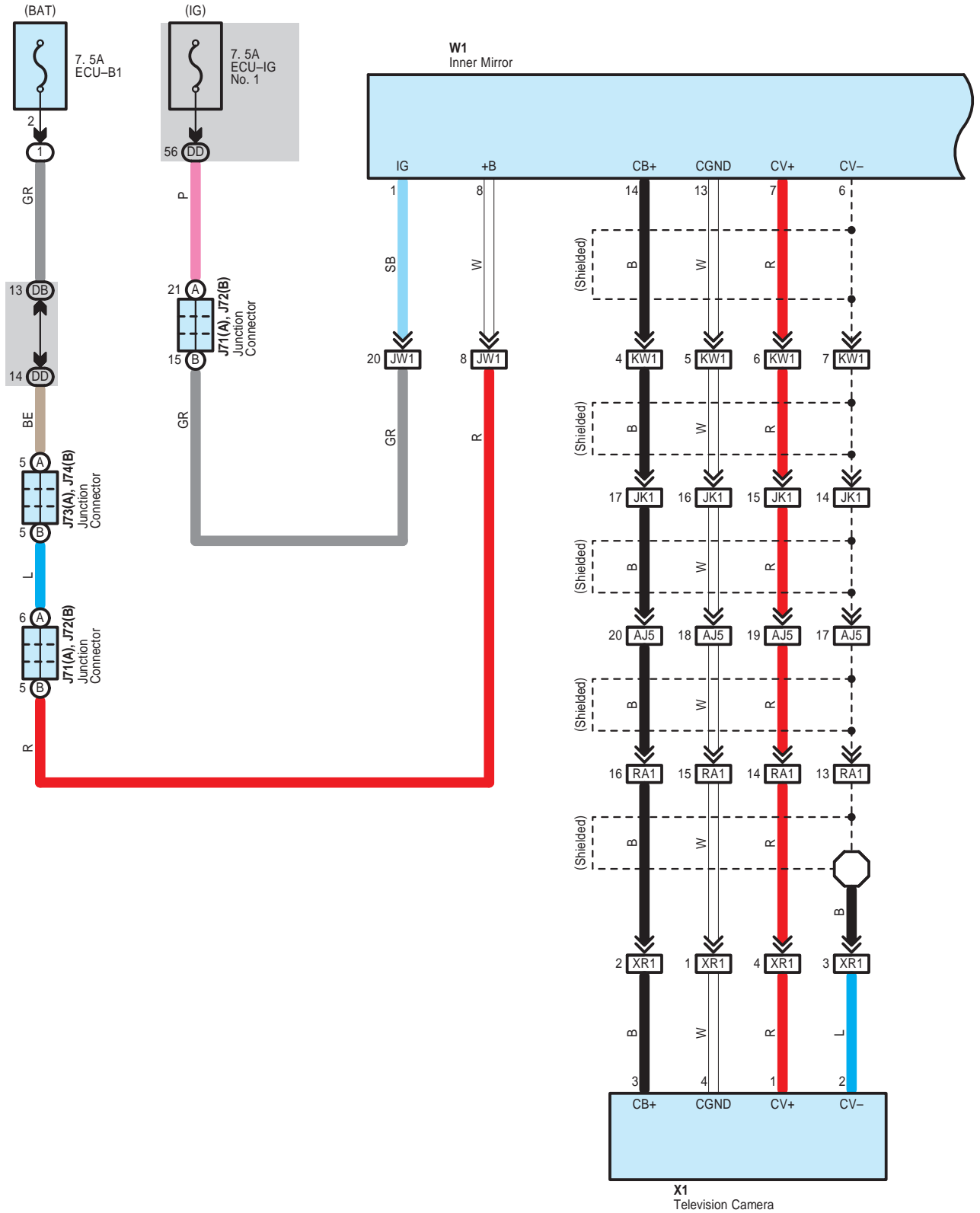

Parking Assist <Rear View Monitor w/o Navigation System>

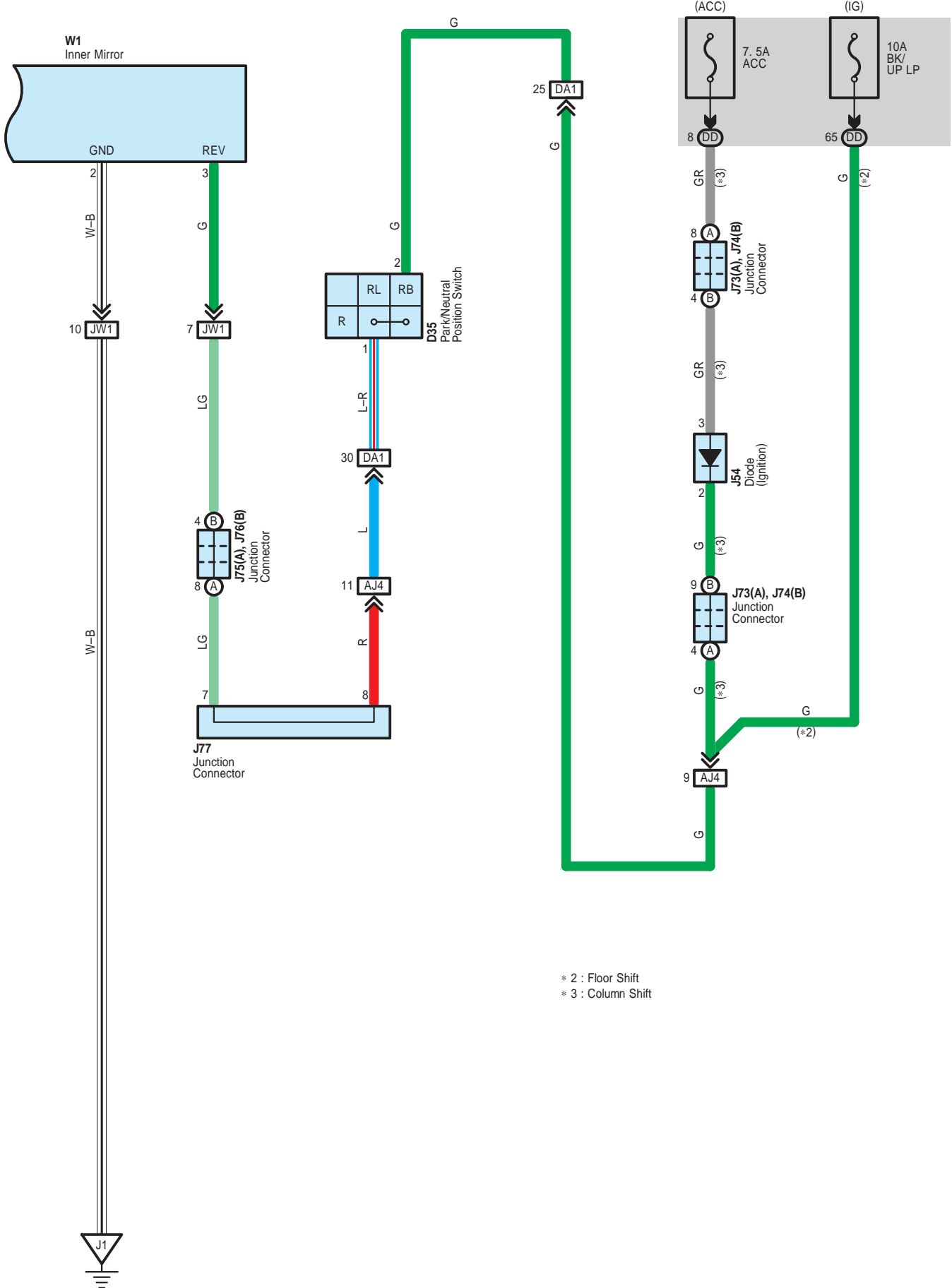

**Parking Assist <Rear View Monitor w/o Navigation System>**

D 35  
Gray

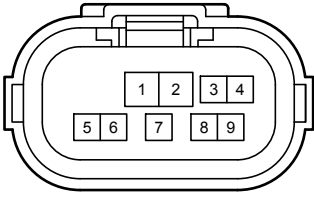

J 54  
Orange

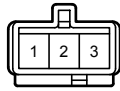

J 71  
Black

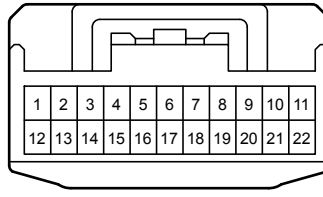

J 72  
Black

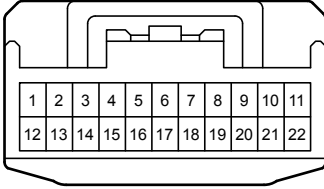

J 73  
Black

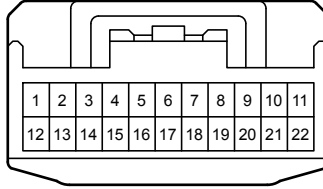

J 74  
Black

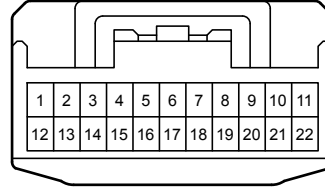

J 75  
White

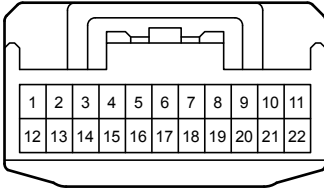

J 76  
White

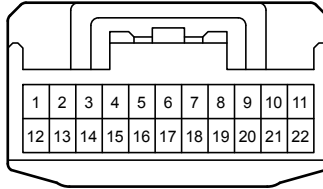

J 77  
Gray

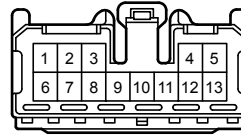

W 1  
Black

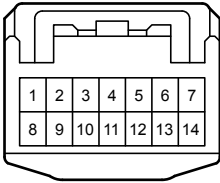

X 1  
Dark Gray

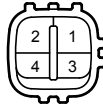

DB  
White

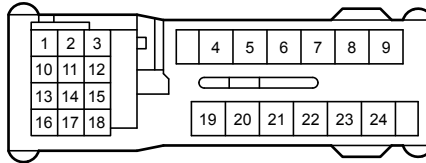

DD  
White

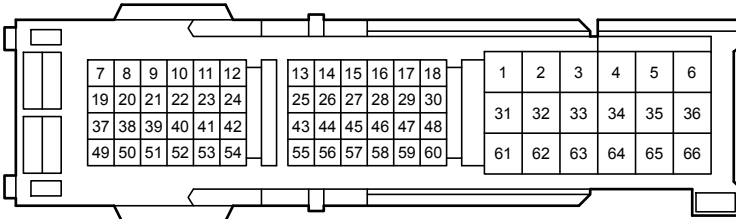

AJ4  
White

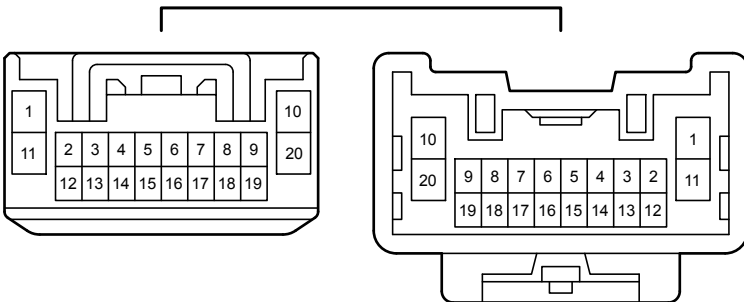

Parking Assist <Rear View Monitor w/o Navigation System>

AJ5  
White

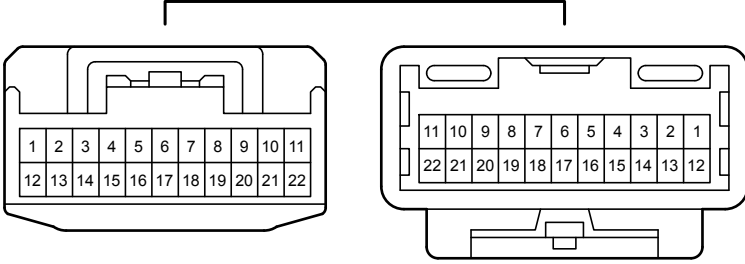

DA1  
White

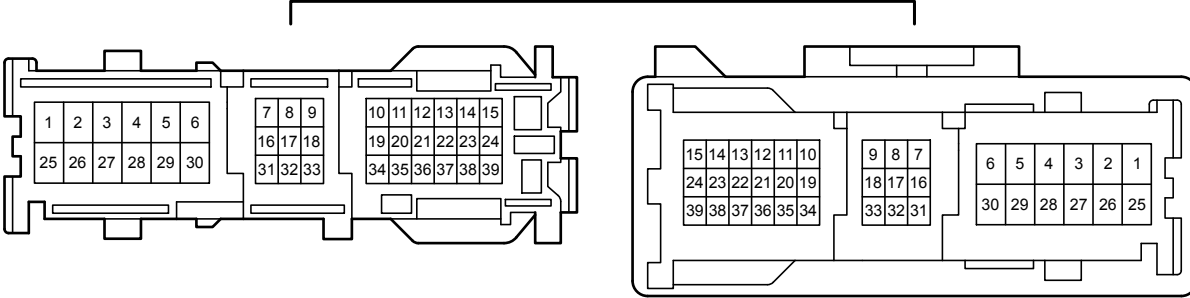

JK1  
White

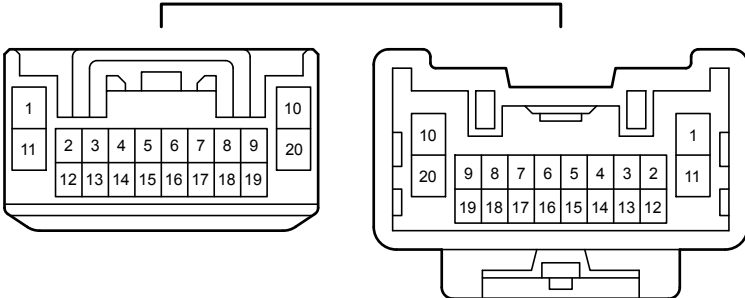

JW1  
White

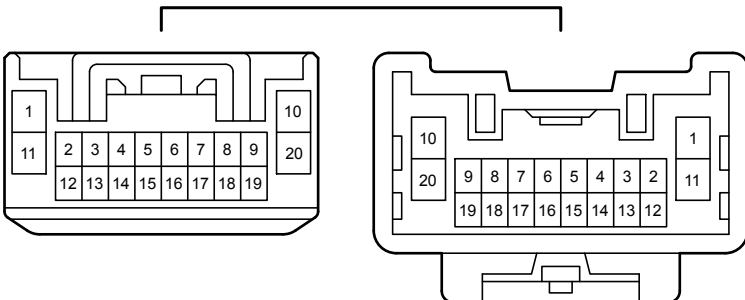

KW1  
White

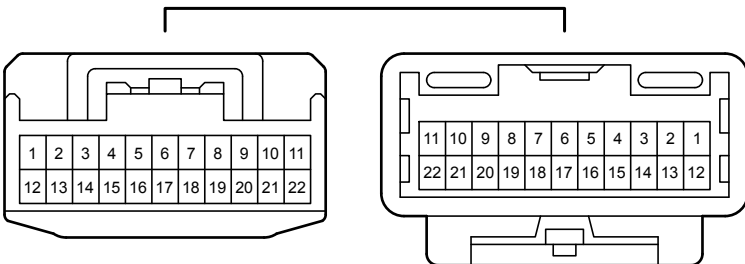



Parking Assist <Rear View Monitor w/o Navigation System>

RA1  
White

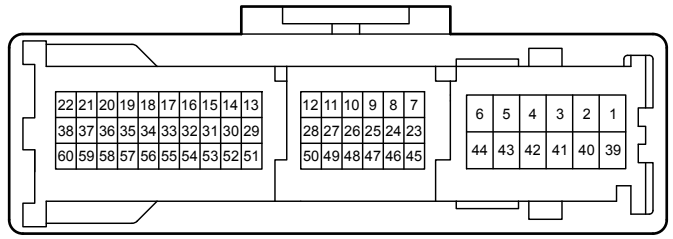
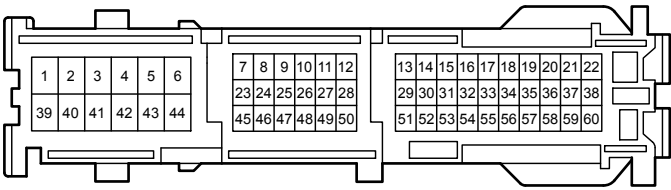

XR1  
White

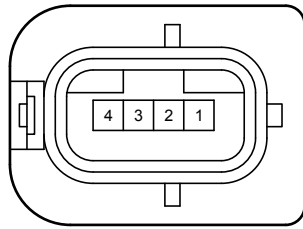
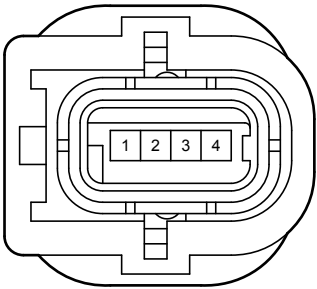

Power Outlet <12V>

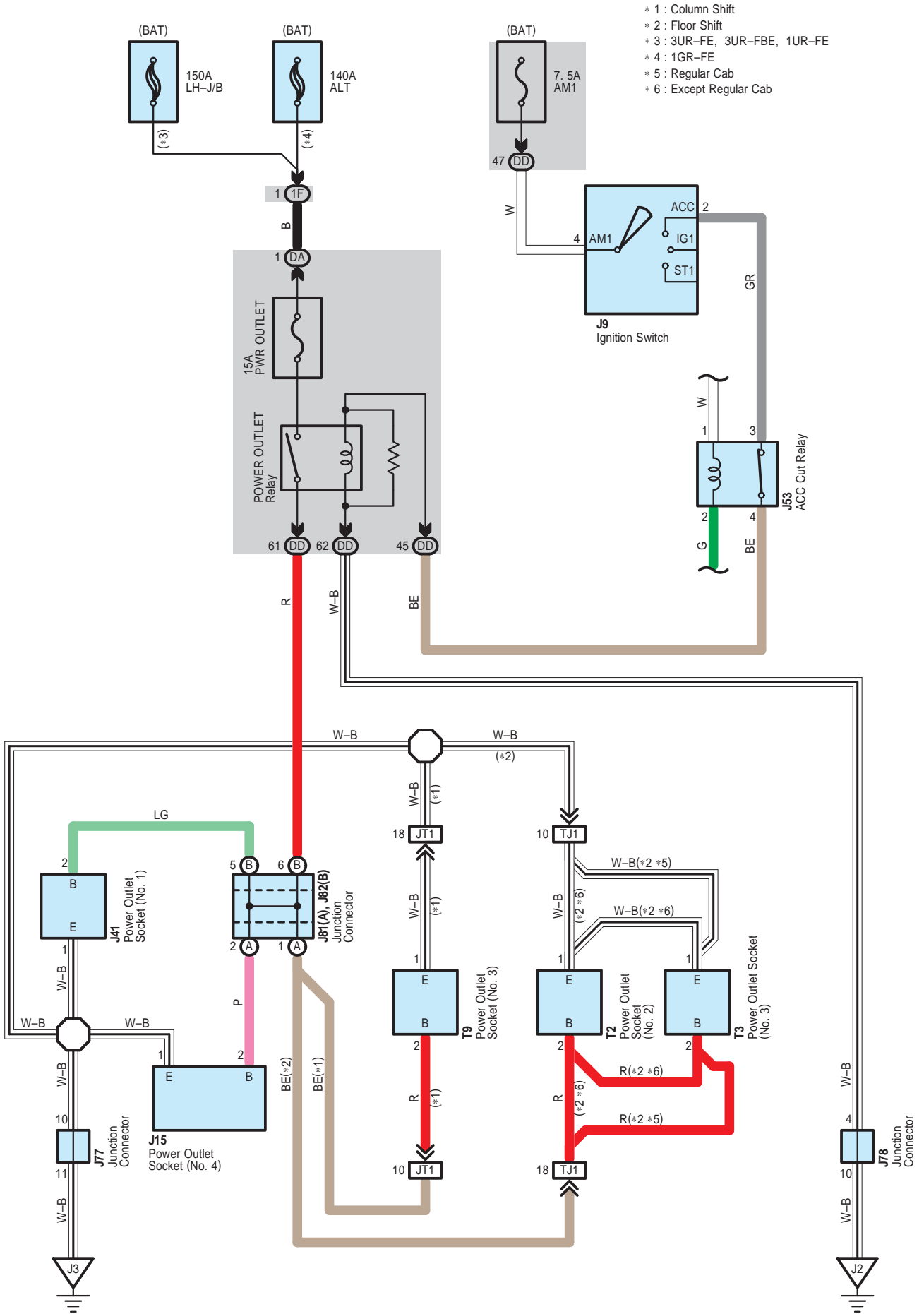

- \* 1 : Column Shift
- \* 2 : Floor Shift
- \* 3 : 3UR-FE, 3UR-FBE, 1UR-FE
- \* 4 : 1GR-FE
- \* 5 : Regular Cab
- \* 6 : Except Regular Cab

Power Outlet <12V>

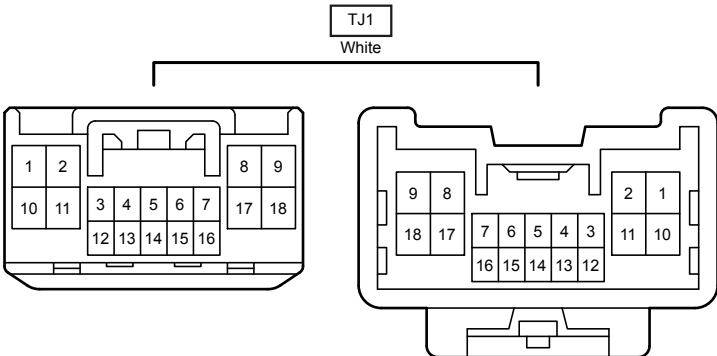
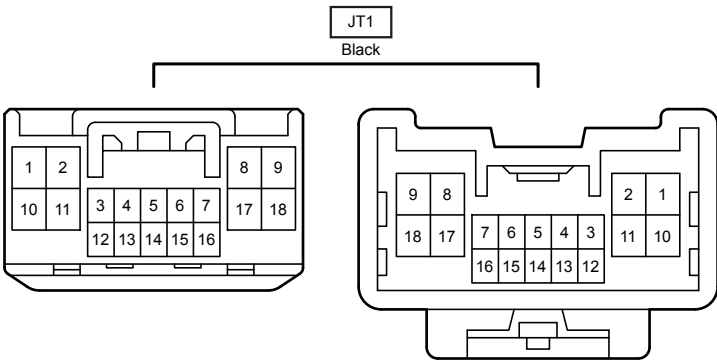
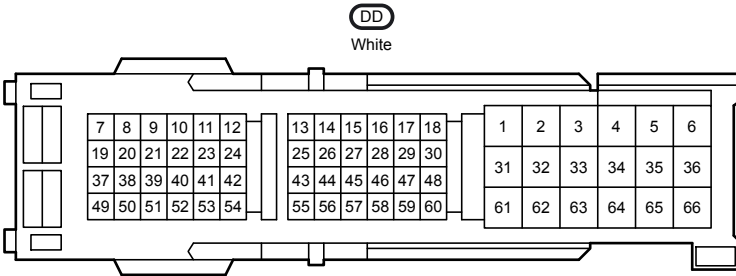
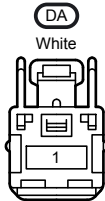
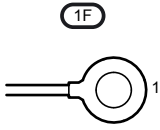
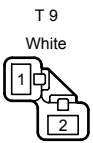
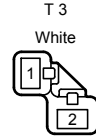
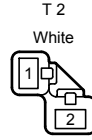
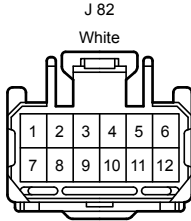
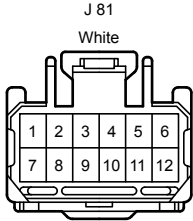
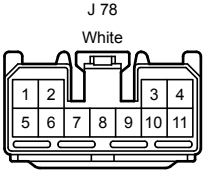
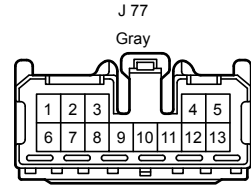
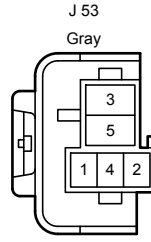
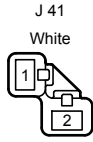
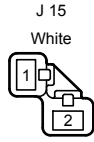
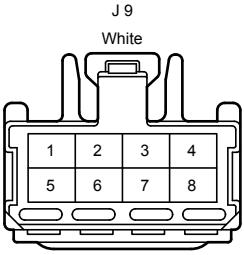

Power Outlet <115V>

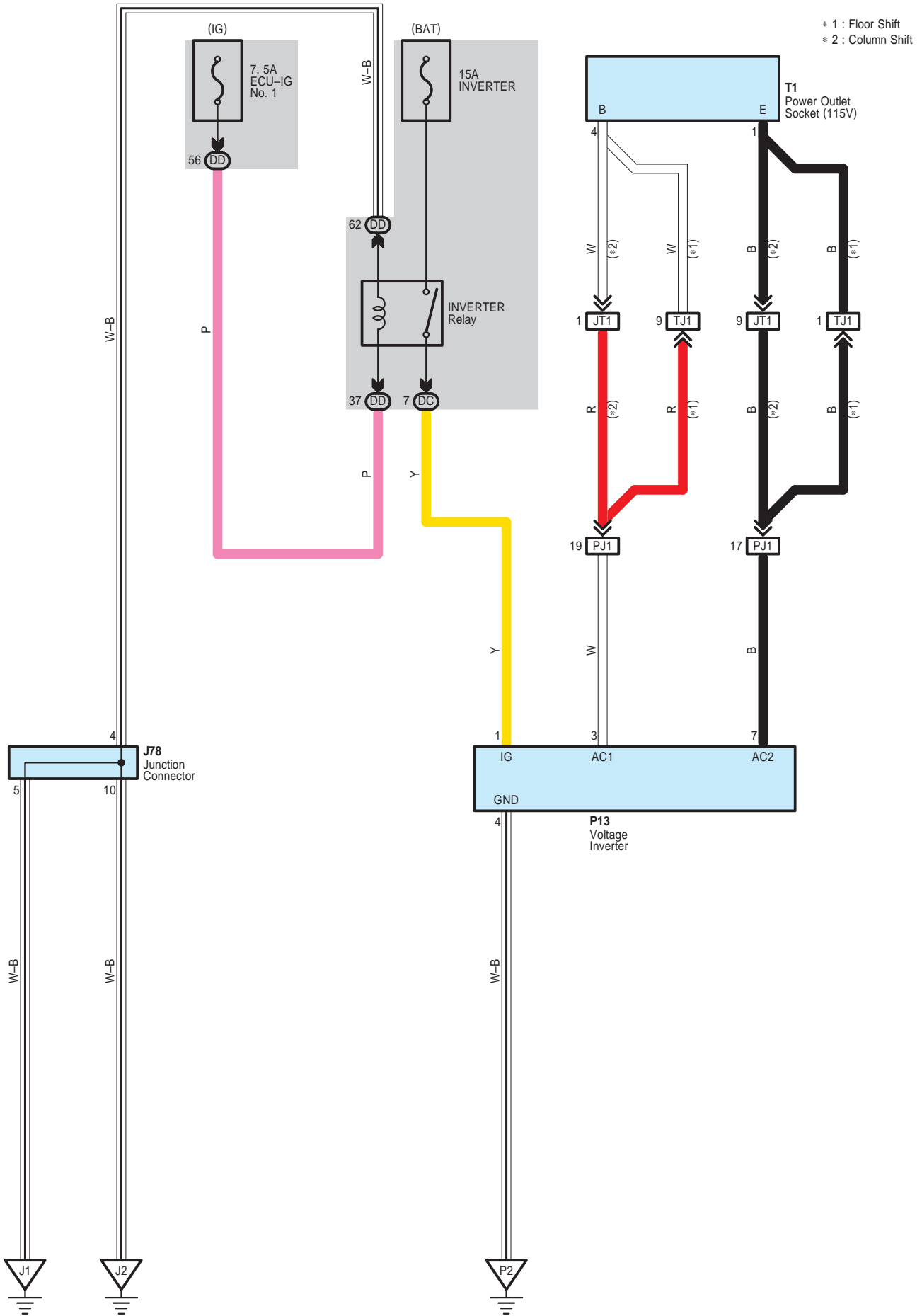

\* 1 : Floor Shift  
\* 2 : Column Shift

Power Outlet <115V>

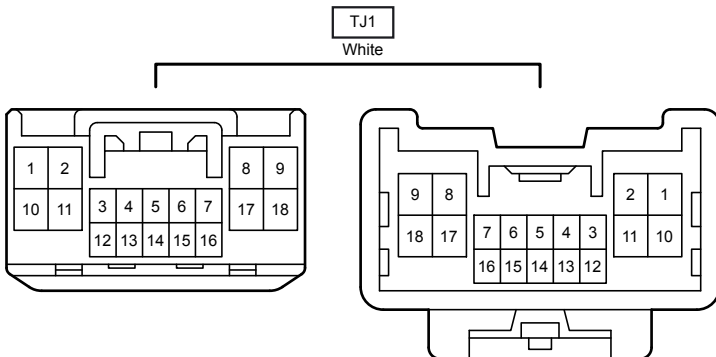
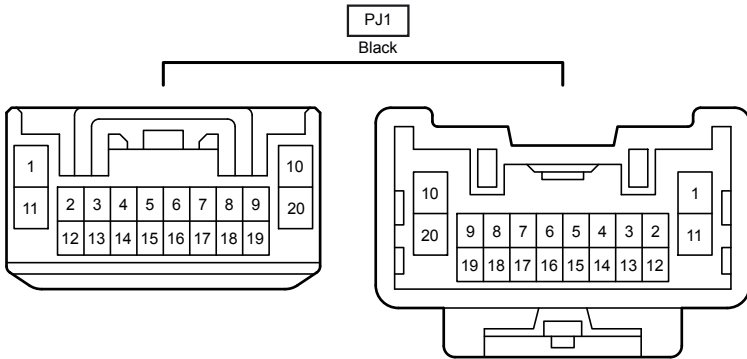
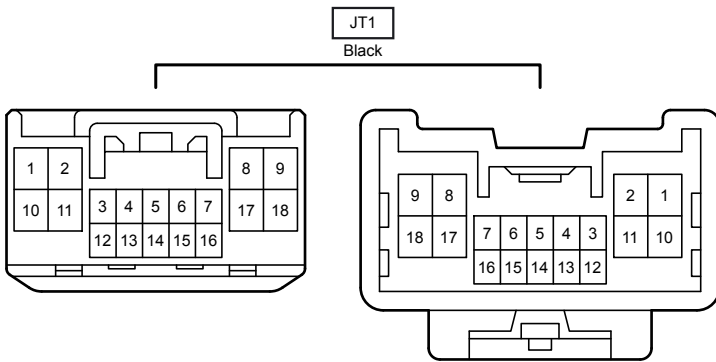
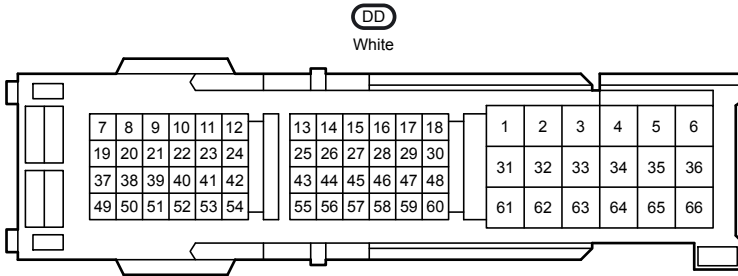
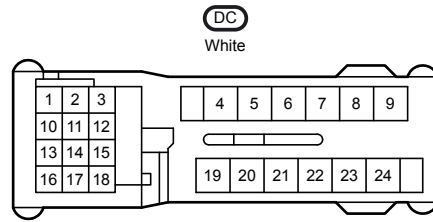
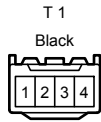
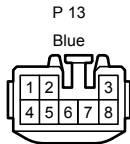
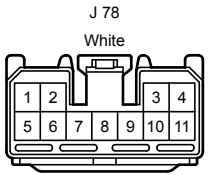

Power Steering

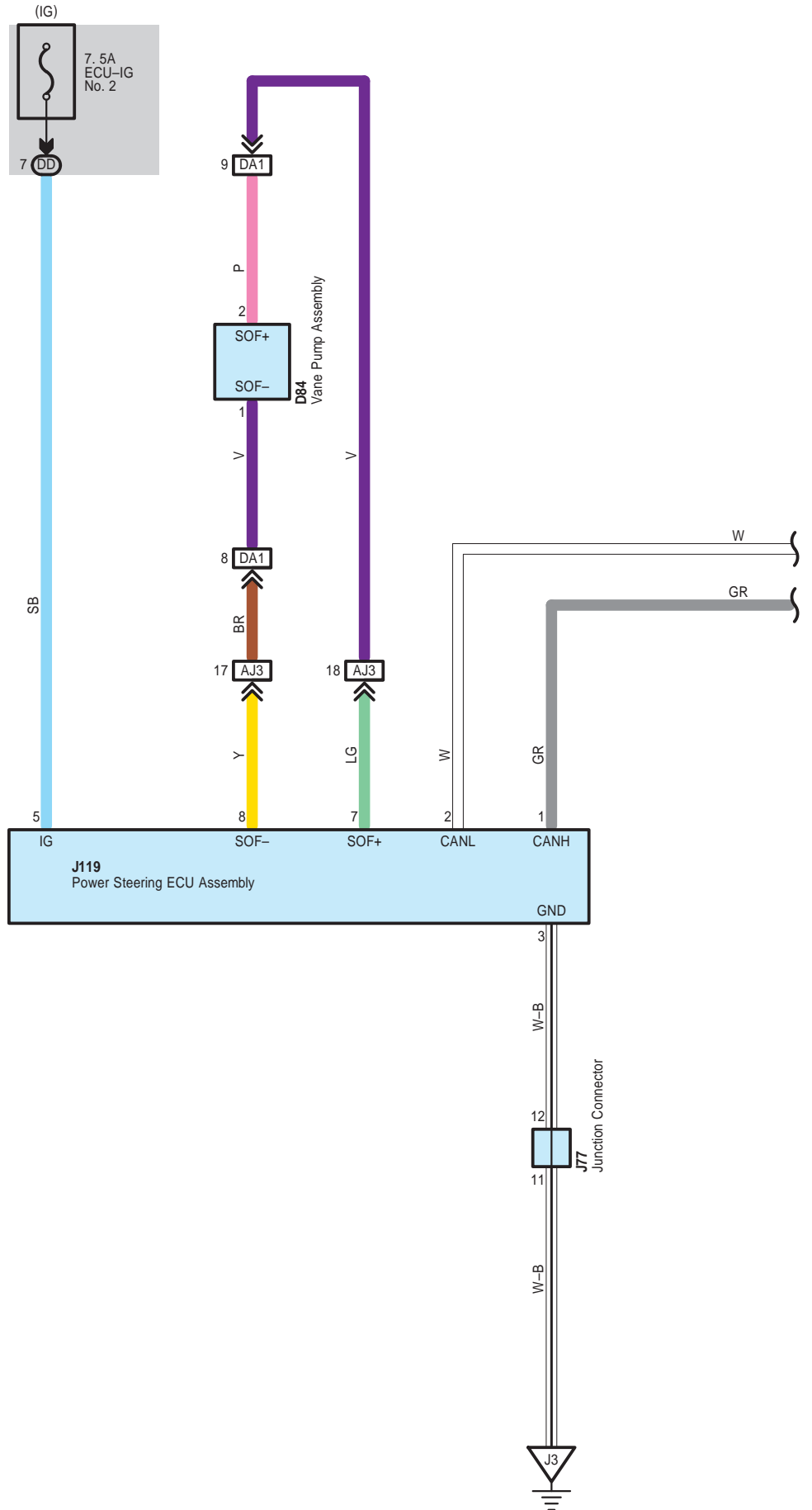



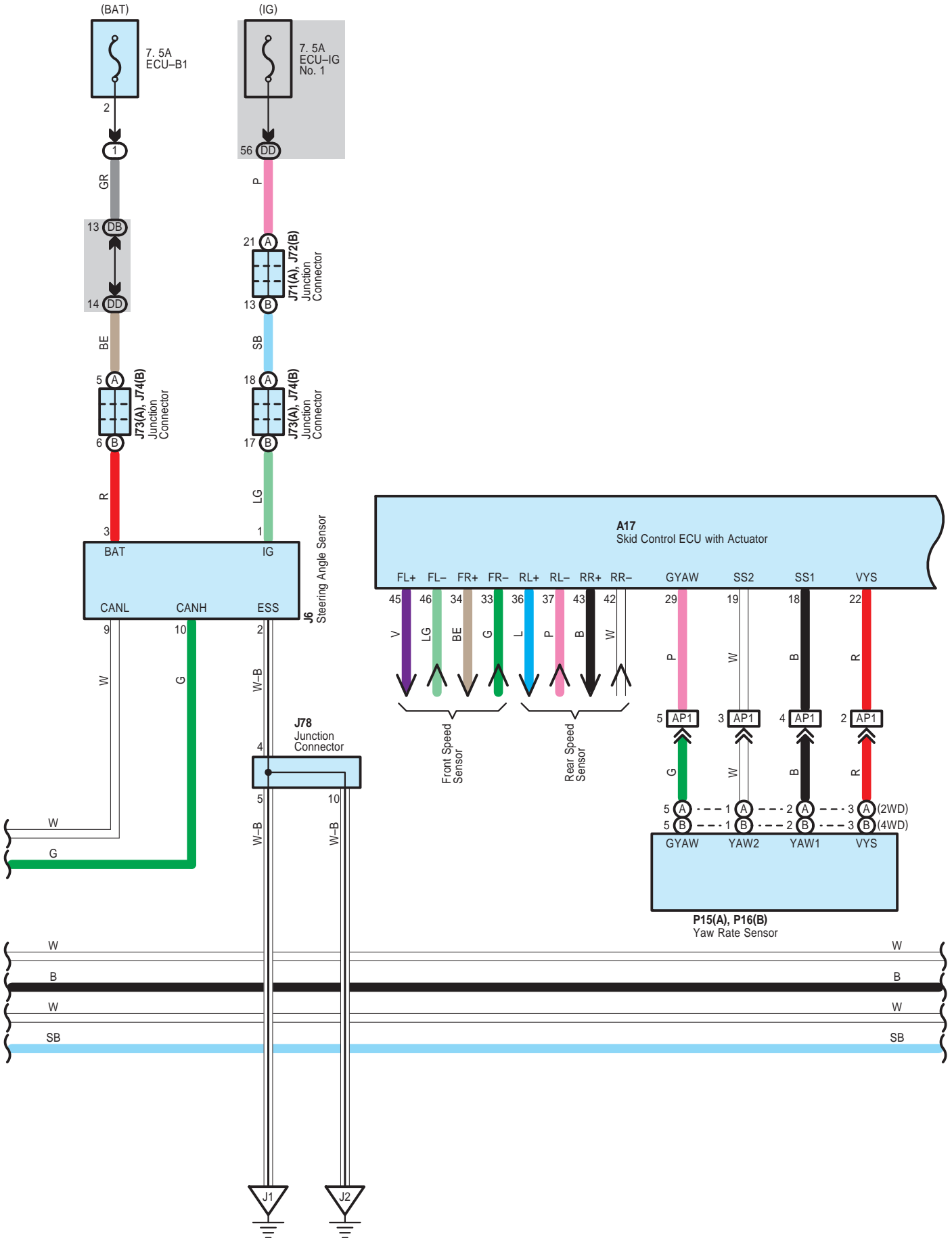



# Power Steering

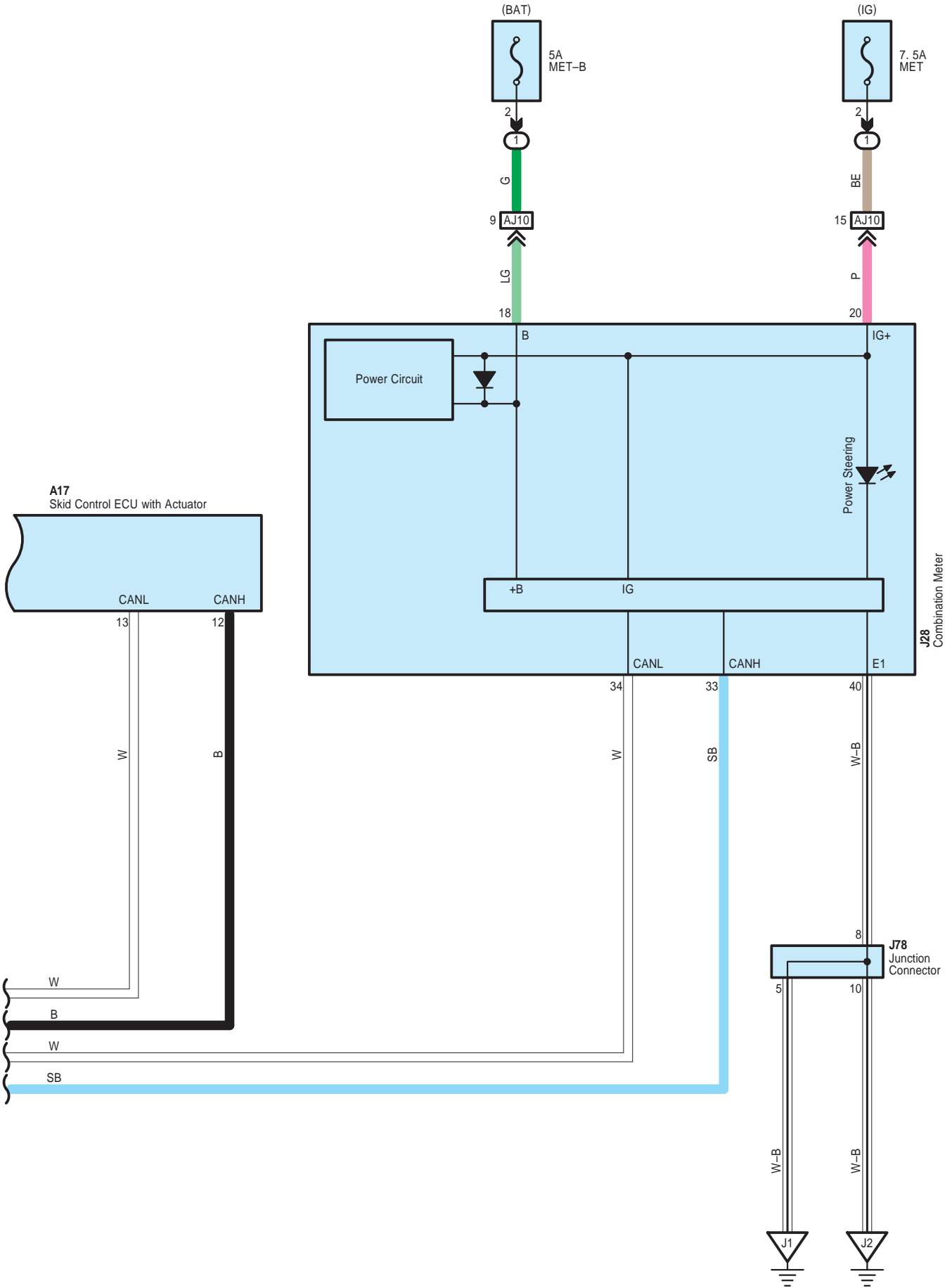

Power Steering

A 17  
Black

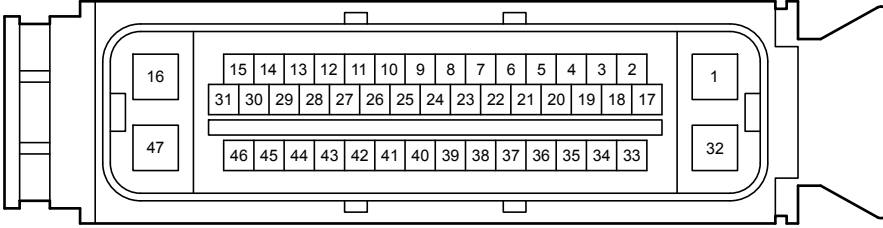

A 24  
Black

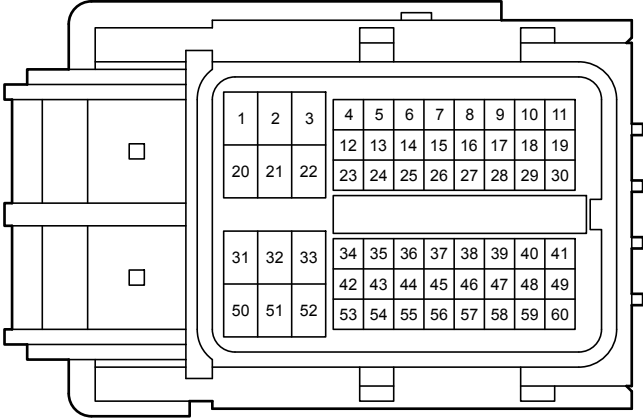

D 3  
Black

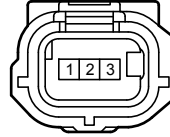

D 74  
Black

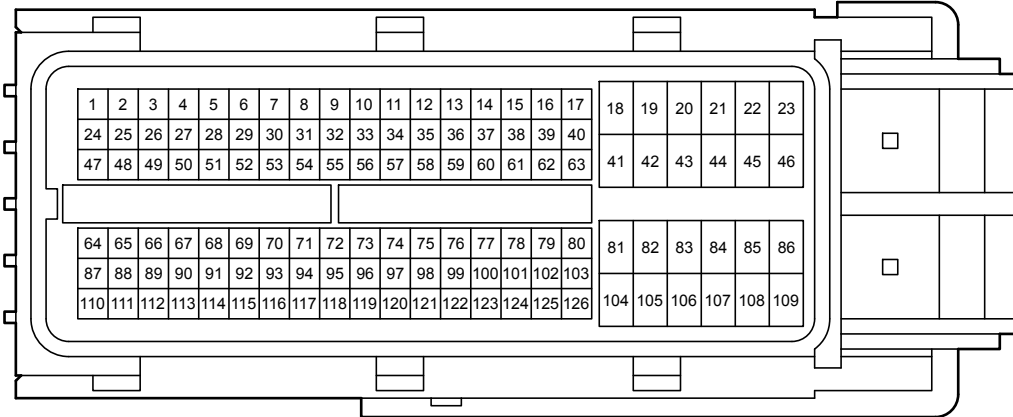

D 84  
Black

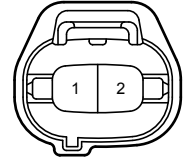

J 6  
Gray

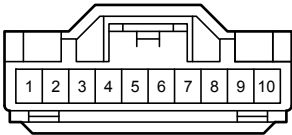

J 28  
White

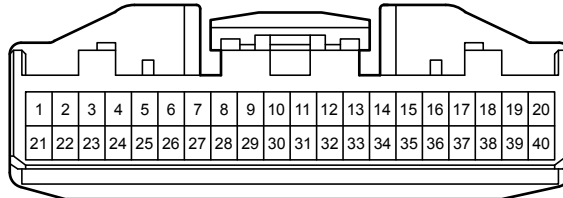

Power Steering

J 71  
Black

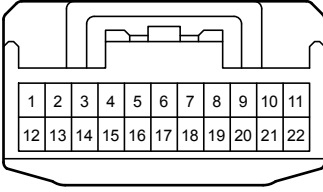

J 72  
Black

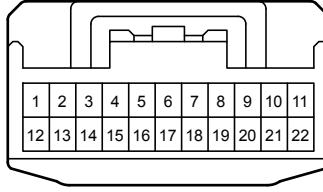

J 73  
Black

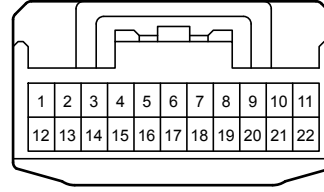

J 74  
Black

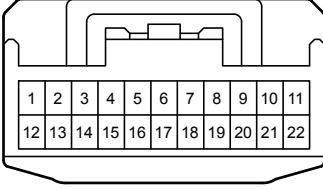

J 77  
Gray

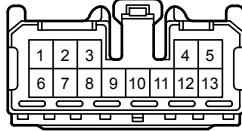

J 78  
White



J113  
Gray

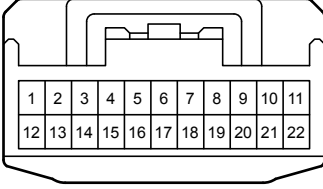

J118  
Gray

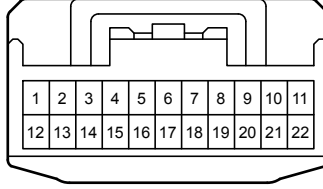

J119  
White

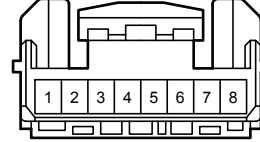

P 15  
Black

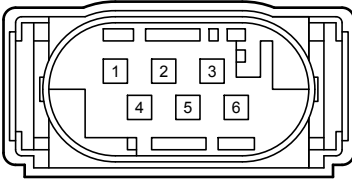

P 16  
Black

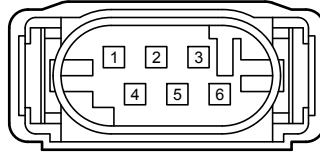

DB  
White

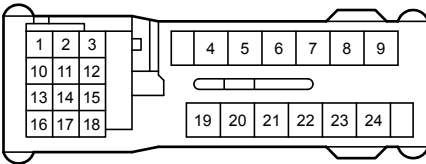

DD  
White

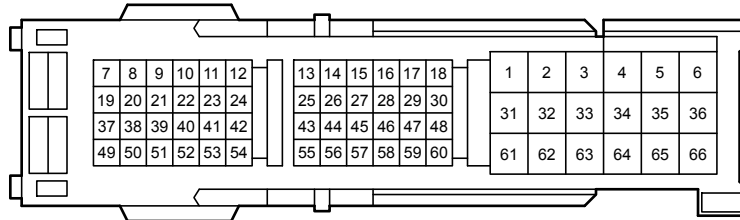

AJ3  
White

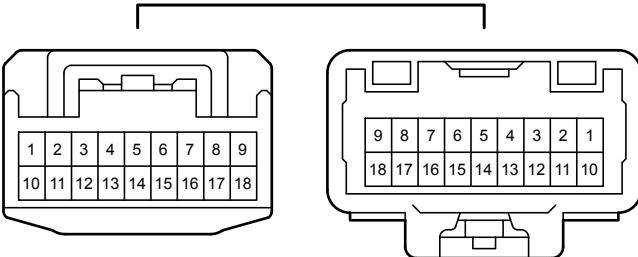

Power Steering

AJ5  
White

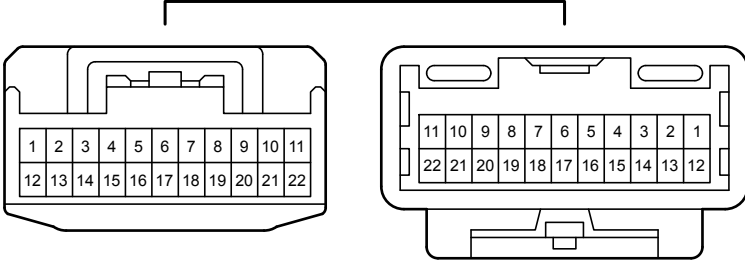

AJ10  
Gray

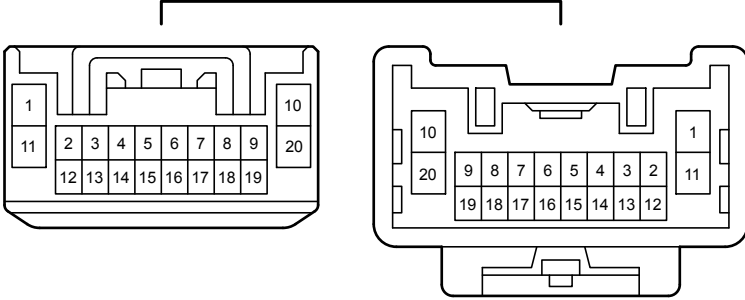

AJ11  
Gray

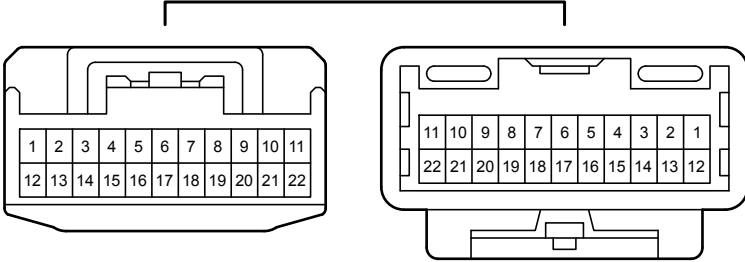

AP1  
White

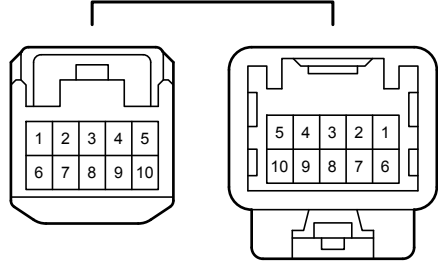

DA1  
White

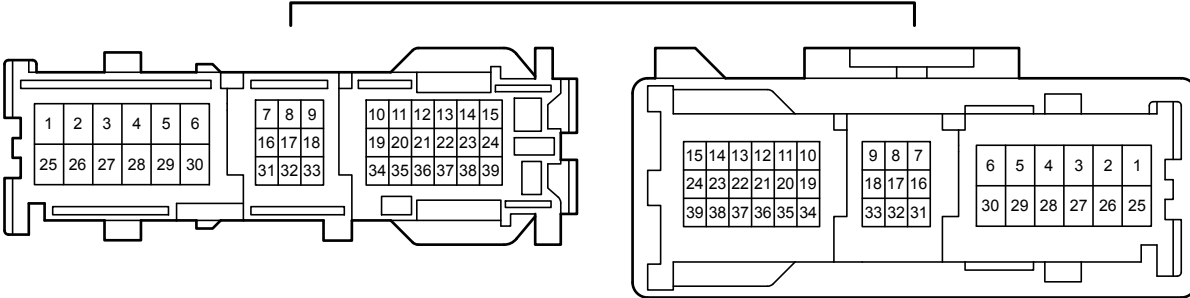

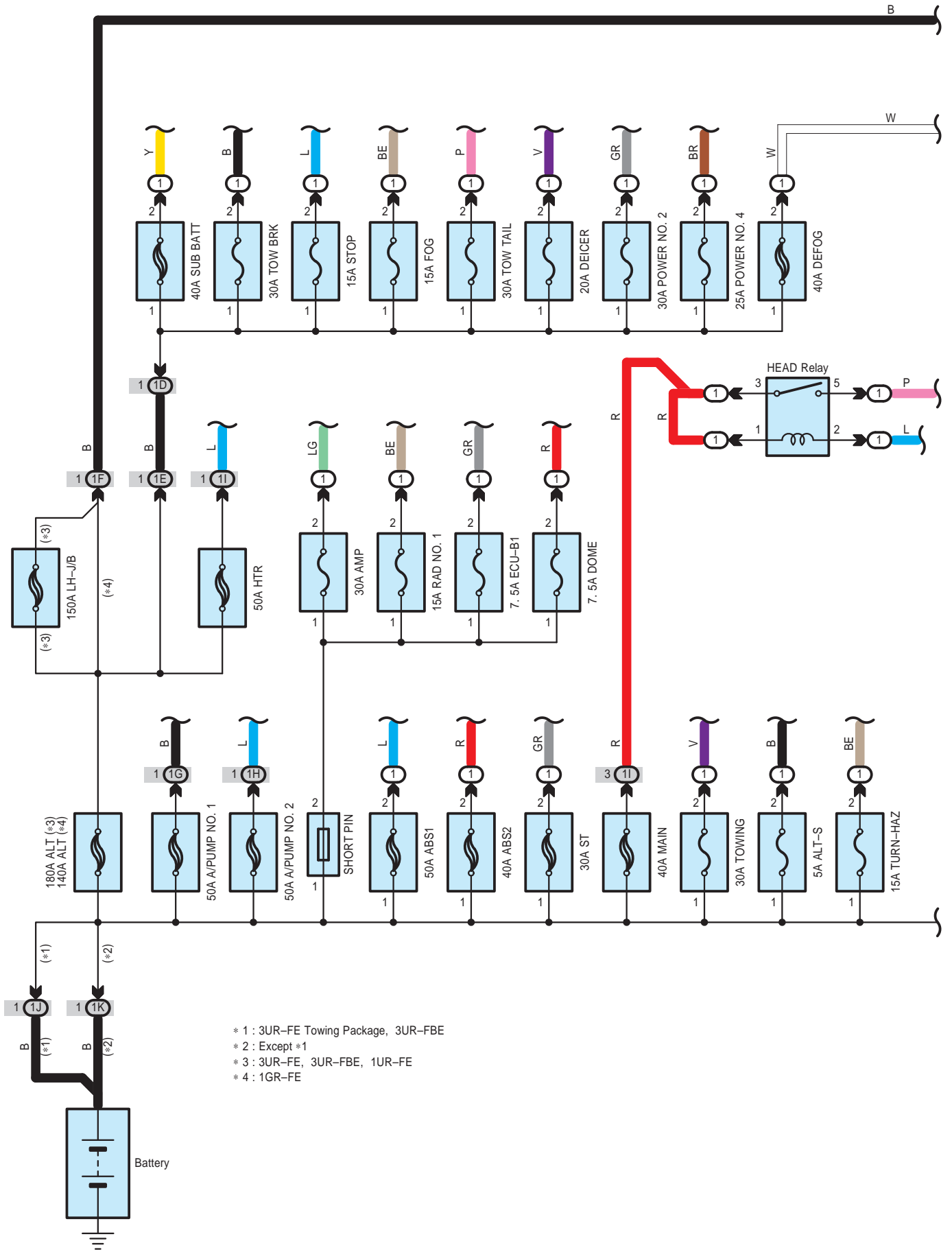

Power Source

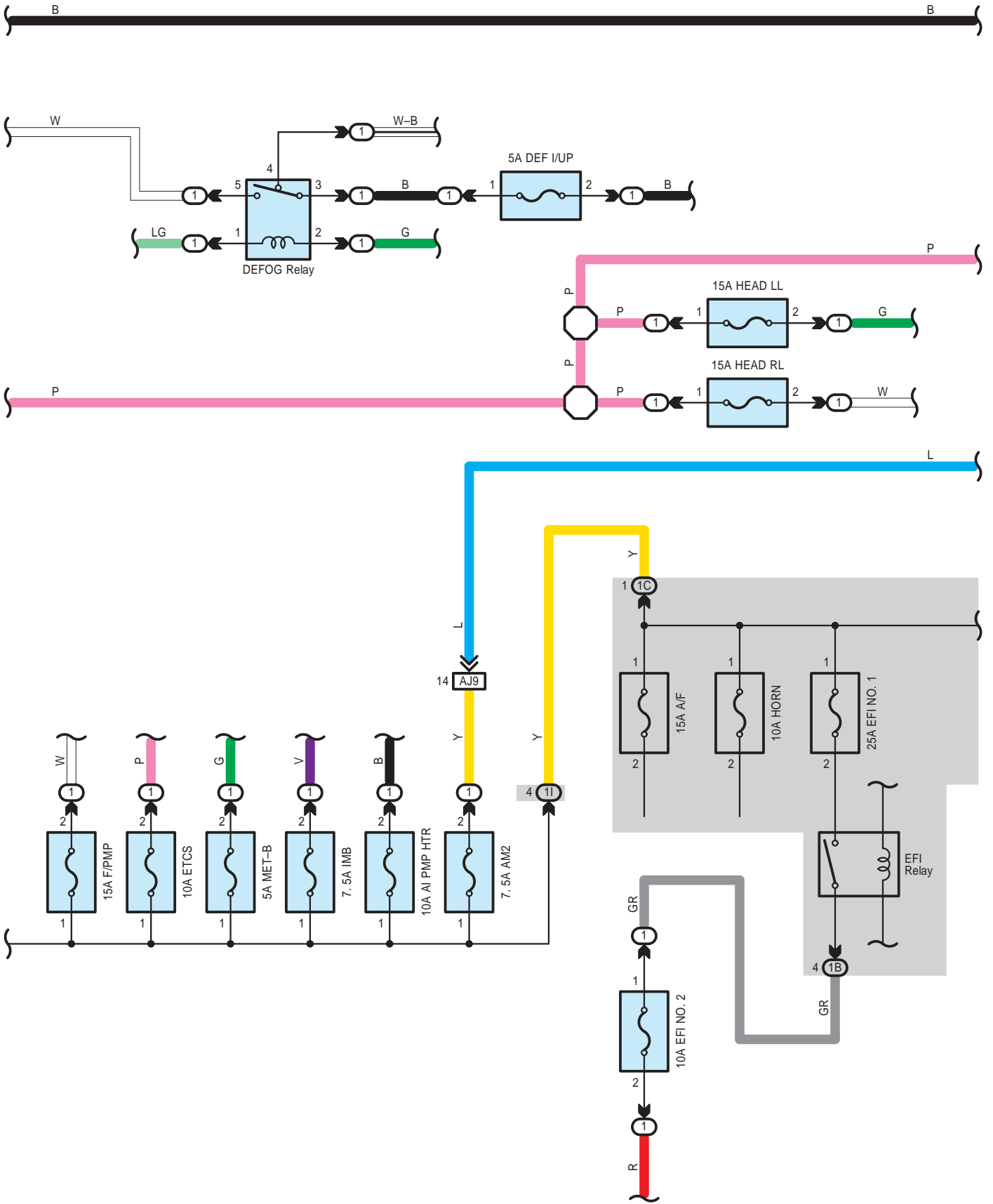

Power Source

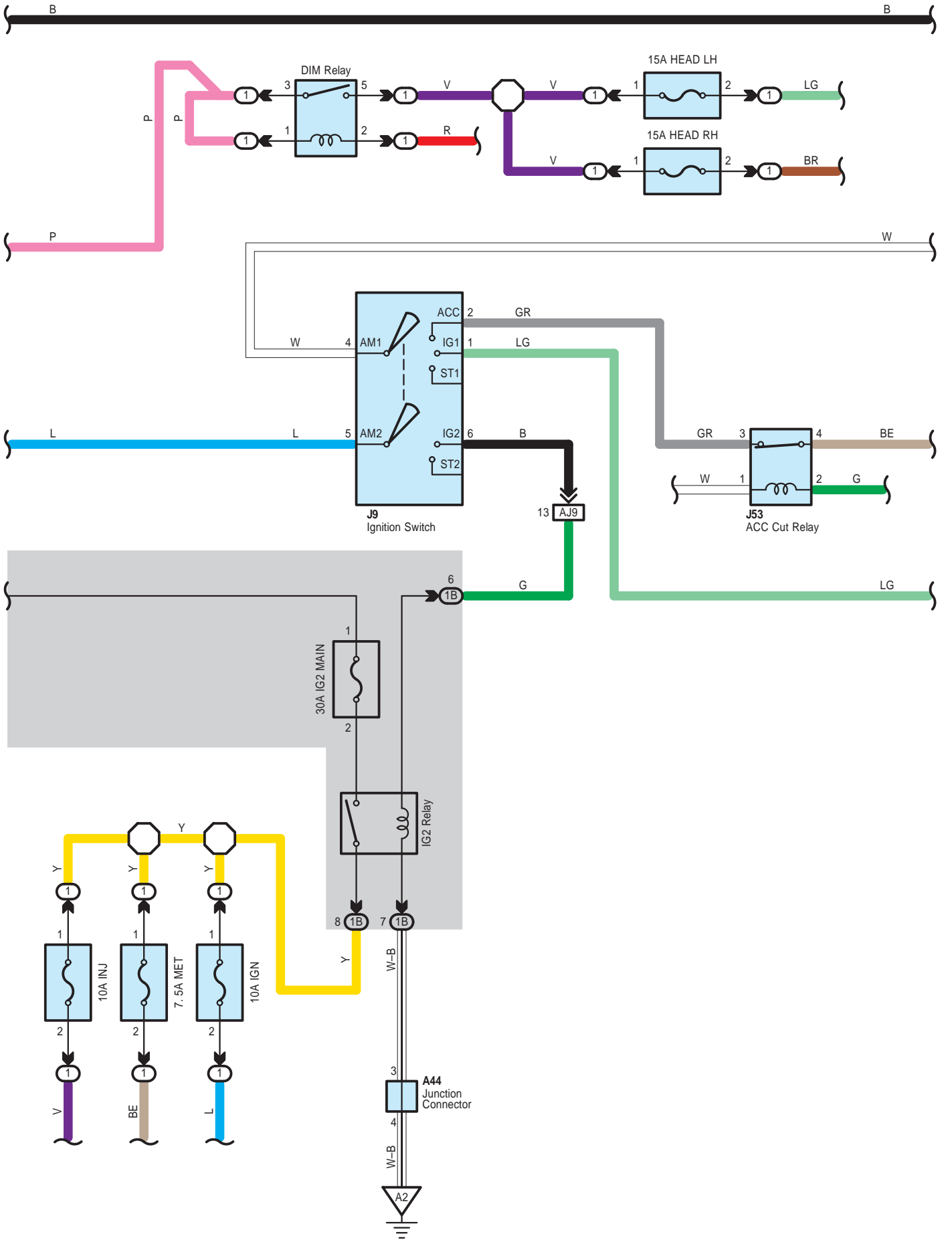

Power Source

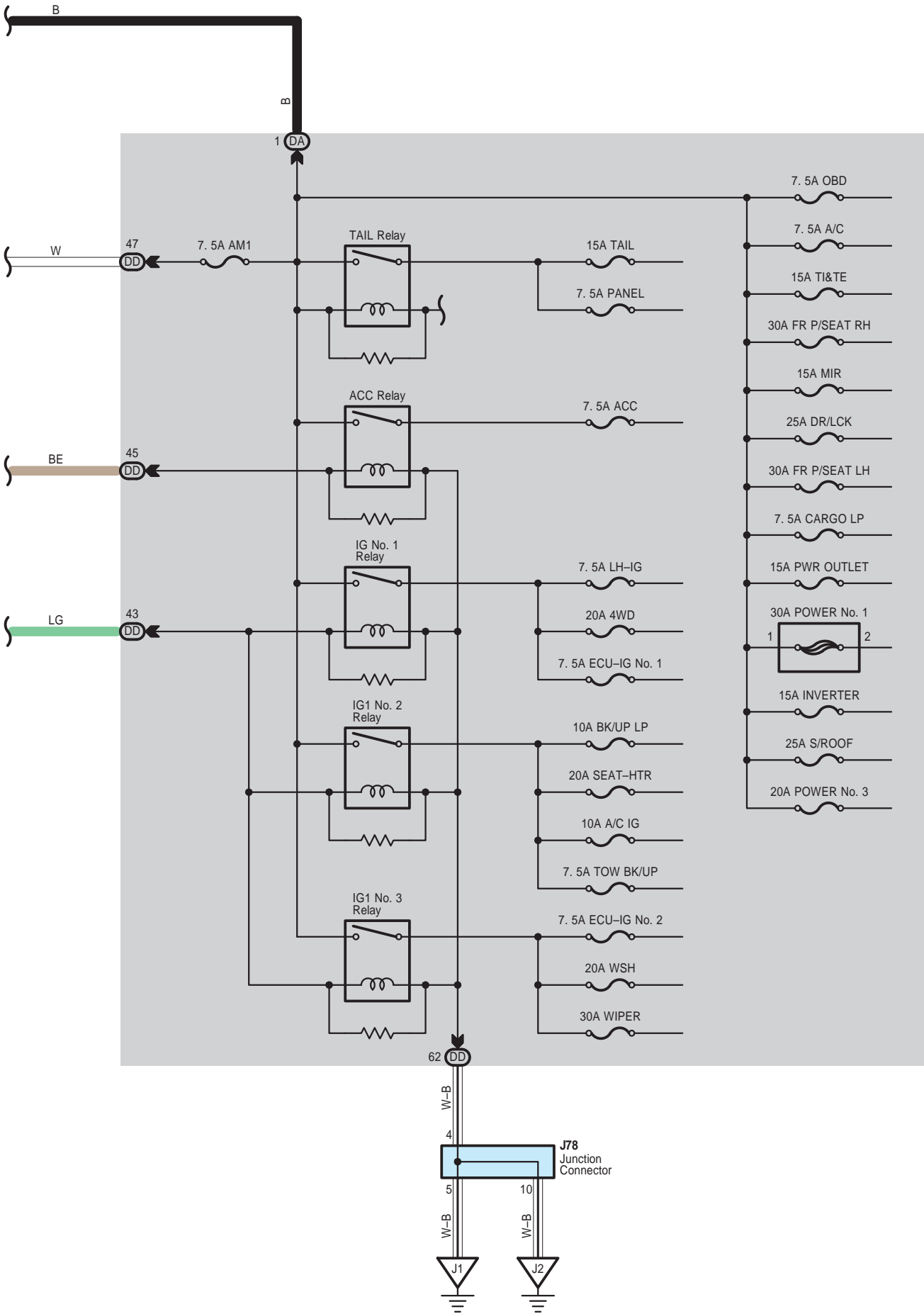



Power Source

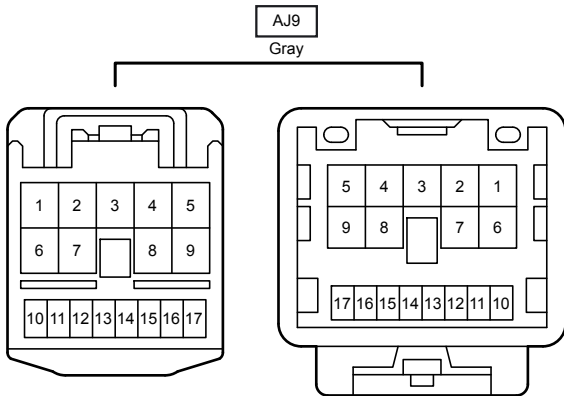
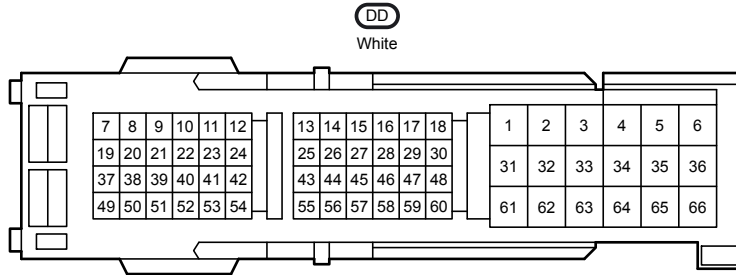
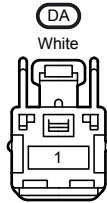
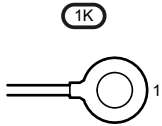
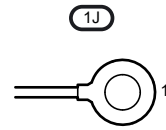
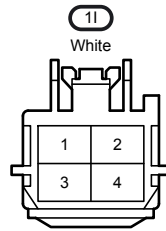
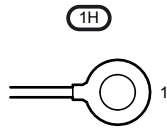
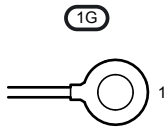
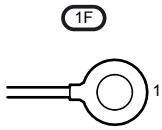
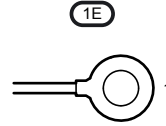
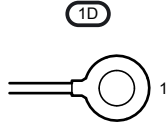
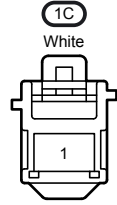
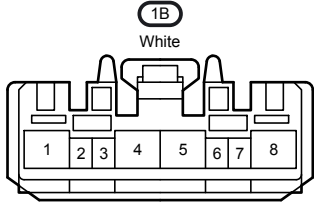
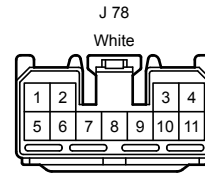
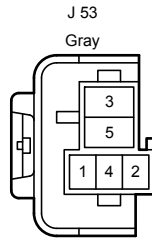
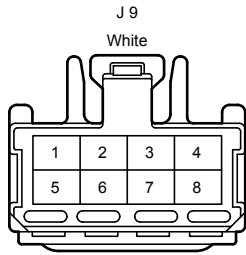
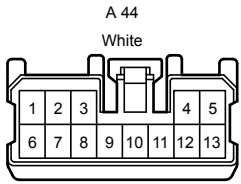

Power Seat <Driver's Seat w/o Seat Position Memory>

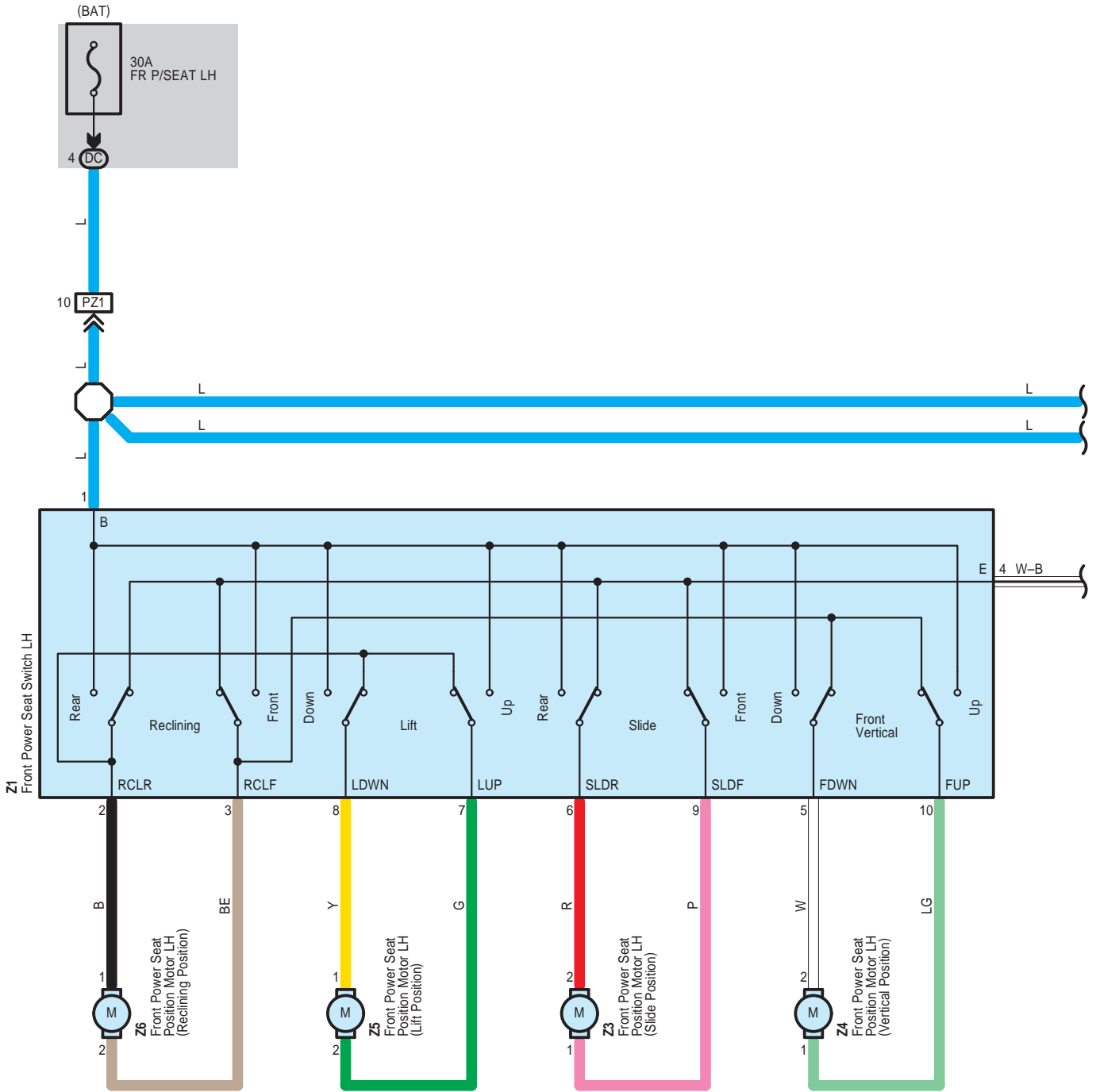

Power Seat <Driver's Seat w/o Seat Position Memory>

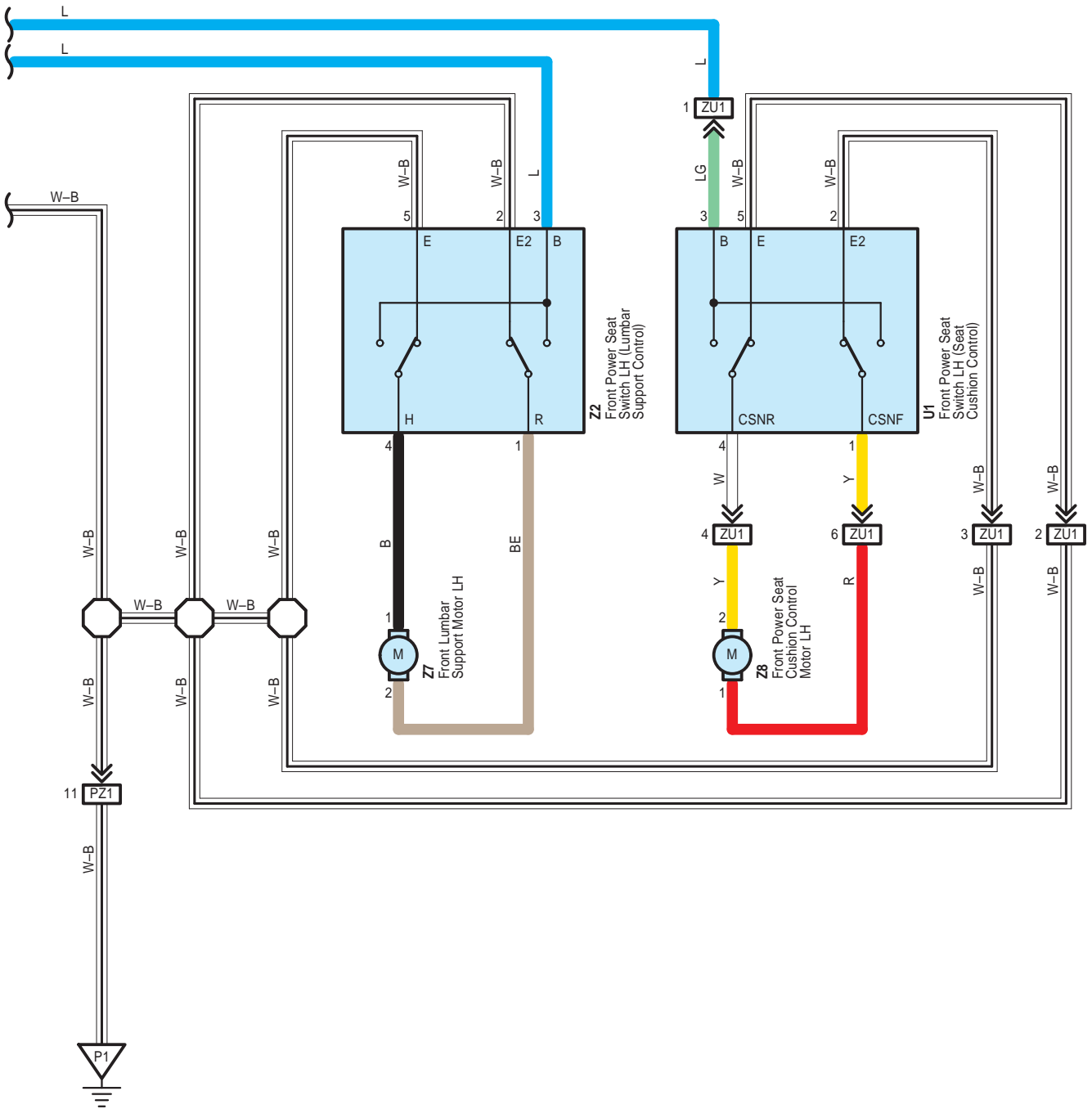

Power Seat <Driver's Seat w/o Seat Position Memory>

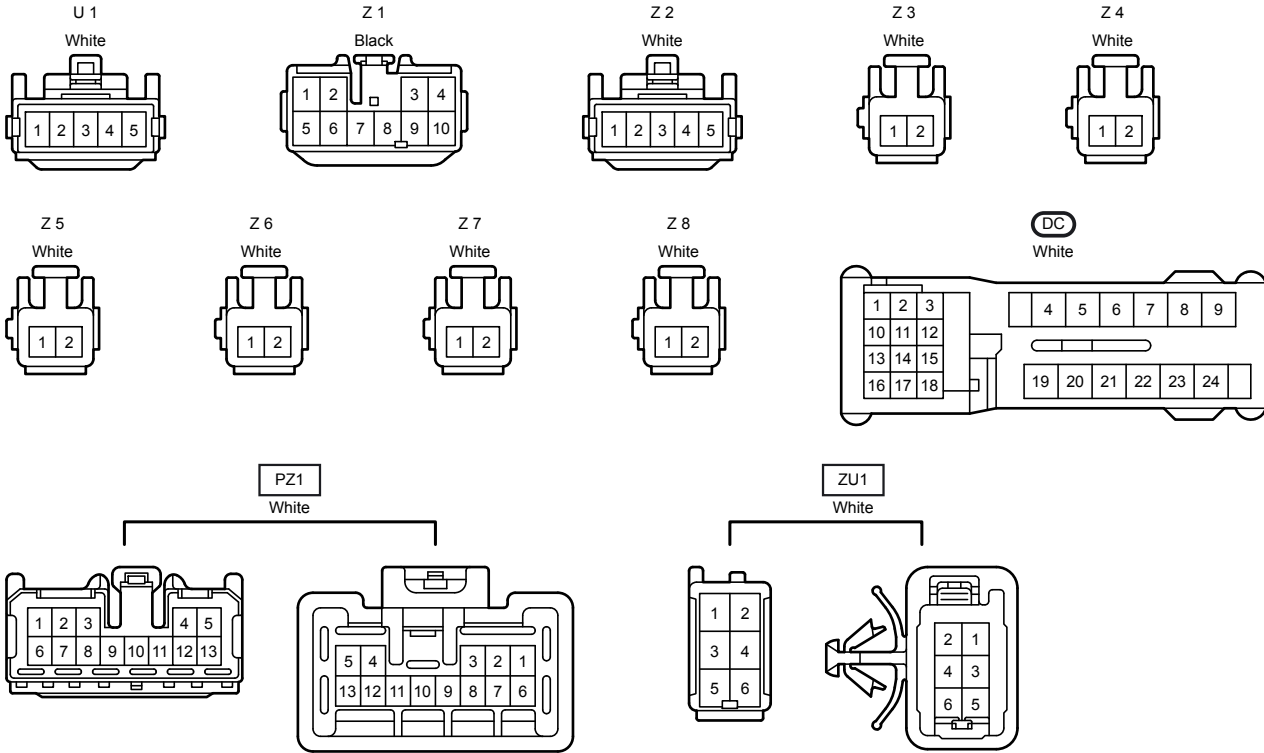

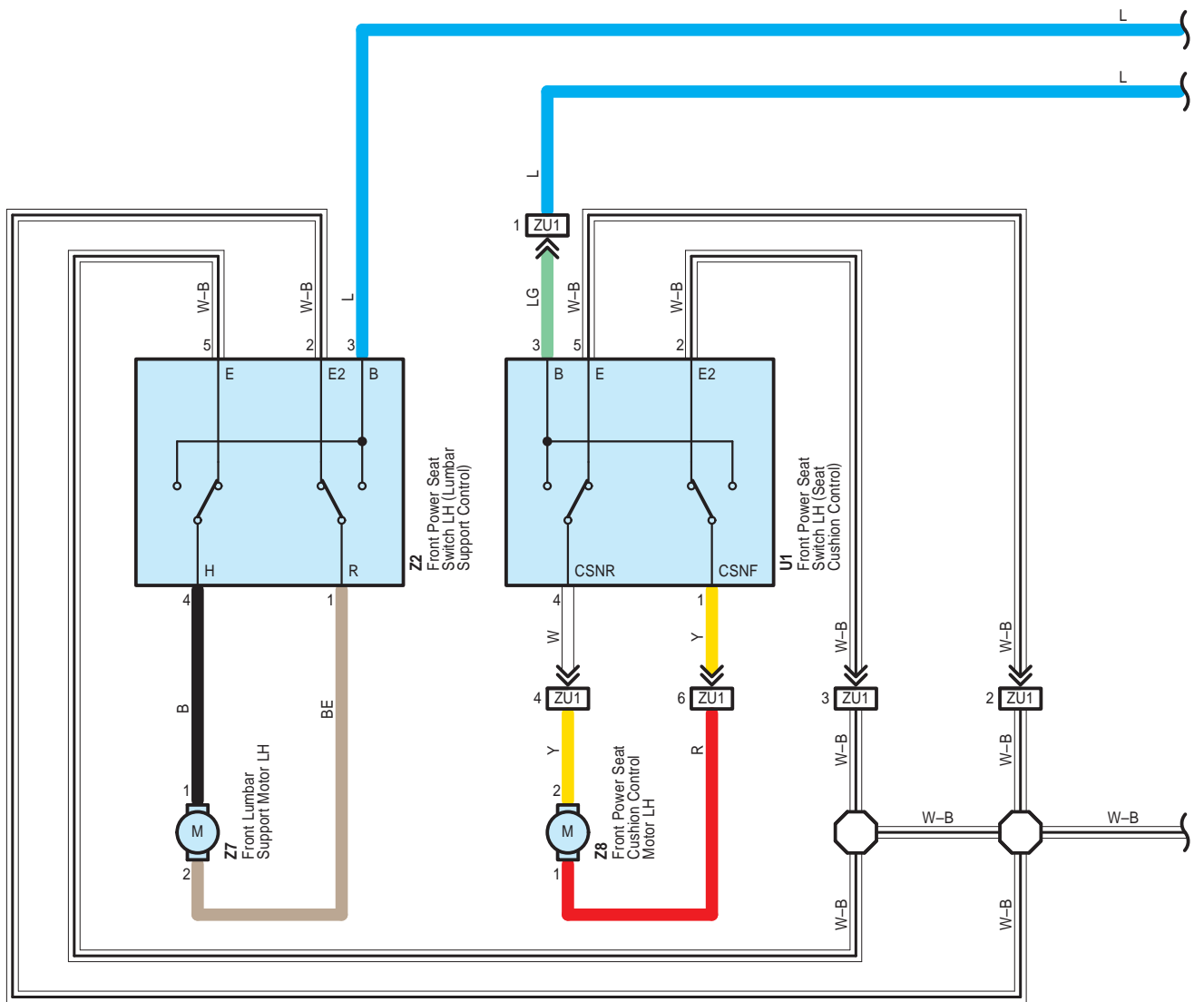

Power Seat <Driver's Seat w/ Seat Position Memory>

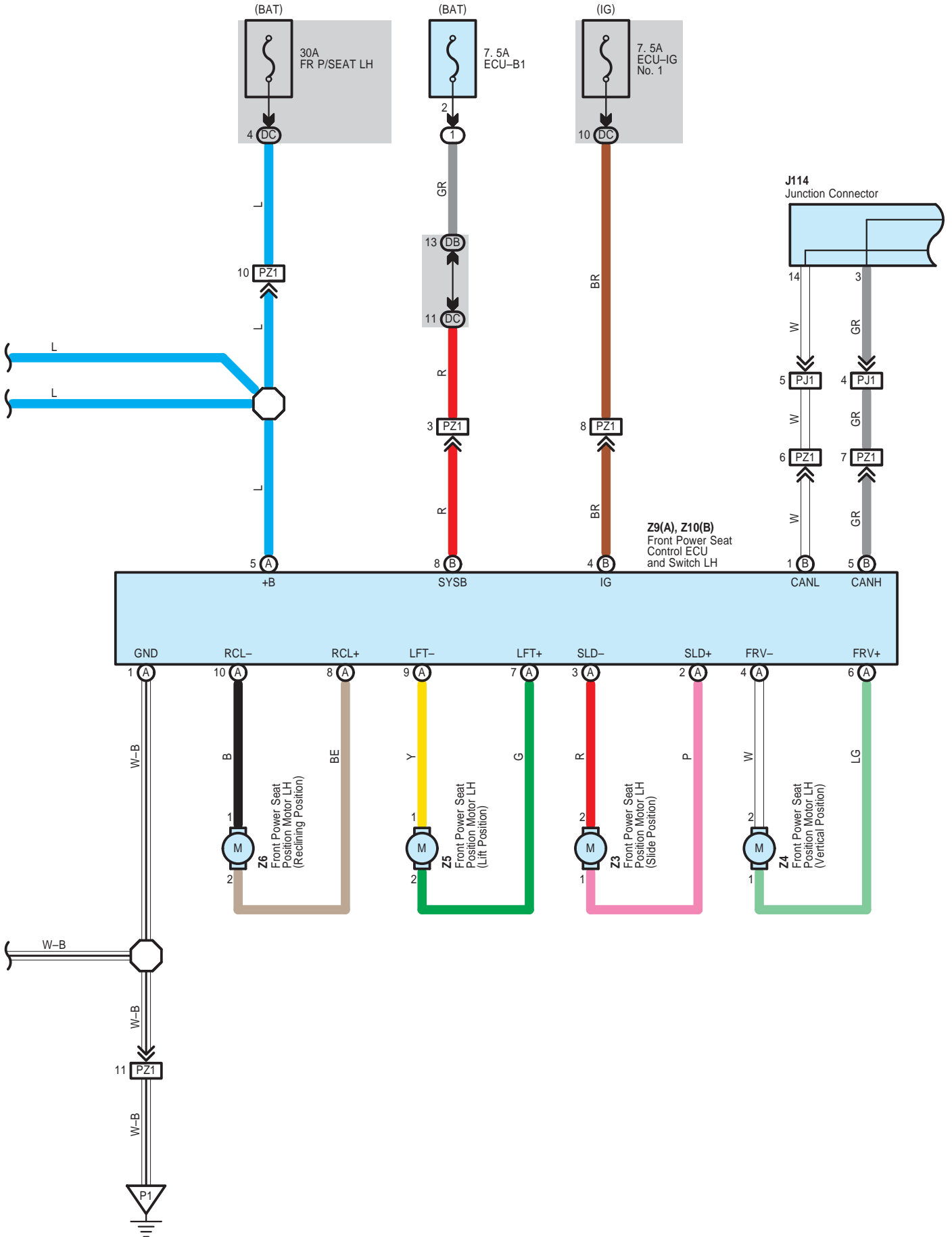

Power Seat <Driver's Seat w/ Seat Position Memory>

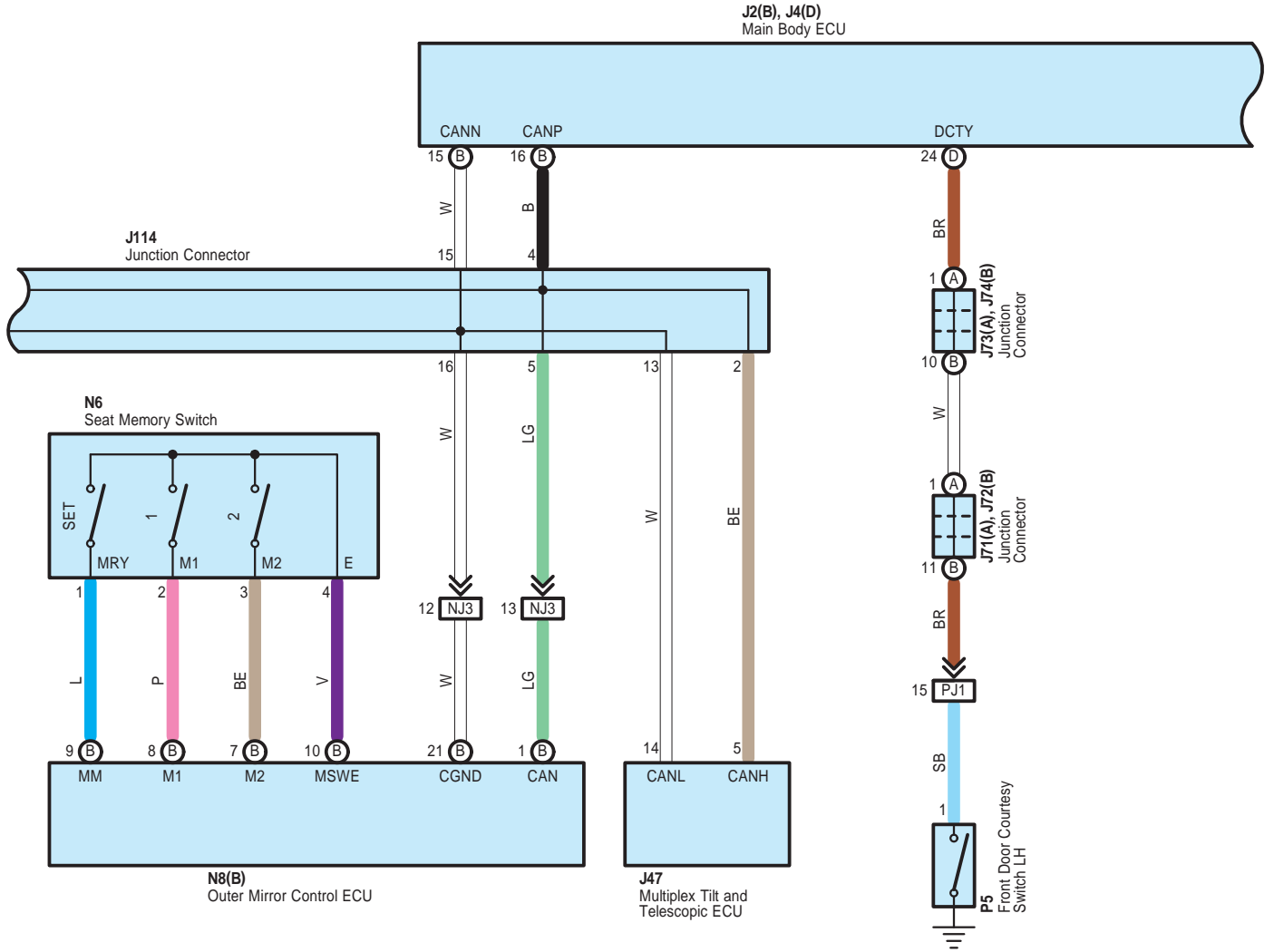

Power Seat <Driver's Seat w/ Seat Position Memory>

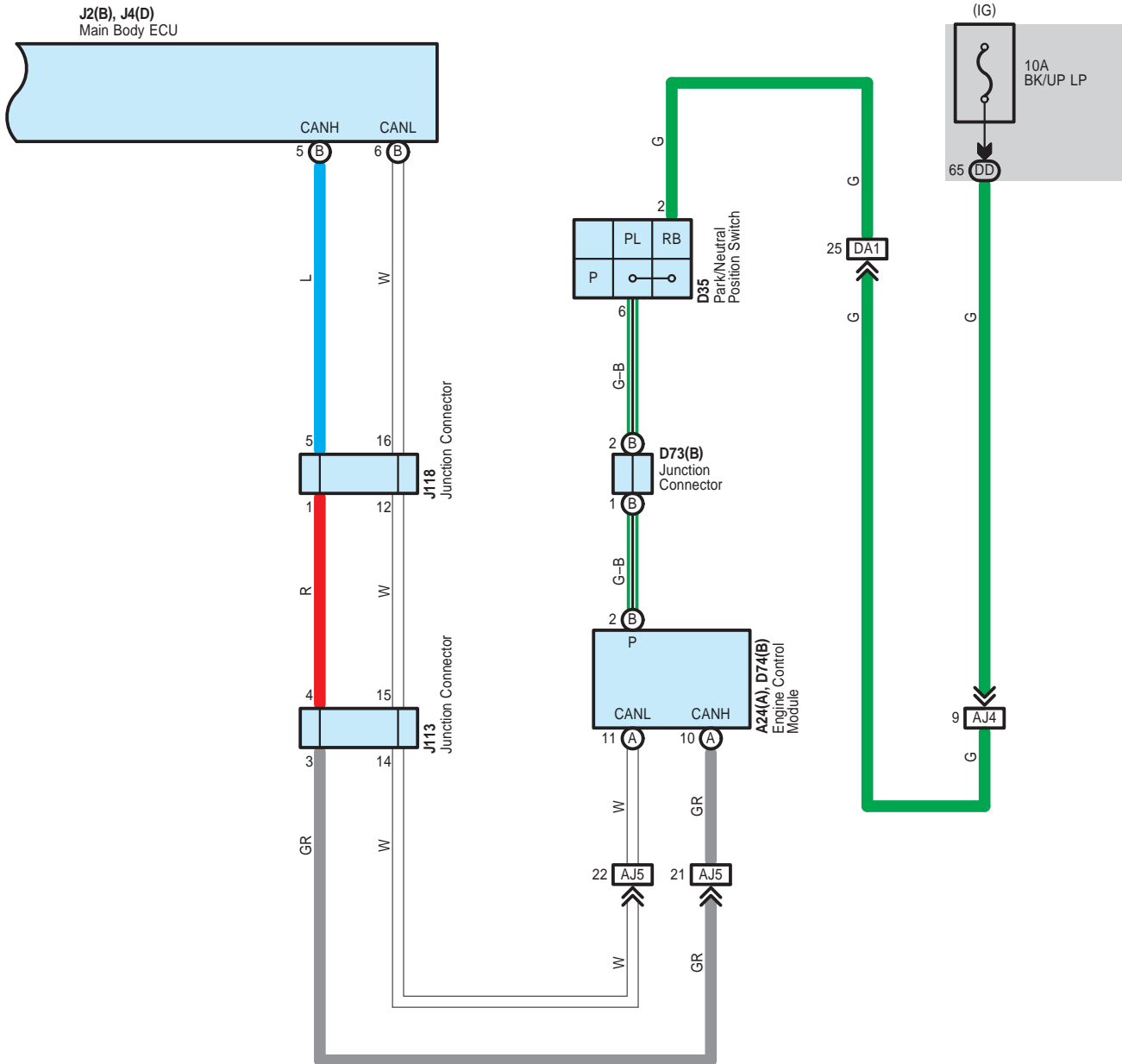



Power Seat <Driver's Seat w/ Seat Position Memory>

A 24  
Black

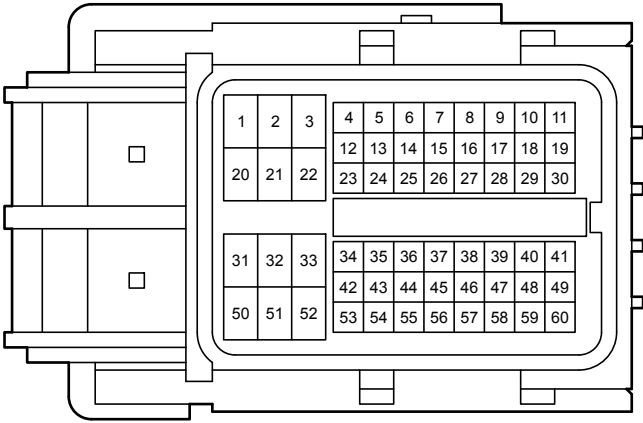

D 35  
Gray

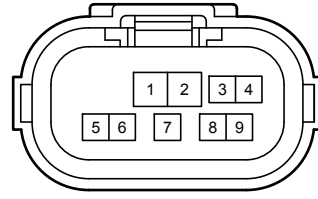

D 73  
Blue

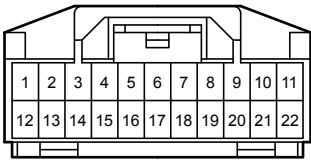

D 74  
Black

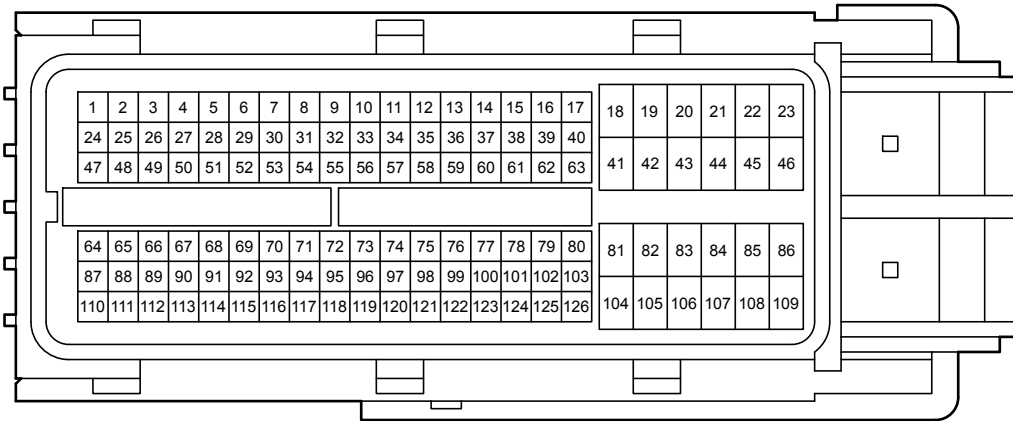

J 2  
White

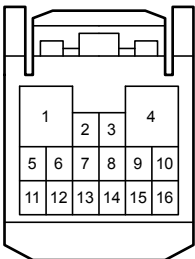

J 4  
White

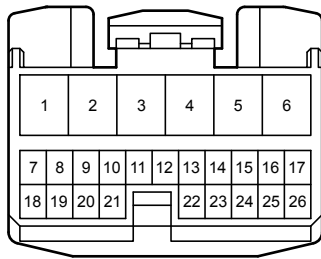

J 47  
White

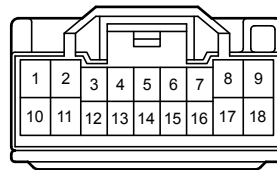

Power Seat <Driver's Seat w/ Seat Position Memory>

J 71  
Black

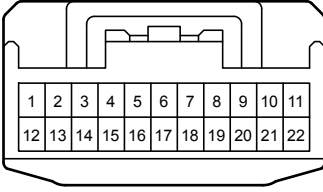

J 72  
Black

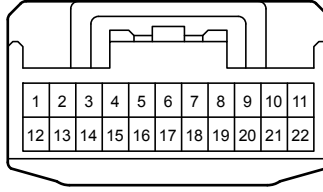

J 73  
Black

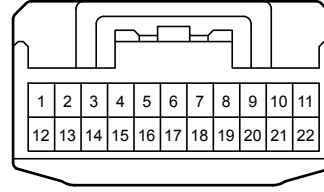

J 74  
Black

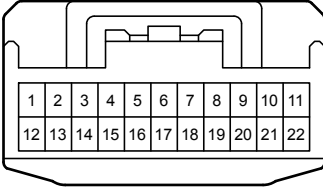

J113  
Gray

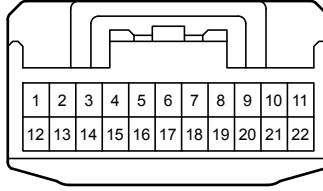

J114  
Gray

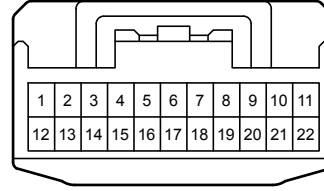

J118  
Gray

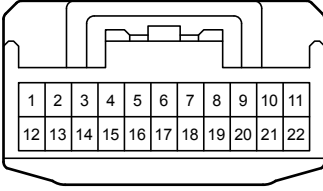

N 6  
White

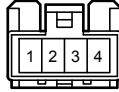

N 8  
White

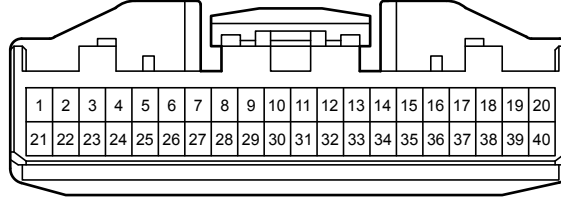

P 5  
White



U 1  
White

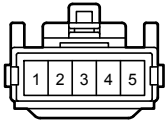

Z 2  
White

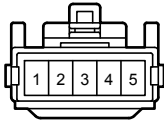

Z 3  
White

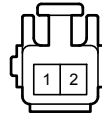

Z 4  
White

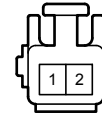

Z 5  
White

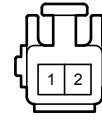

Z 6  
White

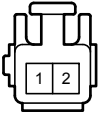

Z 7  
White

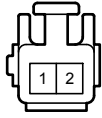

Z 8  
White

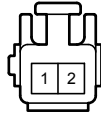

Z 9  
White

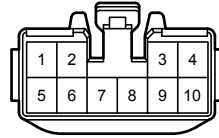

Z 10  
White

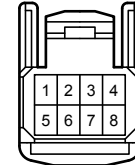

DB  
White

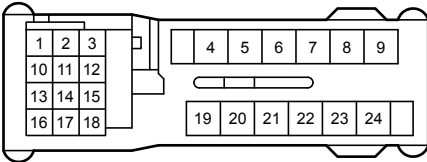

DC  
White

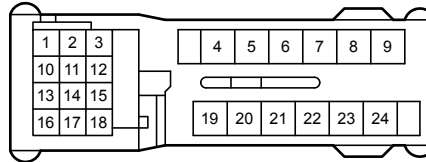

DD  
White

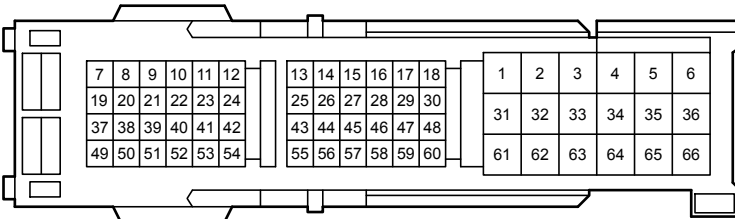

Power Seat <Driver's Seat w/ Seat Position Memory>

AJ4  
White

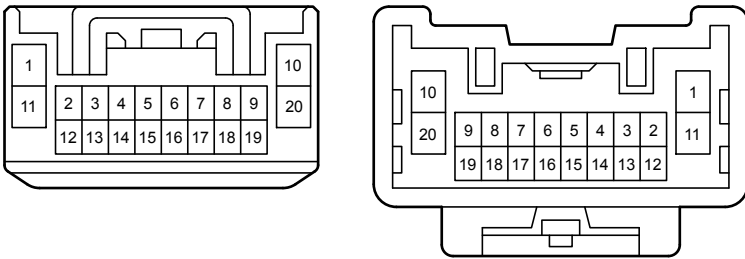

AJ5  
White

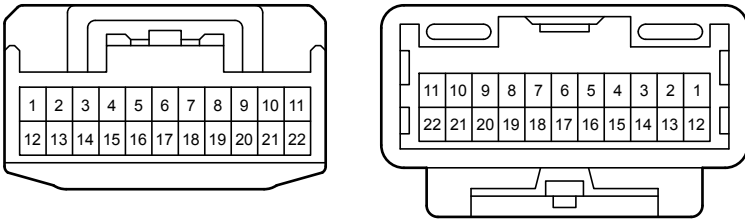

DA1  
White

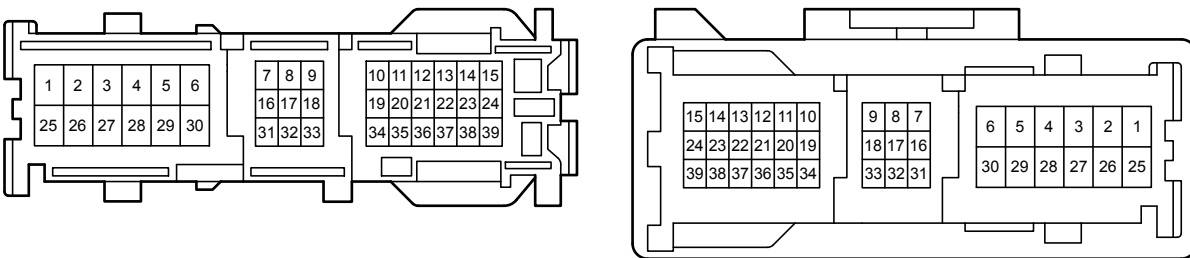

NJ3  
Blue

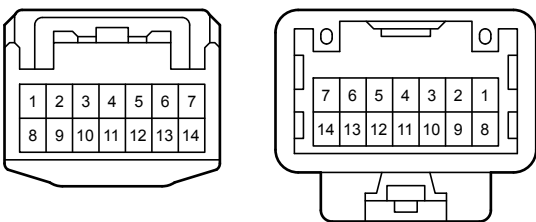

PJ1  
Black

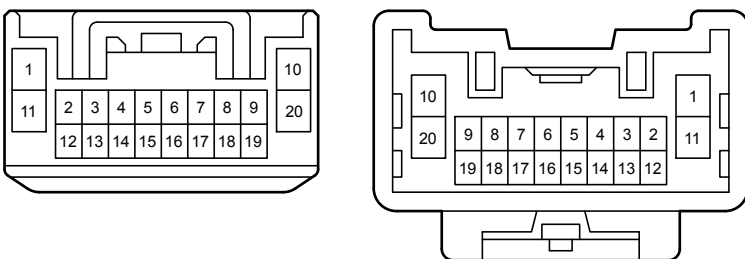

Power Seat <Driver's Seat w/ Seat Position Memory>

PZ1  
White

ZU1  
White

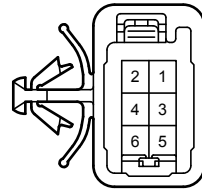
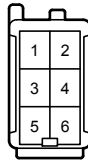
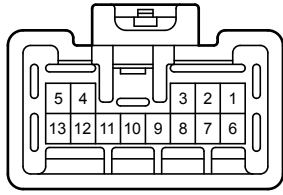
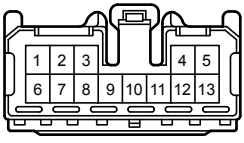

Power Seat <Front Passenger's Seat>

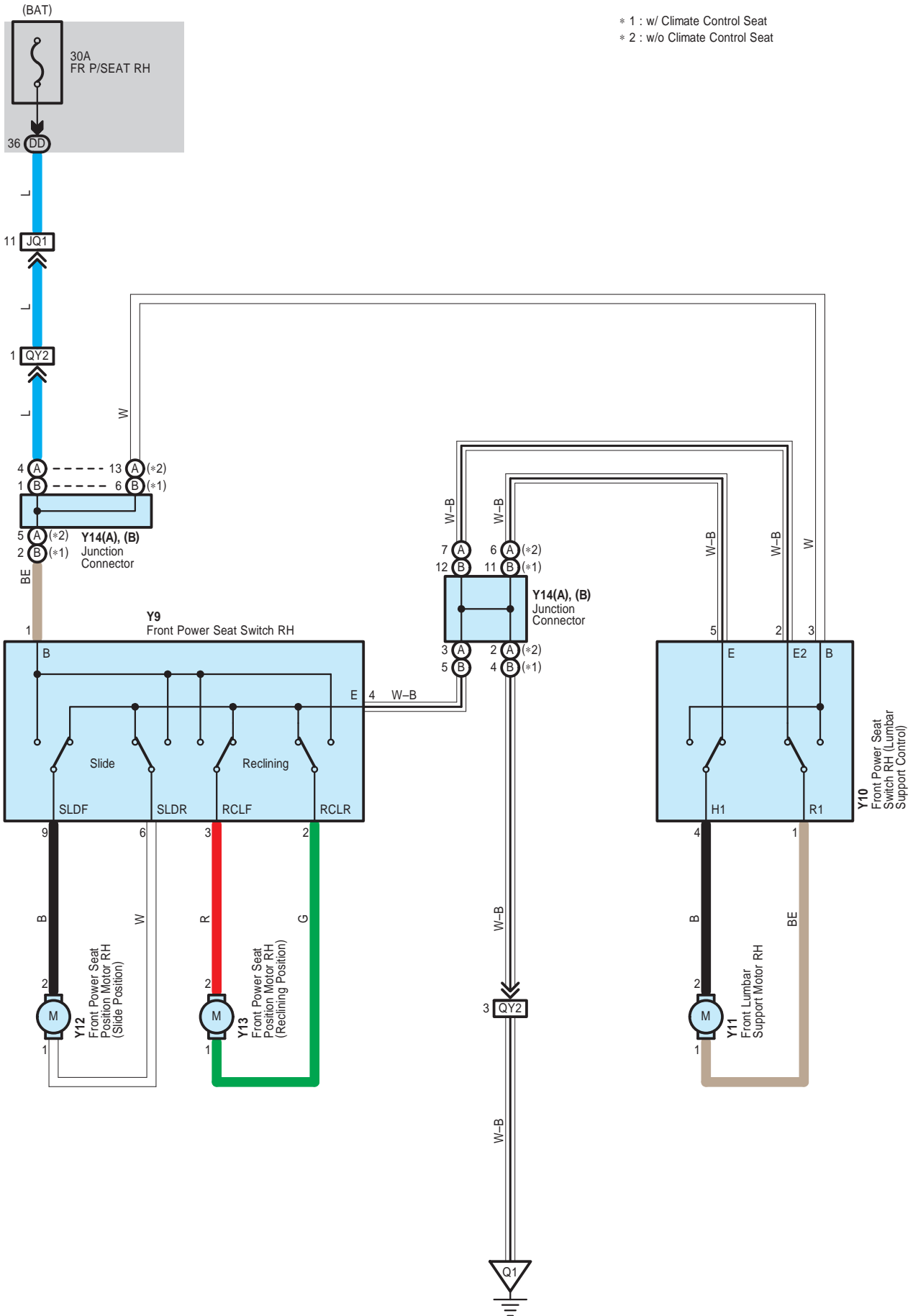

\* 1 : w/ Climate Control Seat  
\* 2 : w/o Climate Control Seat

Power Seat <Front Passenger's Seat>

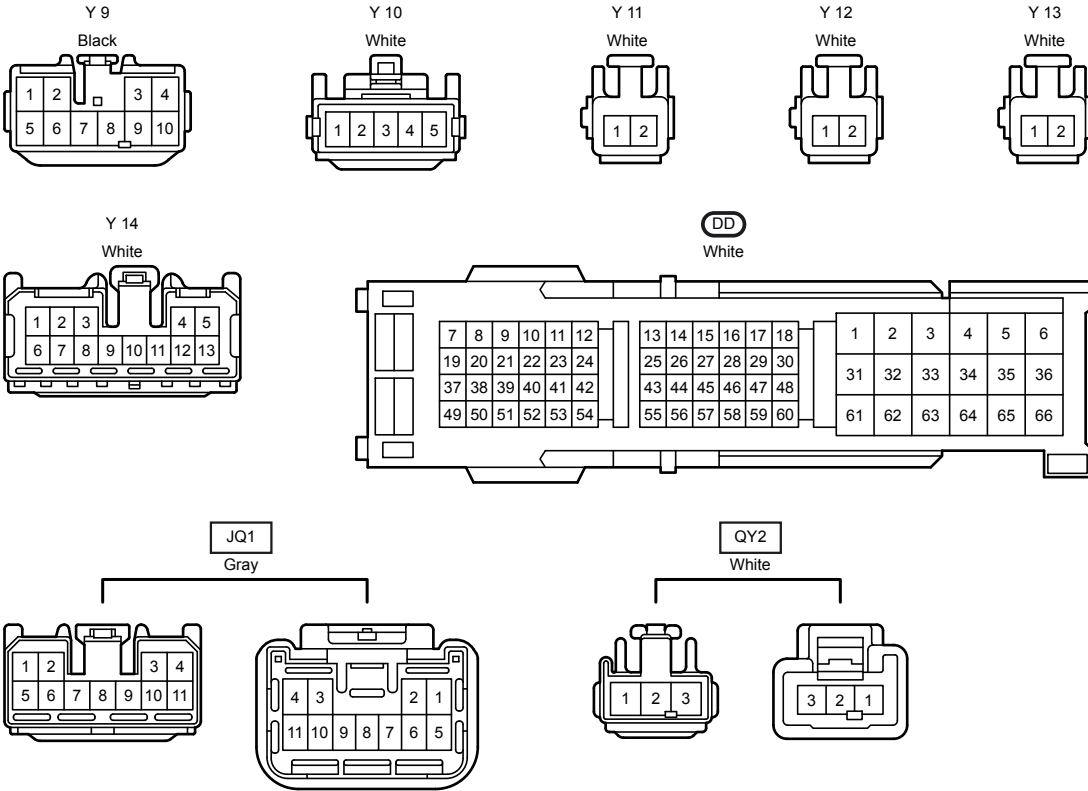

Power Tilt and Power Telescopic

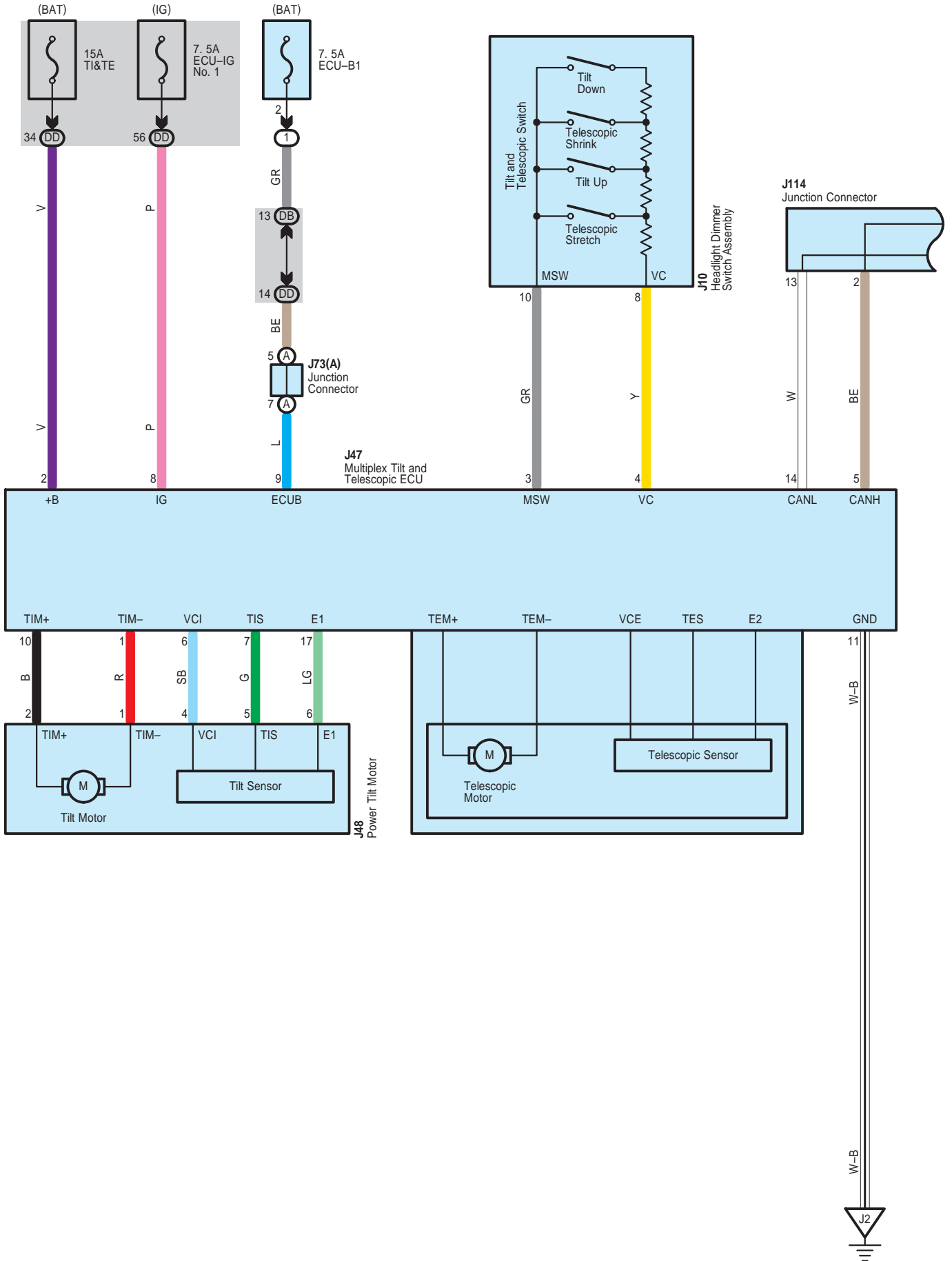

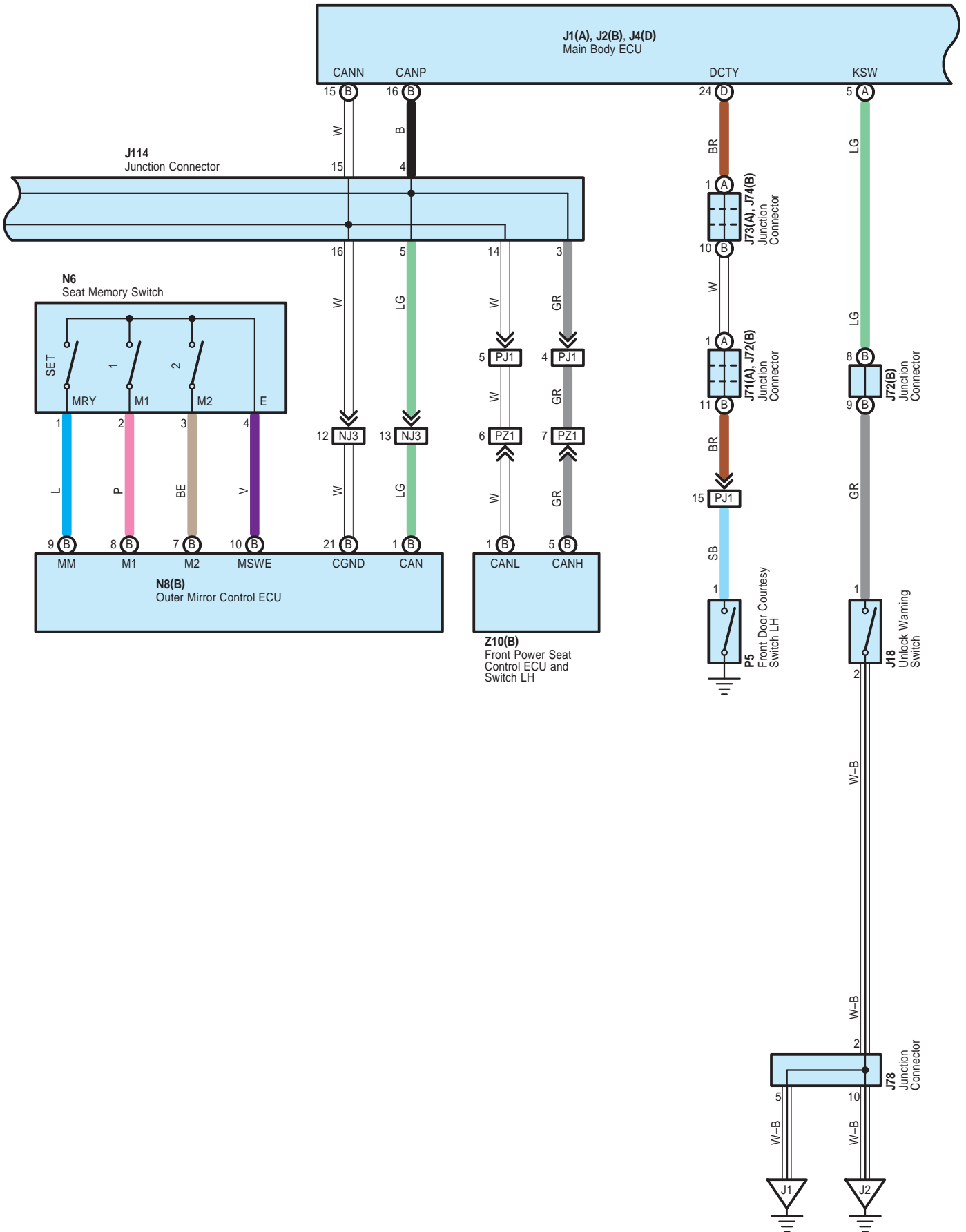



Power Tilt and Power Telescopic

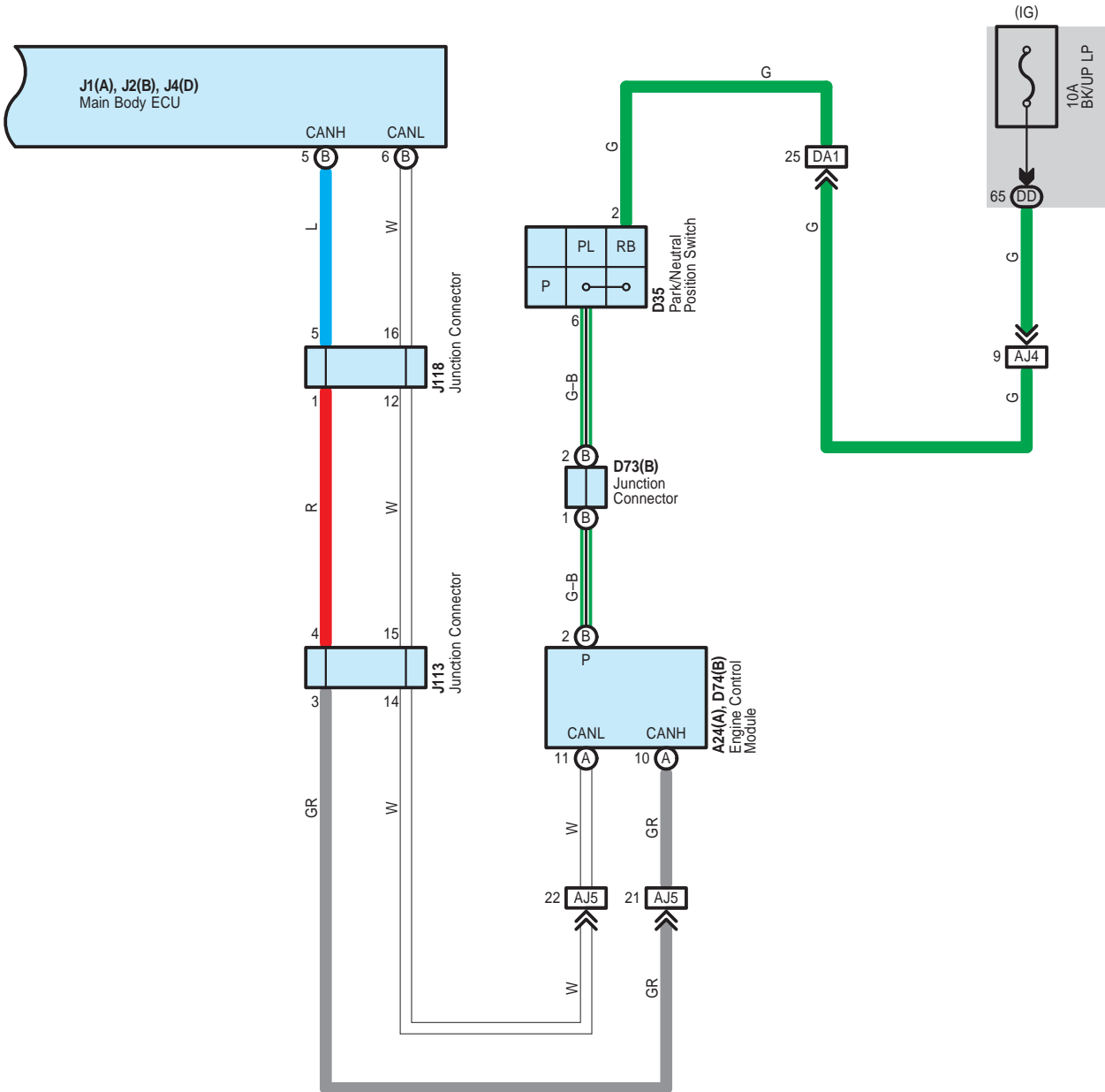

Power Tilt and Power Telescopic

A 24  
Black

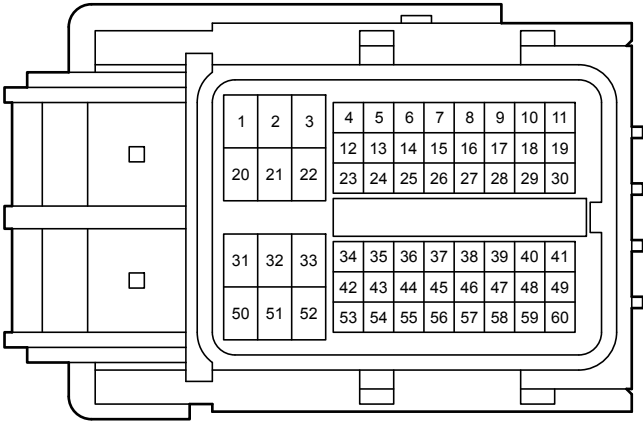

D 35  
Gray

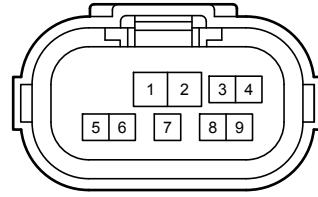

D 73  
Blue

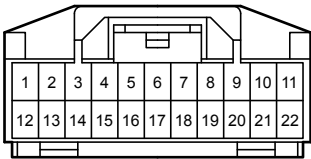

D 74  
Black

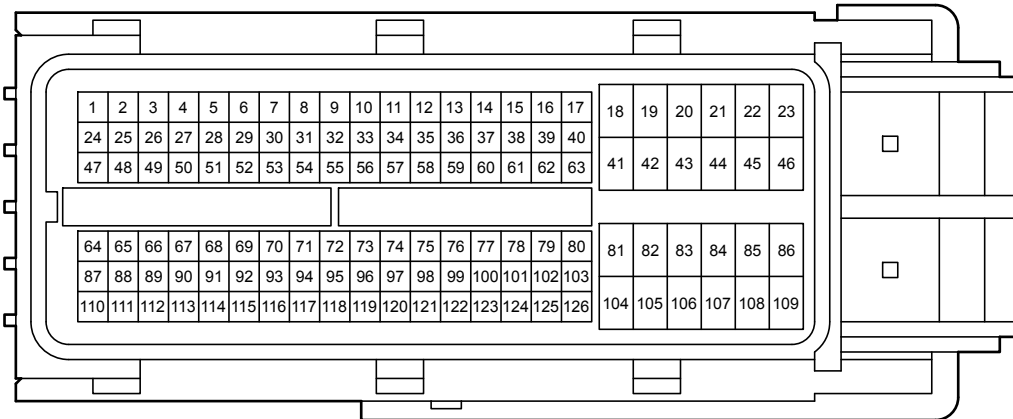

J 1  
White

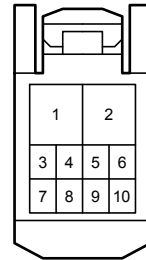

J 2  
White

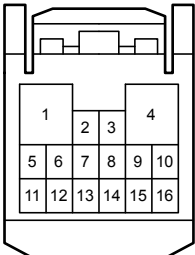

J 4  
White

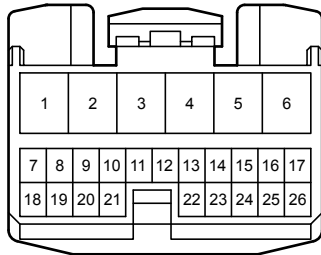

J 10  
White

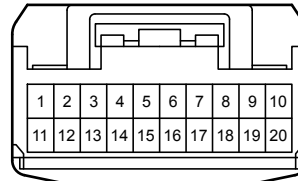

J 18  
White





AJ4  
White

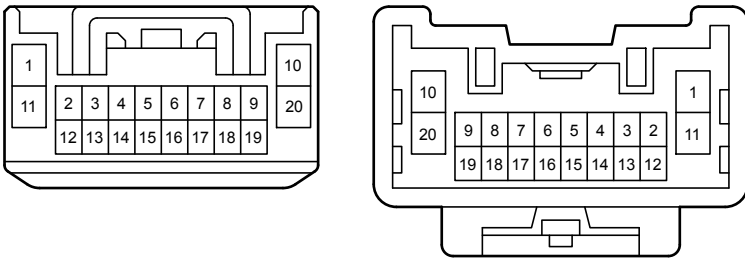

AJ5  
White

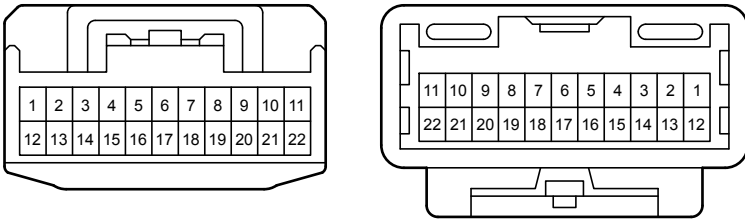

DA1  
White

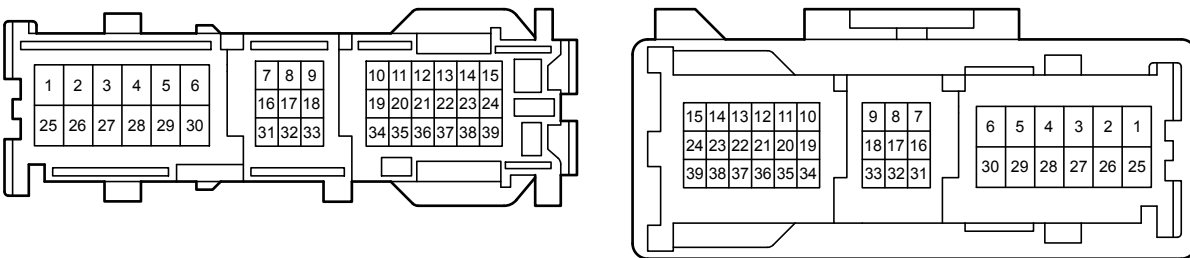

NJ3  
Blue

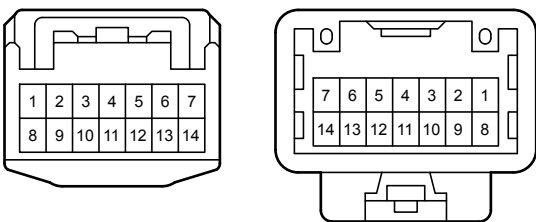

PJ1  
Black

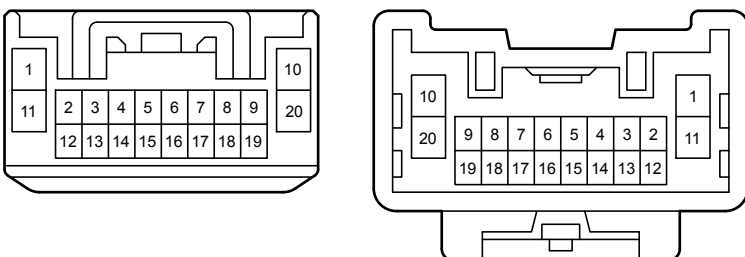

PZ1  
White

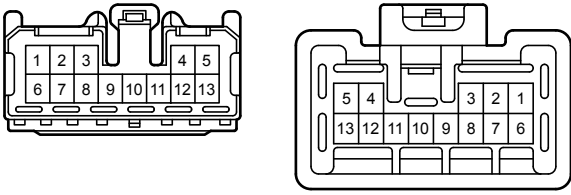

Power Window

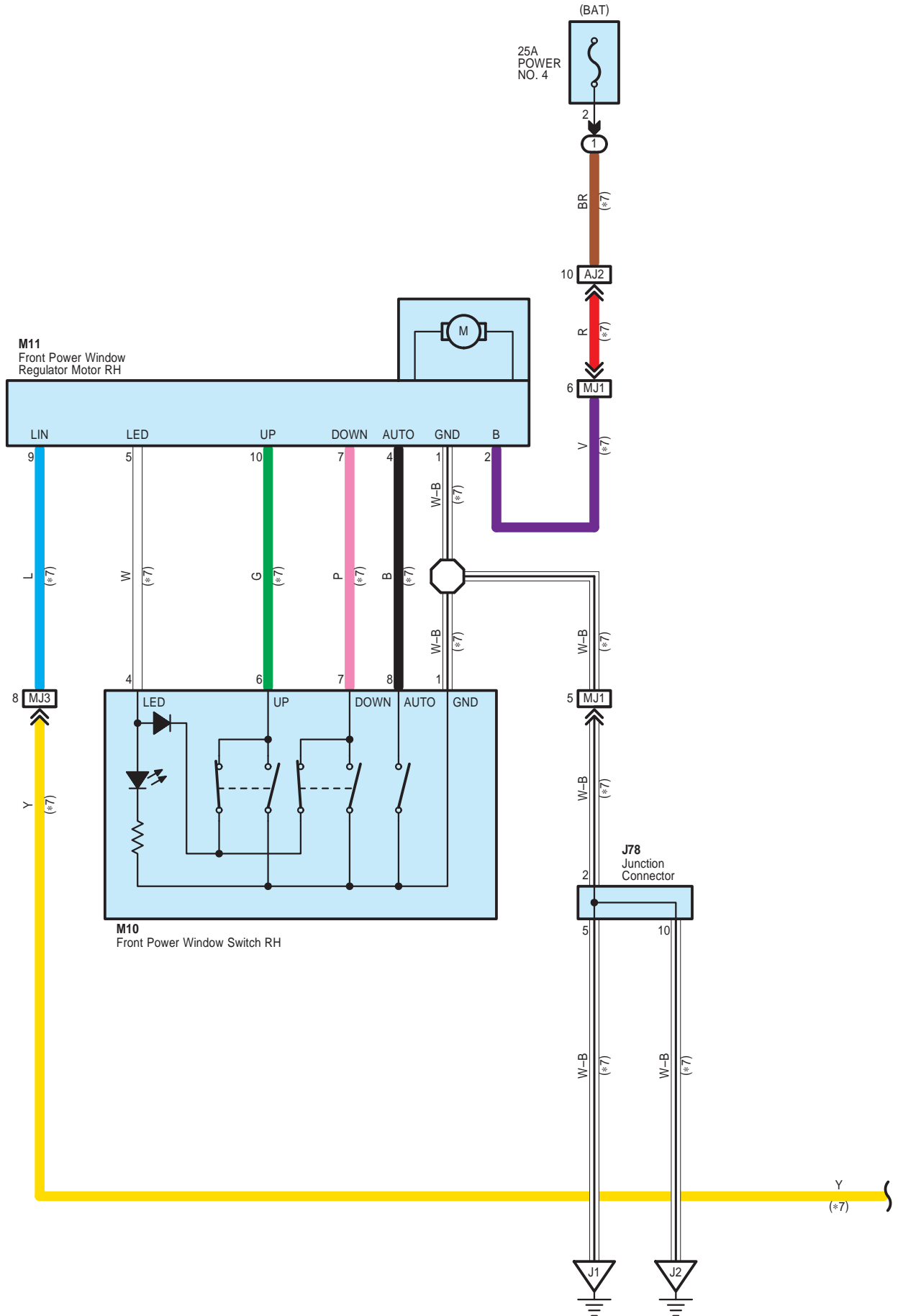



Power Window

- \* 1 : Except Regular Cab
- \* 2 : Regular Cab
- \* 3 : Double Cab
- \* 4 : CrewMax
- \* 7 : w/ Auto Up
- \* 8 : w/o Auto Up
- \* 9 : w/ Back Power Window

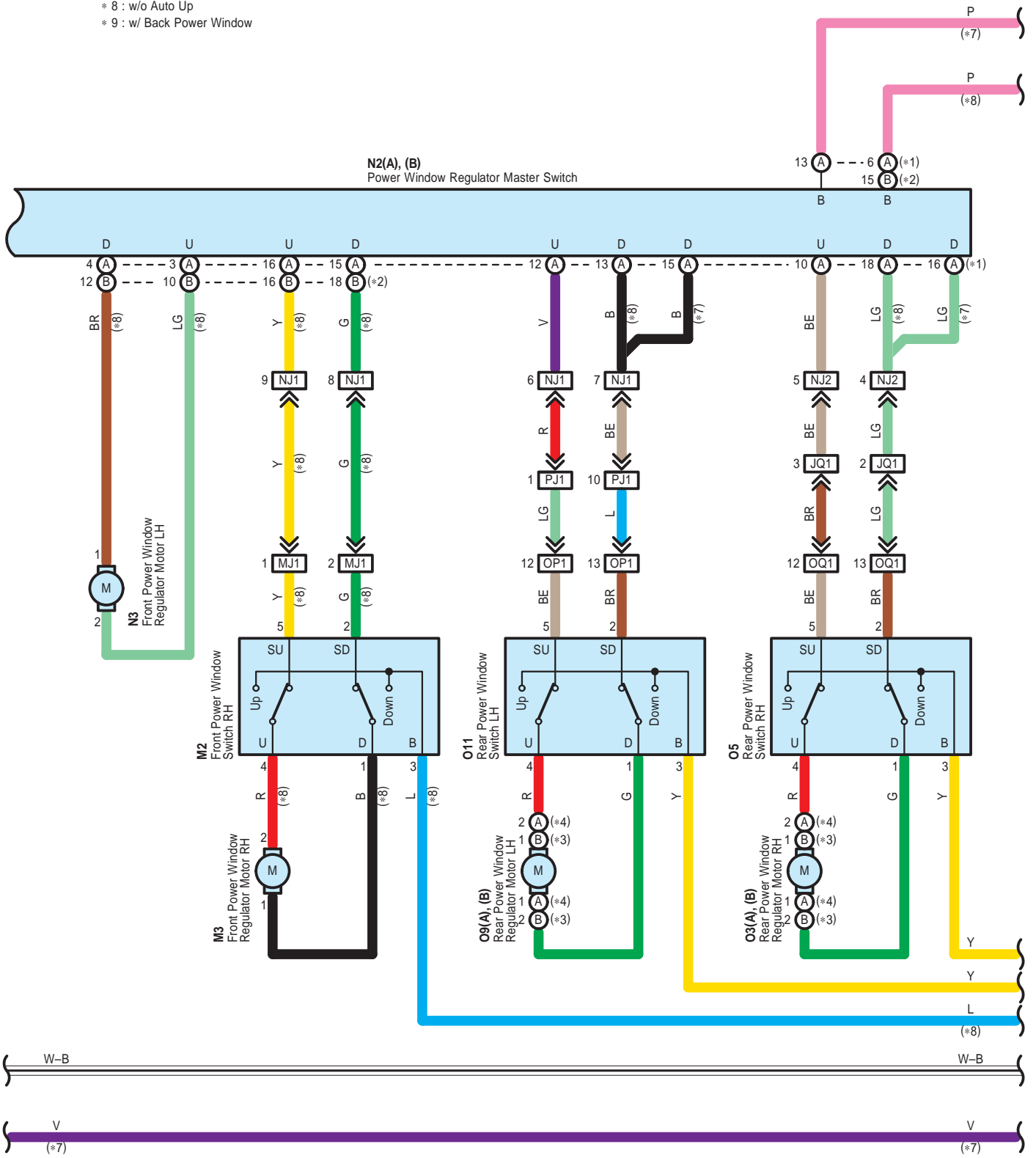



# Power Window

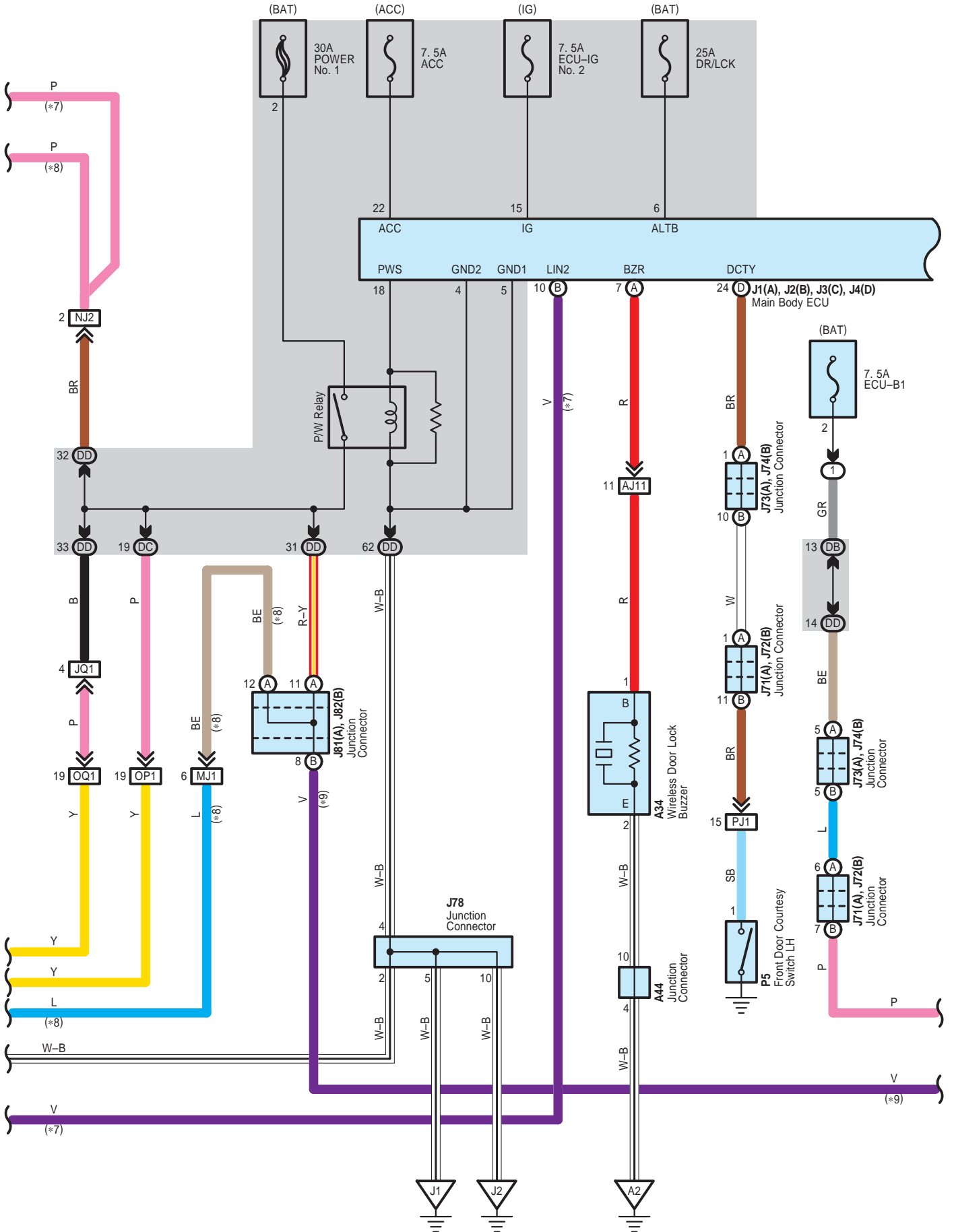

# Power Window

- \* 3 : Double Cab
- \* 4 : CrewMax
- \* 5 : w/ Power Seat
- \* 6 : w/o Power Seat
- \* 9 : w/ Back Power Window
- \* 10 : Except 3UR-FBE
- \* 11 : 3UR-FBE

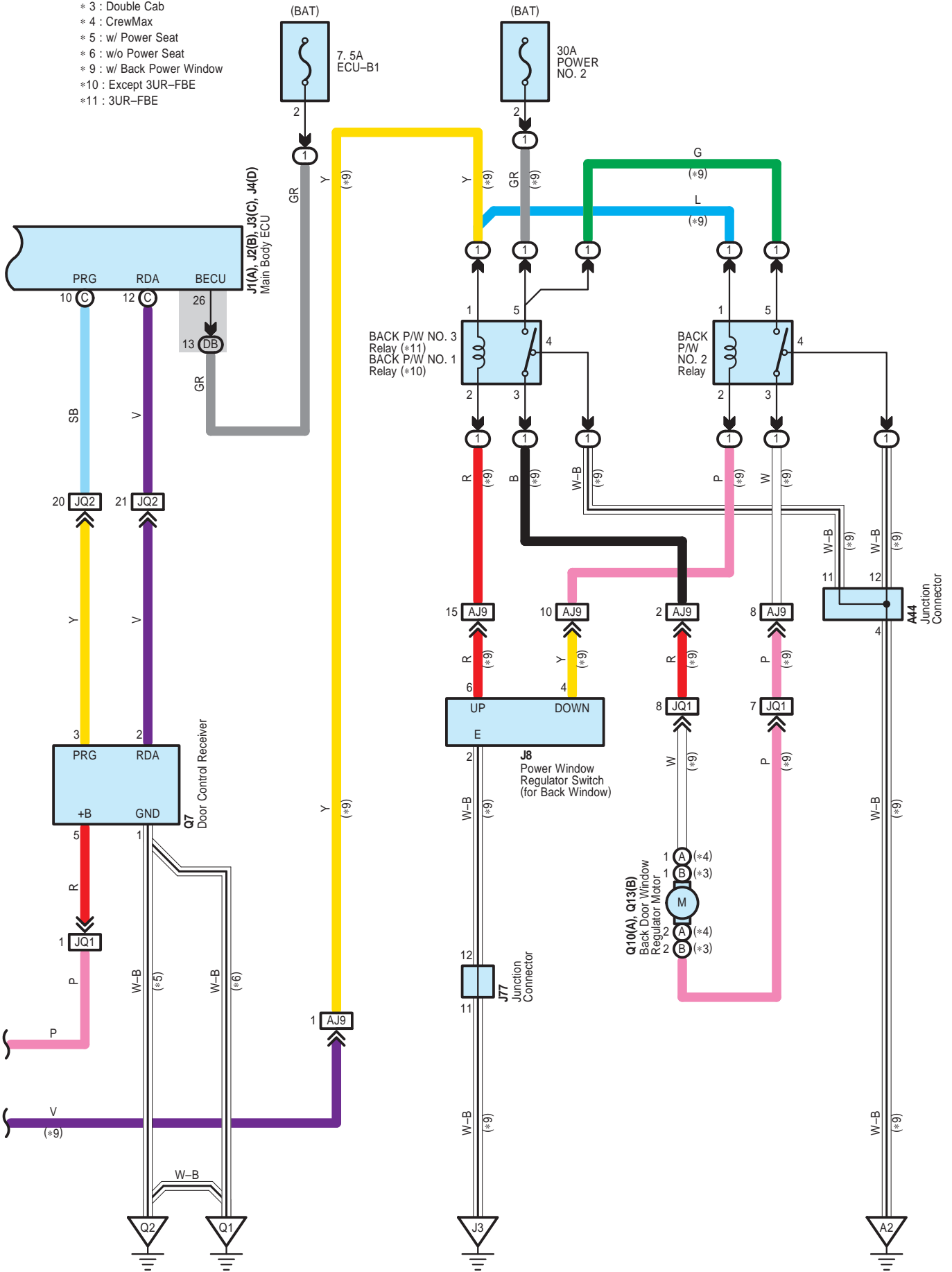

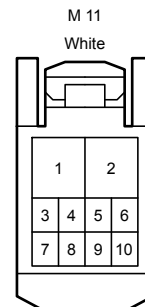
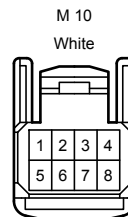
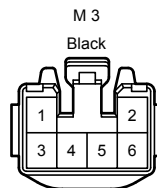
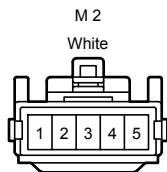
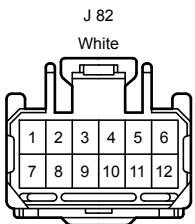
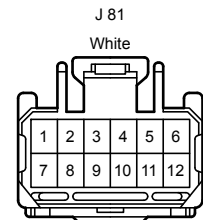
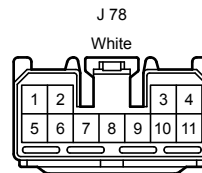
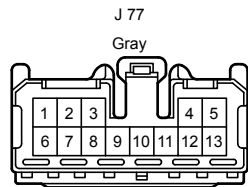
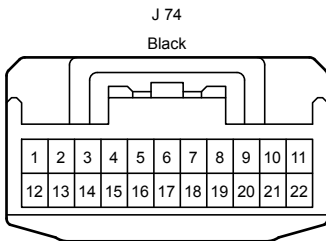
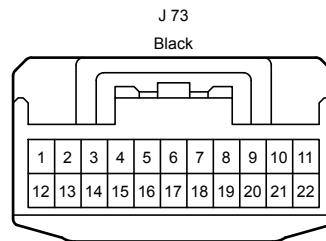
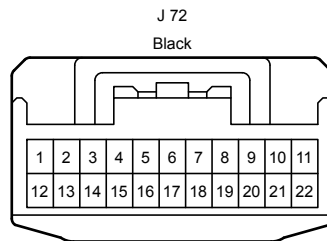
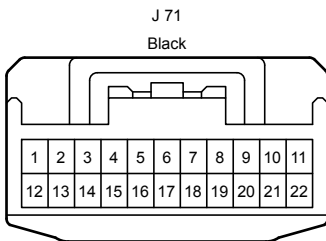
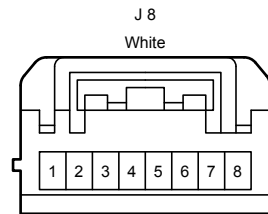
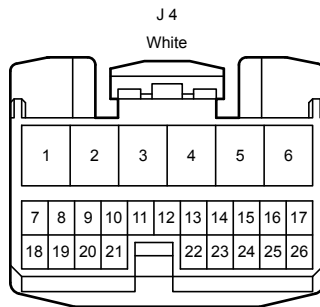
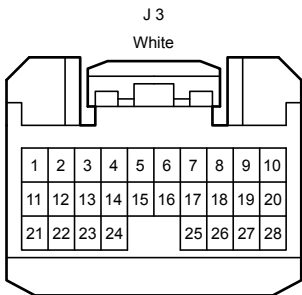
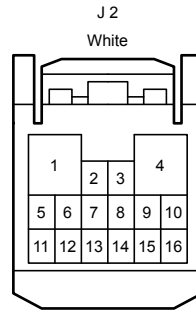
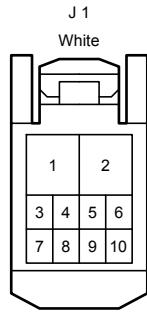
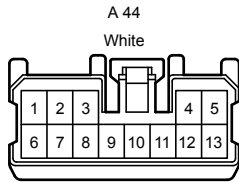
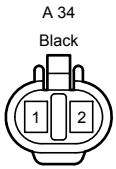

Power Window

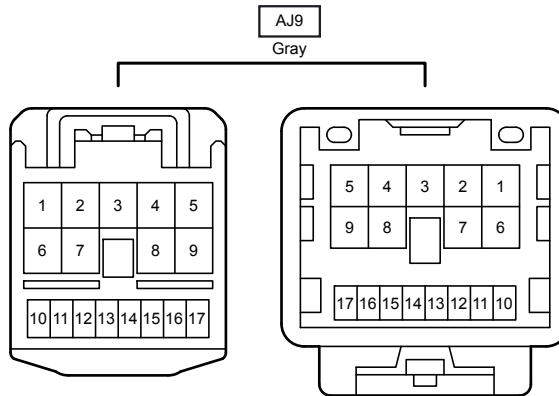
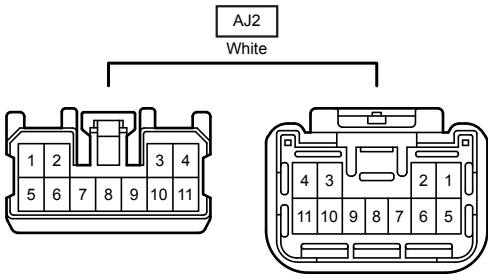
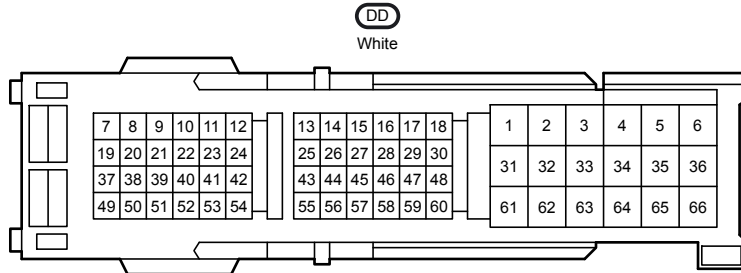
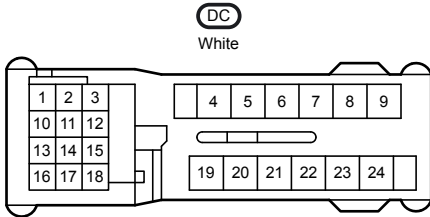
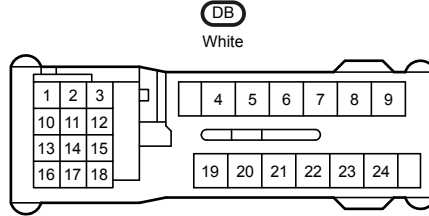
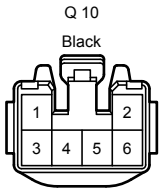
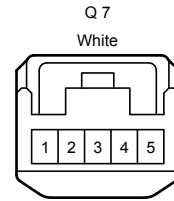
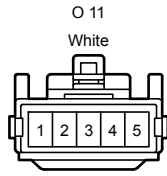
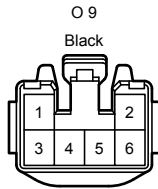
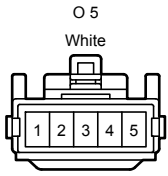
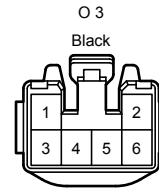
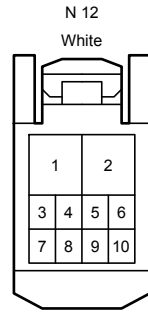
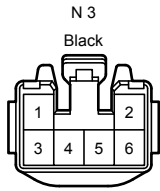
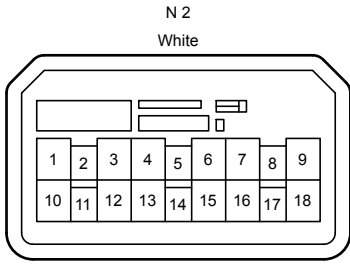

AJ11  
Gray

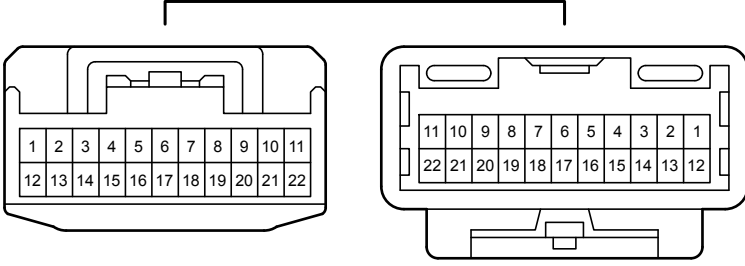

JQ1  
Gray

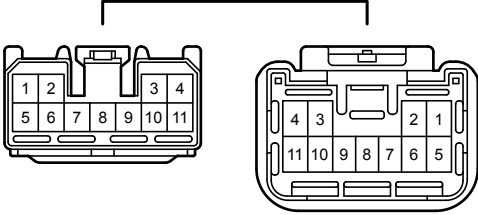

JQ2  
Gray

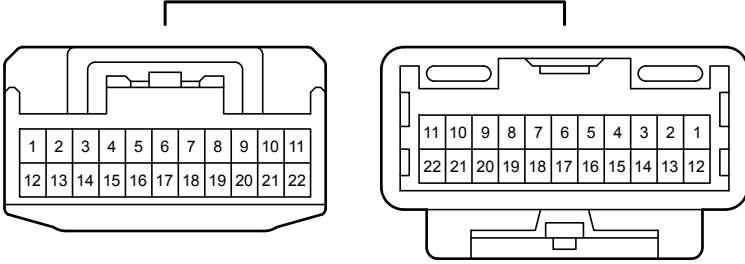

MJ1  
Blue

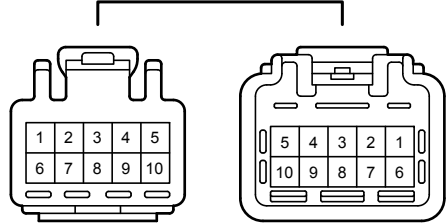

MJ3  
Blue

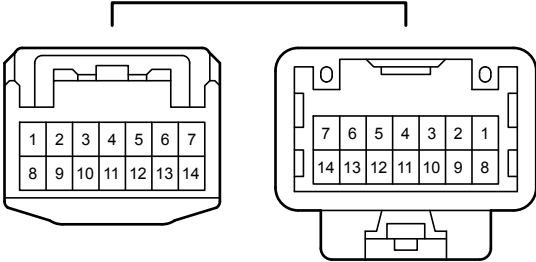

NJ1  
Blue

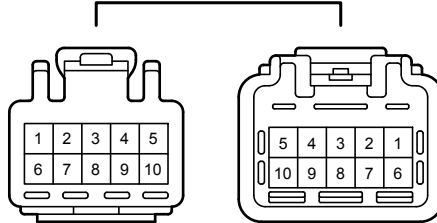

NJ2  
Blue

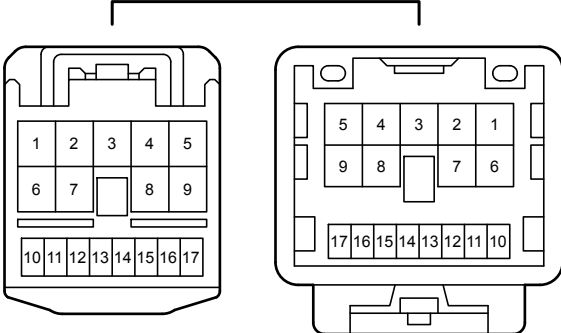

NJ3  
Blue

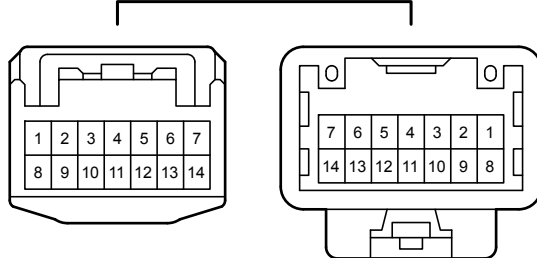

Power Window

OP1  
White

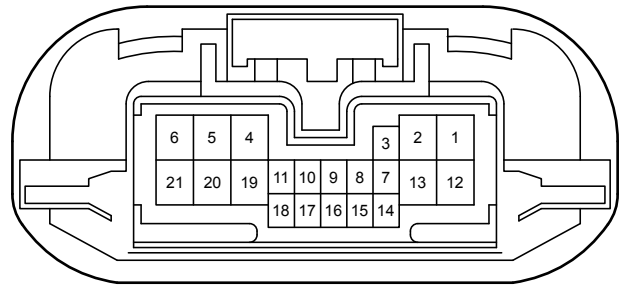
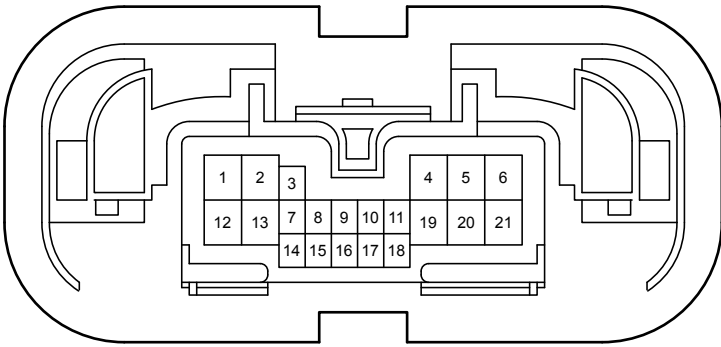

OQ1  
White

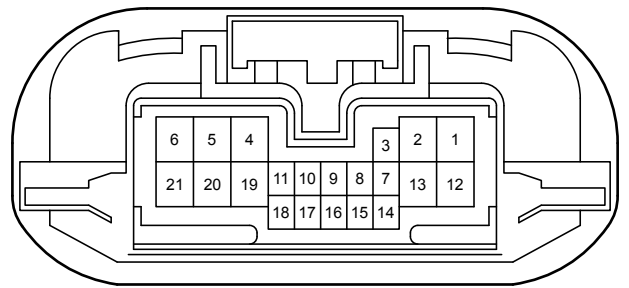
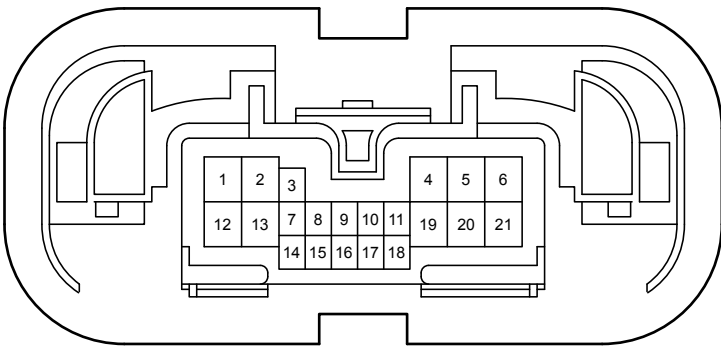

PJ1  
Black

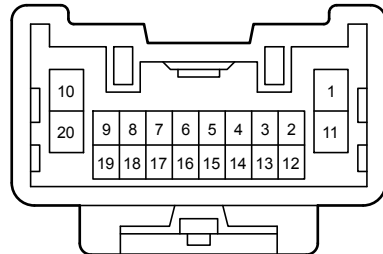
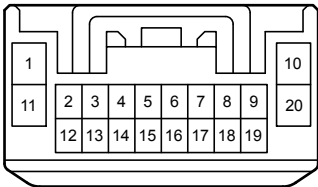

# Remote Control Mirror <w/o Seat Position Memory>

\* 1 : w/ Retractor

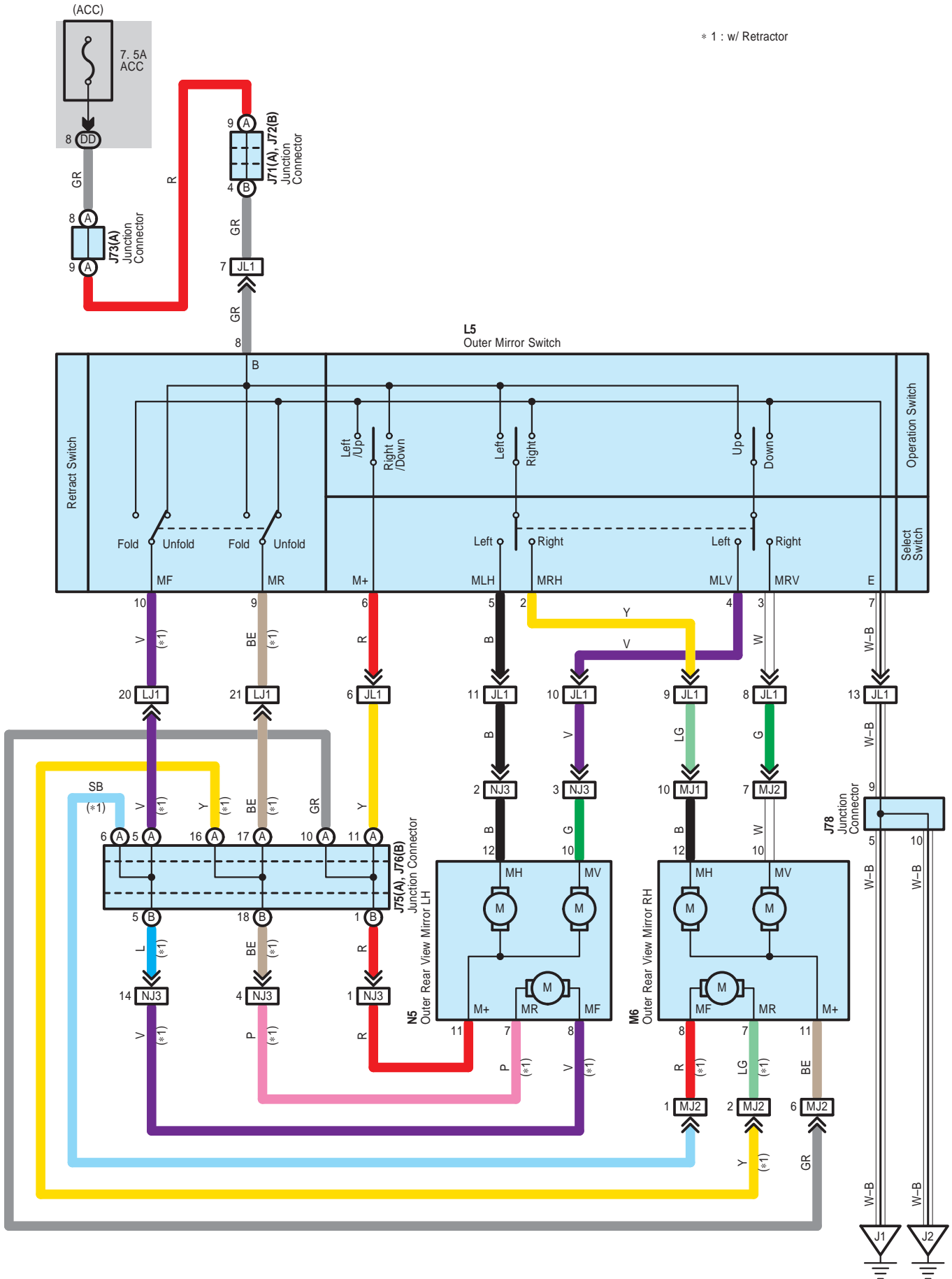

Remote Control Mirror <w/o Seat Position Memory>

J 71  
Black

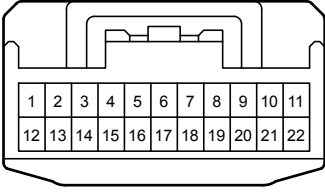

J 72  
Black

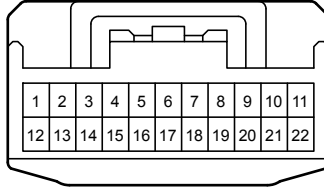

J 73  
Black

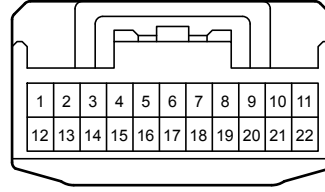

J 75  
White

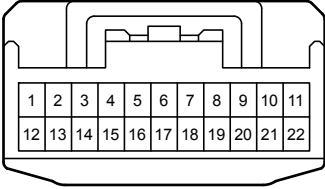

J 76  
White

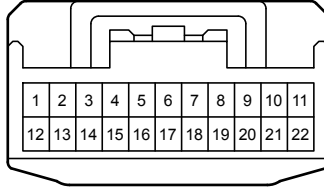

J 78  
White

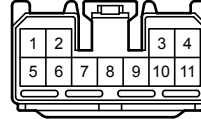

L 5  
White

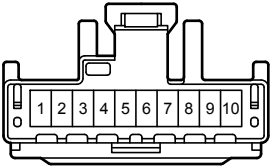

M 6  
White

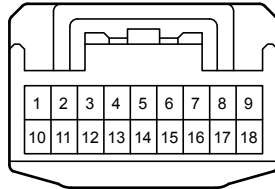

N 5  
White

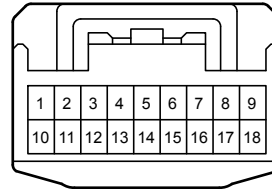

DD  
White

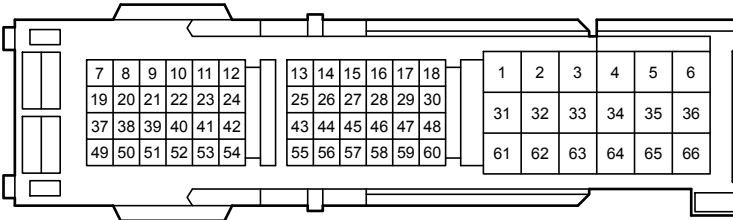

JL1  
White

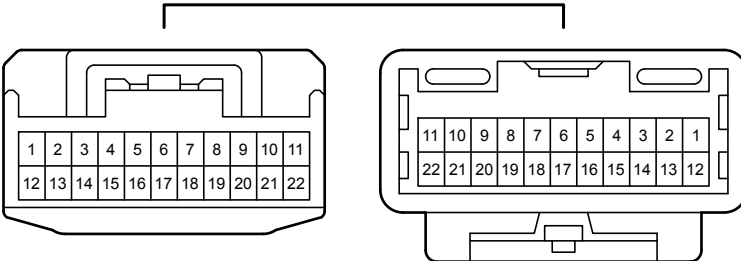

LJ1  
White

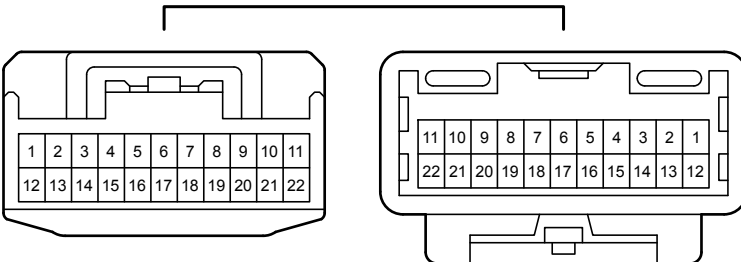

MJ1  
Blue

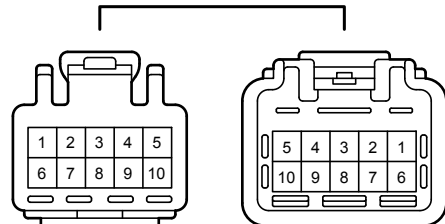



Remote Control Mirror <w/o Seat Position Memory>

MJ2  
Blue

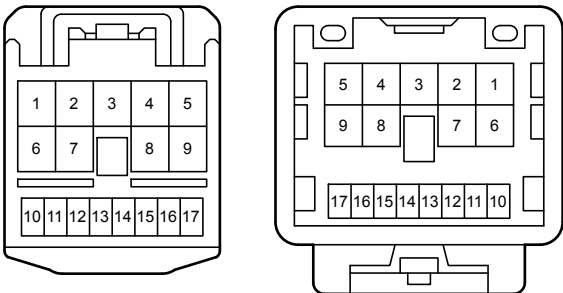

NJ3  
Blue

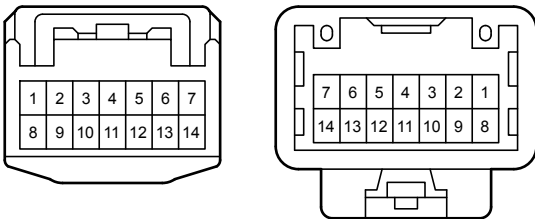

Remote Control Mirror <w/ Seat Position Memory>

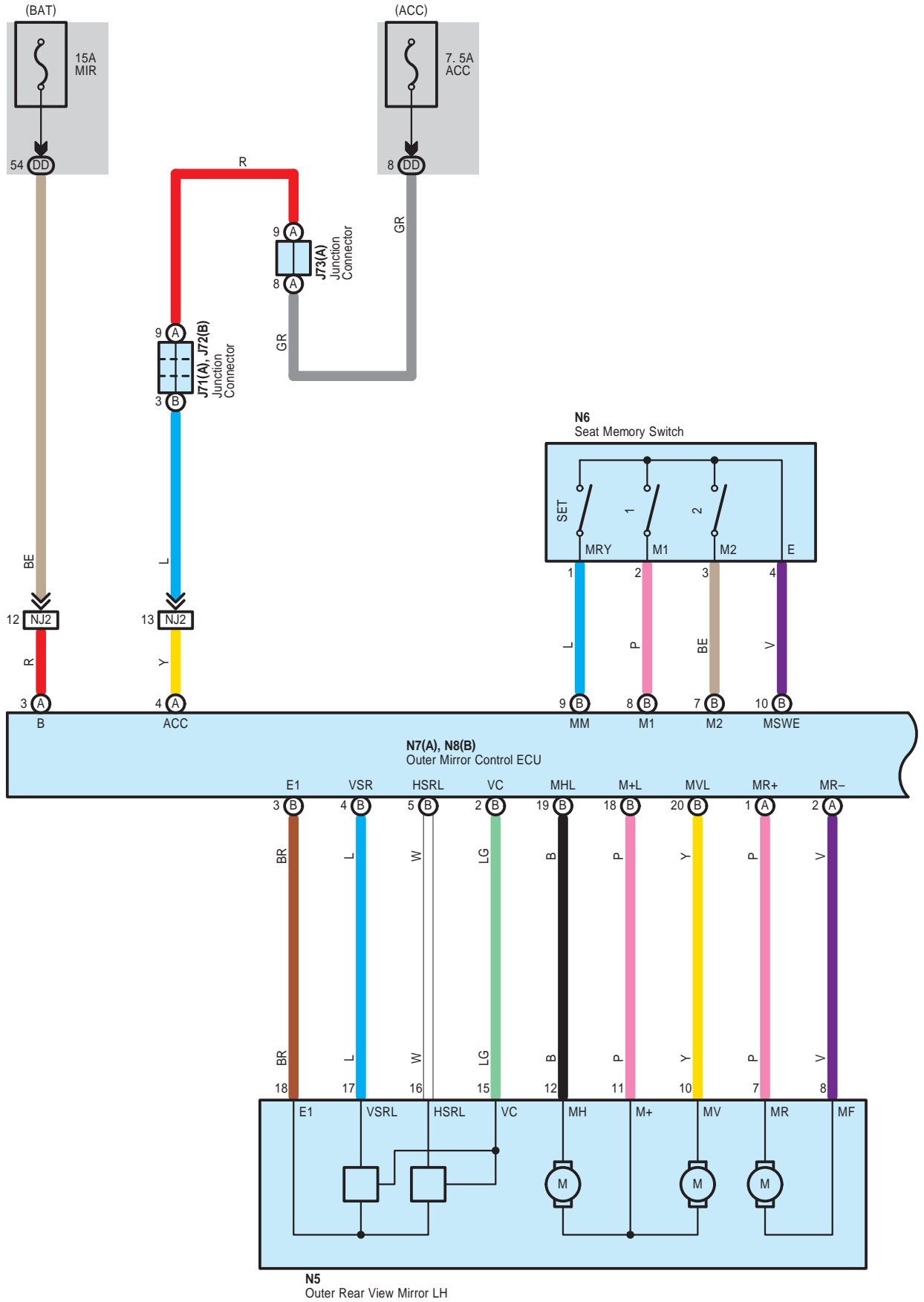

Remote Control Mirror <w/ Seat Position Memory>

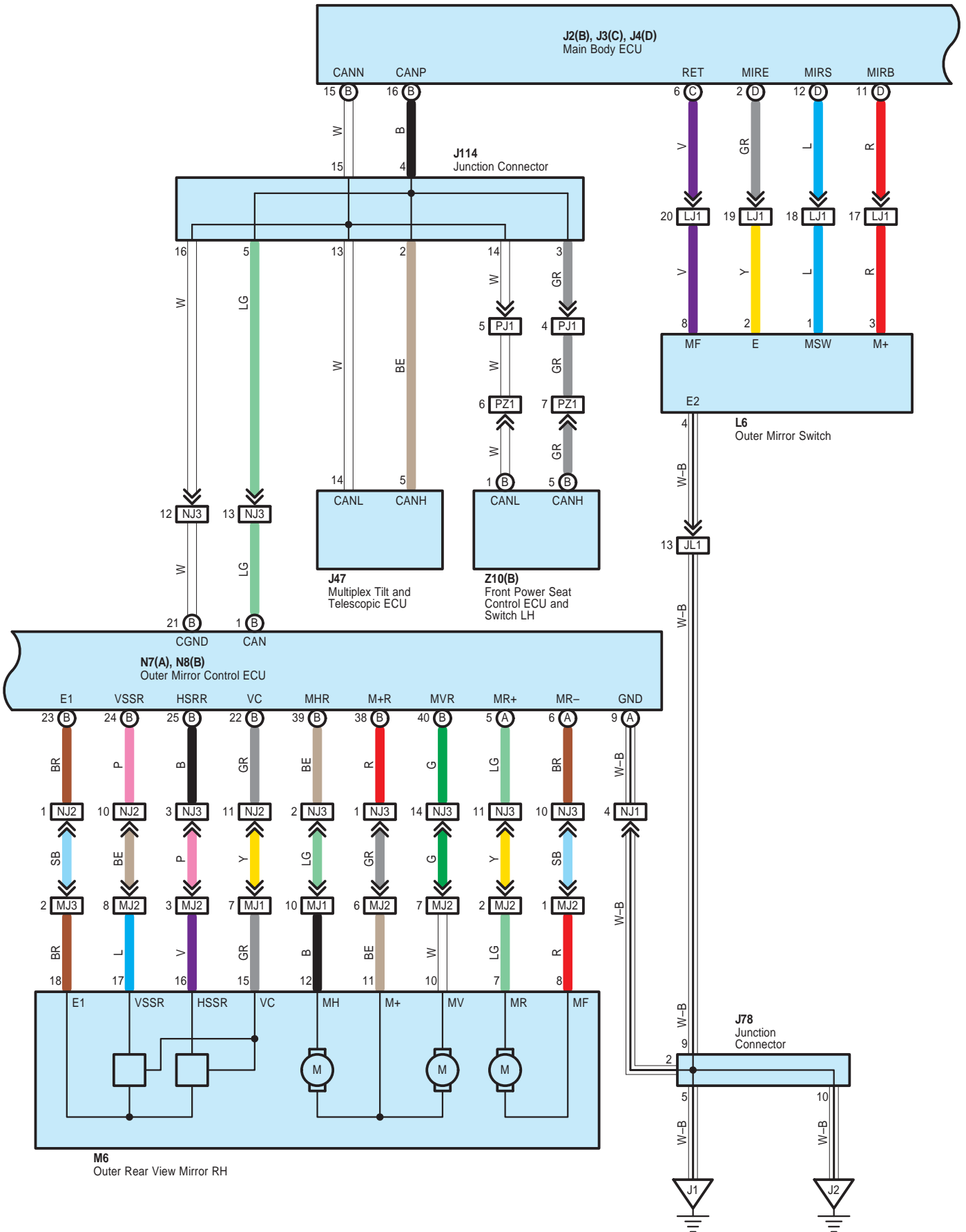

Remote Control Mirror <w/ Seat Position Memory>

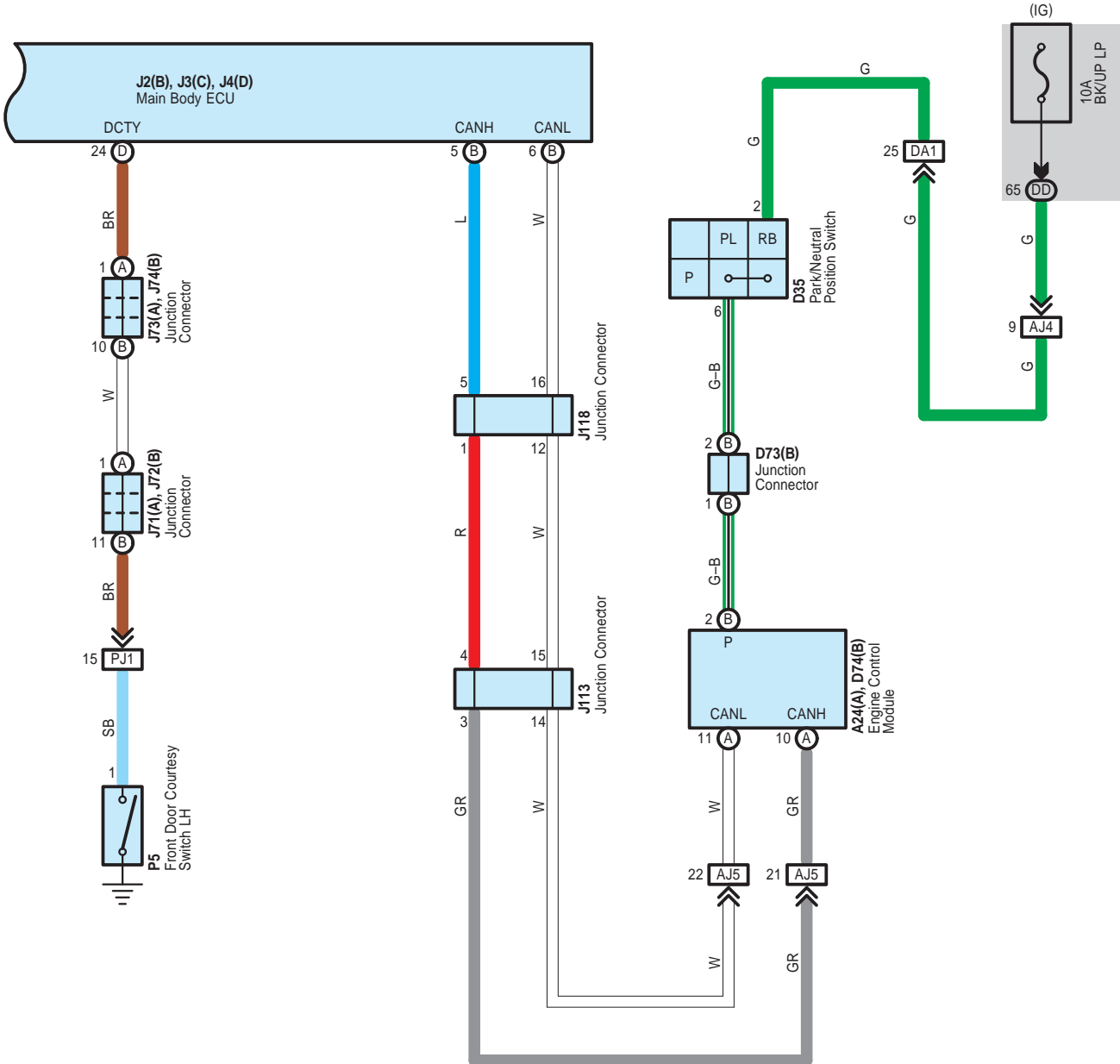

Remote Control Mirror <w/ Seat Position Memory>

A 24  
Black

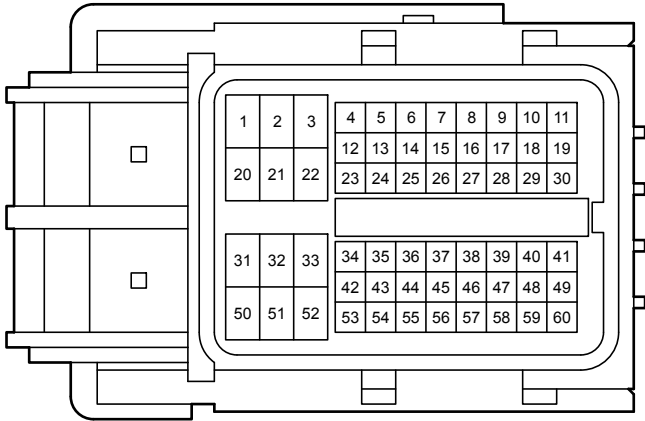

D 35  
Gray

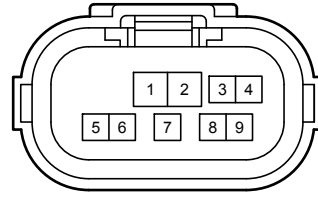

D 73  
Blue

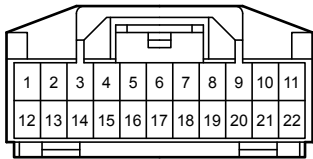

D 74  
Black

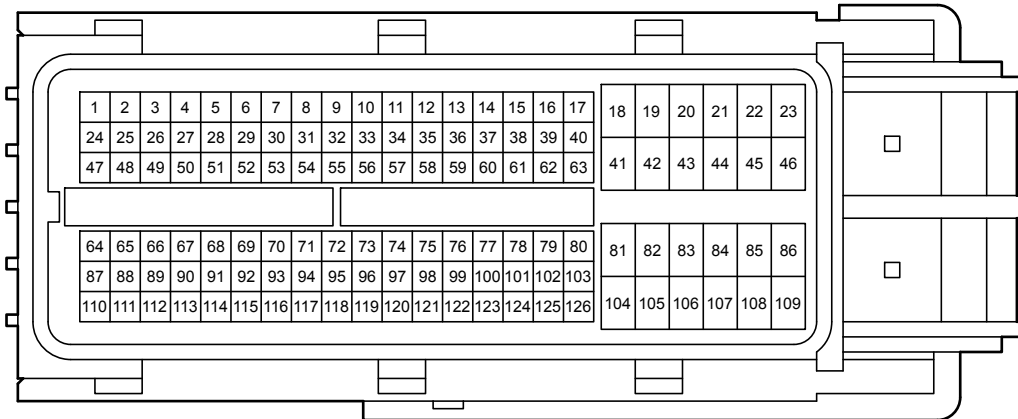

J 2  
White

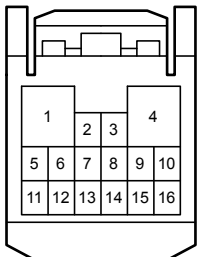

J 3  
White

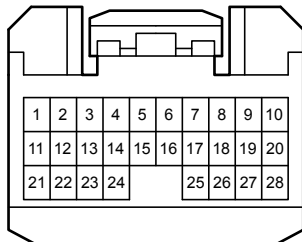

J 4  
White

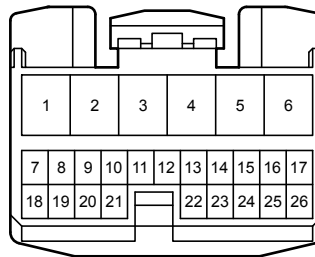

Remote Control Mirror <w/ Seat Position Memory>

J 47  
White

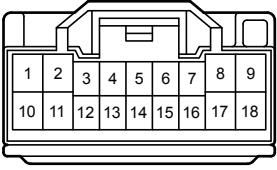

J 71  
Black

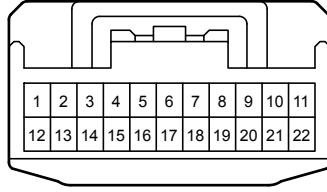

J 72  
Black

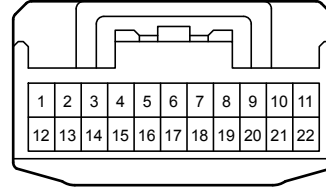

J 73  
Black

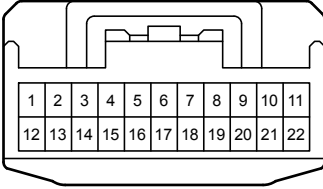

J 74  
Black

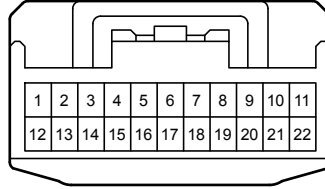

J 78  
White

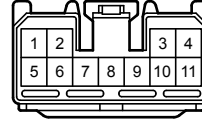

J113  
Gray

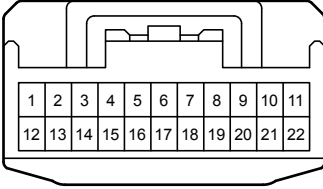

J114  
Gray

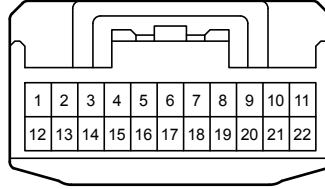

J118  
Gray

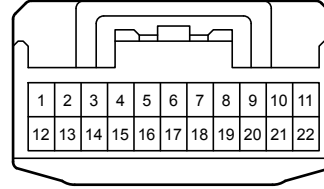

L 6  
Black

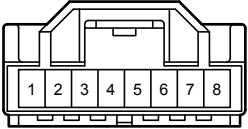

M 6  
White

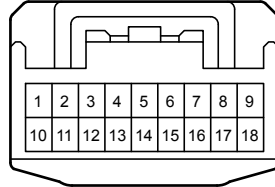

N 5  
White

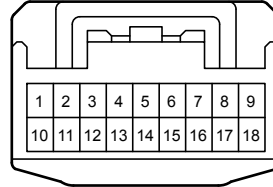

N 6  
White

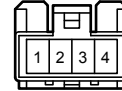

N 7  
White

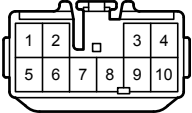

N 8  
White

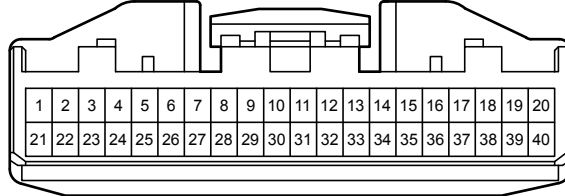

P 5  
White



Z 10  
White

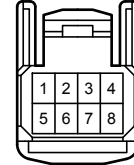

DD  
White

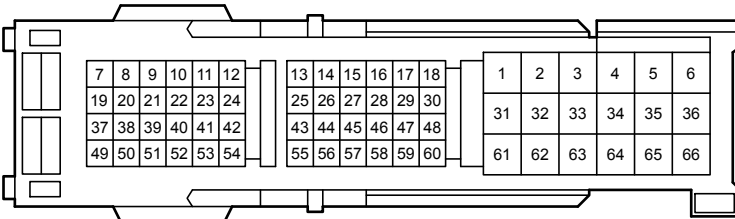

Remote Control Mirror <w/ Seat Position Memory>

AJ4  
White

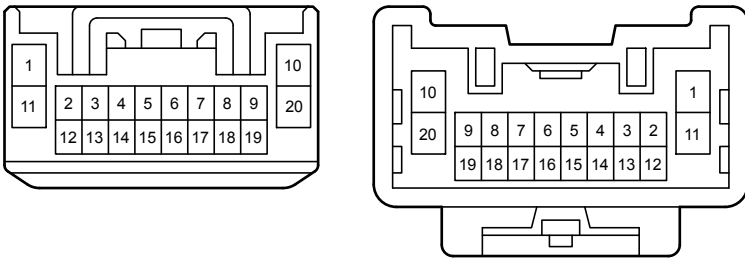

AJ5  
White

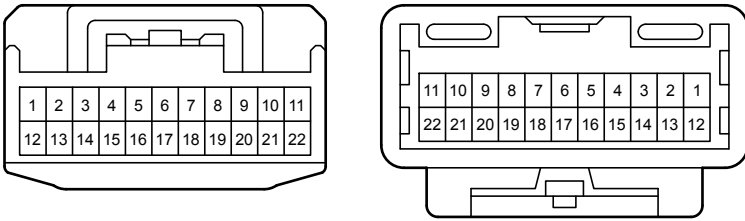

DA1  
White

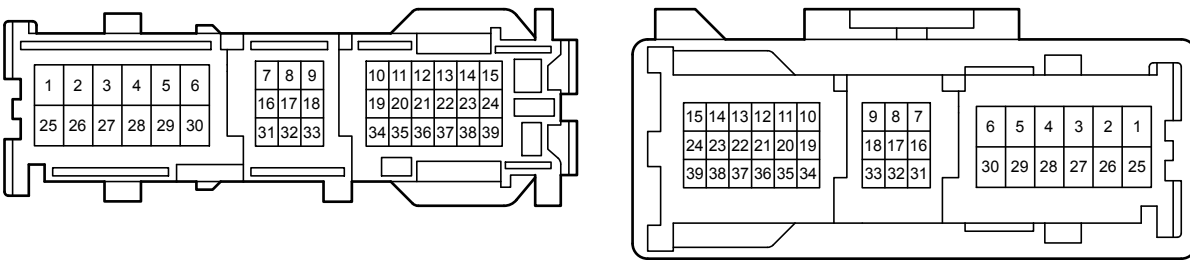

JL1  
White

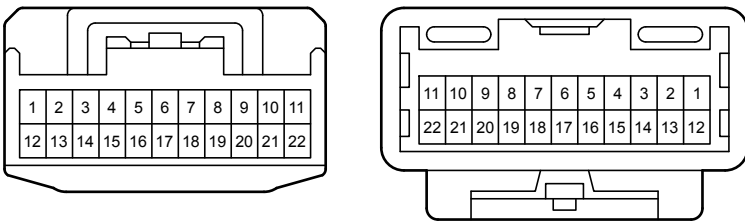

LJ1  
White

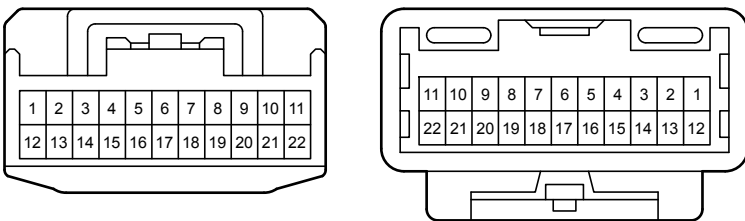

MJ1  
Blue

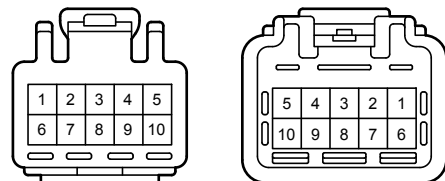

Remote Control Mirror <w/ Seat Position Memory>

MJ2  
Blue

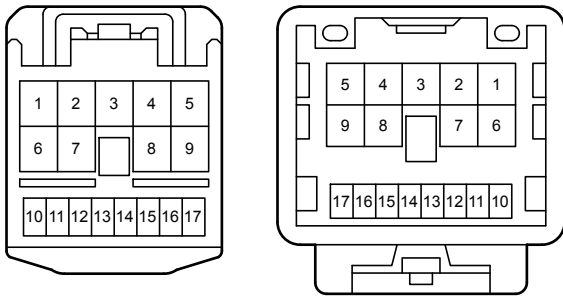

MJ3  
Blue

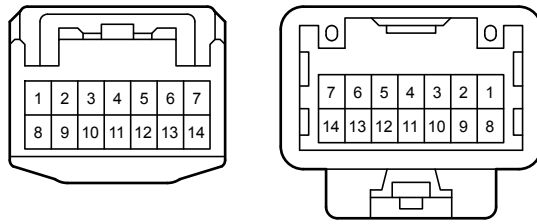

NJ1  
Blue

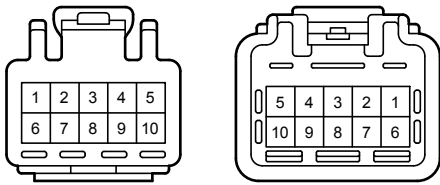

NJ2  
Blue

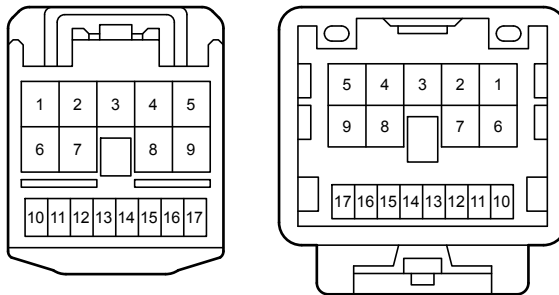

NJ3  
Blue

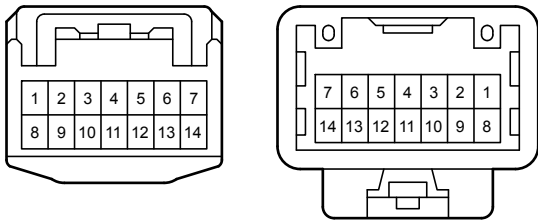

PJ1  
Black

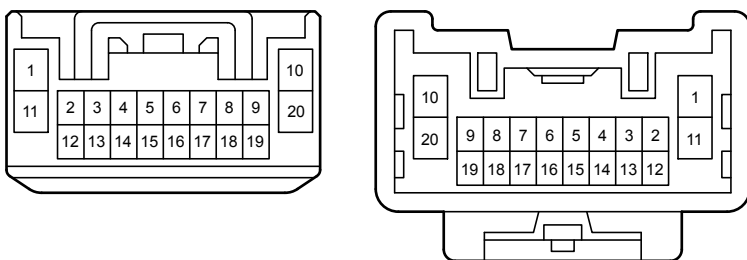



PZ1  
White

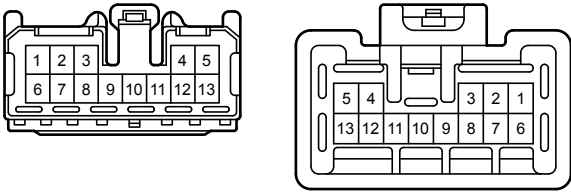

# Rear Window Defogger

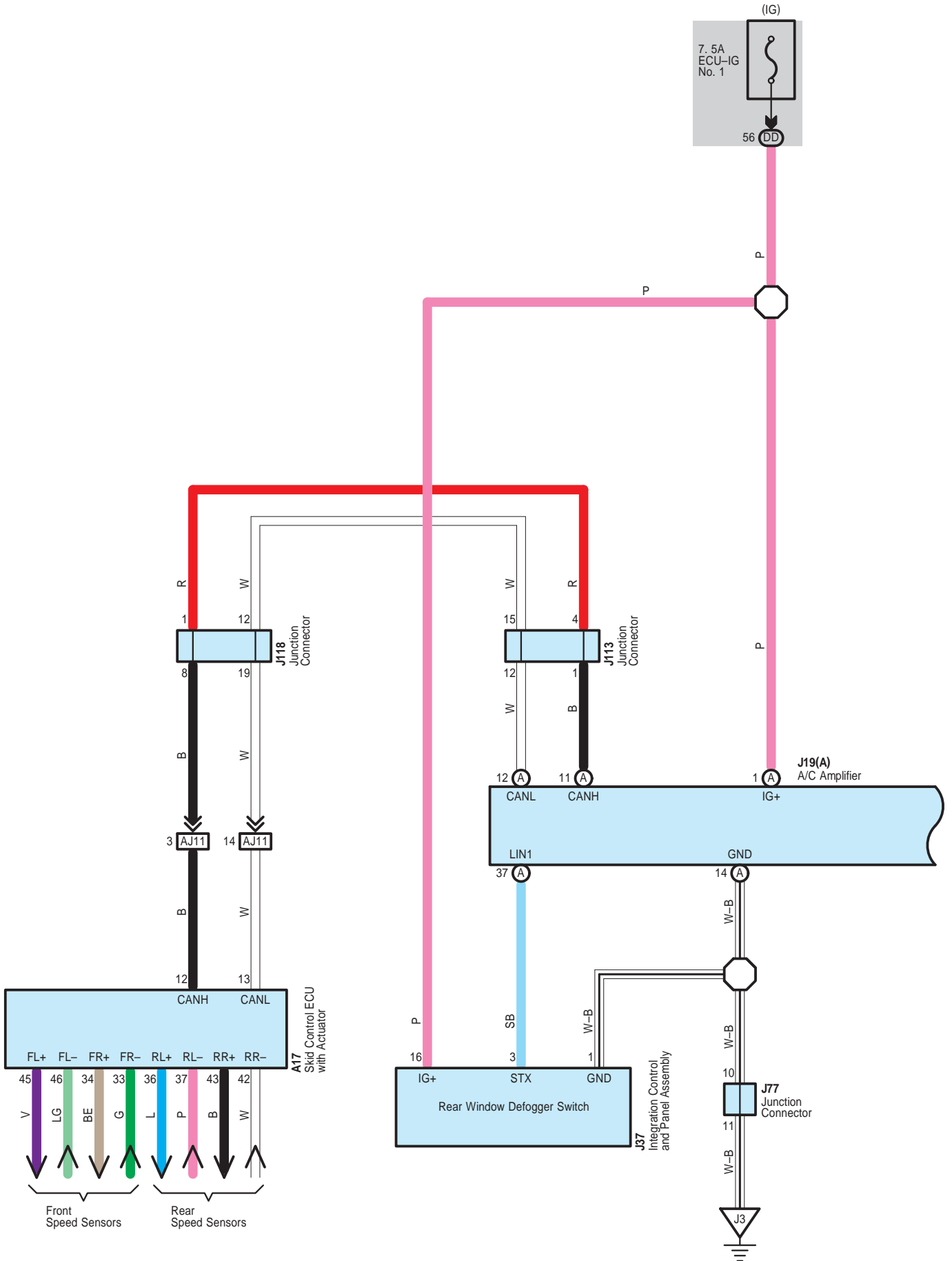

# Rear Window Defogger

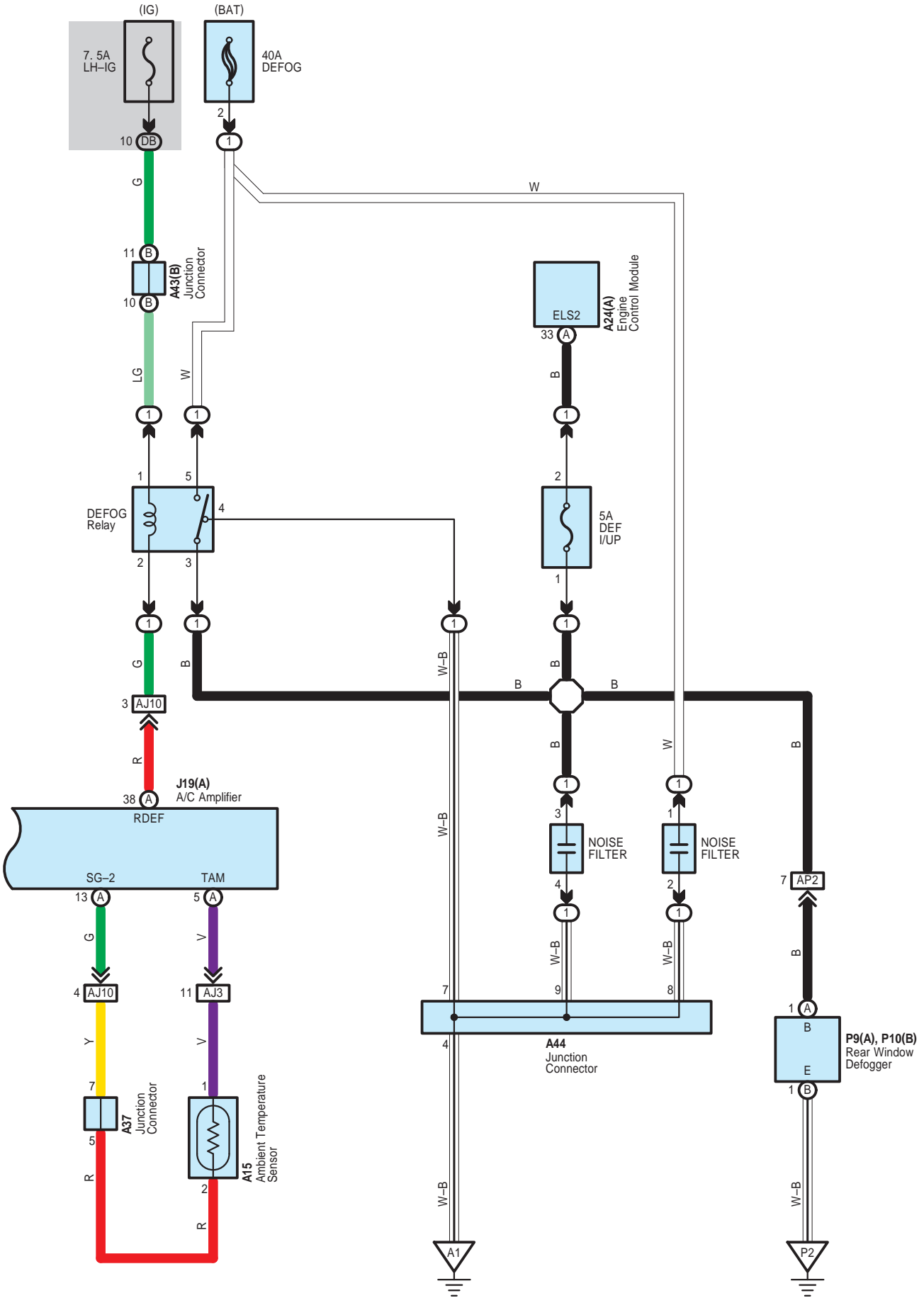

# Rear Window Defogger

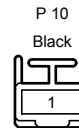
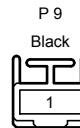
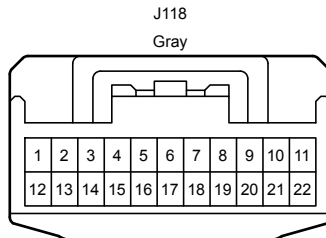
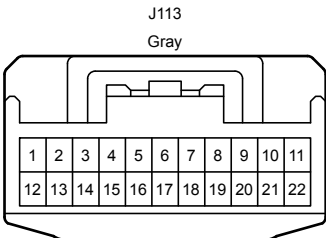
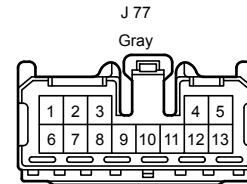
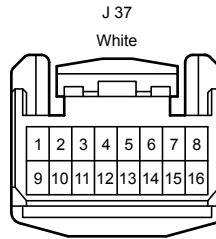
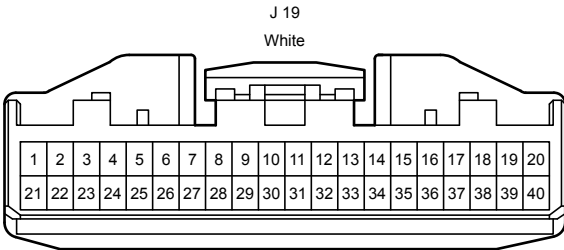
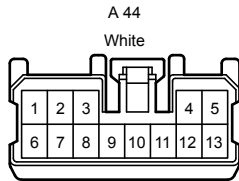
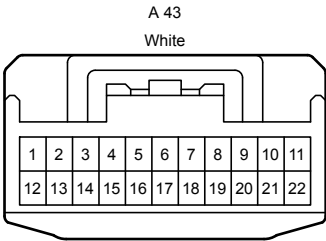
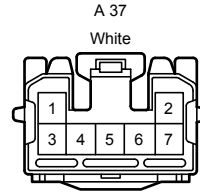
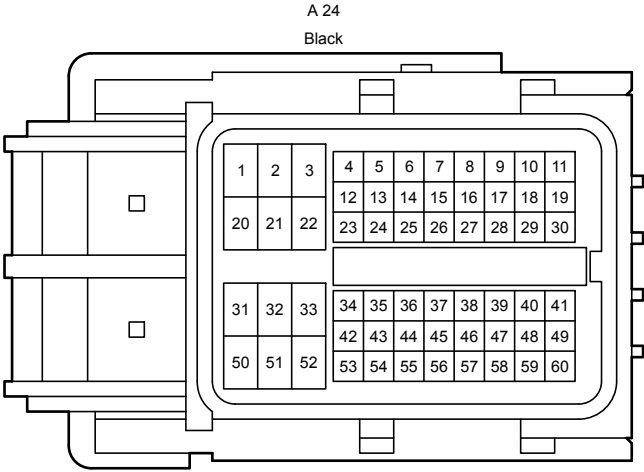
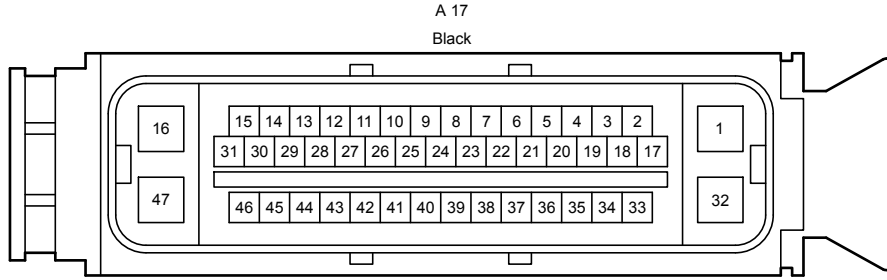

## Rear Window Defogger

**DB**  
White

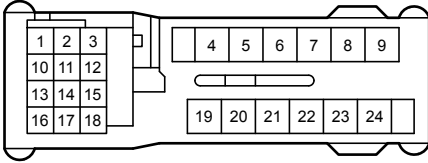

**DD**  
White

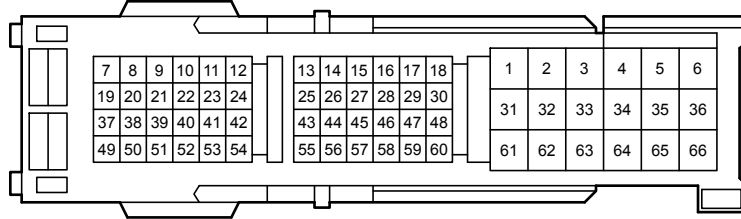

**AJ3**  
White

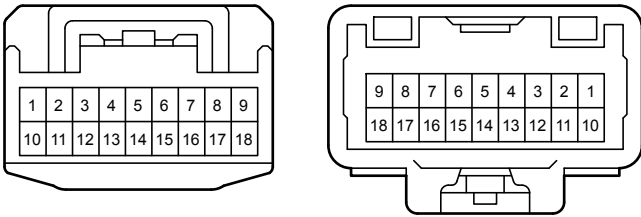

**AJ10**  
Gray

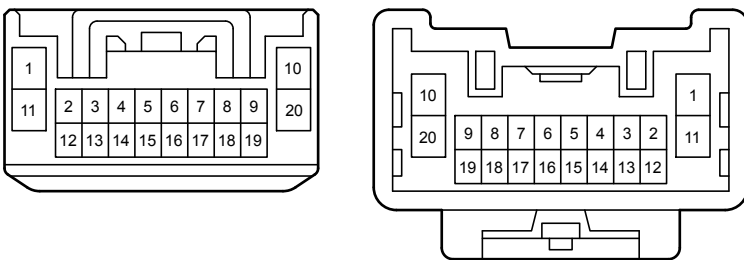

**AJ11**  
Gray

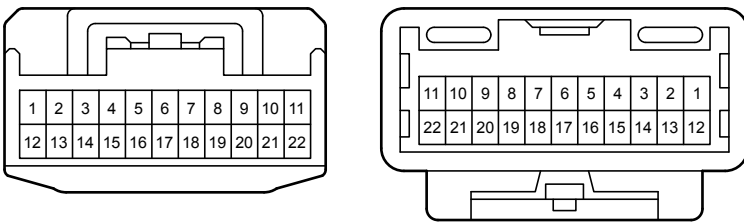

**AP2**  
White

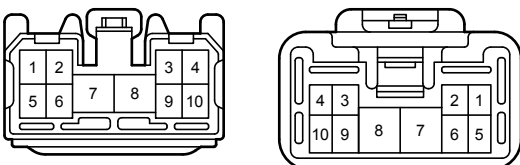

Seat Heater <w/o Climate Control Seat>

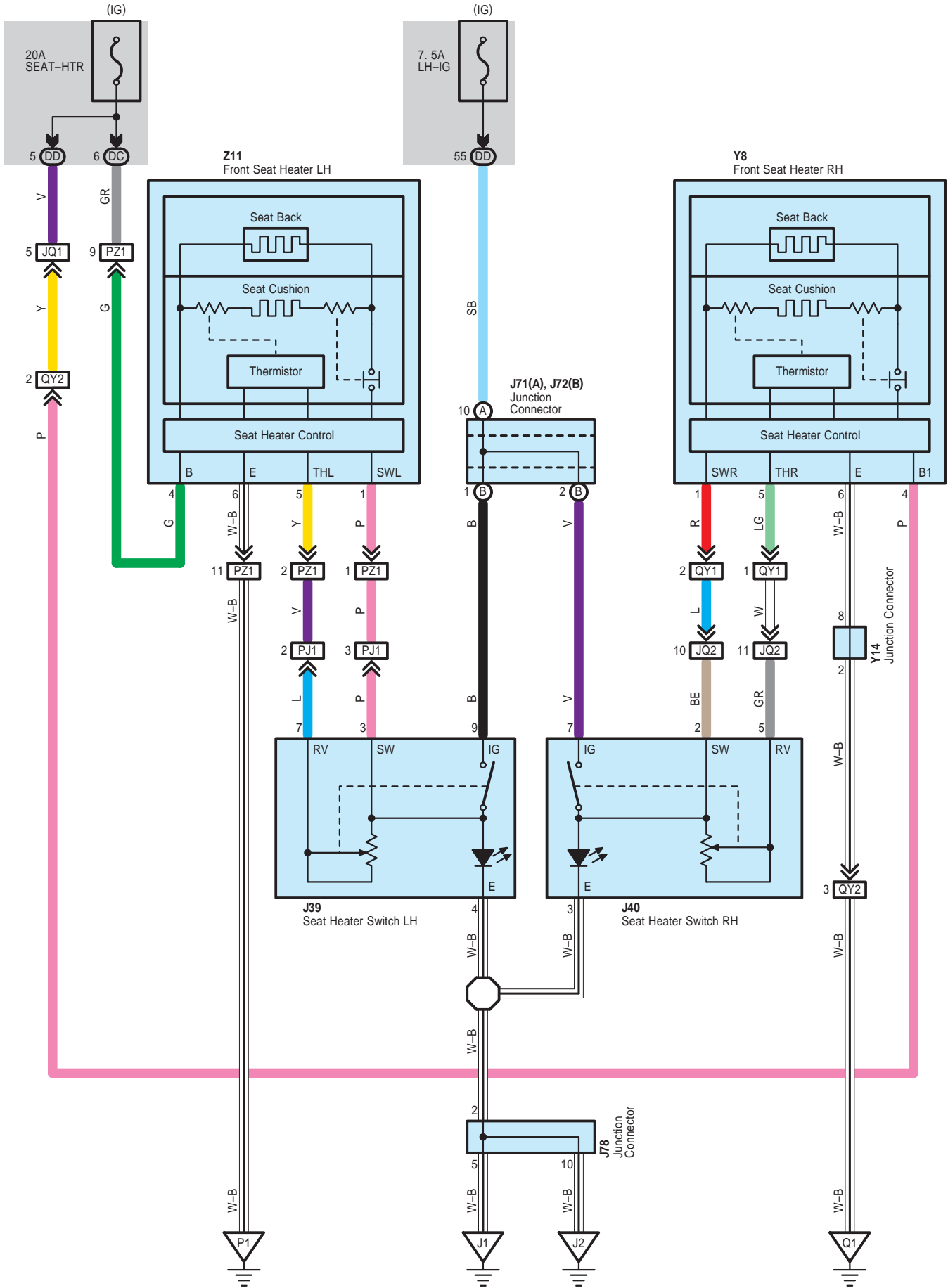

Seat Heater <w/o Climate Control Seat>

J 39

Black

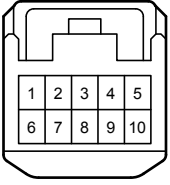

J 40

Black

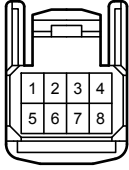

J 71

Black

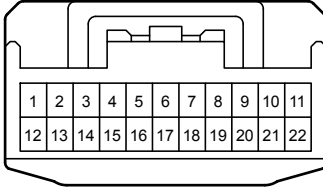

J 72

Black

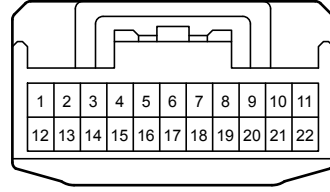

J 78

White

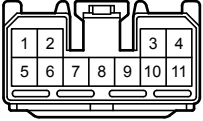

Y 8

White



Y 14

White

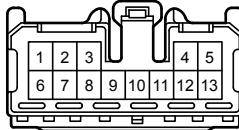

Z 11

White



DC

White

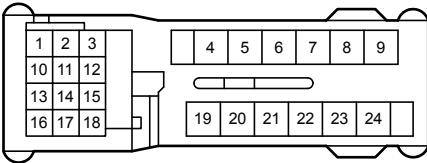

DD

White

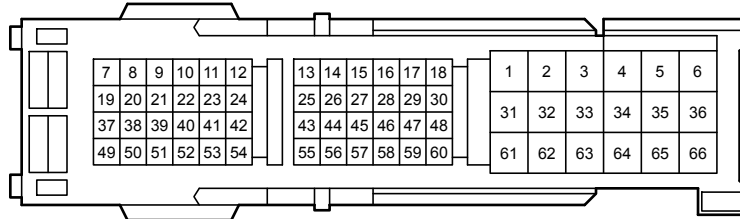

JQ1

Gray

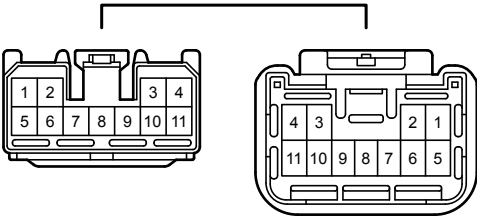

JQ2

Gray

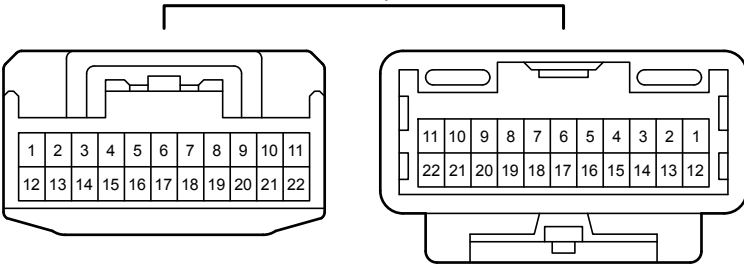

PJ1

Black

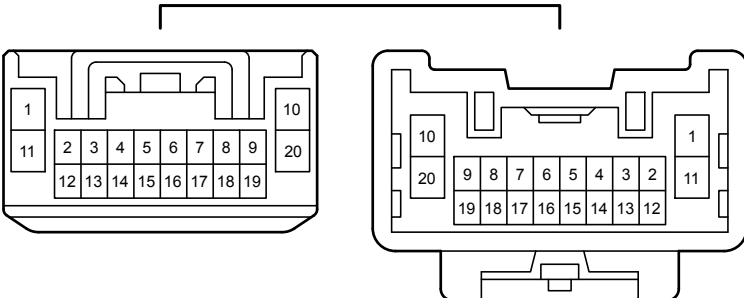

Seat Heater <w/o Climate Control Seat>

PZ1  
White

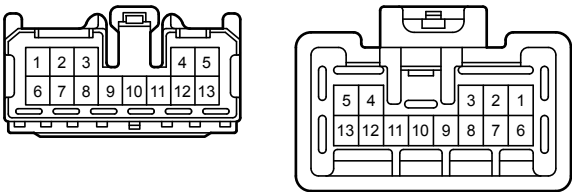

QY1  
White

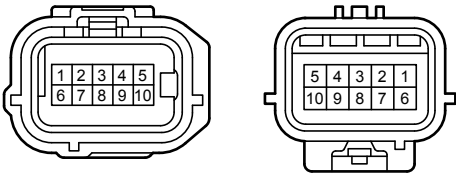

QY2  
White

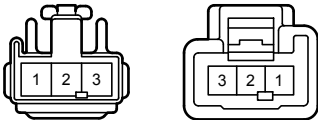



# Stop Light

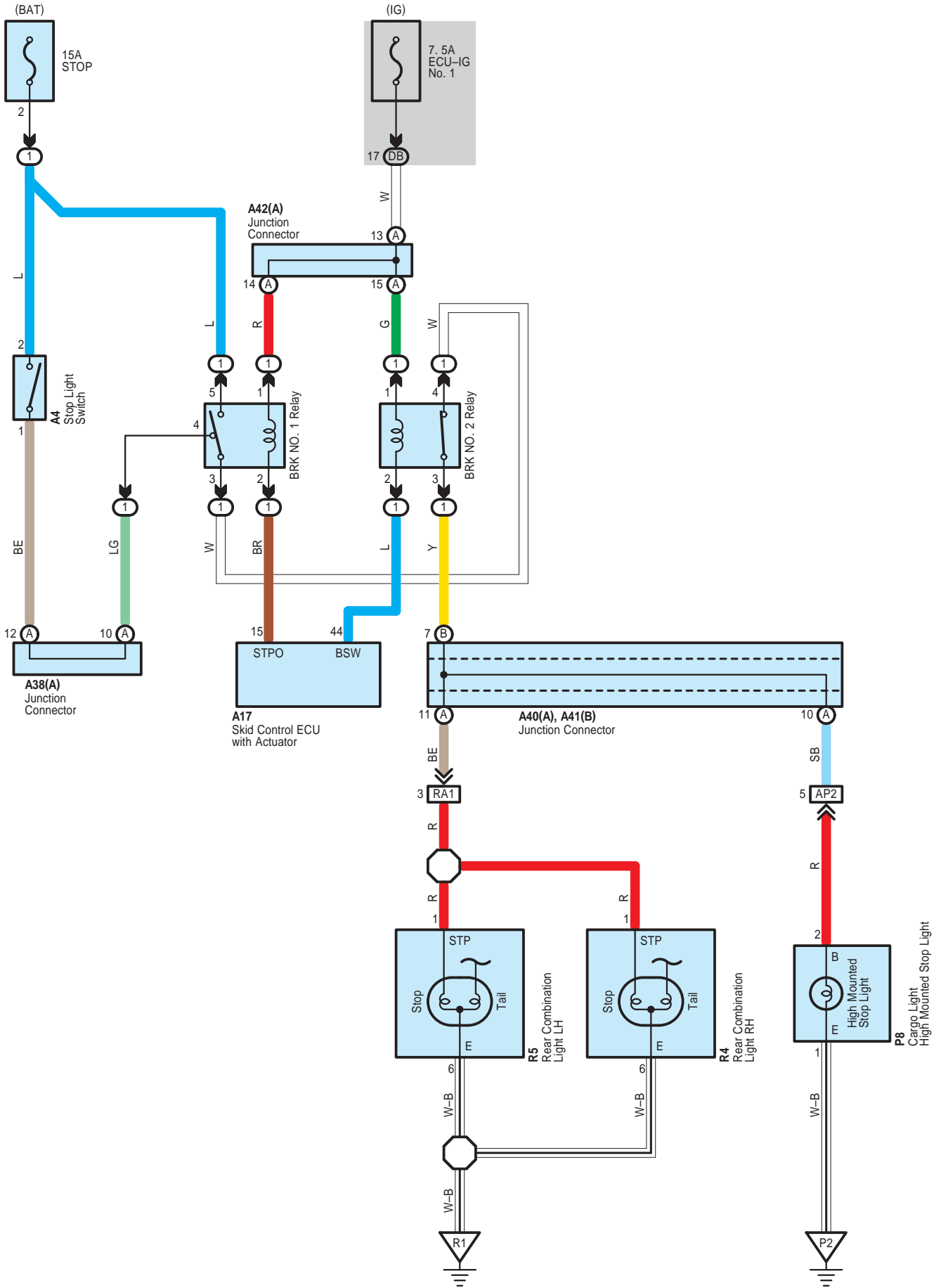



Shift Lock <Column Shift>

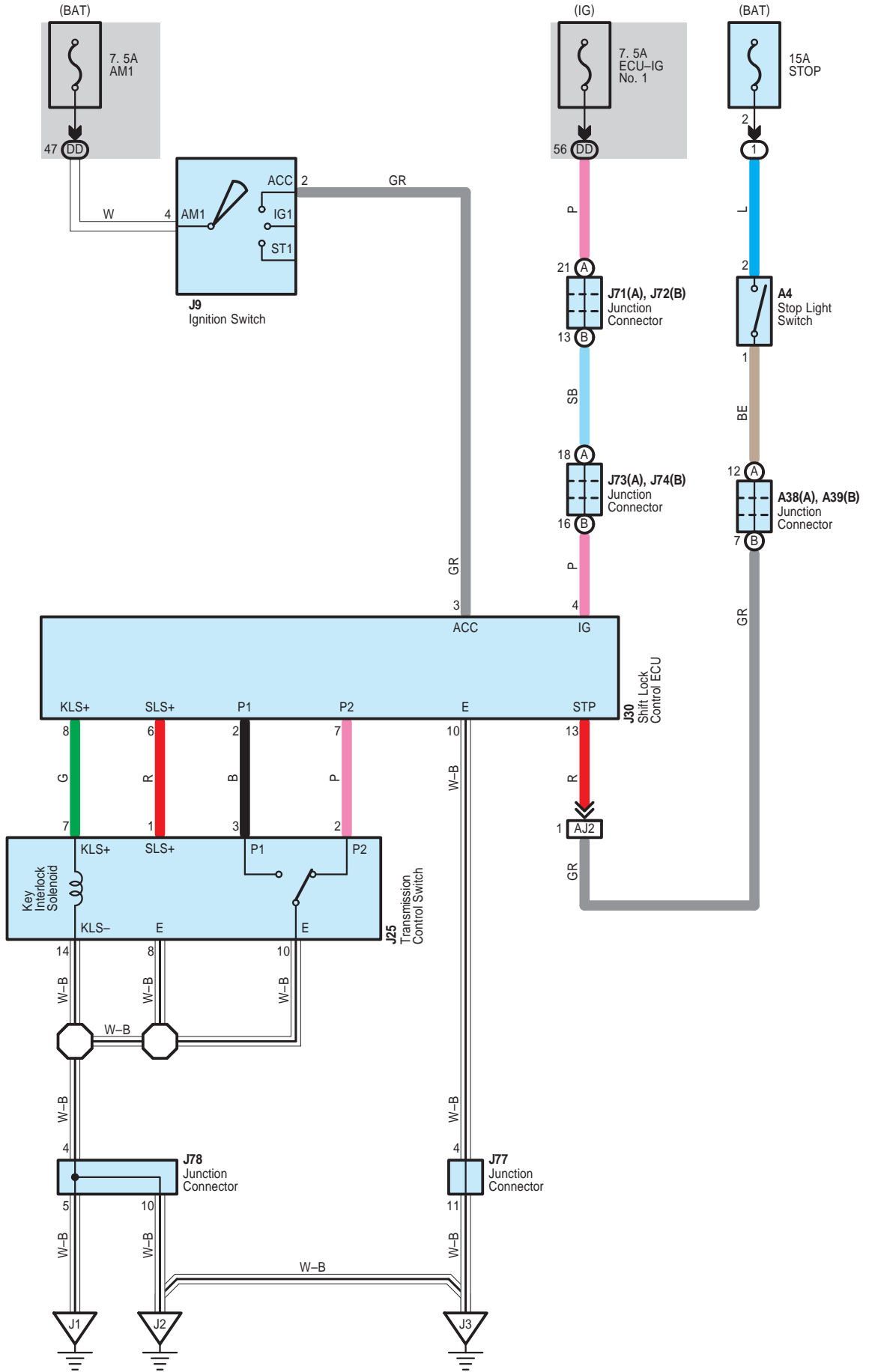

Shift Lock <Column Shift>

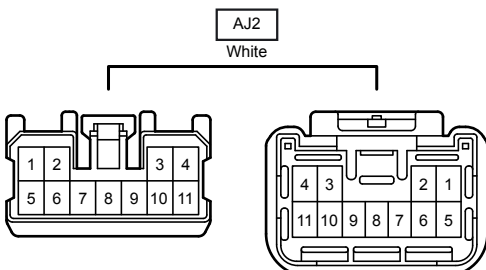
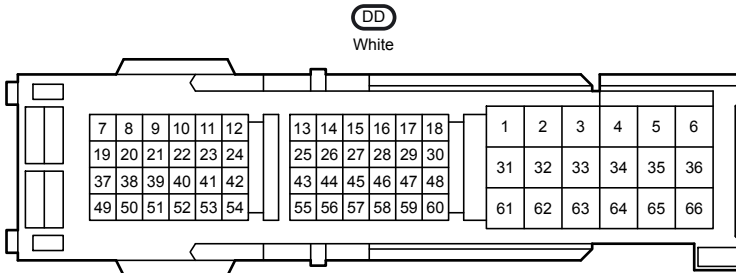
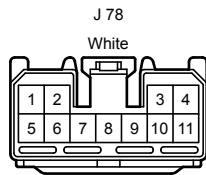
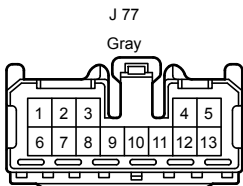
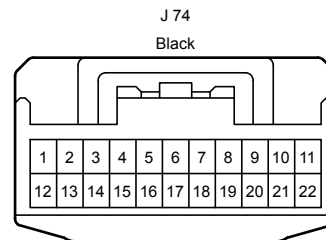
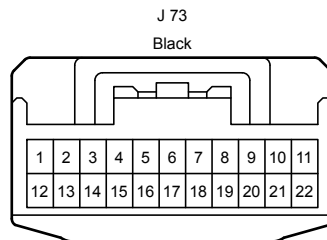
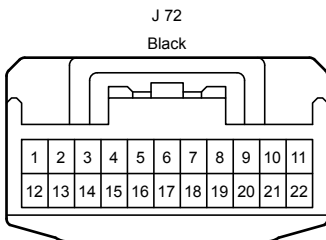
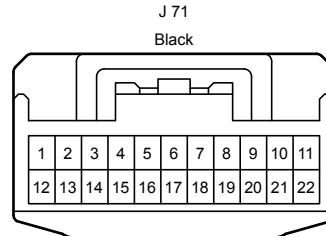
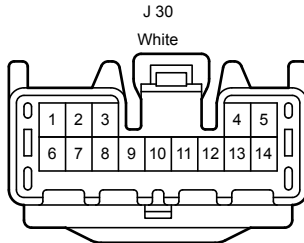
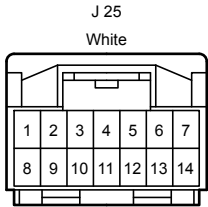
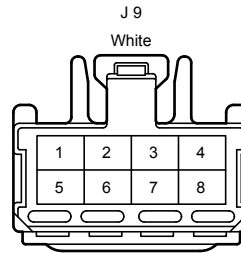
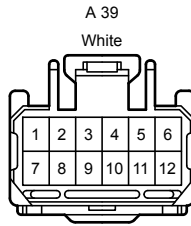
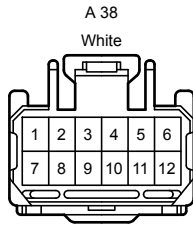
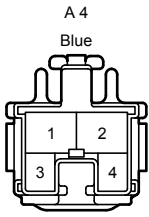

Shift Lock <Floor Shift>

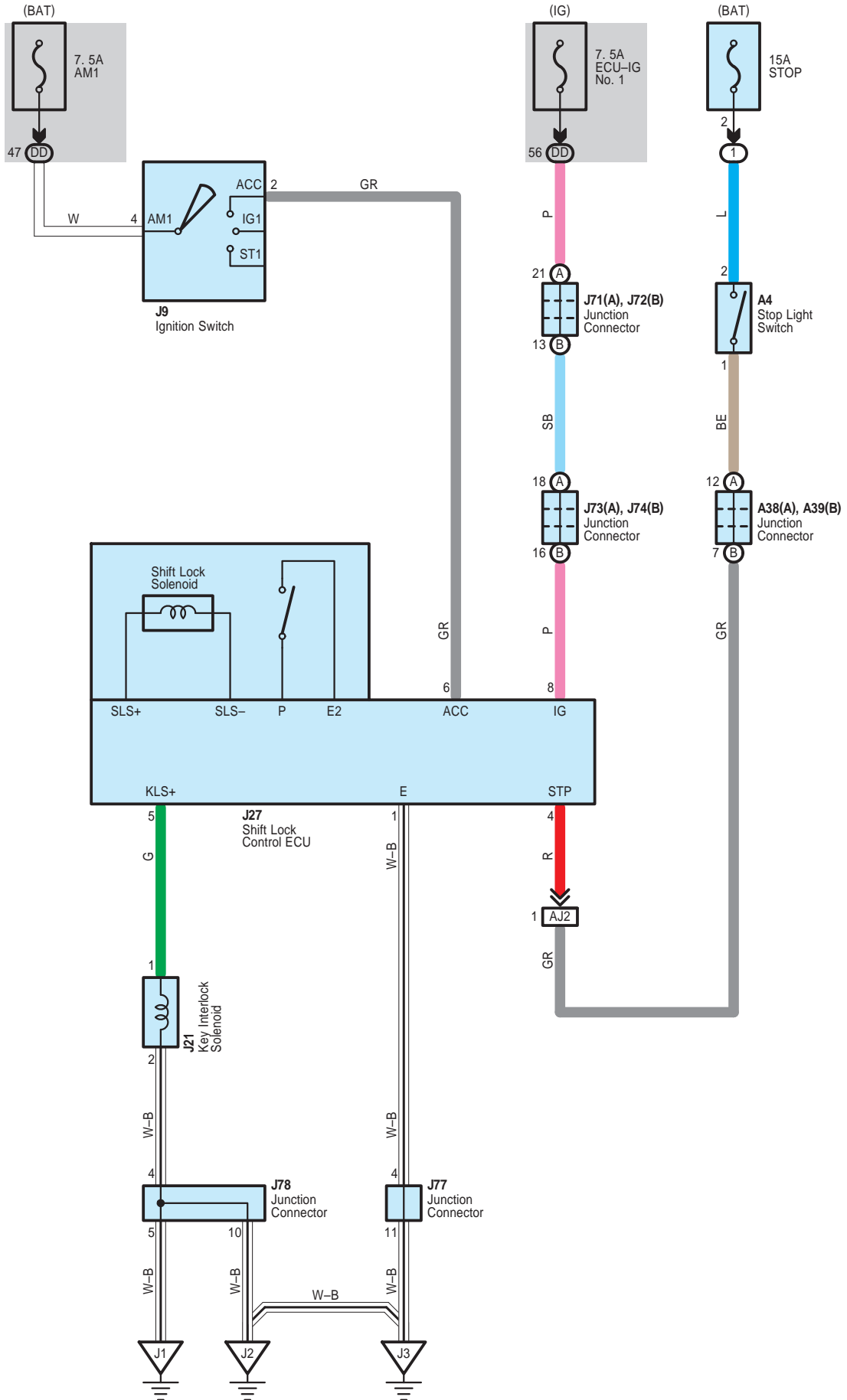

Shift Lock <Floor Shift>

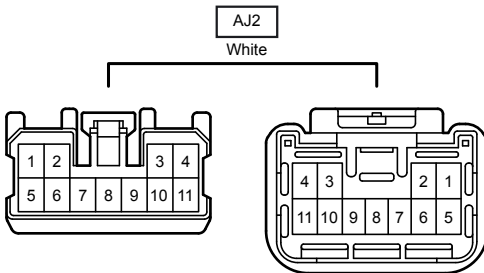
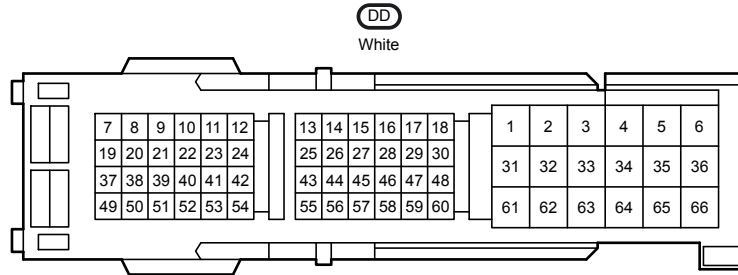
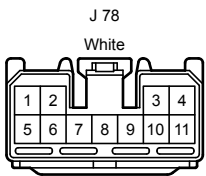
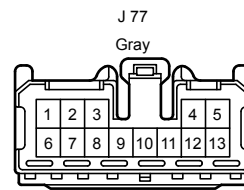
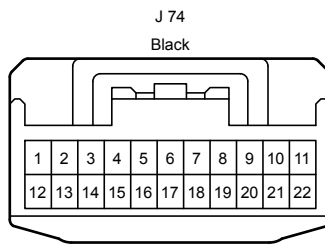
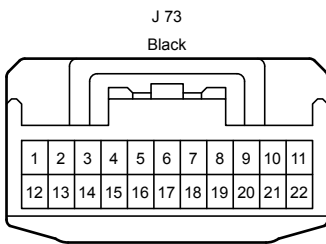
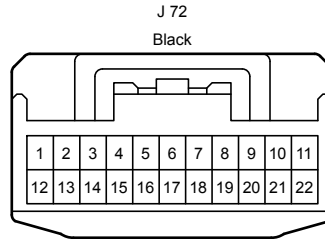
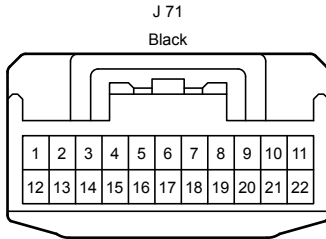
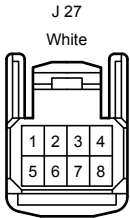
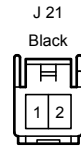
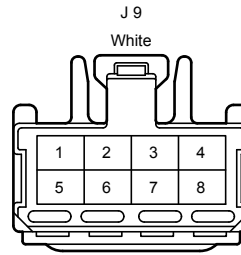
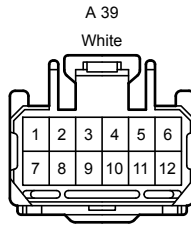
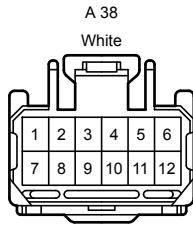
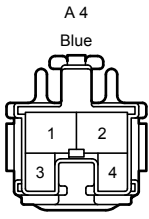

# Sliding Roof

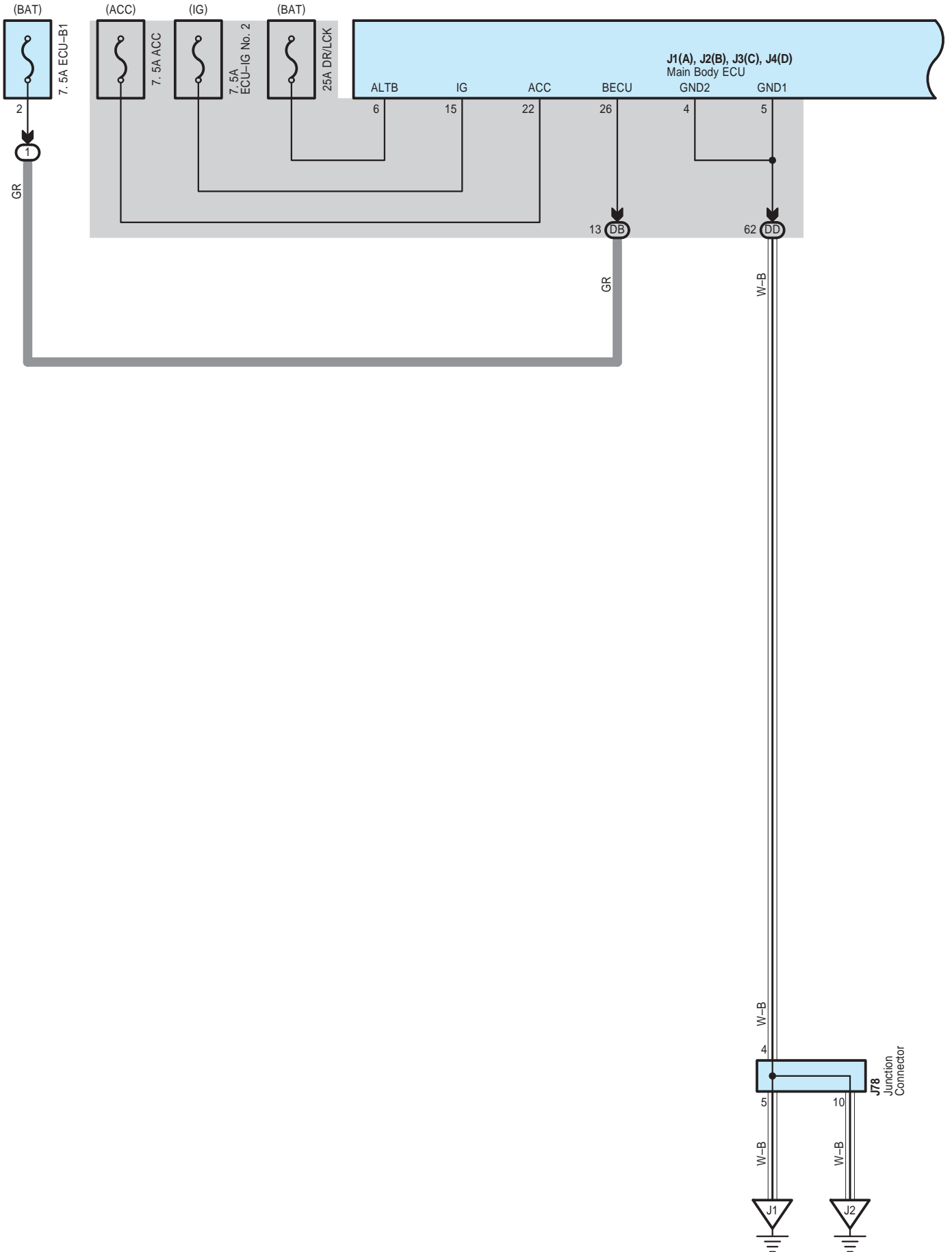

Sliding Roof

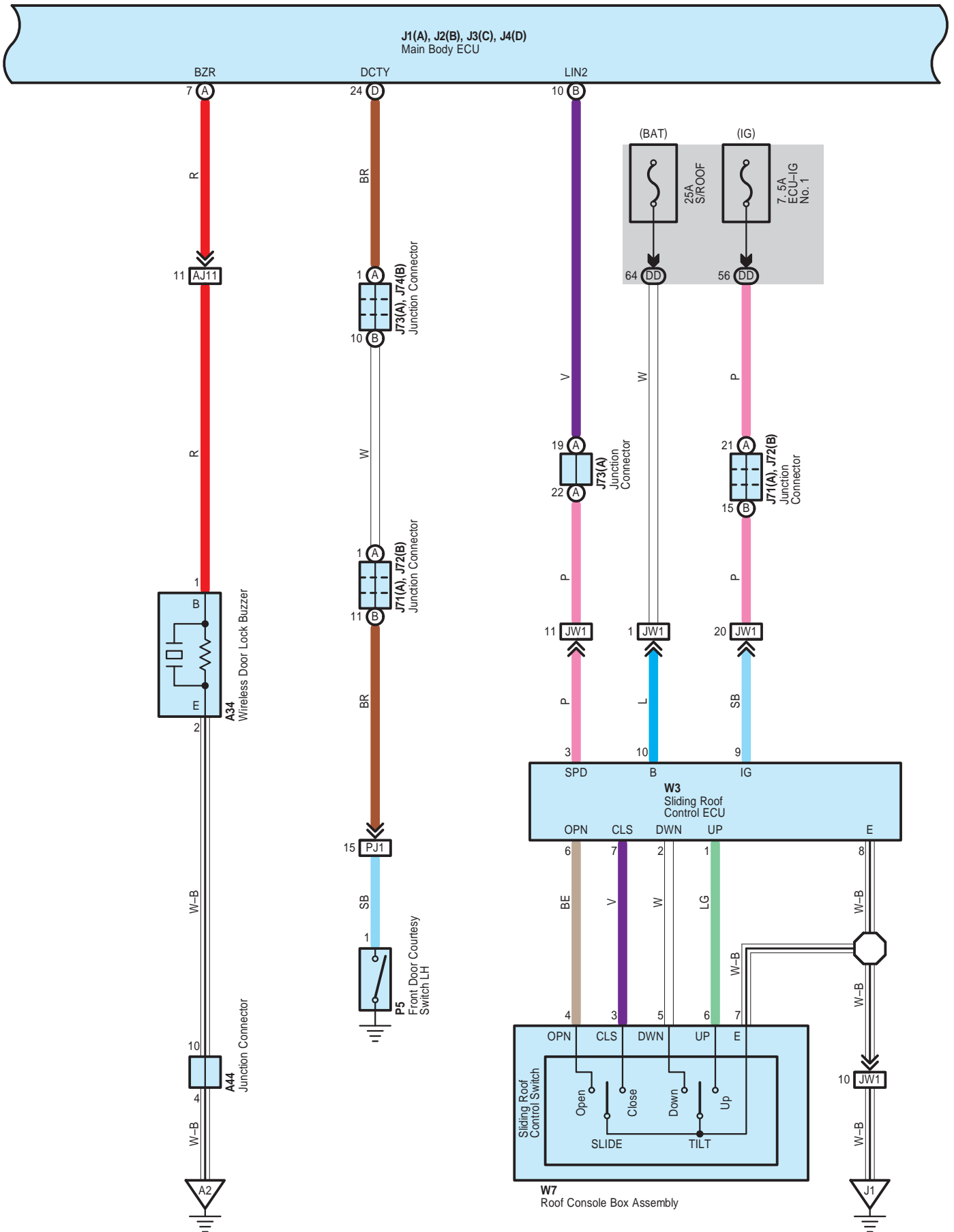



# Sliding Roof

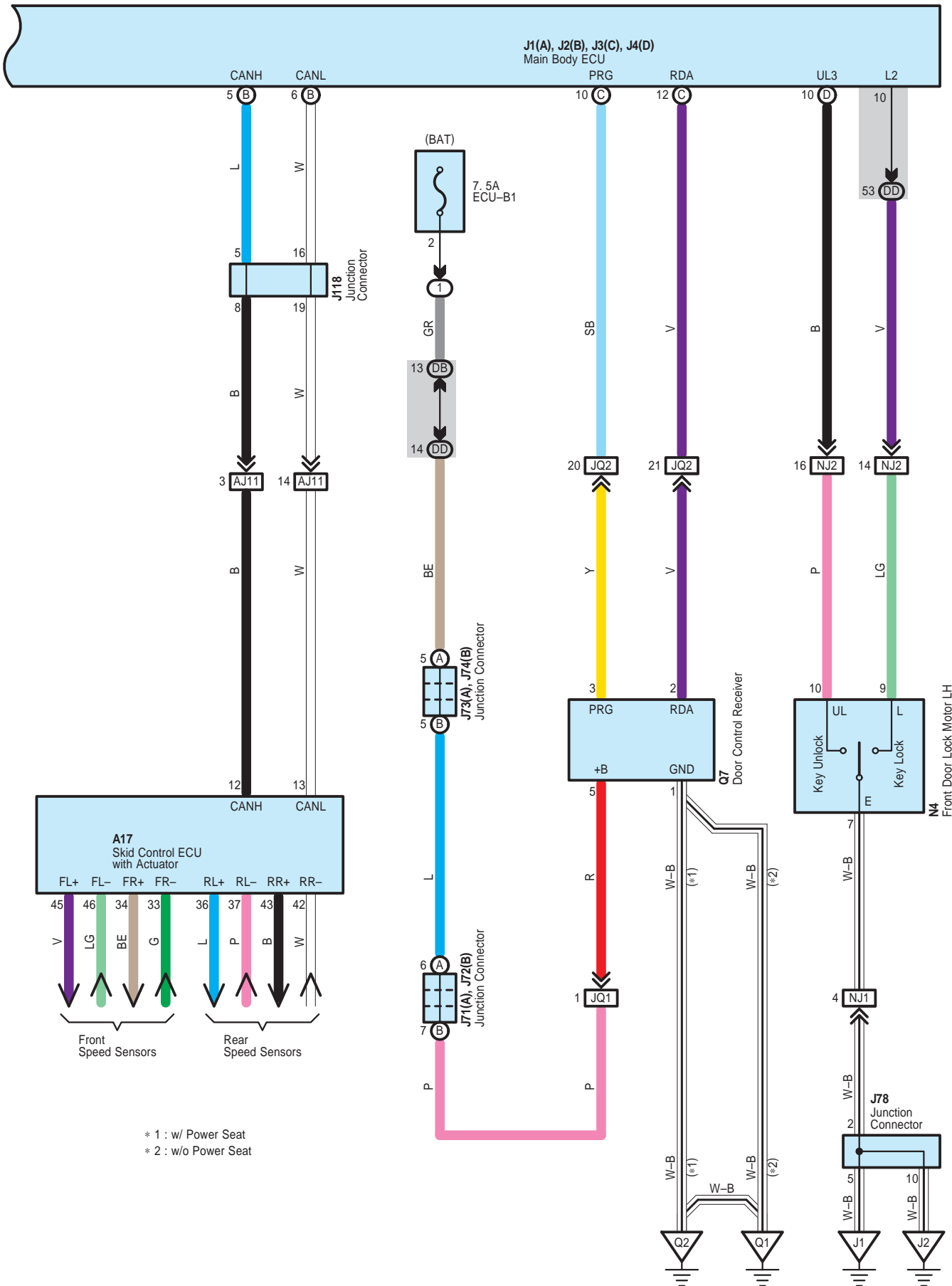

Sliding Roof

A 17  
Black

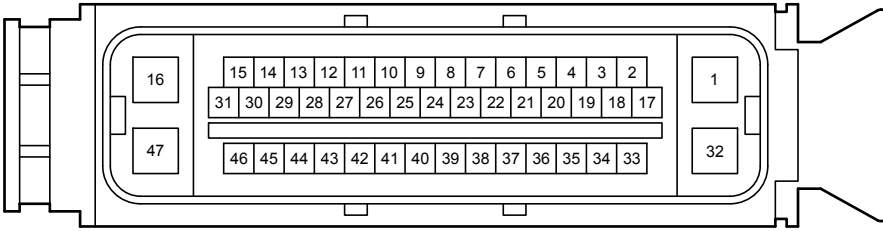

A 34  
Black

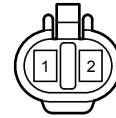

A 44  
White

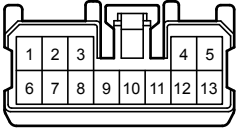

J 1  
White

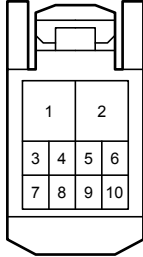

J 2  
White

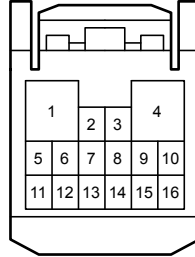

J 3  
White

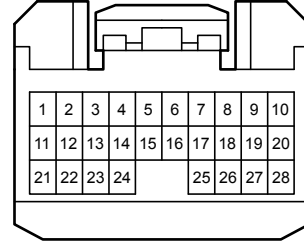

J 4  
White

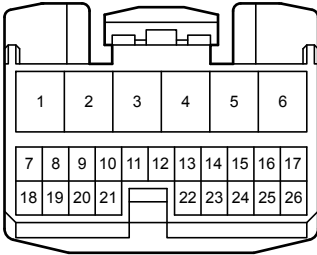

J 71  
Black

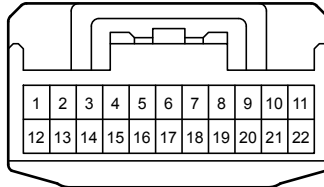

J 72  
Black

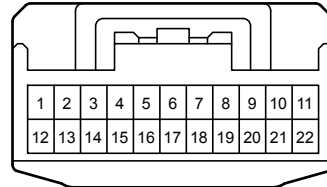

J 73  
Black

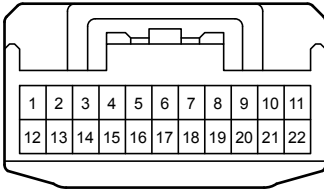

J 74  
Black

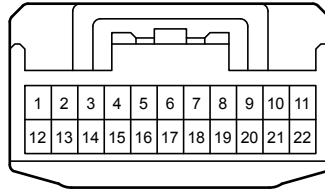

J 78  
White

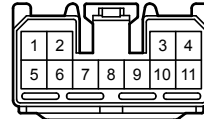

J118  
Gray

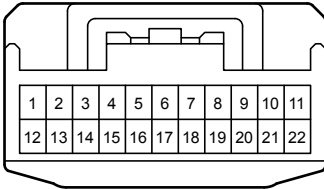

N 4  
White

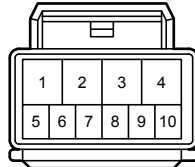

P 5  
White



Q 7  
White

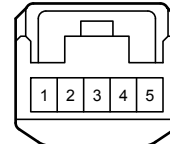

W 3  
White

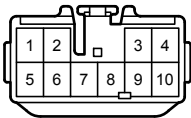

W 7  
White

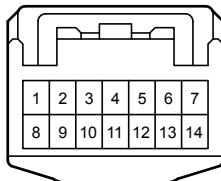

DB  
White

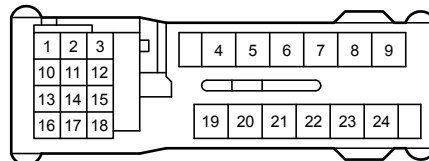

Sliding Roof

DD

White

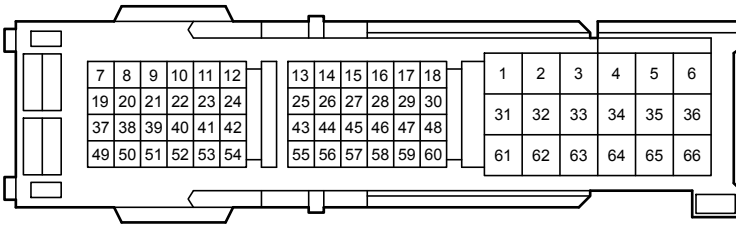

AJ11

Gray

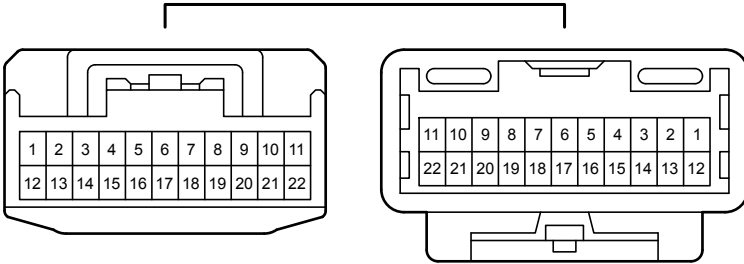

JQ1

Gray

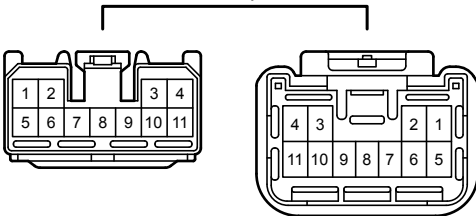

JQ2

Gray

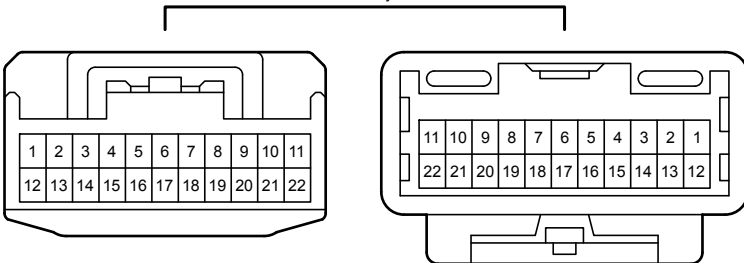

JW1

White

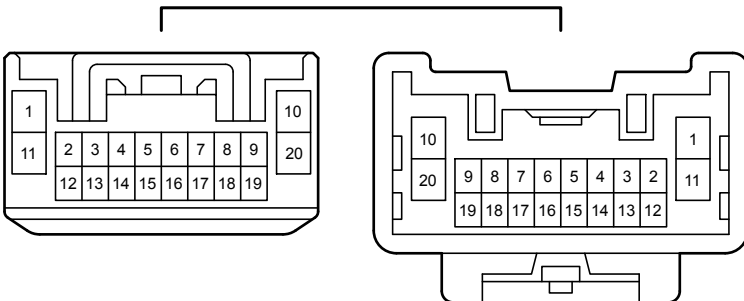

NJ1

Blue

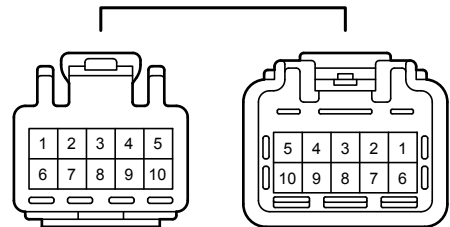

NJ2

Blue

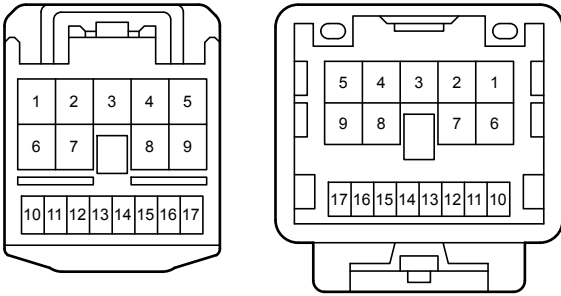

PJ1

Black

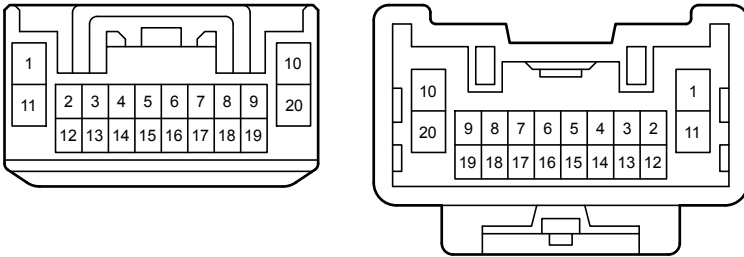

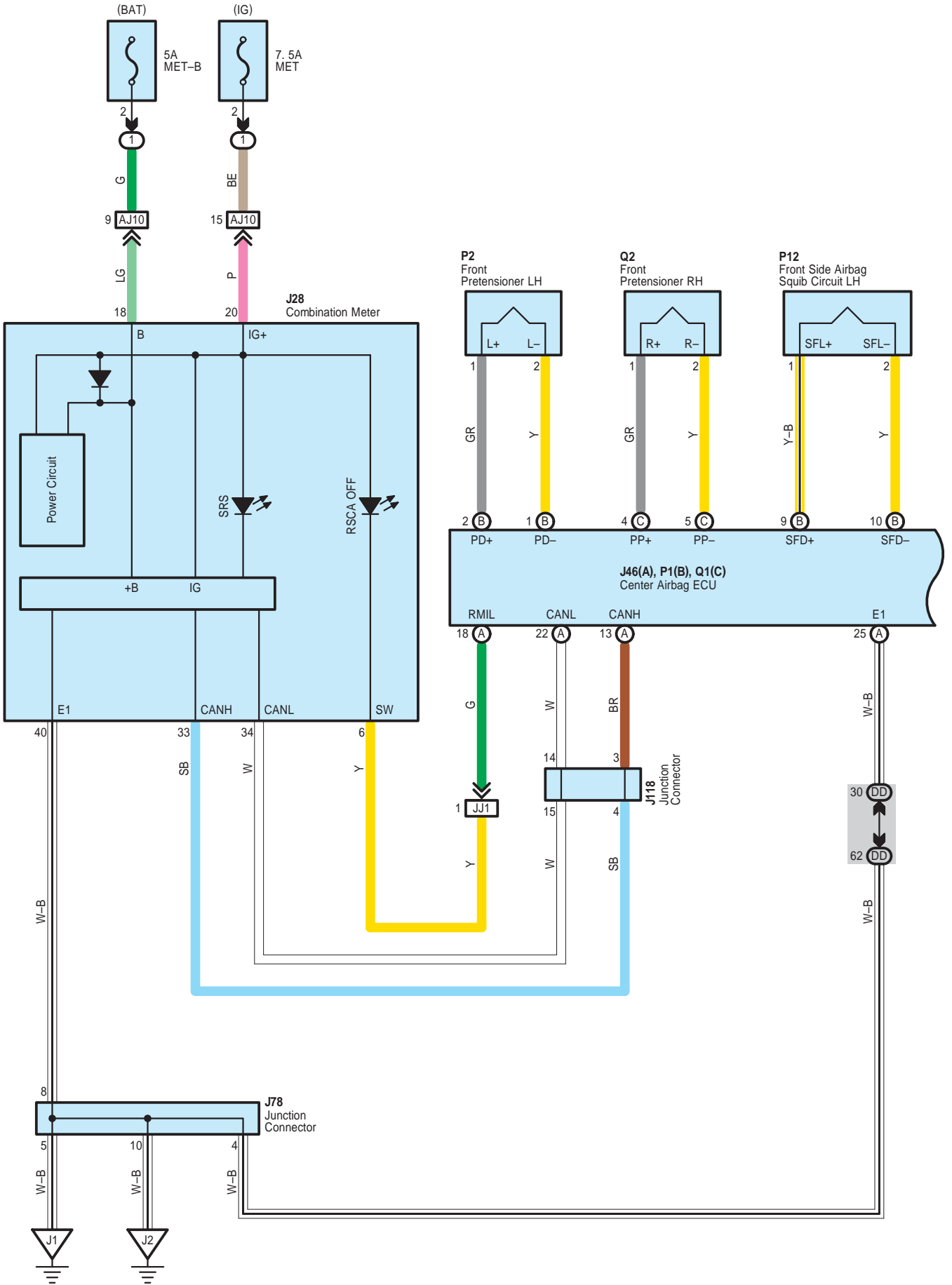

\* 1 : w/ Airbag Cutoff Switch

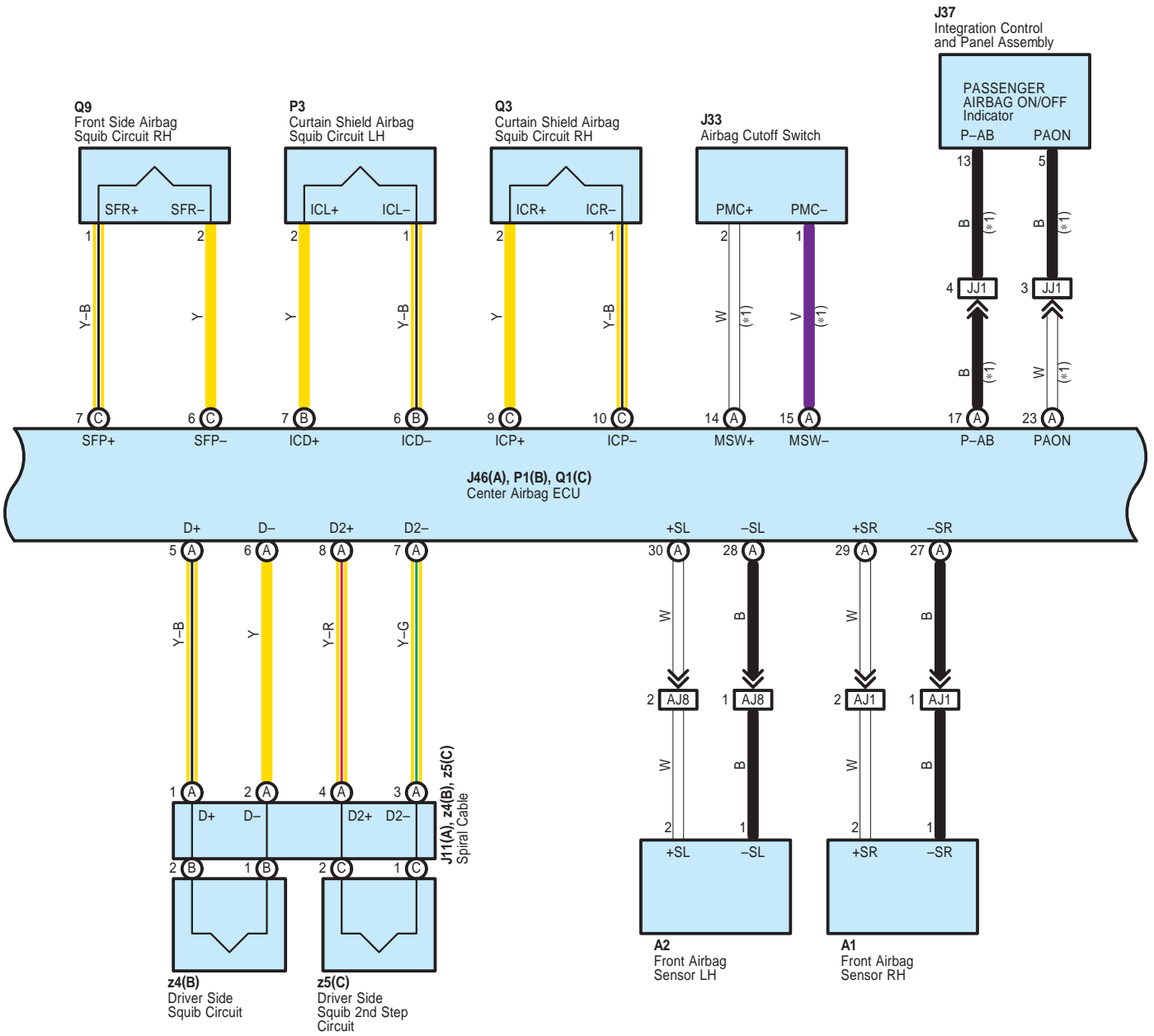

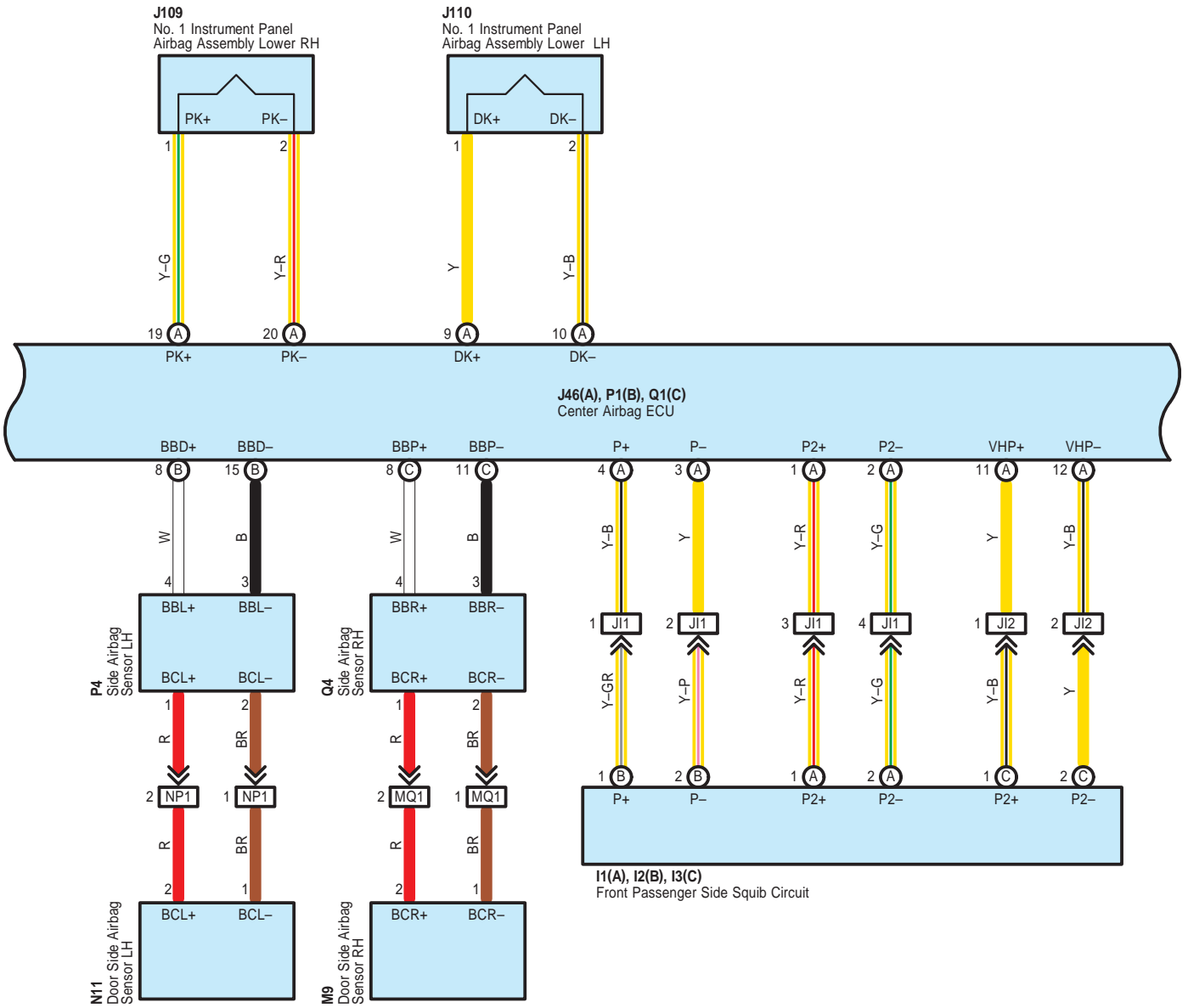

- \* 3 : w/ Power Seat
- \* 4 : w/o Power Seat
- \* 7 : w/ Curtain Airbag Cutoff Switch

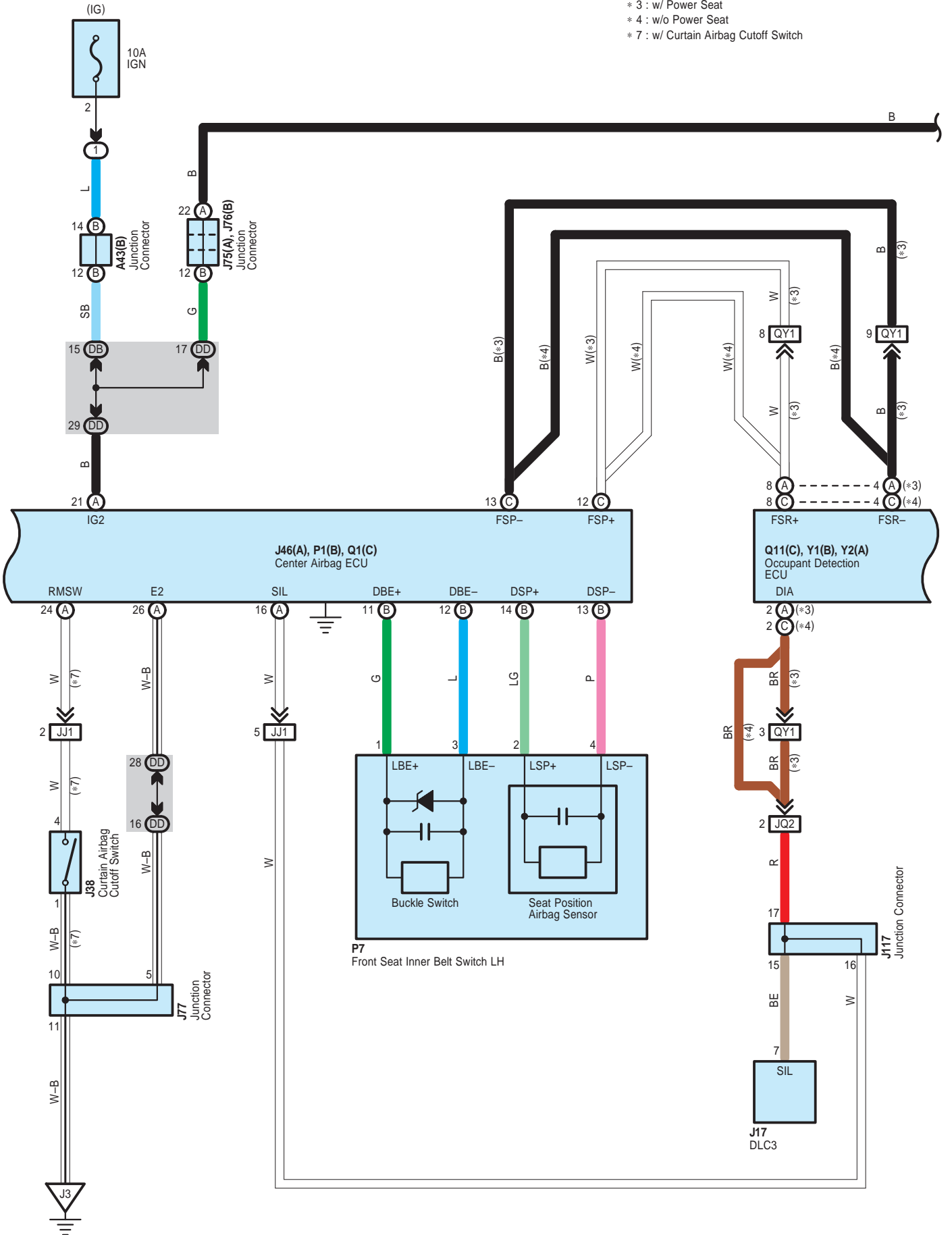



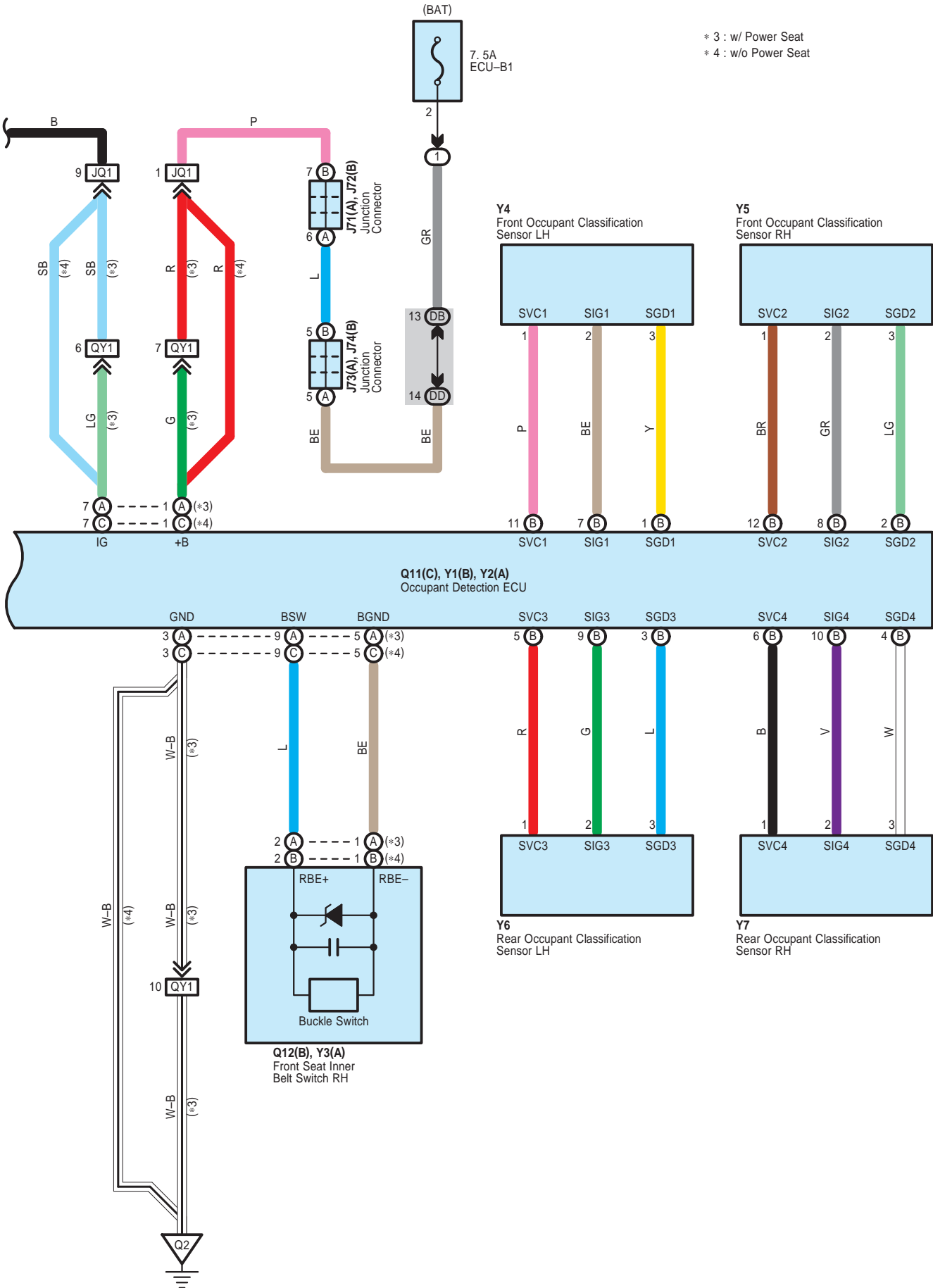

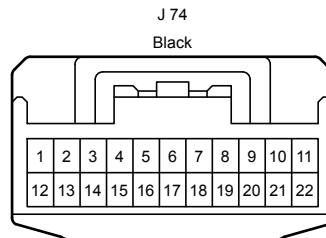
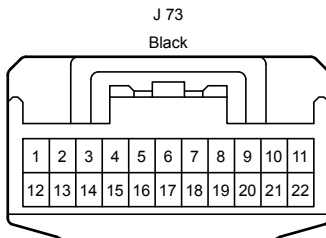
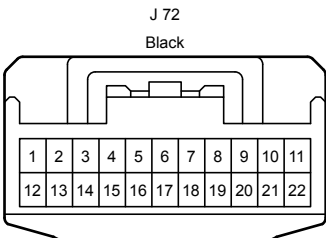
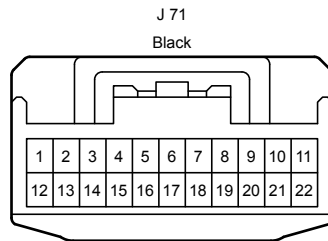
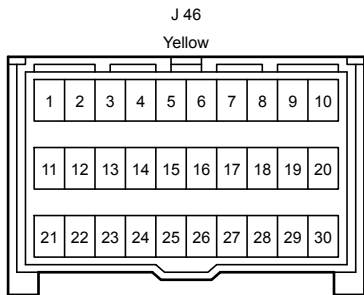
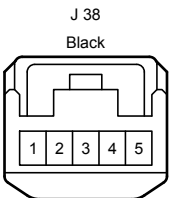
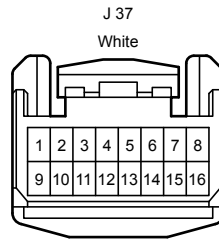
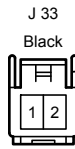
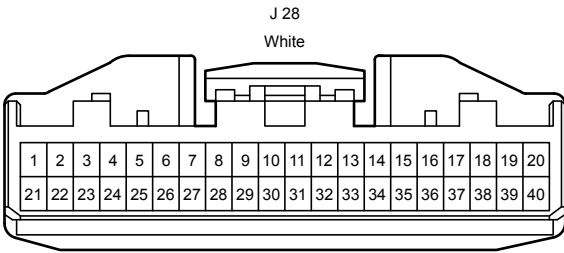
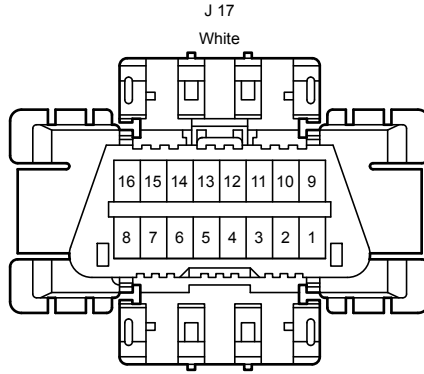
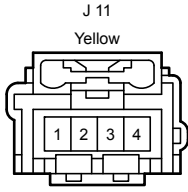
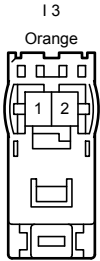
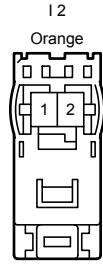
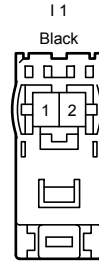
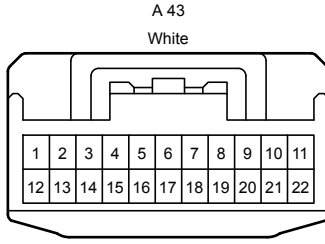
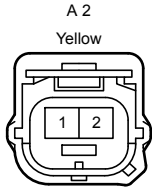
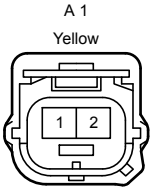

J 75  
White

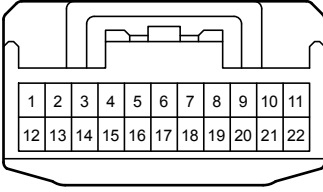

J 76  
White

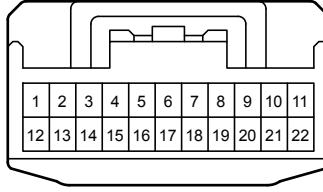

J 77  
Gray

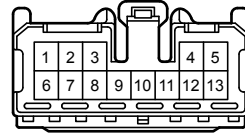

J 78  
White

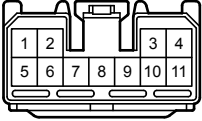

J109  
Yellow

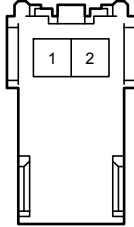

J110  
Yellow

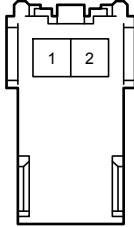

J117  
Black

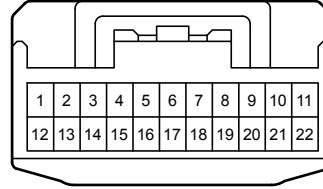

J118  
Gray

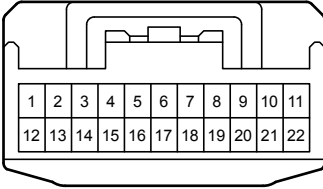

M 9  
Yellow

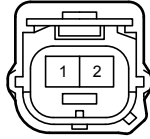

N 11  
Yellow

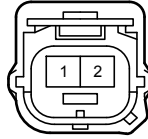

P 1  
Yellow

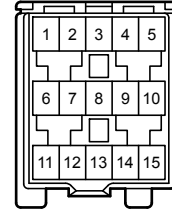

P 2  
Yellow

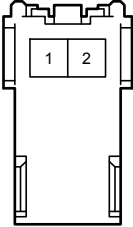

P 3  
Black

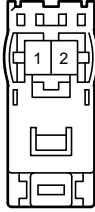

P 4  
Yellow

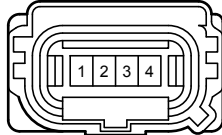

P 7  
White



P 12  
Yellow



Q 1  
Yellow

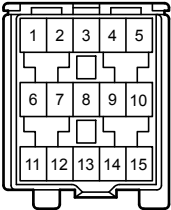

Q 2  
Yellow

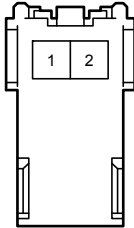

Q 3  
Black

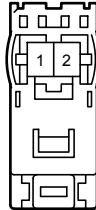

Q 4  
Yellow

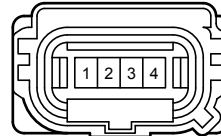

Q 9  
Yellow



Q 11  
Black

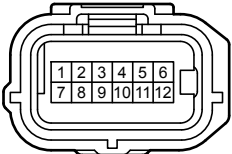

Q 12  
Gray

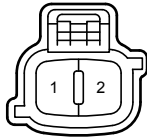

Y 1  
Gray

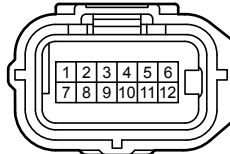

Y 2  
Black

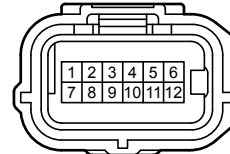

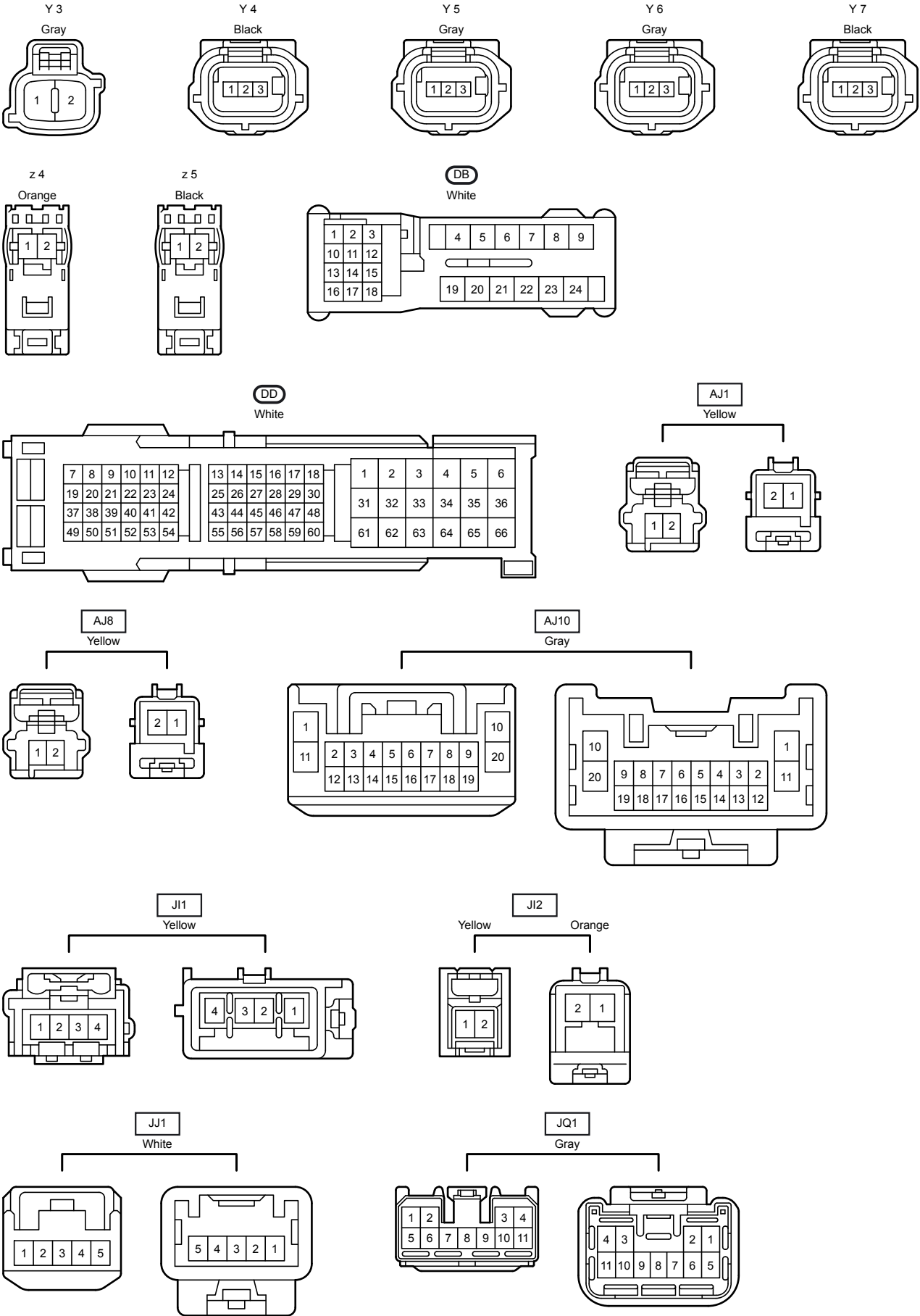

JQ2  
Gray

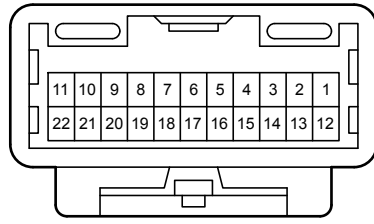
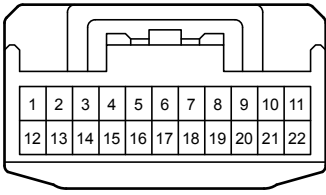

MQ1  
Yellow

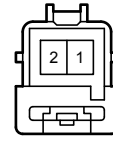
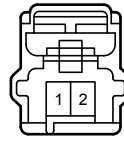

NP1  
Yellow

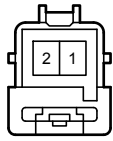
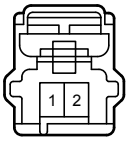

QY1  
White

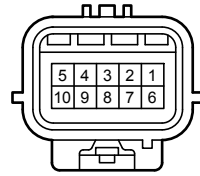
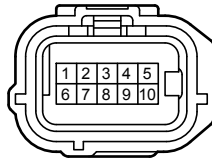

# Starting

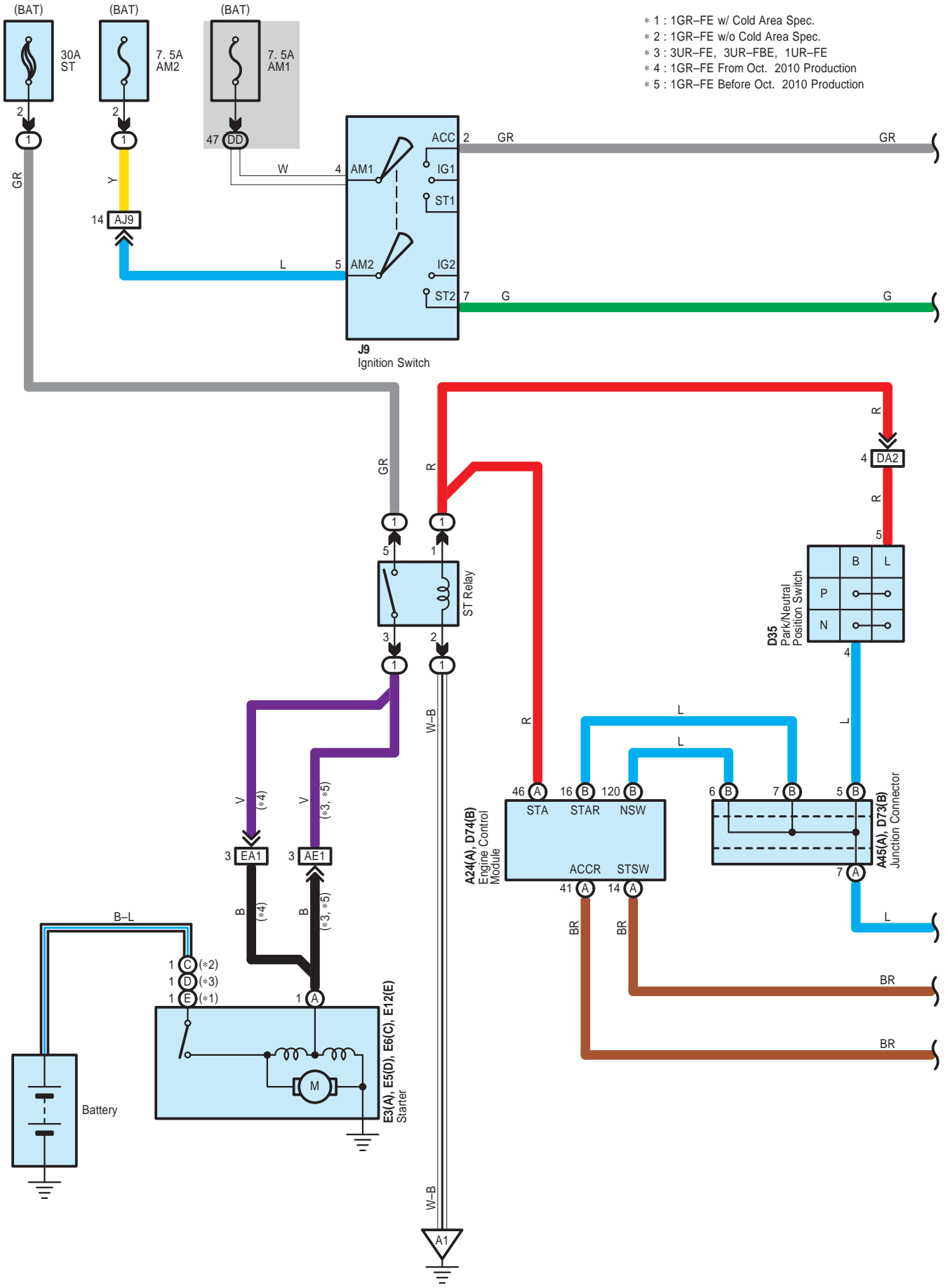

- \* 1 : 1GR-FE w/ Cold Area Spec.
- \* 2 : 1GR-FE w/o Cold Area Spec.
- \* 3 : 3UR-FE, 3UR-FBE, 1UR-FE
- \* 4 : 1GR-FE From Oct. 2010 Production
- \* 5 : 1GR-FE Before Oct. 2010 Production

Starting

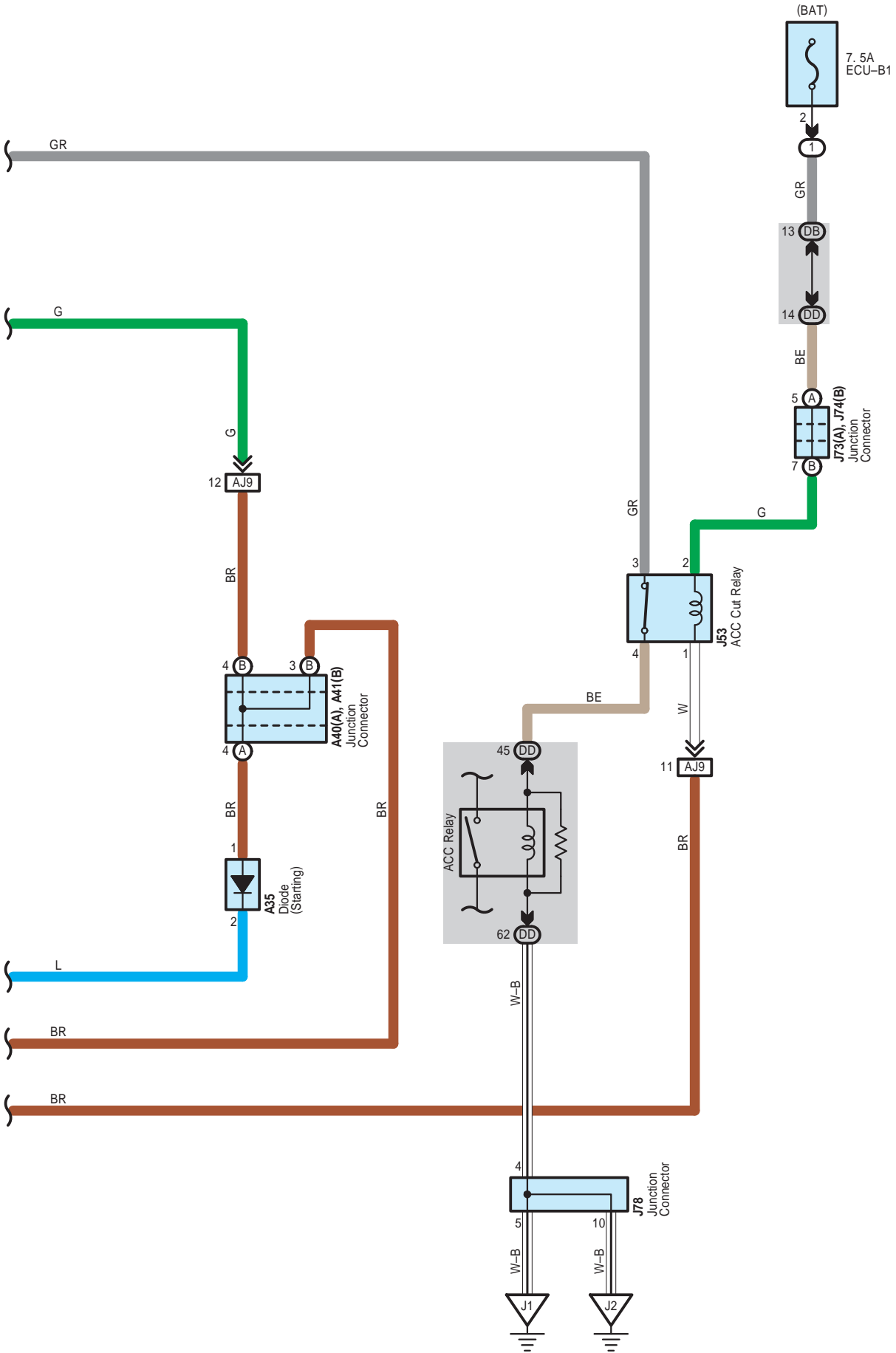





Starting

J 73  
Black

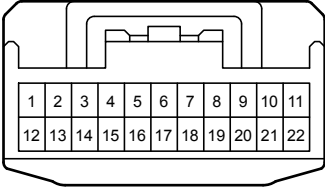

J 74  
Black

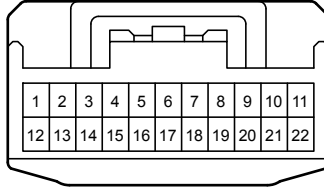

J 78  
White

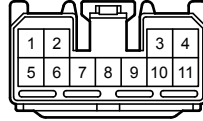

DB  
White

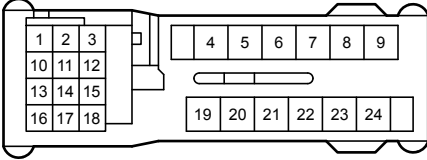

DD  
White

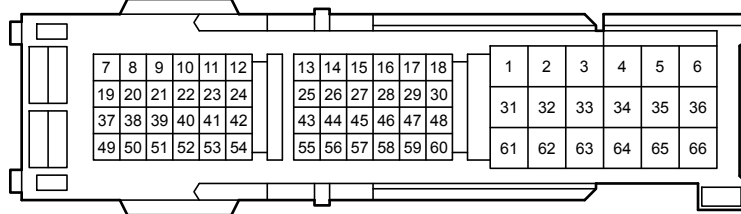

AE1  
Gray

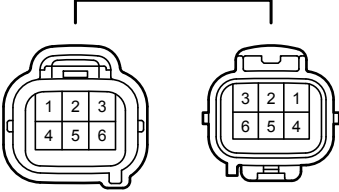

AJ9  
Gray

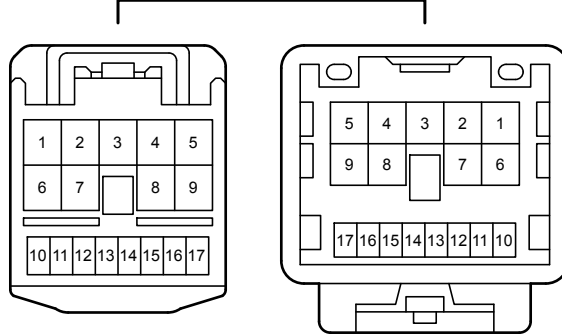

DA2  
White

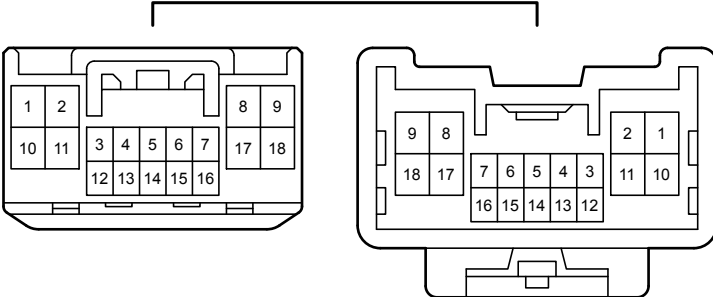

EA1  
Gray

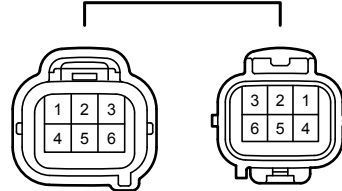

# Theft Deterrent

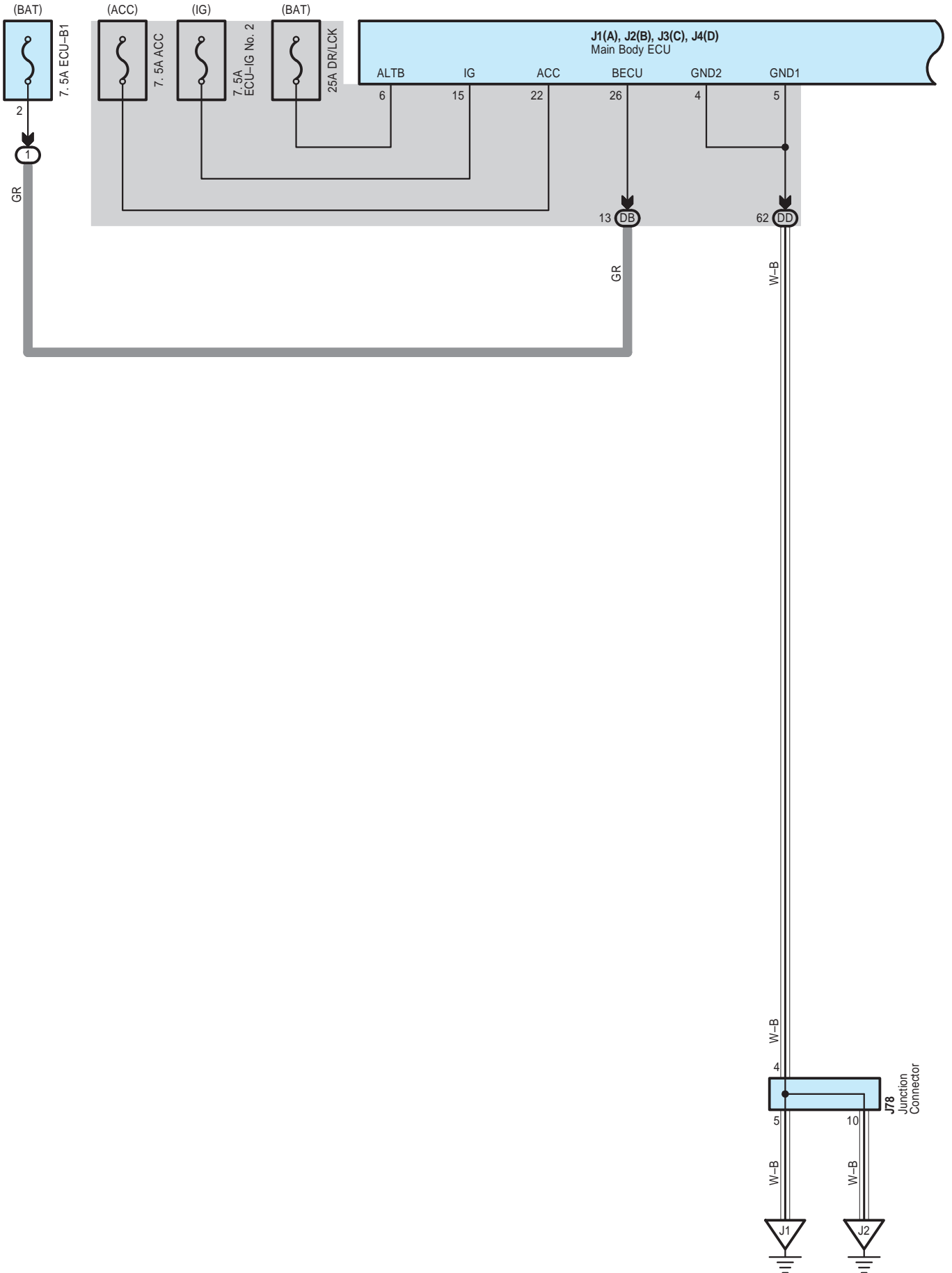

Theft Deterrent

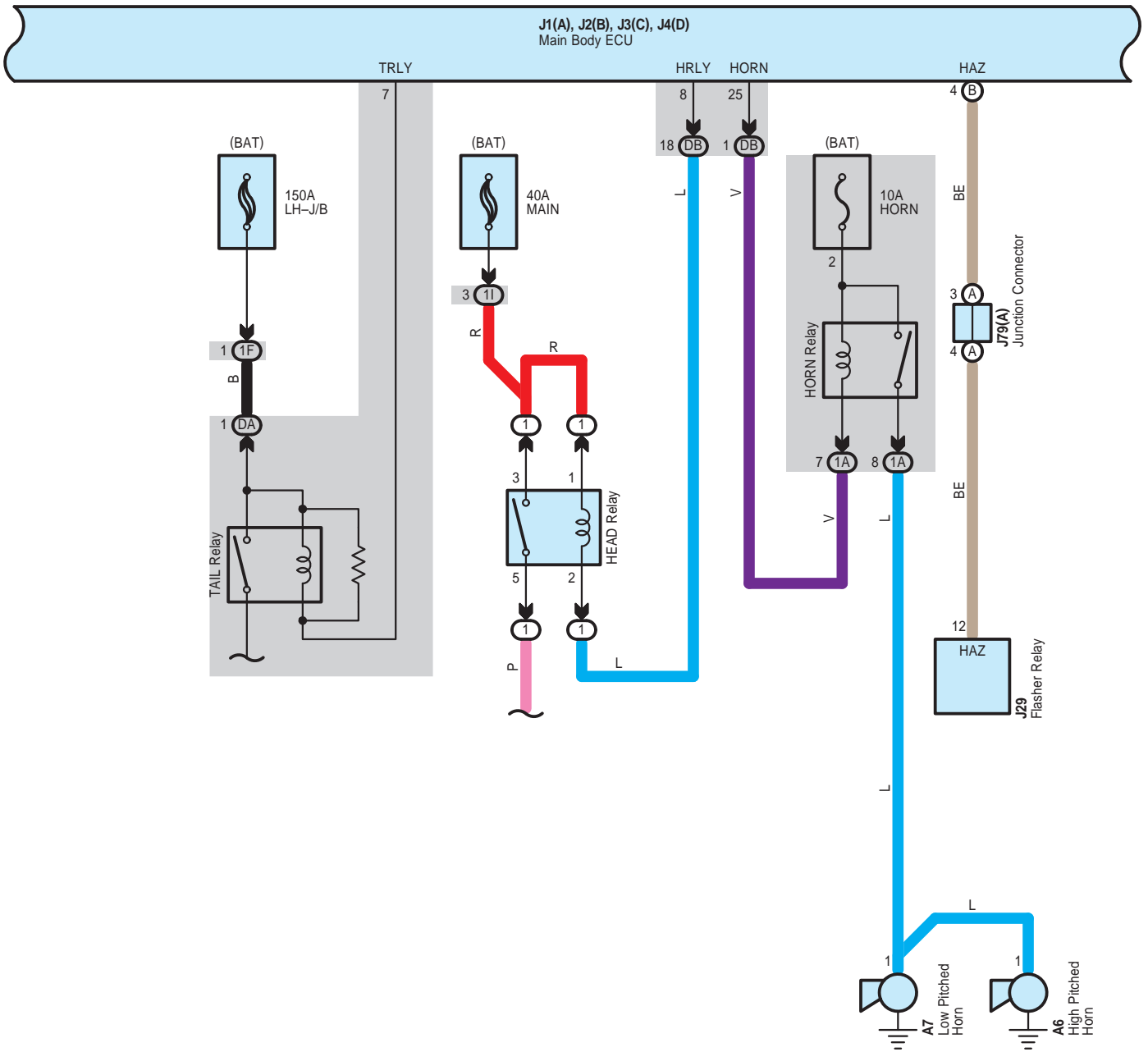

Theft Deterrent

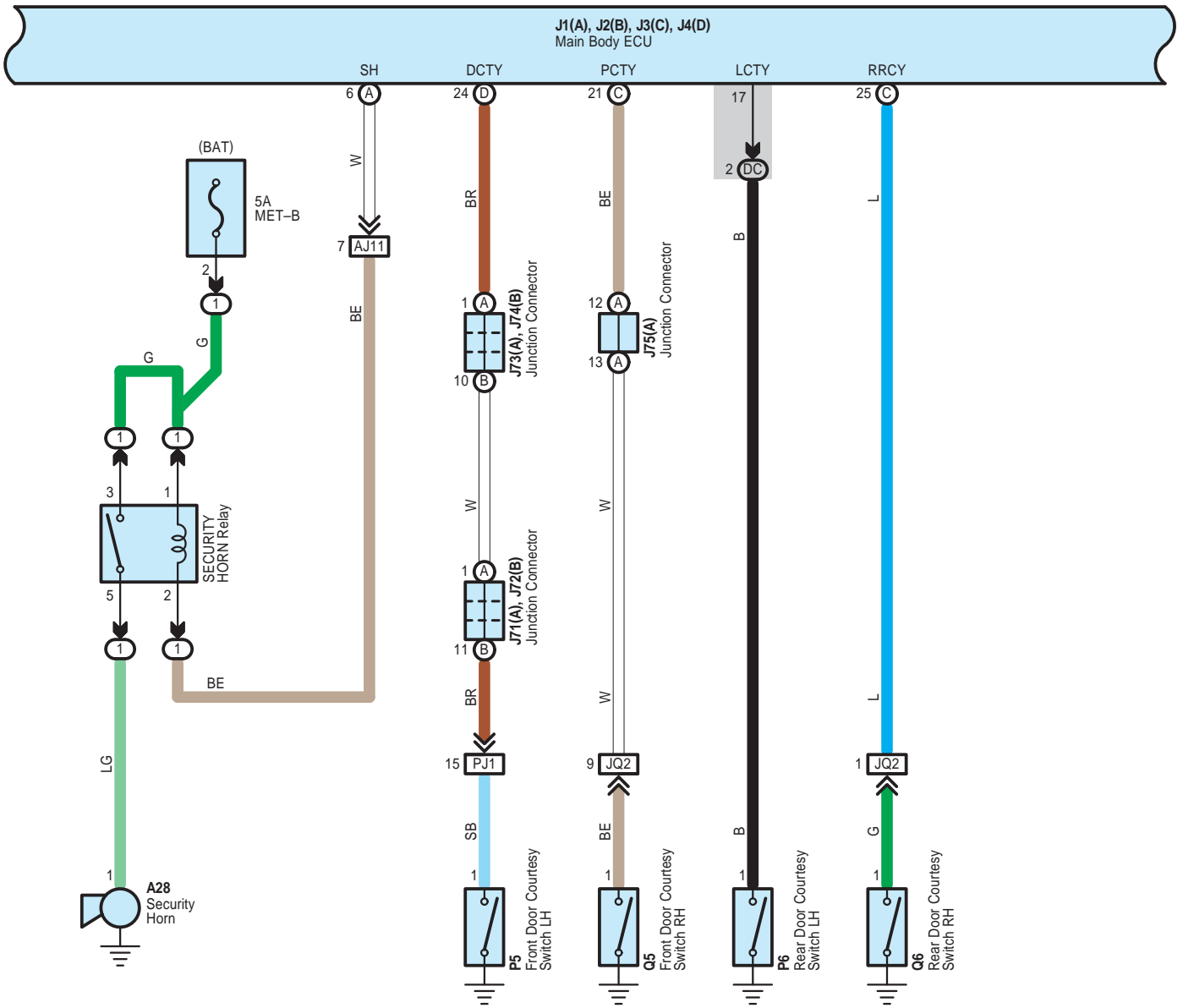

Theft Deterrent

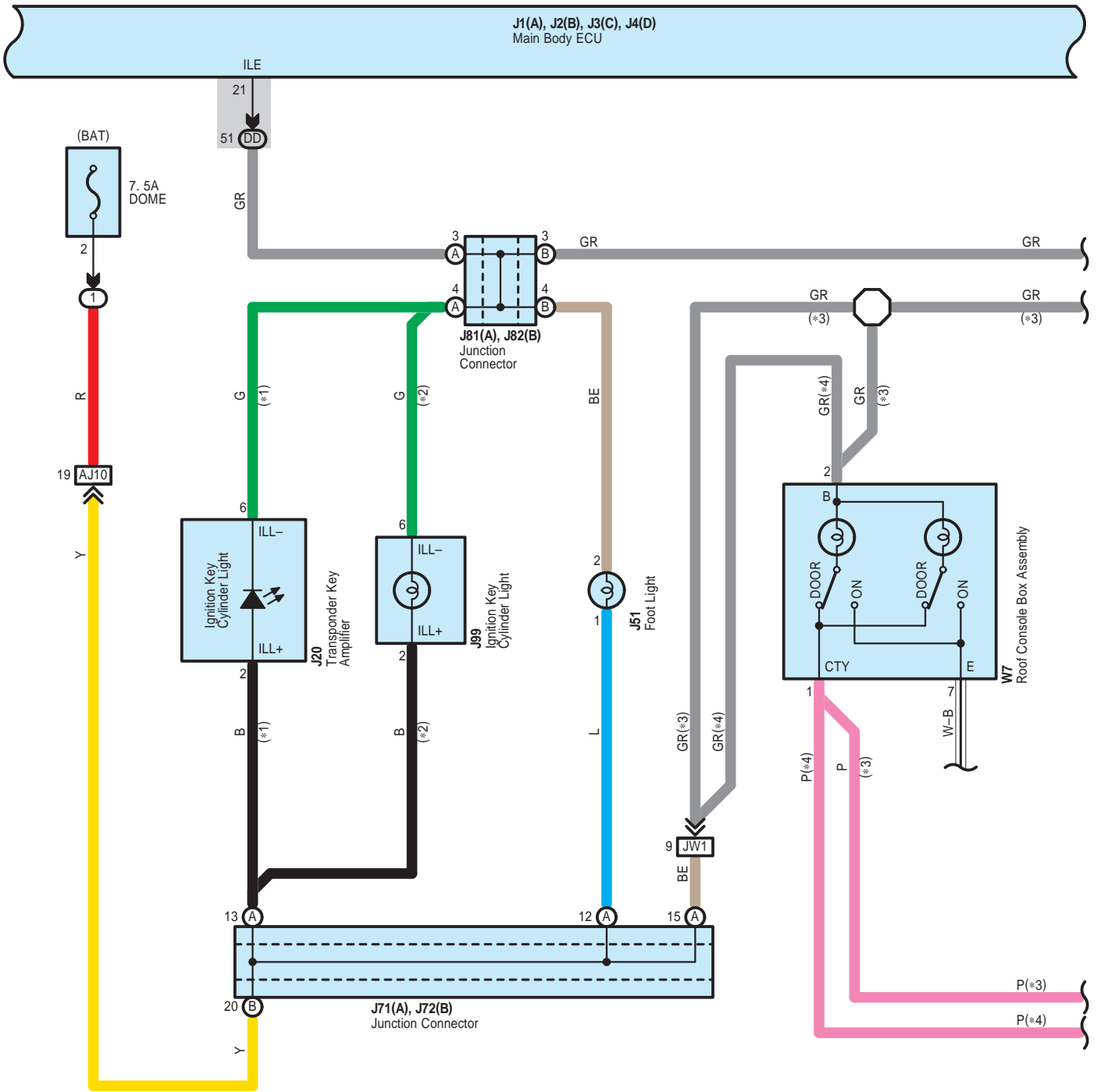

- \* 1 : w/ Engine Immobiliser System
- \* 2 : w/o Engine Immobiliser System
- \* 3 : Except Regular Cab
- \* 4 : Regular Cab

# Theft Deterrent

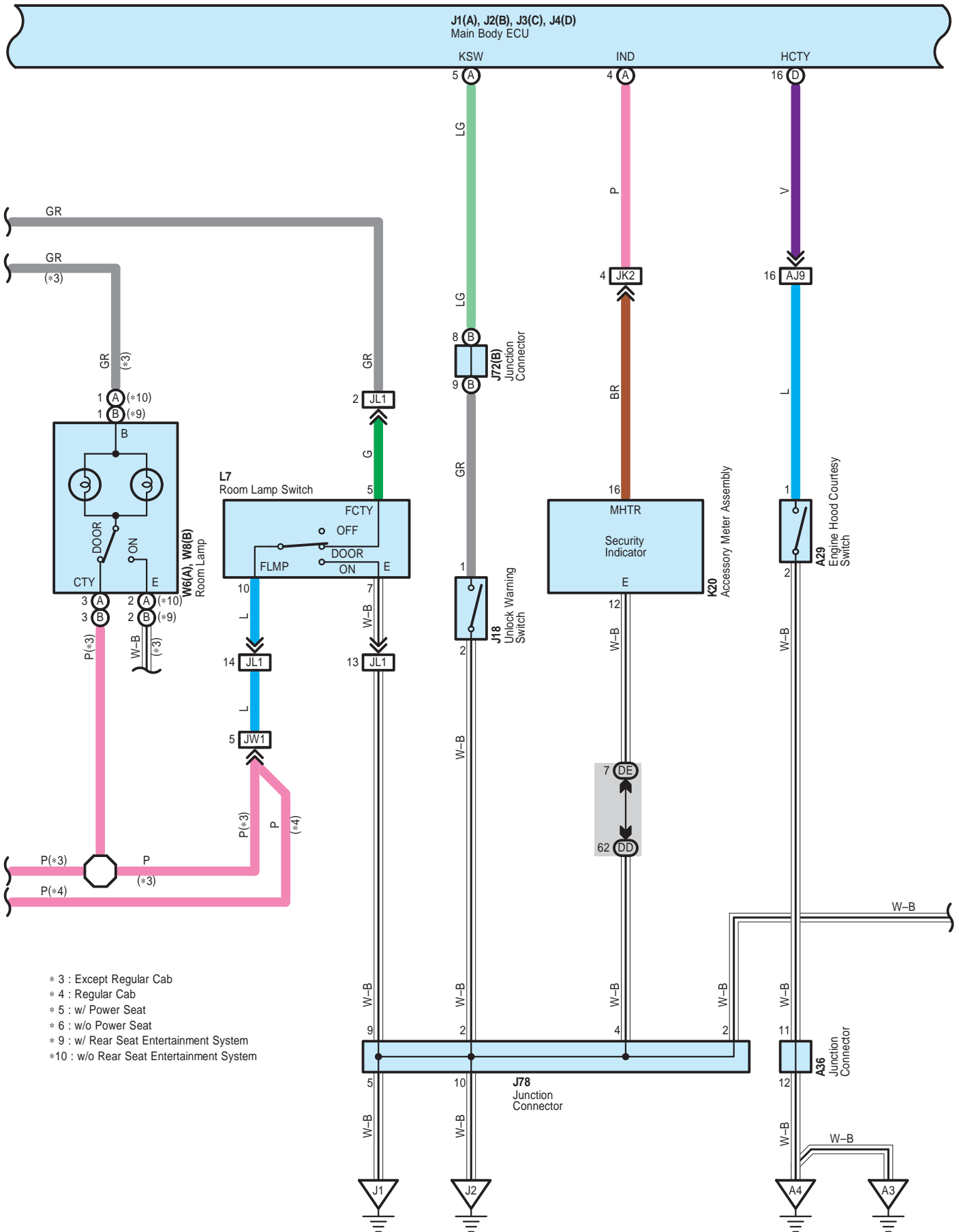

- \* 3 : Except Regular Cab
- \* 4 : Regular Cab
- \* 5 : w/ Power Seat
- \* 6 : w/o Power Seat
- \* 9 : w/ Rear Seat Entertainment System
- \* 10 : w/o Rear Seat Entertainment System

Theft Deterrent

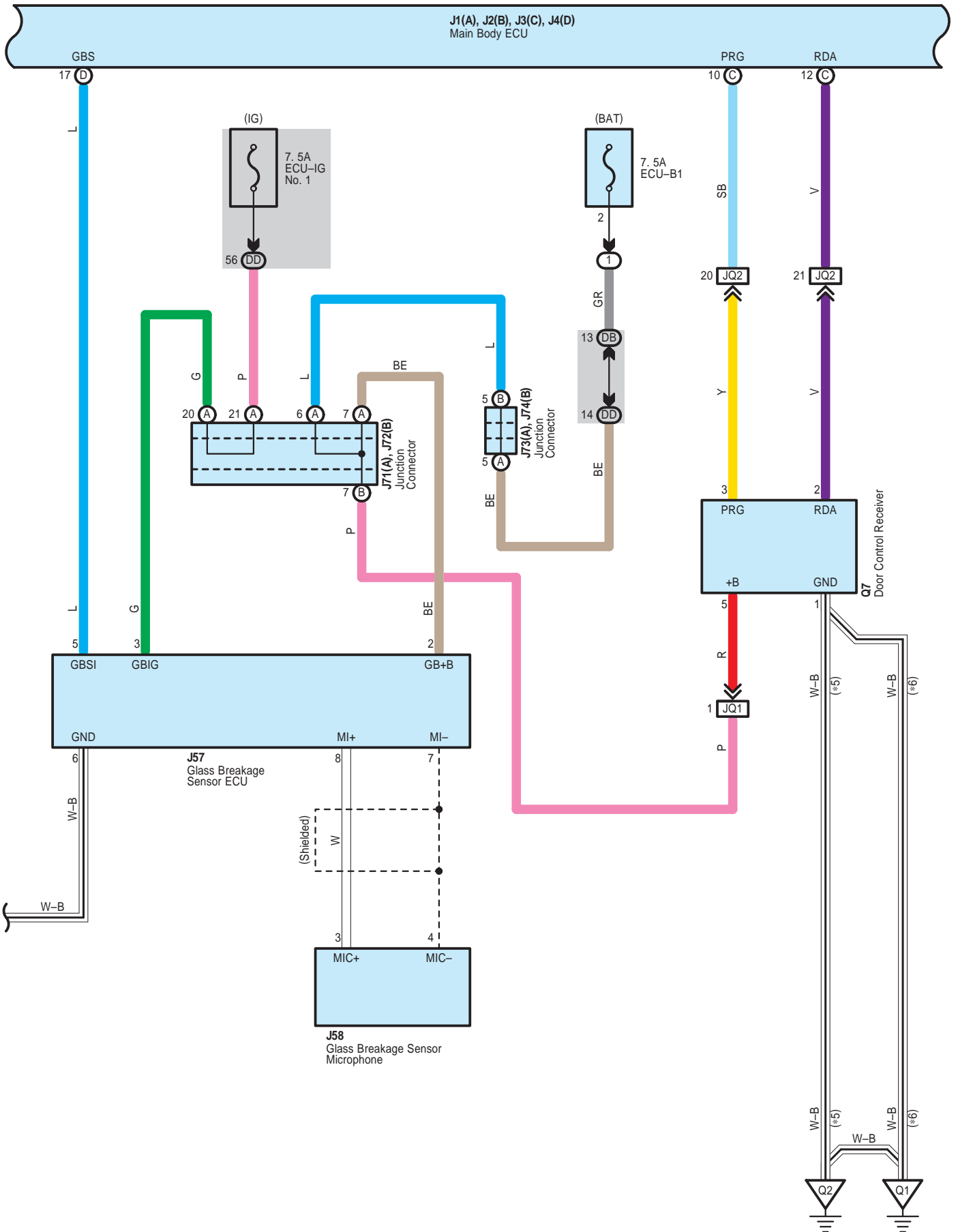

Theft Deterrent

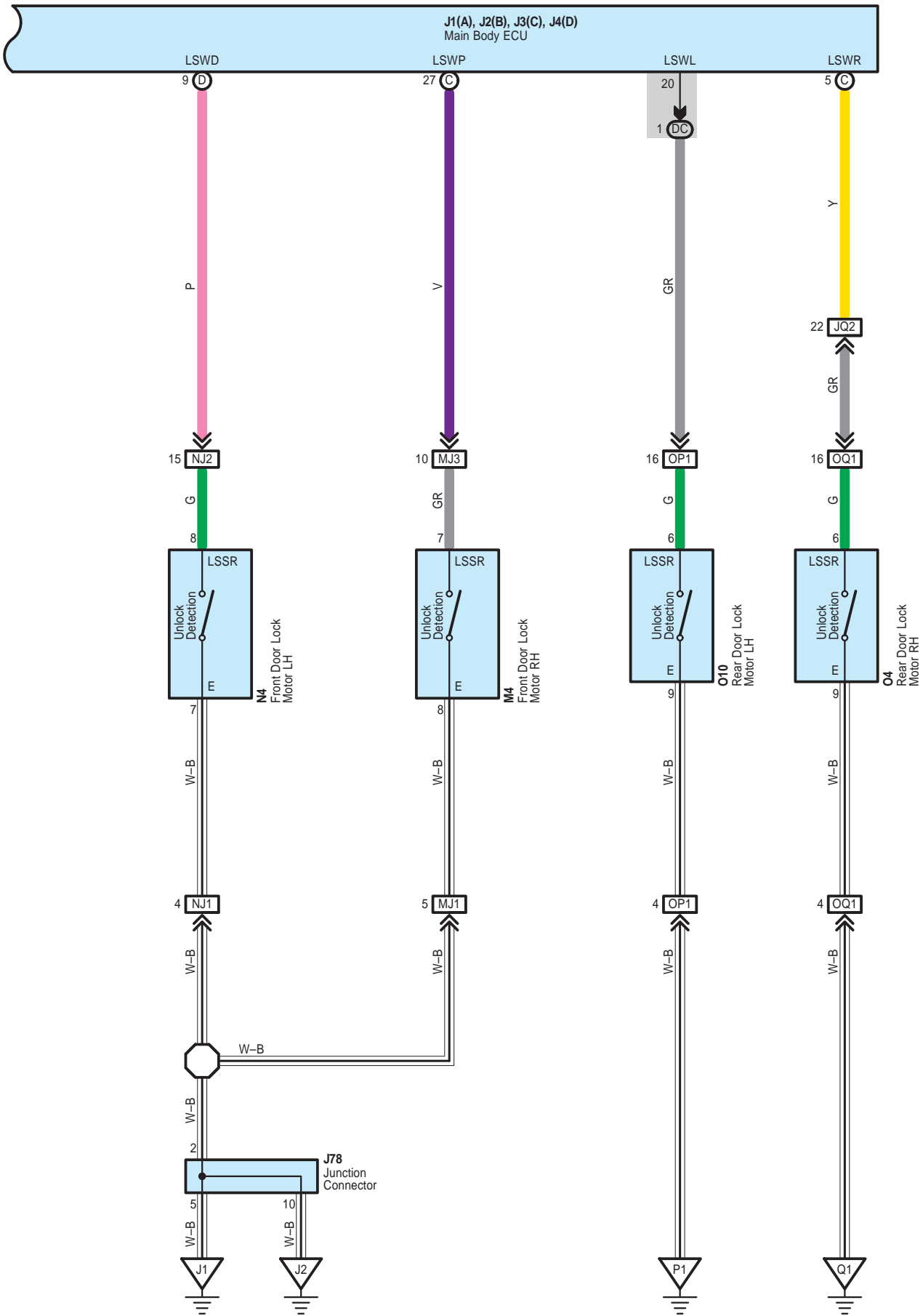



Theft Deterrent

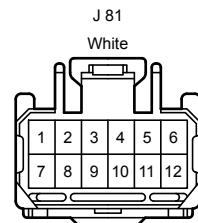
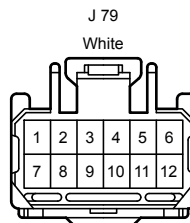
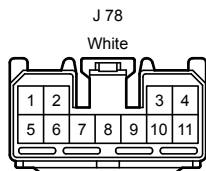
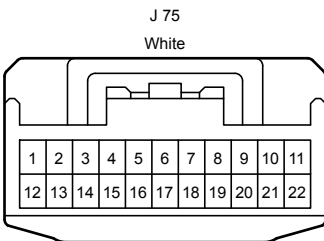
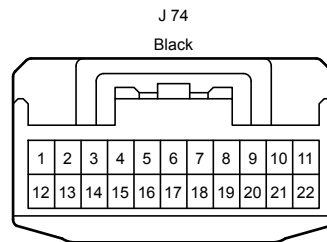
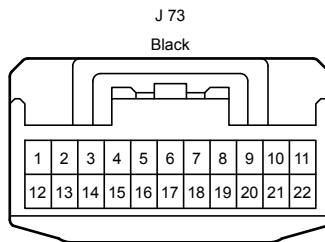
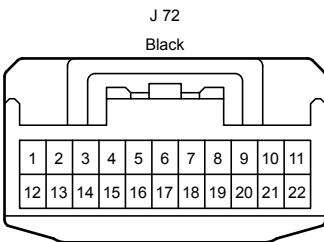
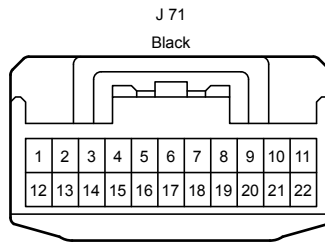
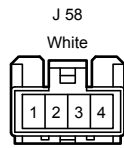
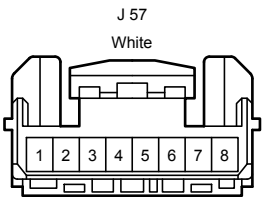
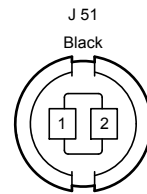
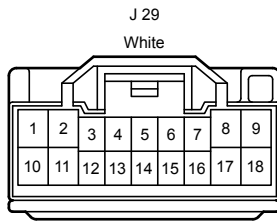
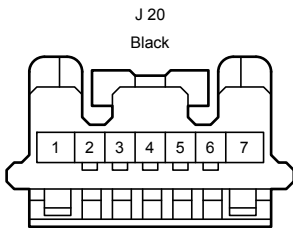
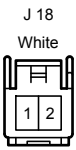
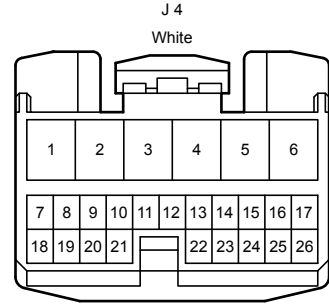
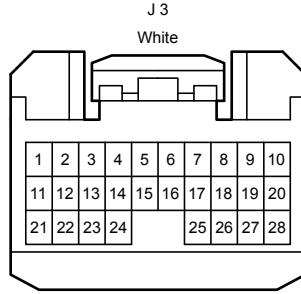
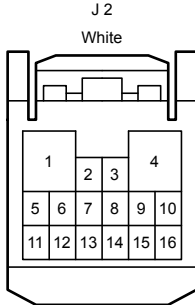
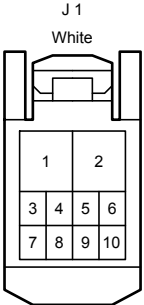
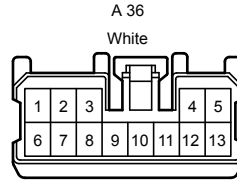
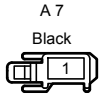
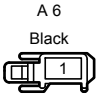

Theft Deterrent

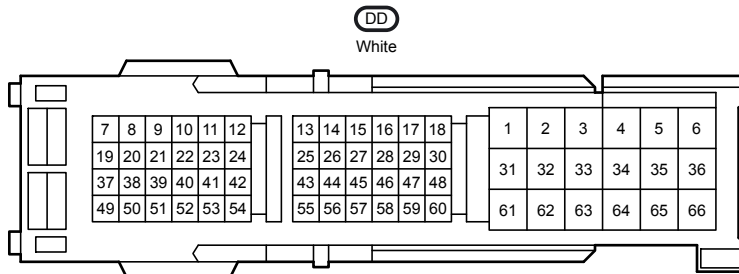
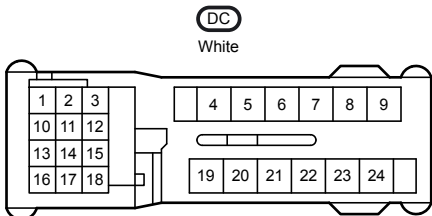
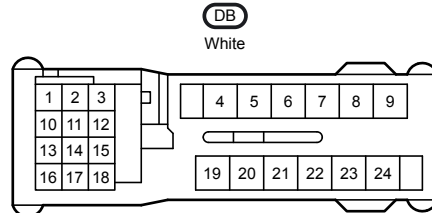
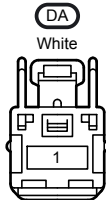
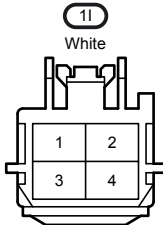
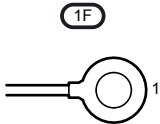
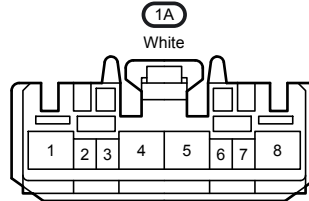
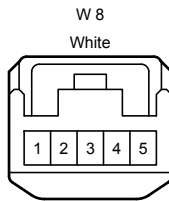
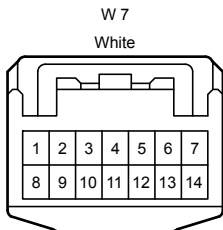
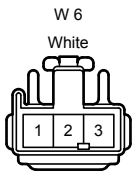
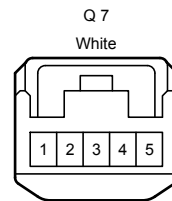
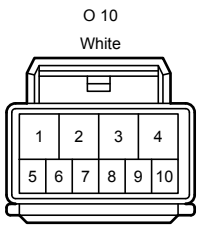
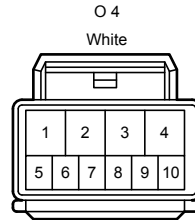
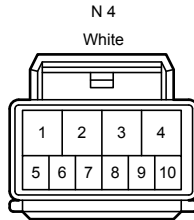
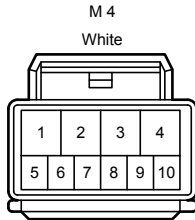
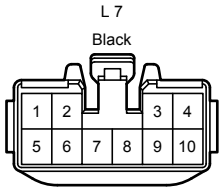
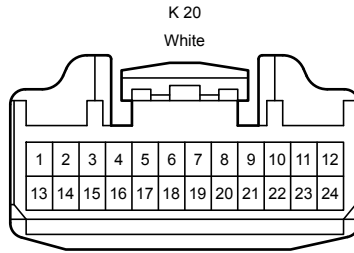
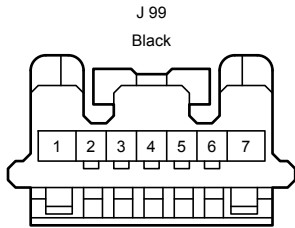
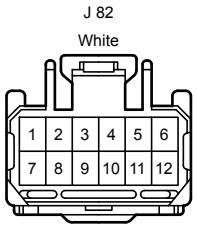

Theft Deterrent

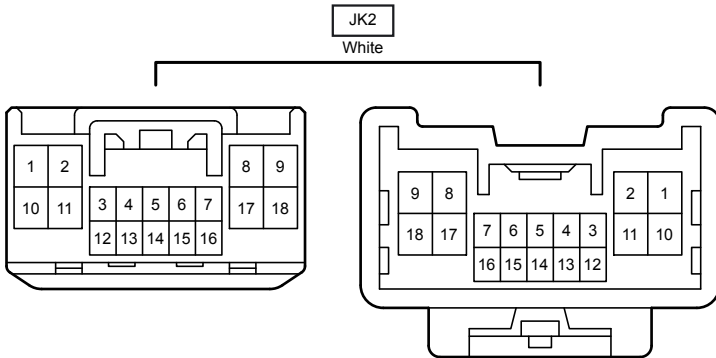
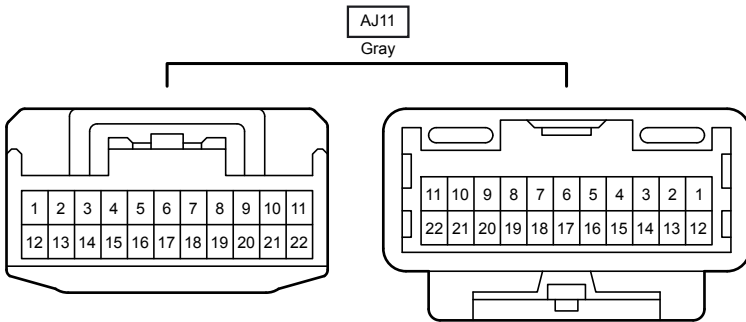
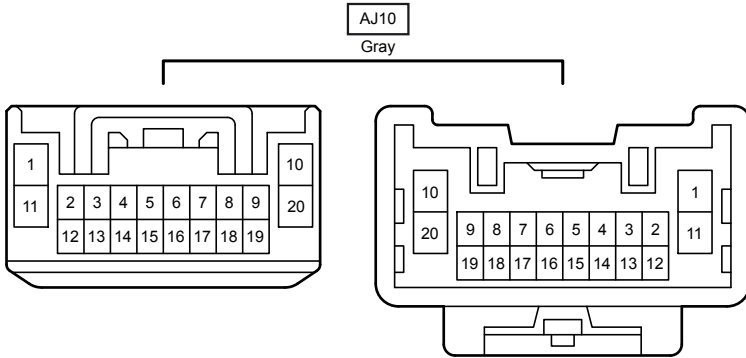
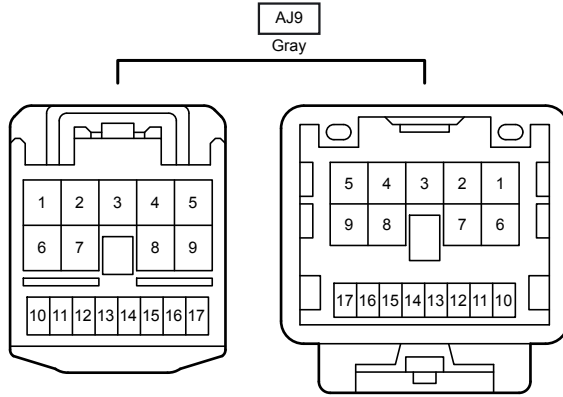
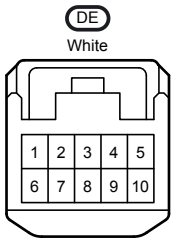

JL1  
White

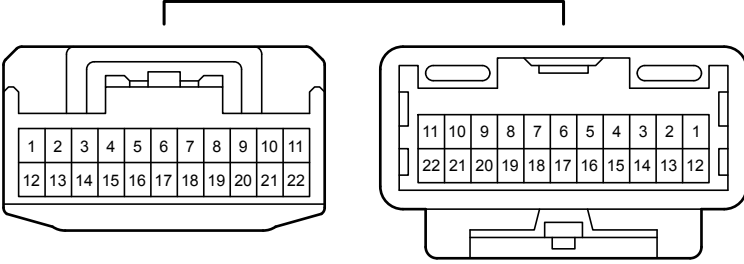

JQ1  
Gray

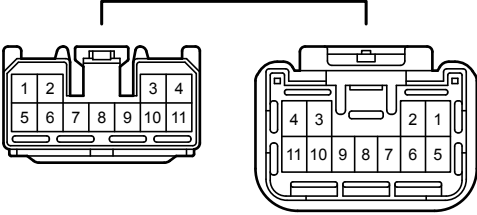

JQ2  
Gray

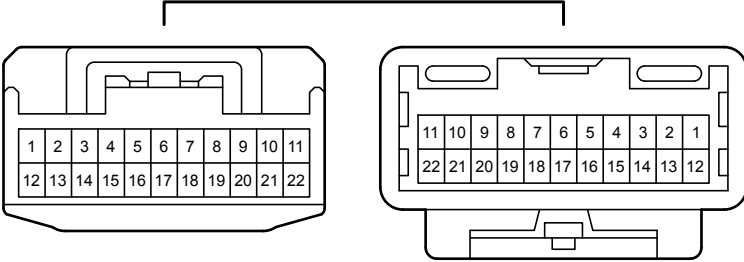

JW1  
White

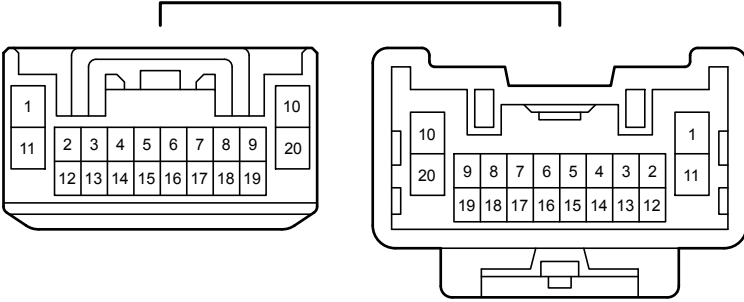

MJ1  
Blue

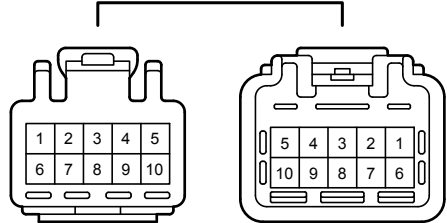

MJ3  
Blue

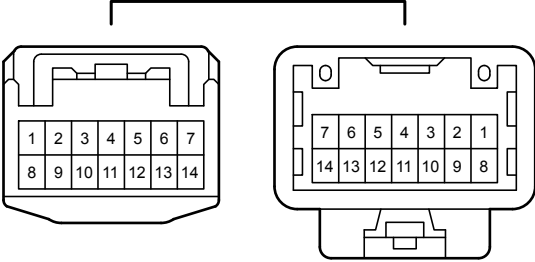

NJ1  
Blue

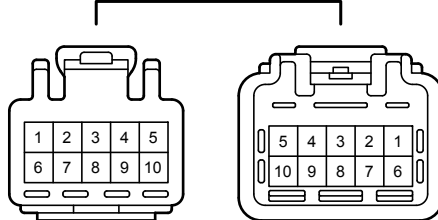

Theft Deterrent

NJ2  
Blue

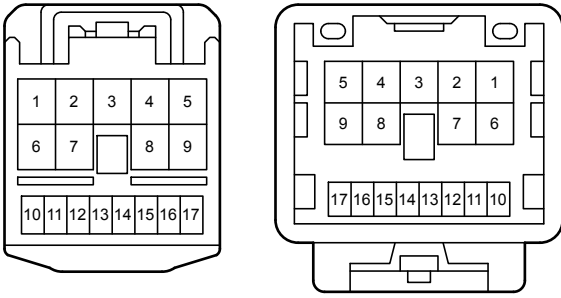

OP1  
White

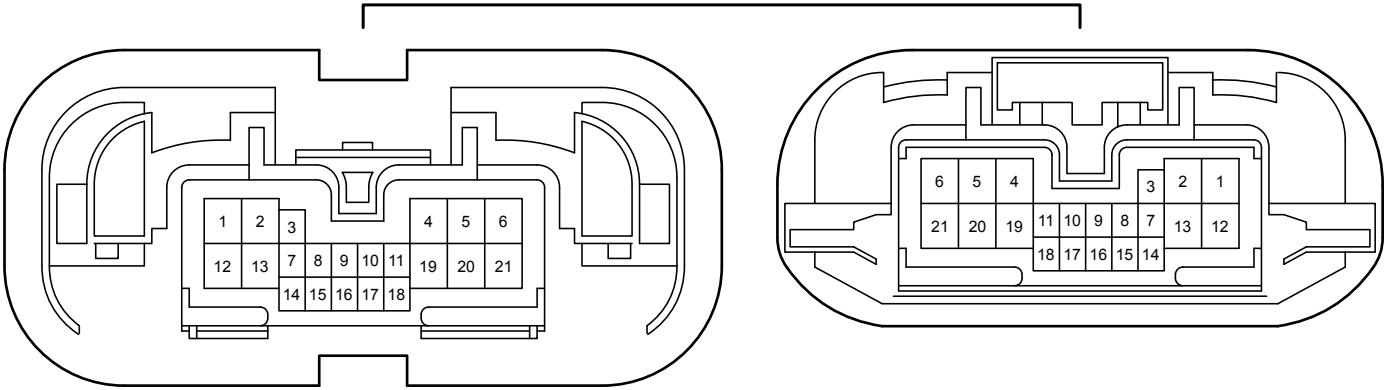

OQ1  
White

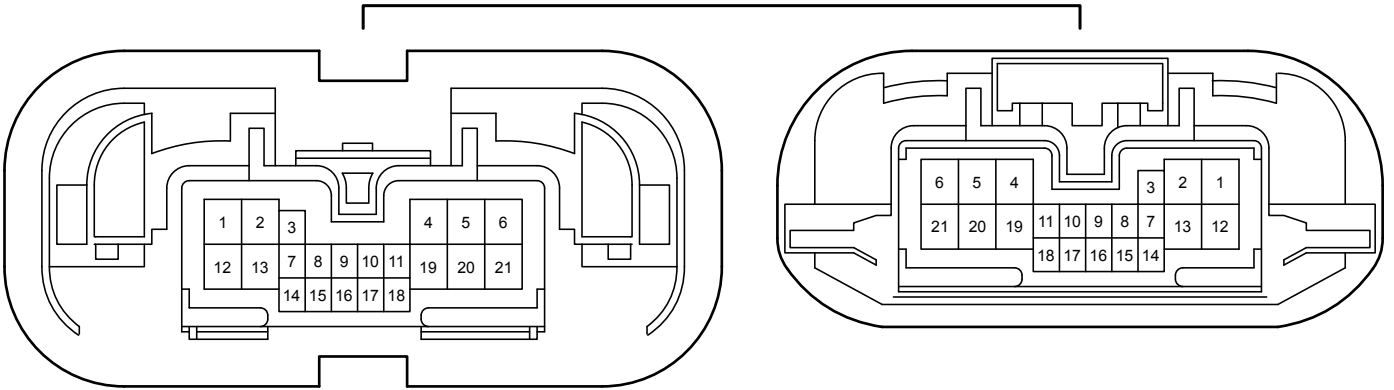

PJ1  
Black

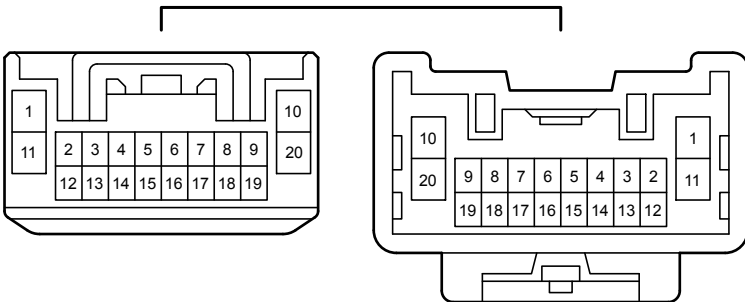

# Taillight

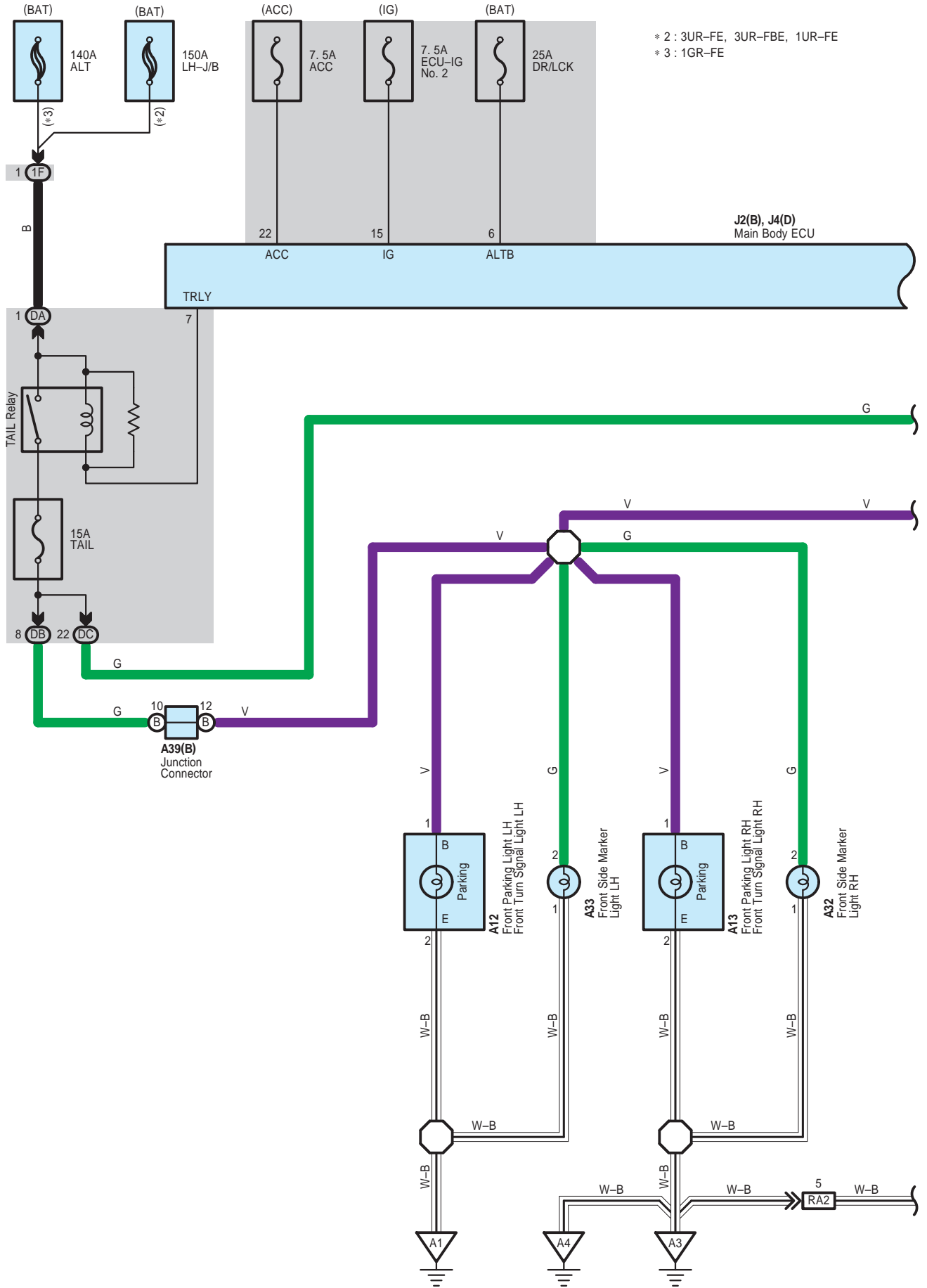

\* 2 : 3UR-FE, 3UR-FBE, 1UR-FE  
 \* 3 : 1GR-FE

# Taillight

J2(B), J4(D)  
Main Body ECU

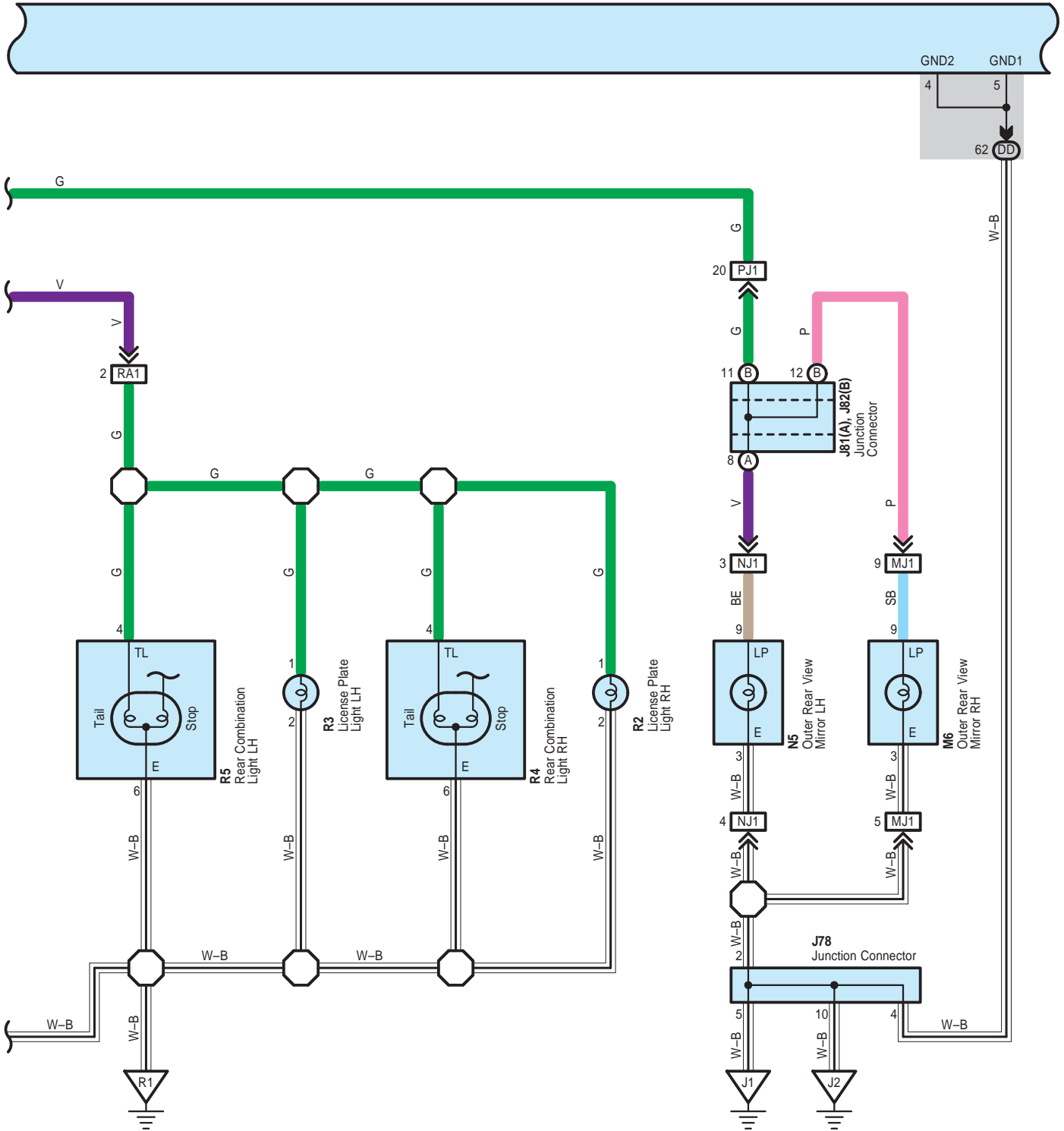

# Taillight

\* 1 : w/ Seat Position Memory

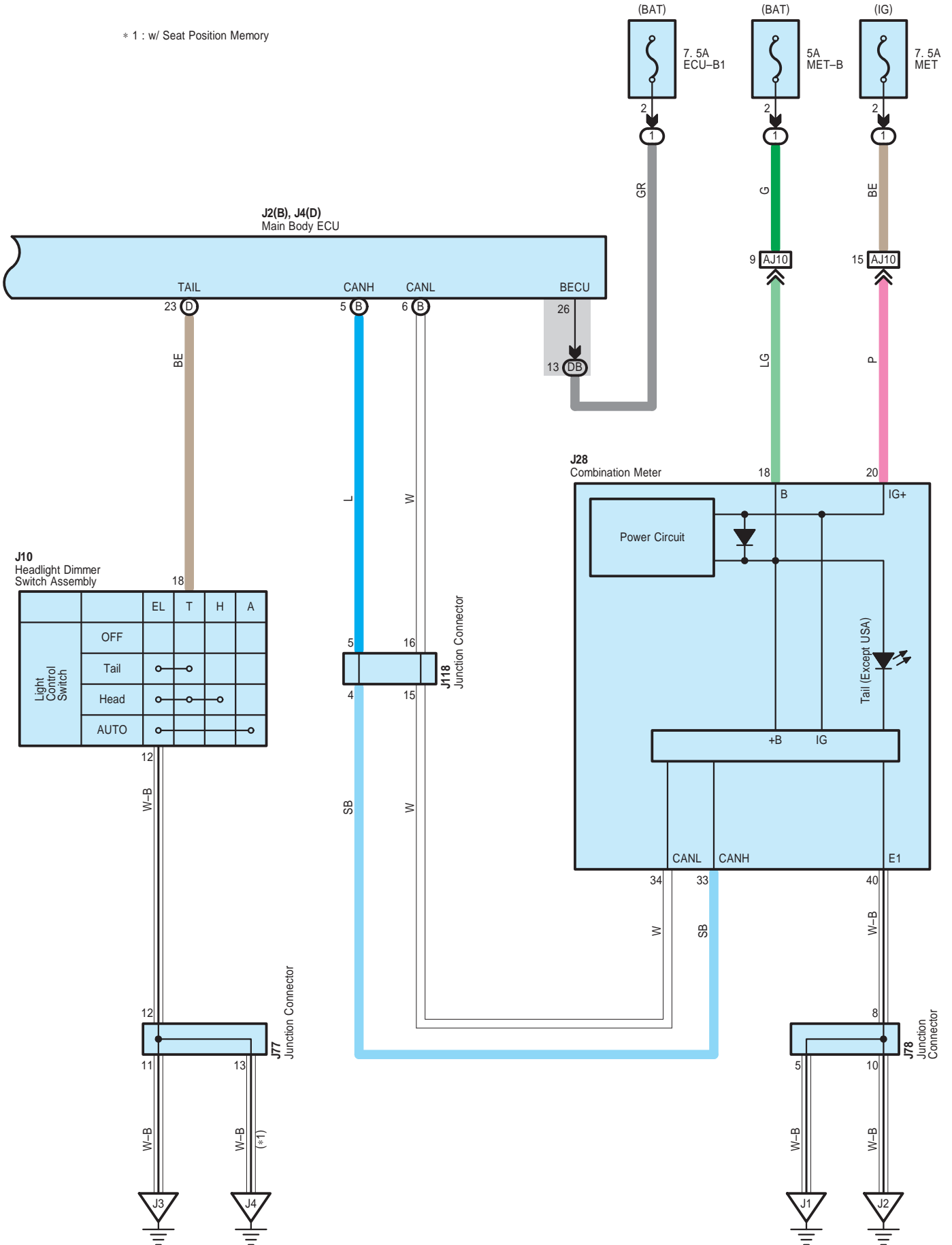



Taillight

A 12

Gray



A 13

Gray



A 32

Gray

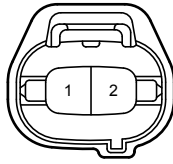

A 33

Gray

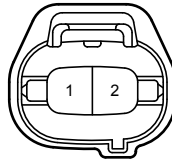

A 39

White

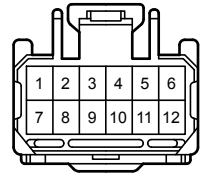

J 2

White

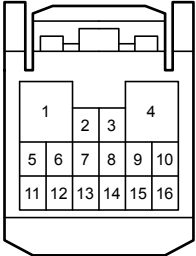

J 4

White

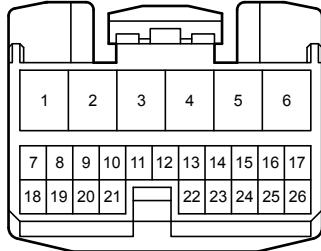

J 10

White

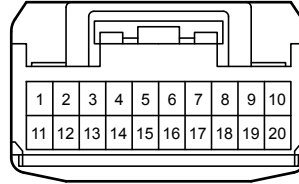

J 28

White

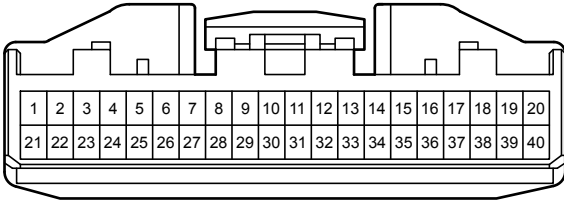

J 77

Gray

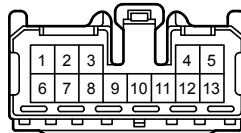

J 78

White

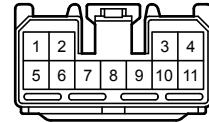

J 81

White

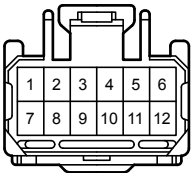

J 82

White

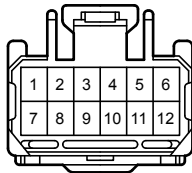

J118

Gray

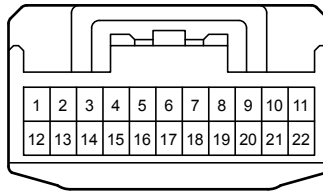

M 6

White

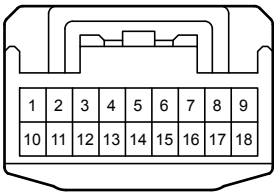

N 5

White

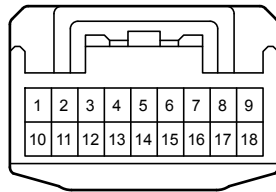

R 2

White



R 3

White



R 4

Gray



R 5

Gray



1F

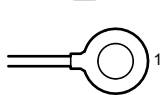

DA

White

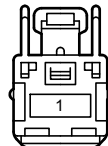

Taillight

DB  
White

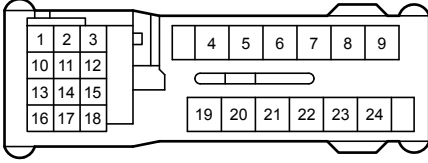

DC  
White

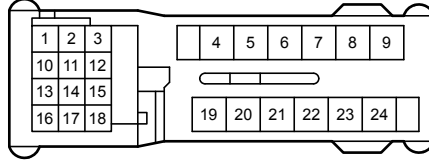

DD  
White

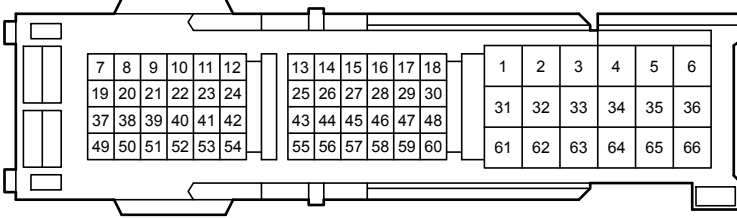

AJ10  
Gray

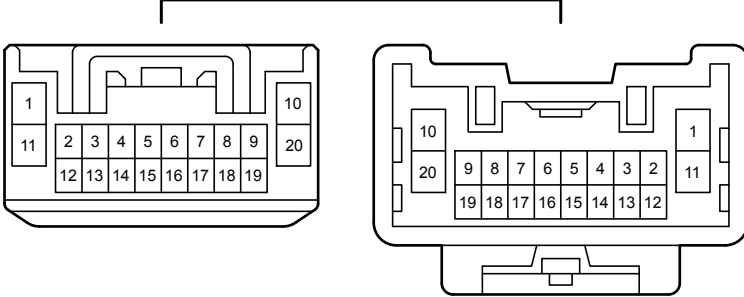

MJ1  
Blue

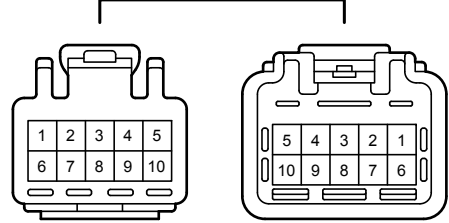

NJ1  
Blue

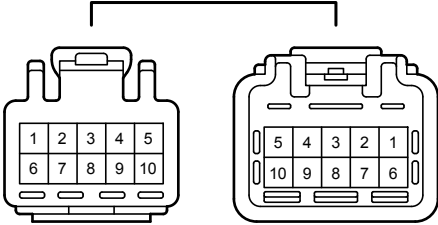

PJ1  
Black

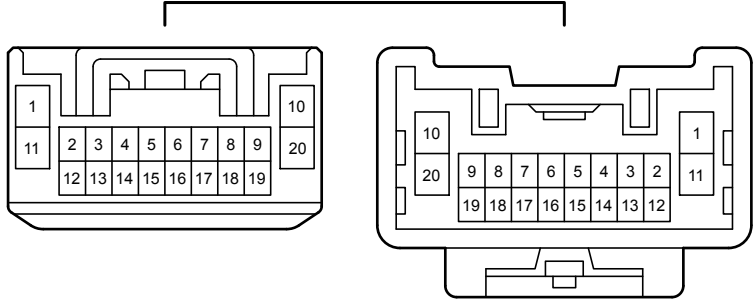

RA1  
White

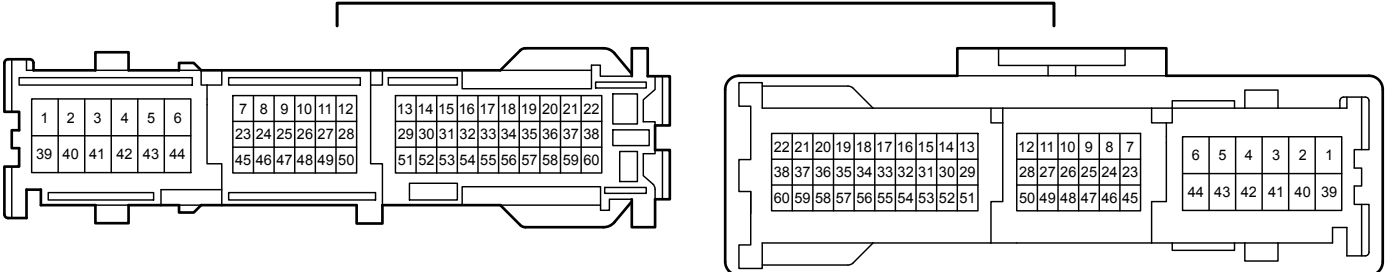

RA2  
White

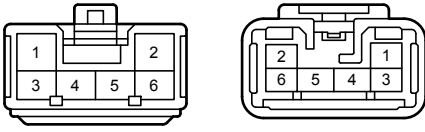

# Tire Pressure Warning System

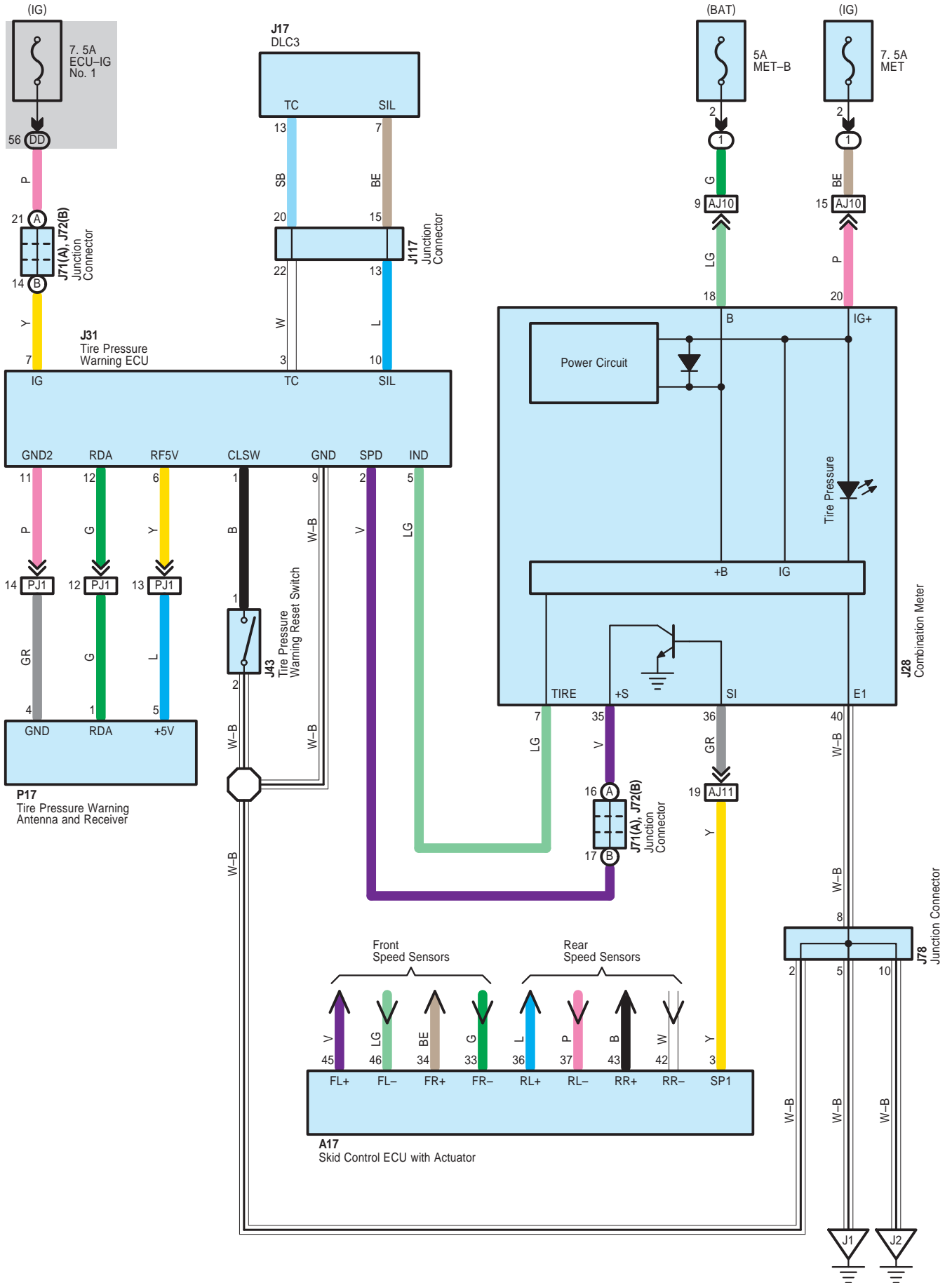

Tire Pressure Warning System

A 17  
Black

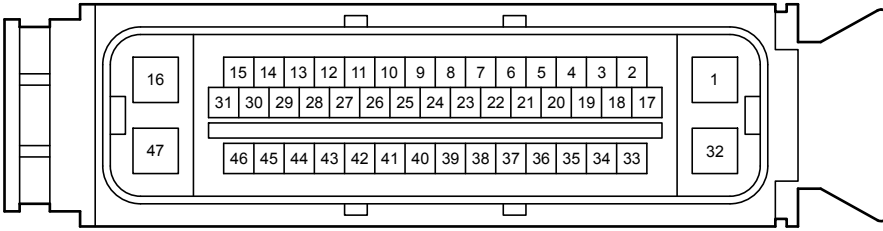

J 17  
White

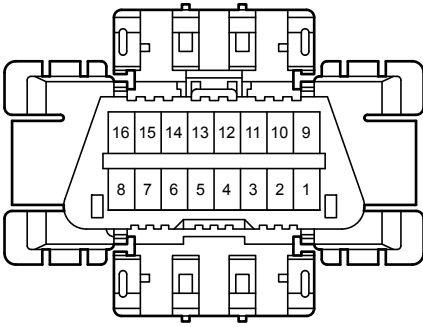

J 28  
White

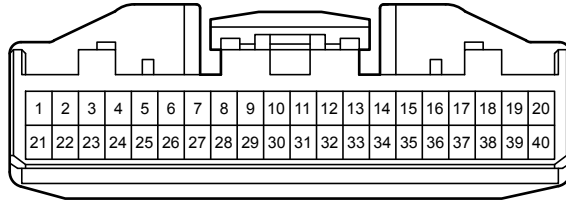

J 31  
White

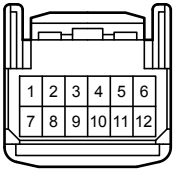

J 43  
Black

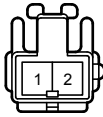

J 71  
Black

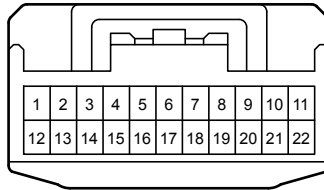

J 72  
Black

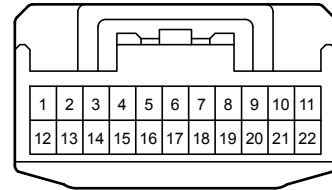

J 78  
White

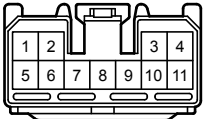

J117  
Black

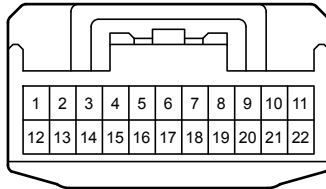

P 17  
White

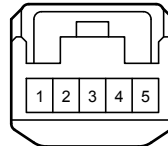

DD  
White

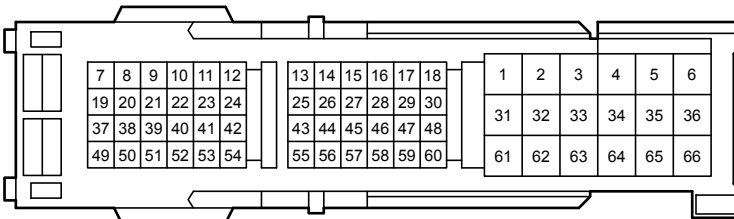

Tire Pressure Warning System

AJ10  
Gray

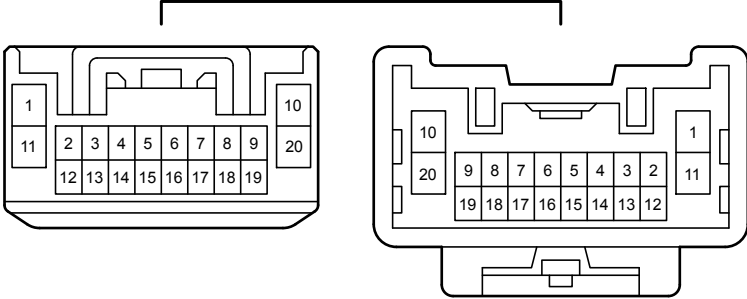

AJ11  
Gray

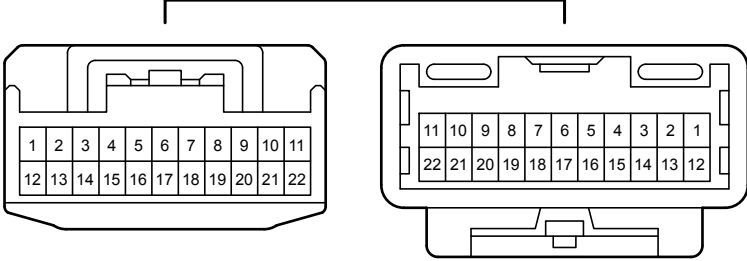

PJ1  
Black

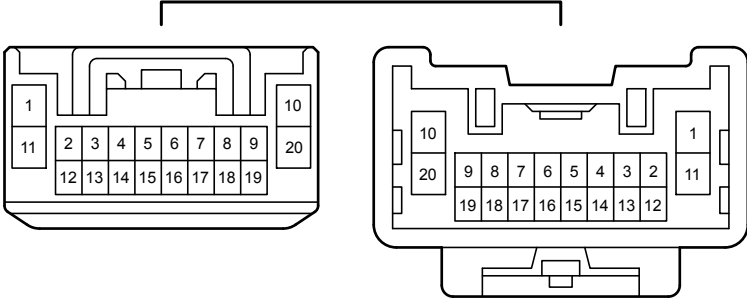

# Turn Signal and Hazard Warning Light

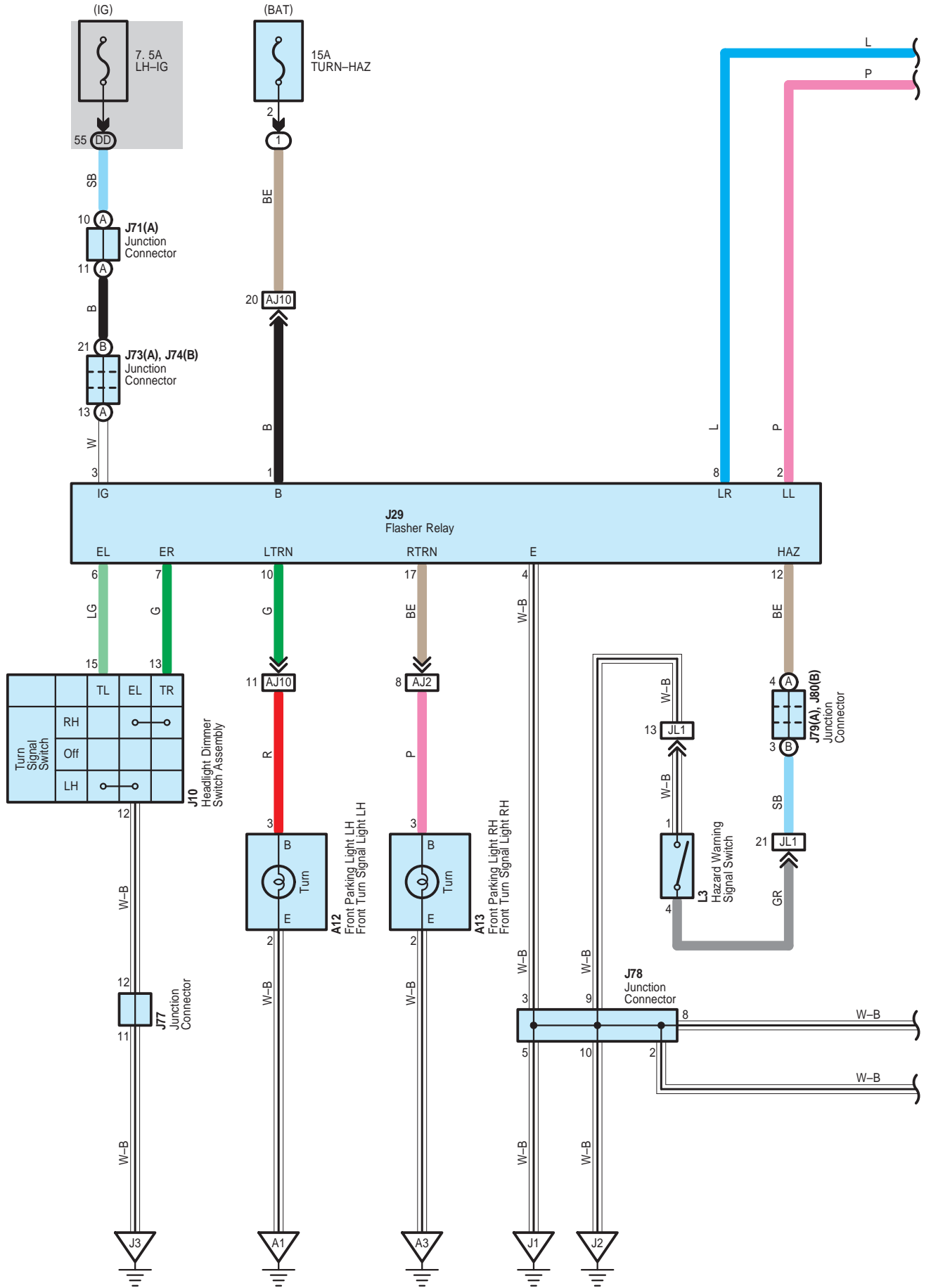

# Turn Signal and Hazard Warning Light

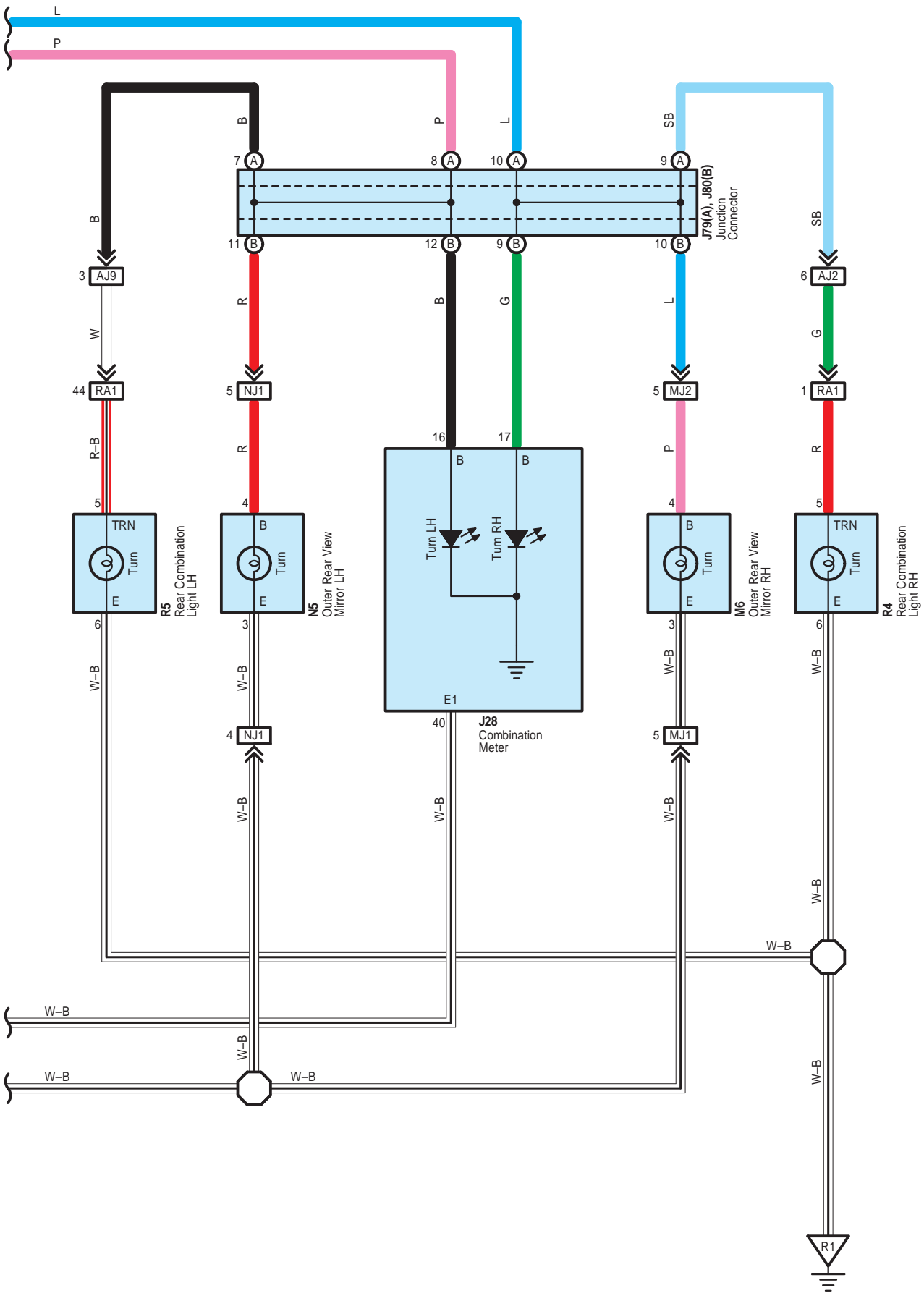



Turn Signal and Hazard Warning Light

A 12

Gray



A 13

Gray



J 10

White

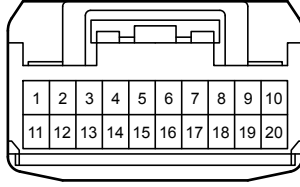

J 28

White

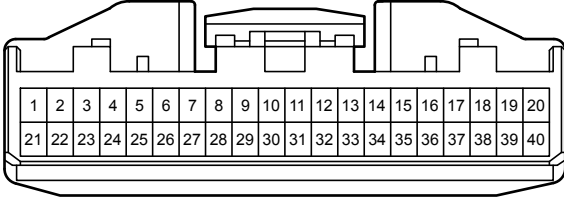

J 29

White

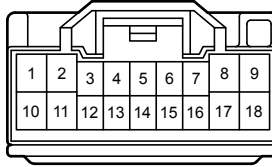

J 71

Black

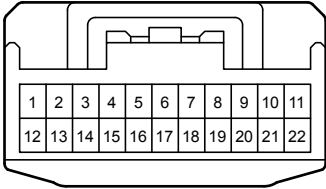

J 73

Black

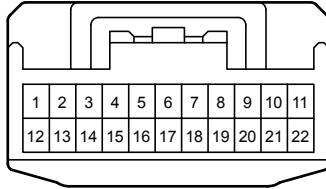

J 74

Black

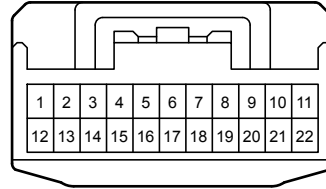

J 77

Gray

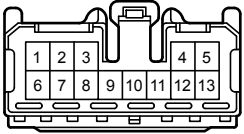

J 78

White

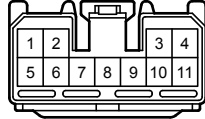

J 79

White

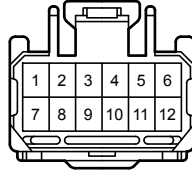

J 80

White

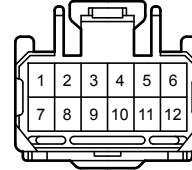

L 3

Gray

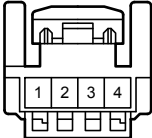

M 6

White

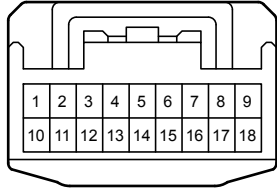

N 5

White

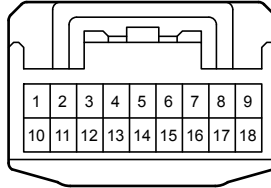

R 4

Gray

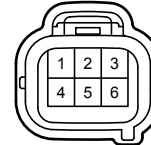

R 5

Gray



DD

White

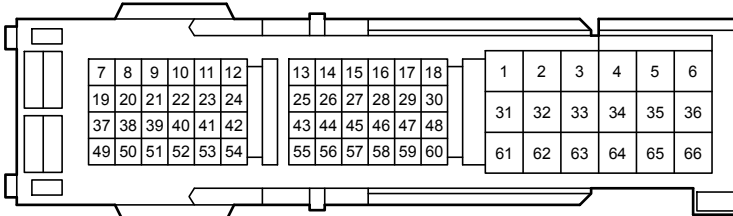

Turn Signal and Hazard Warning Light

AJ2

White

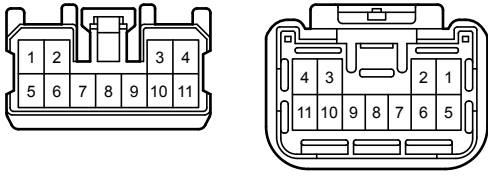

AJ9

Gray

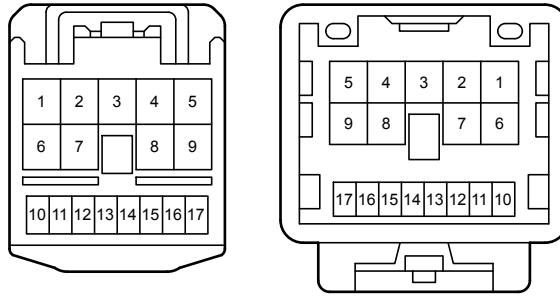

AJ10

Gray

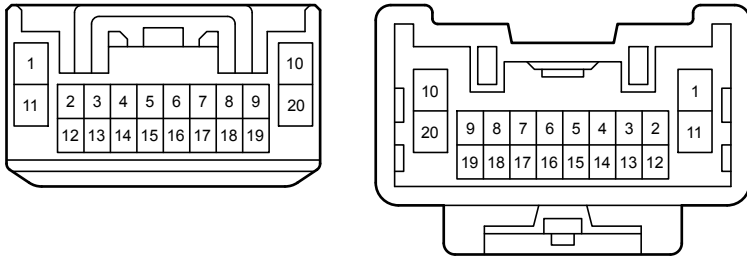

JL1

White

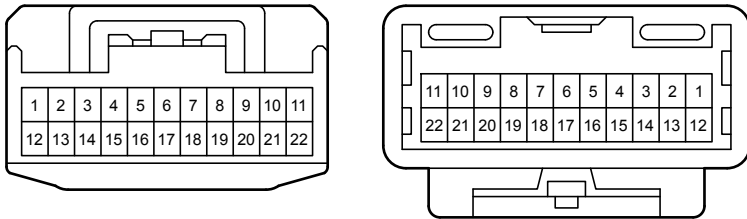

MJ1

Blue

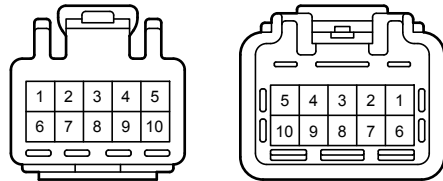

MJ2

Blue

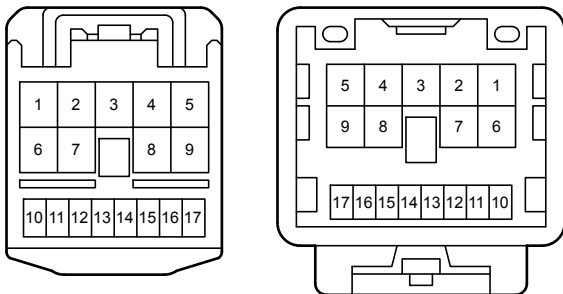

NJ1

Blue

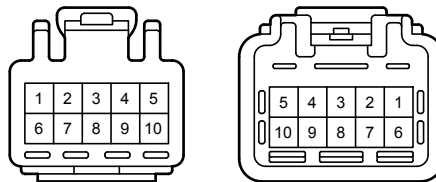

# Turn Signal and Hazard Warning Light

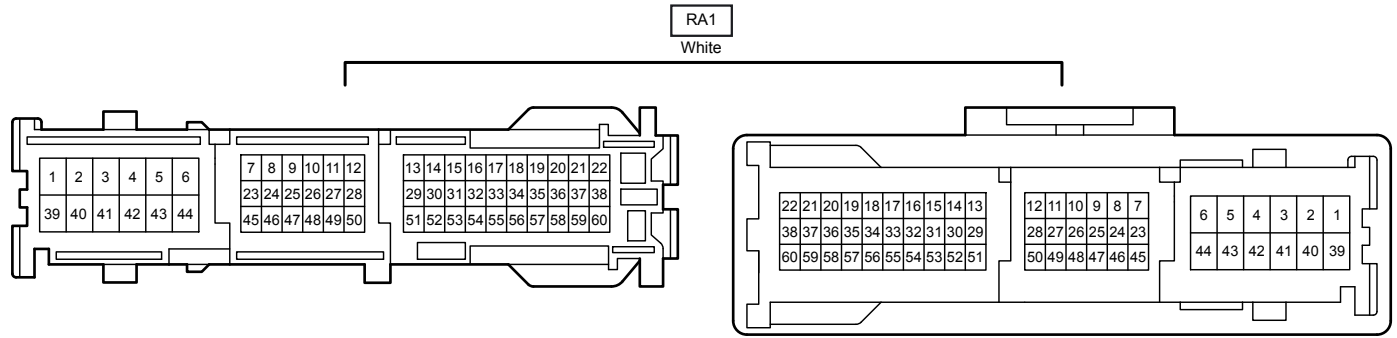

# Trailer Towing

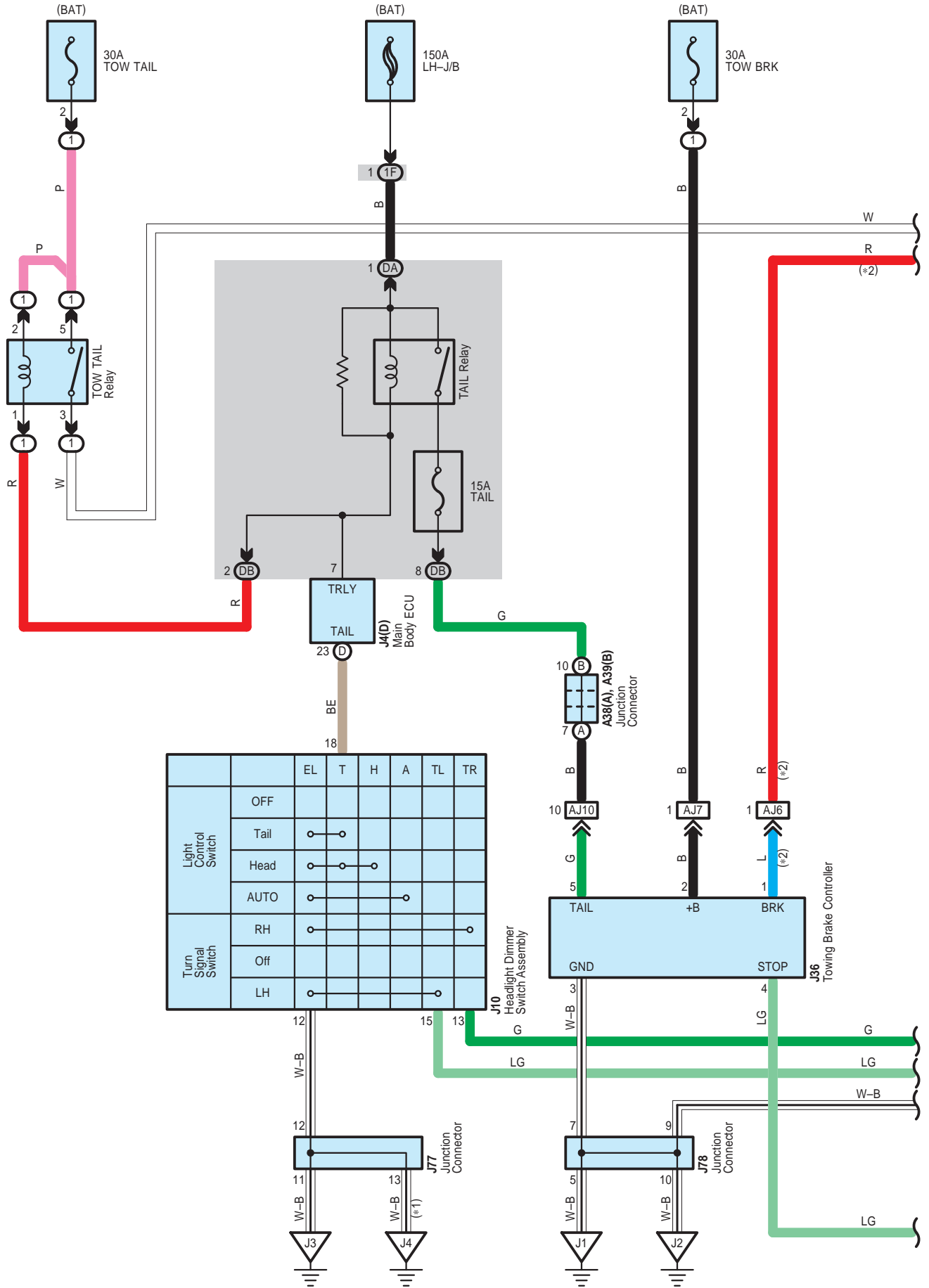

# Trailer Towing

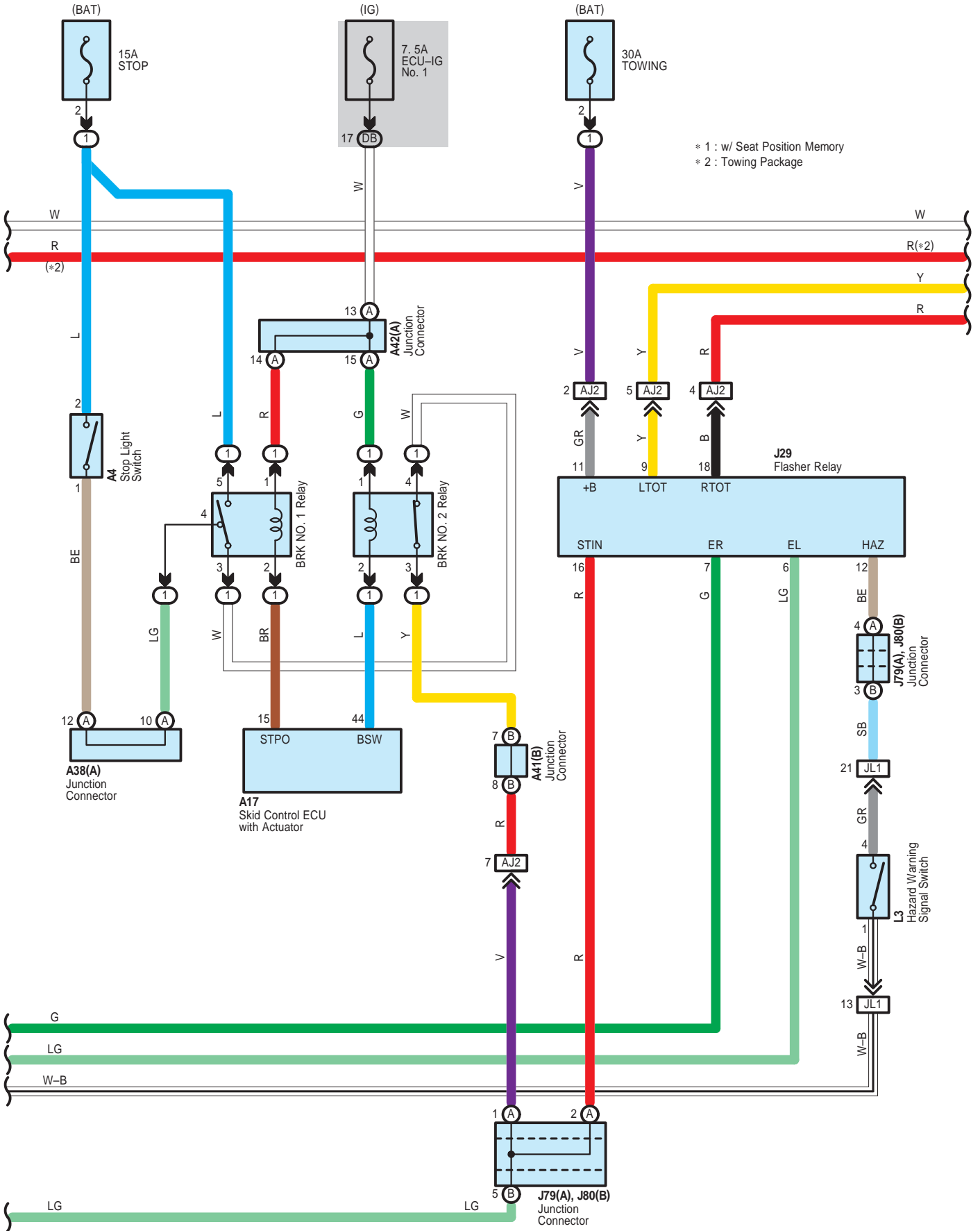

# Trailer Towing

- \* 2 : Towing Package
- \* 3 : Except Towing Package
- \* 4 : Column Shift
- \* 5 : Floor Shift

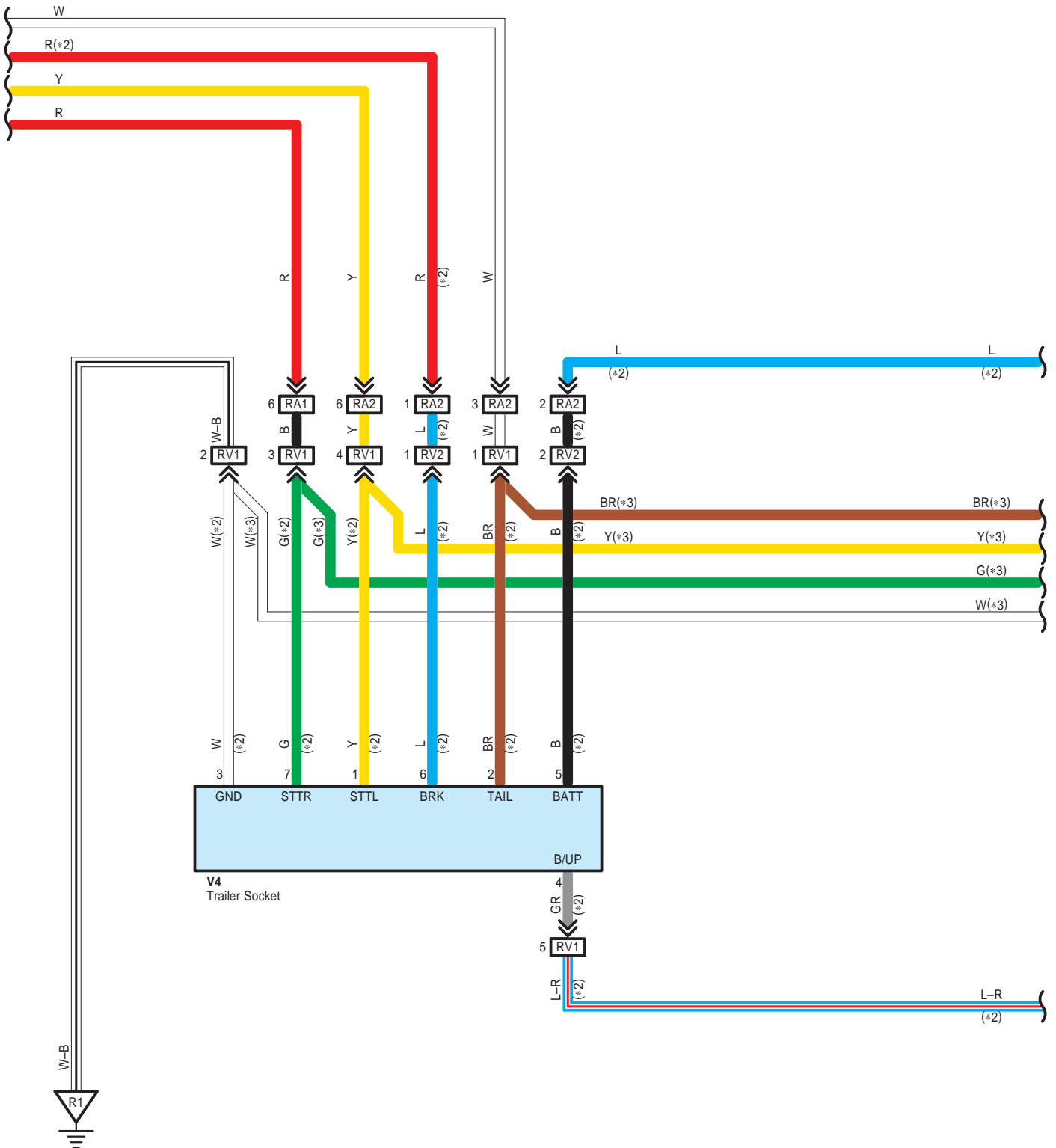

# Trailer Towing

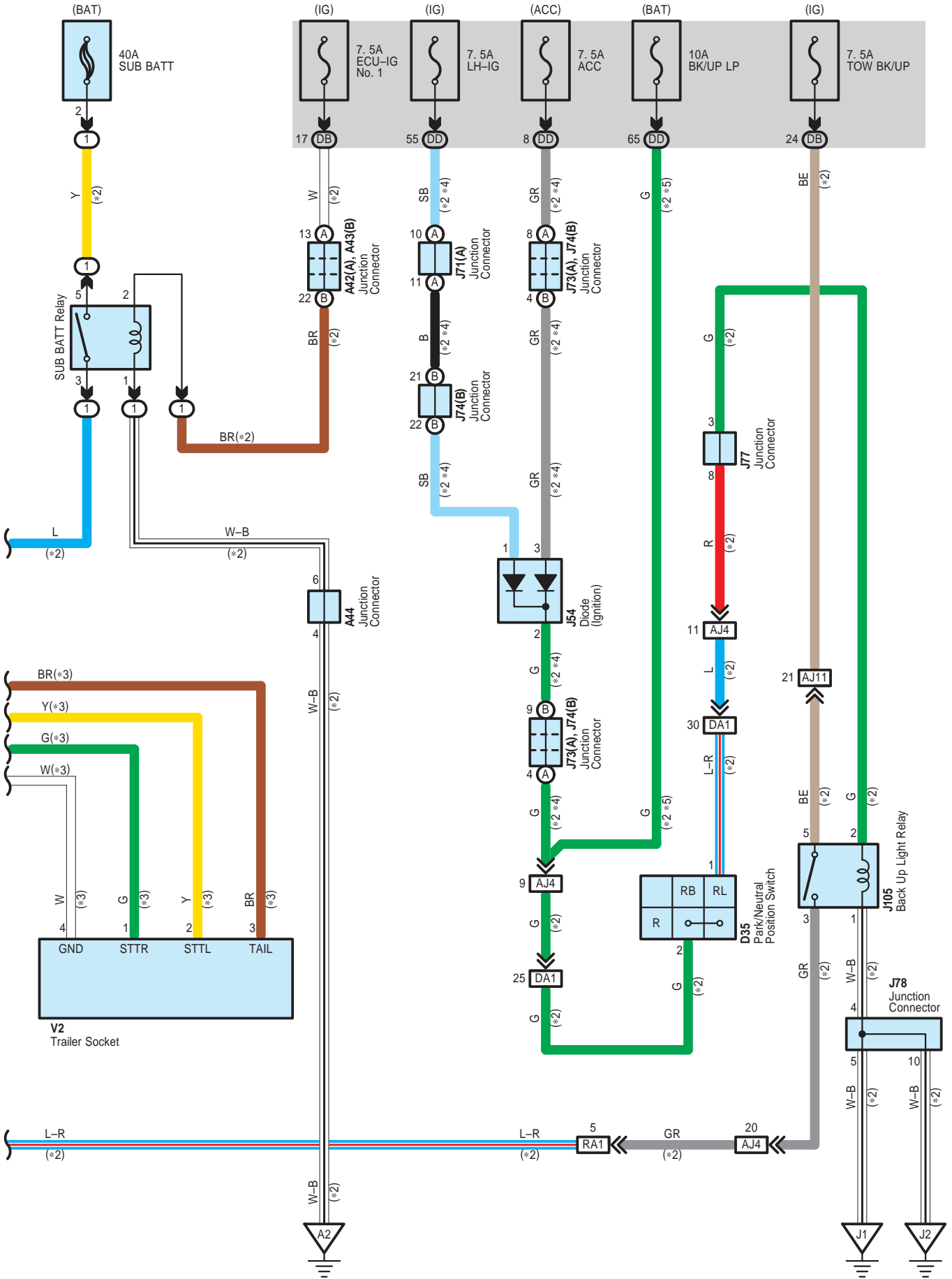

# Trailer Towing

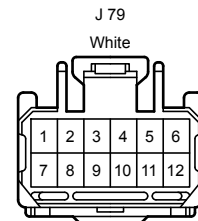
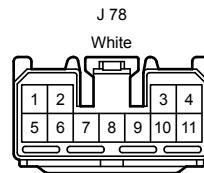
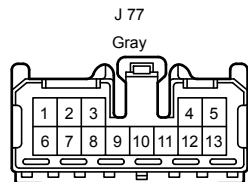
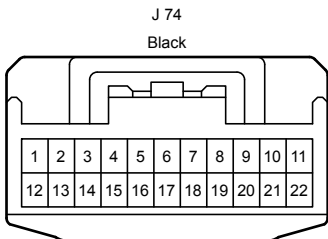
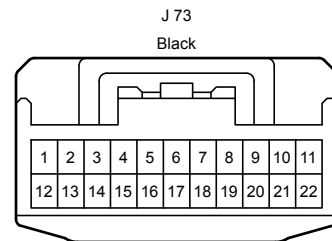
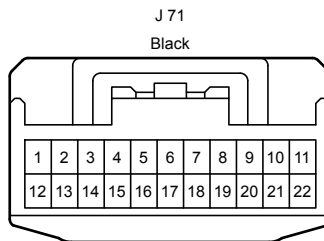
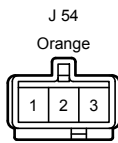
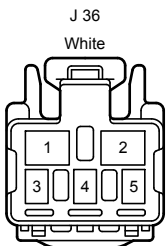
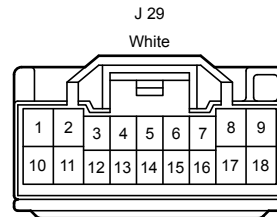
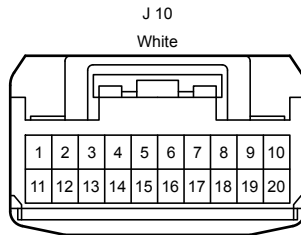
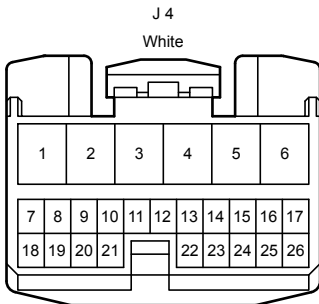
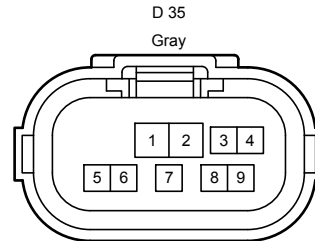
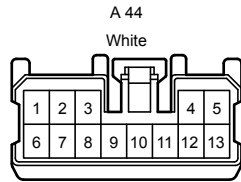
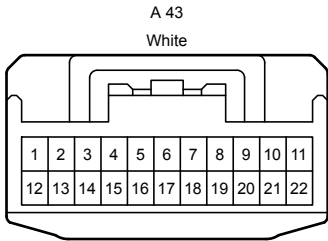
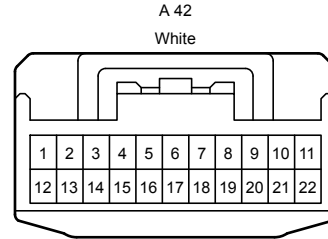
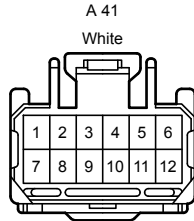
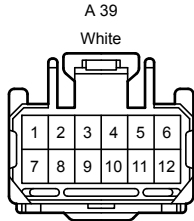
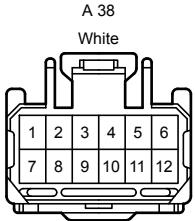
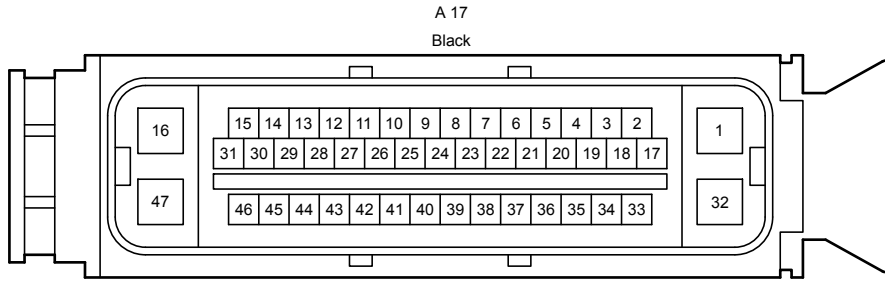
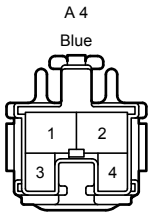



Trailer Towing

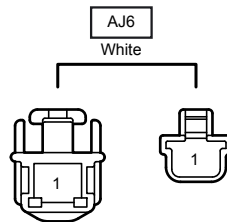
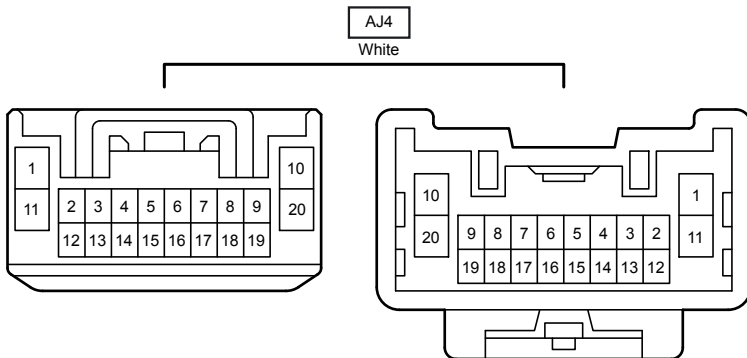
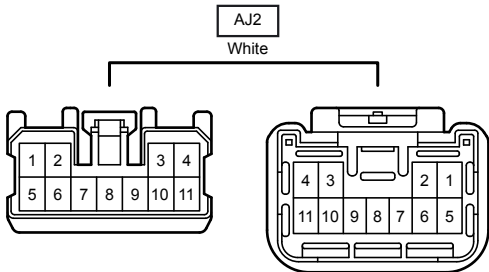
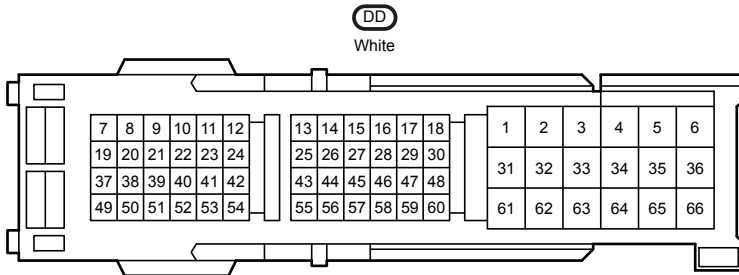
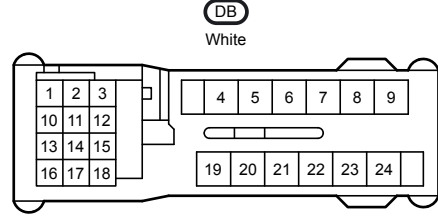
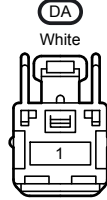
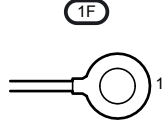
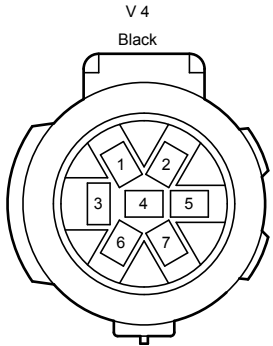
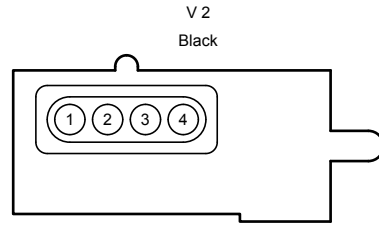
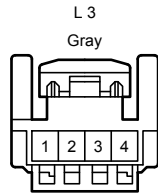
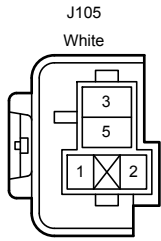
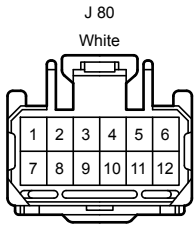

# Trailer Towing

AJ7  
Gray

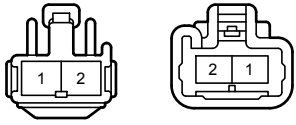

AJ10  
Gray

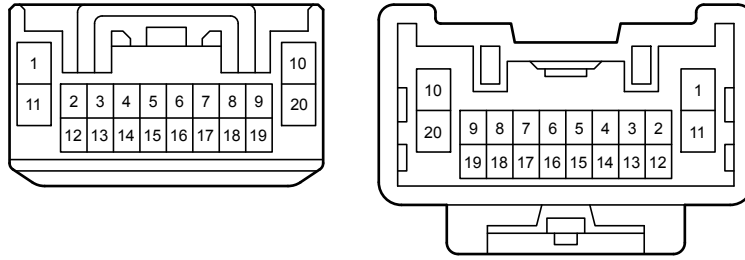

AJ11  
Gray

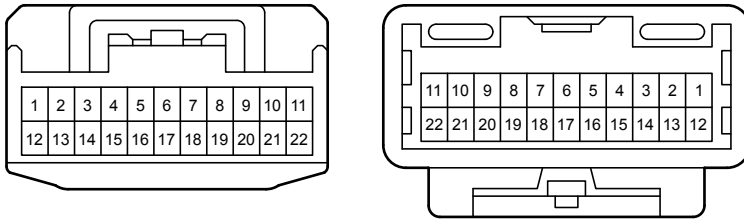

DA1  
White

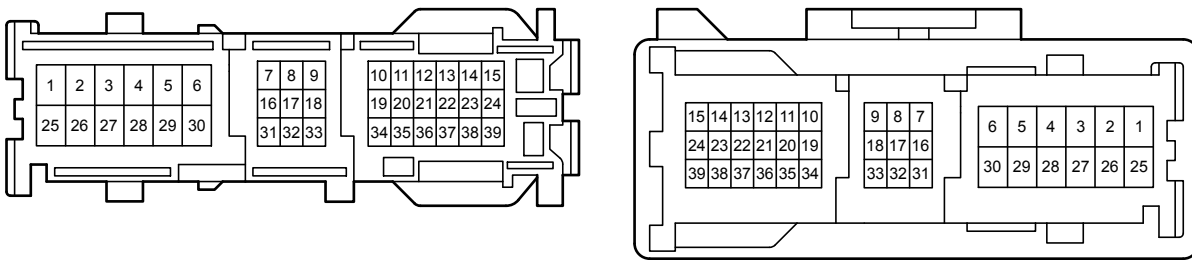

JL1  
White

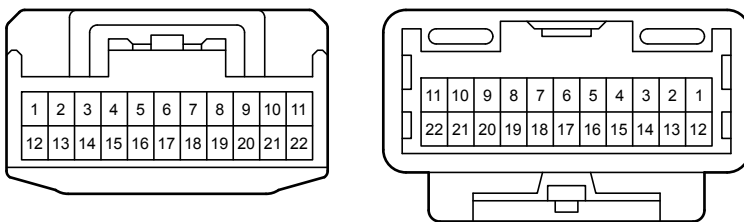

RA1  
White

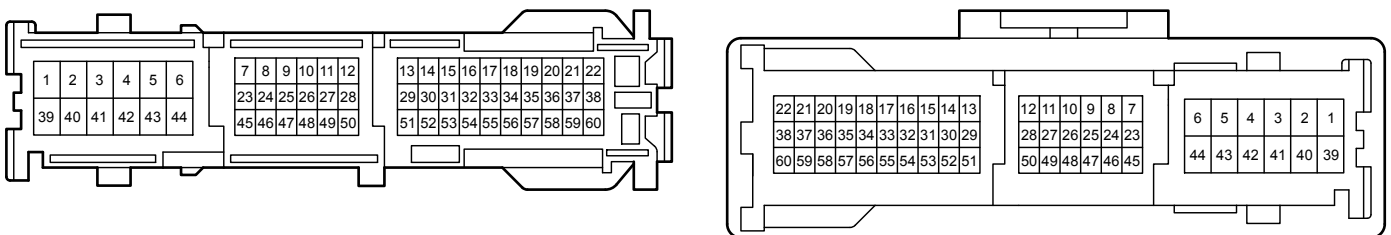

Trailer Towing

RA2

White

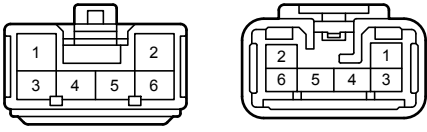

RV1

Gray

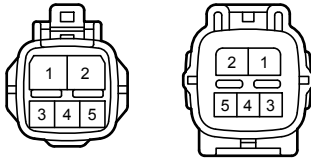

RV2

Gray



Wireless Door Lock Control

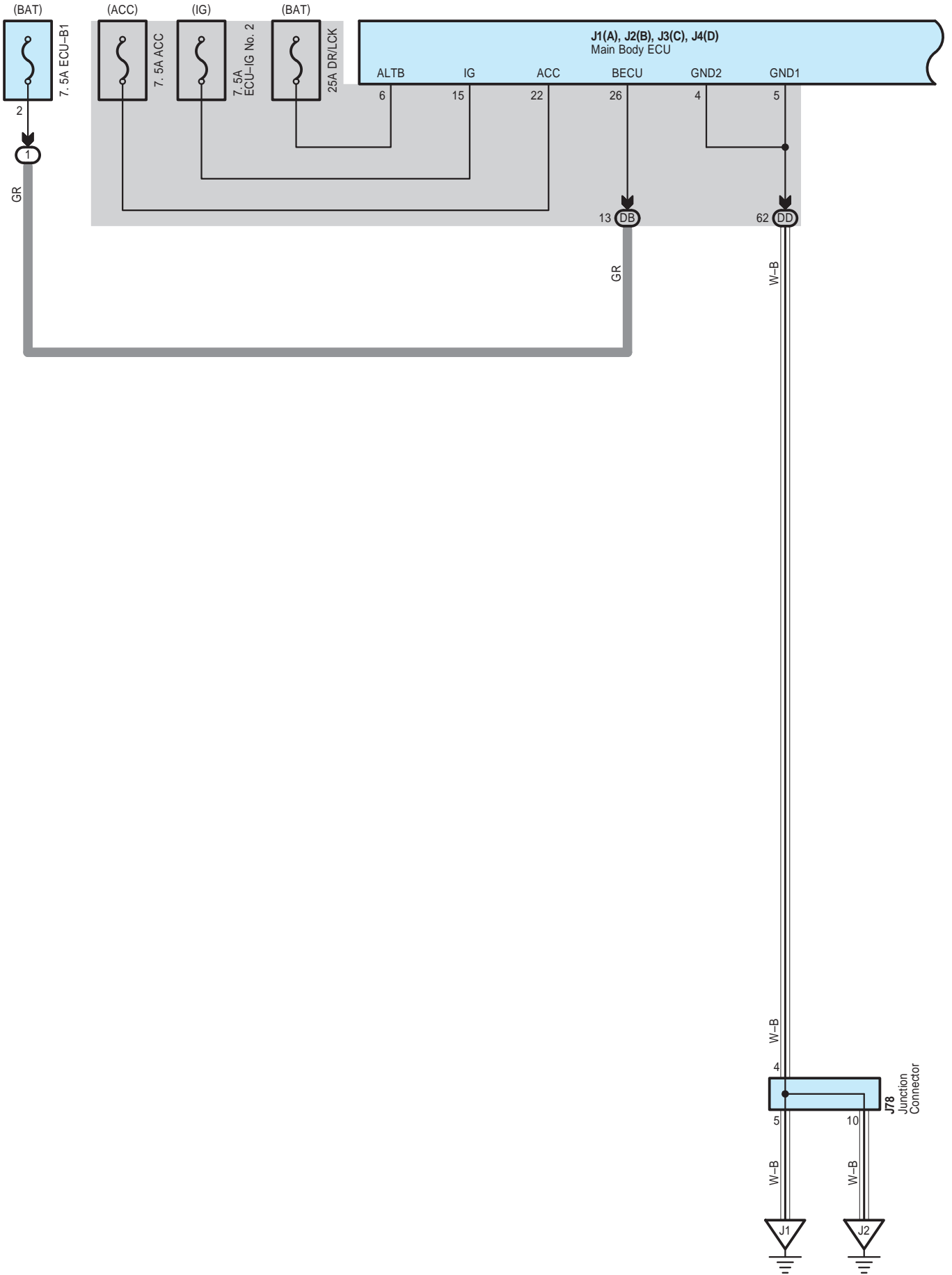

Wireless Door Lock Control

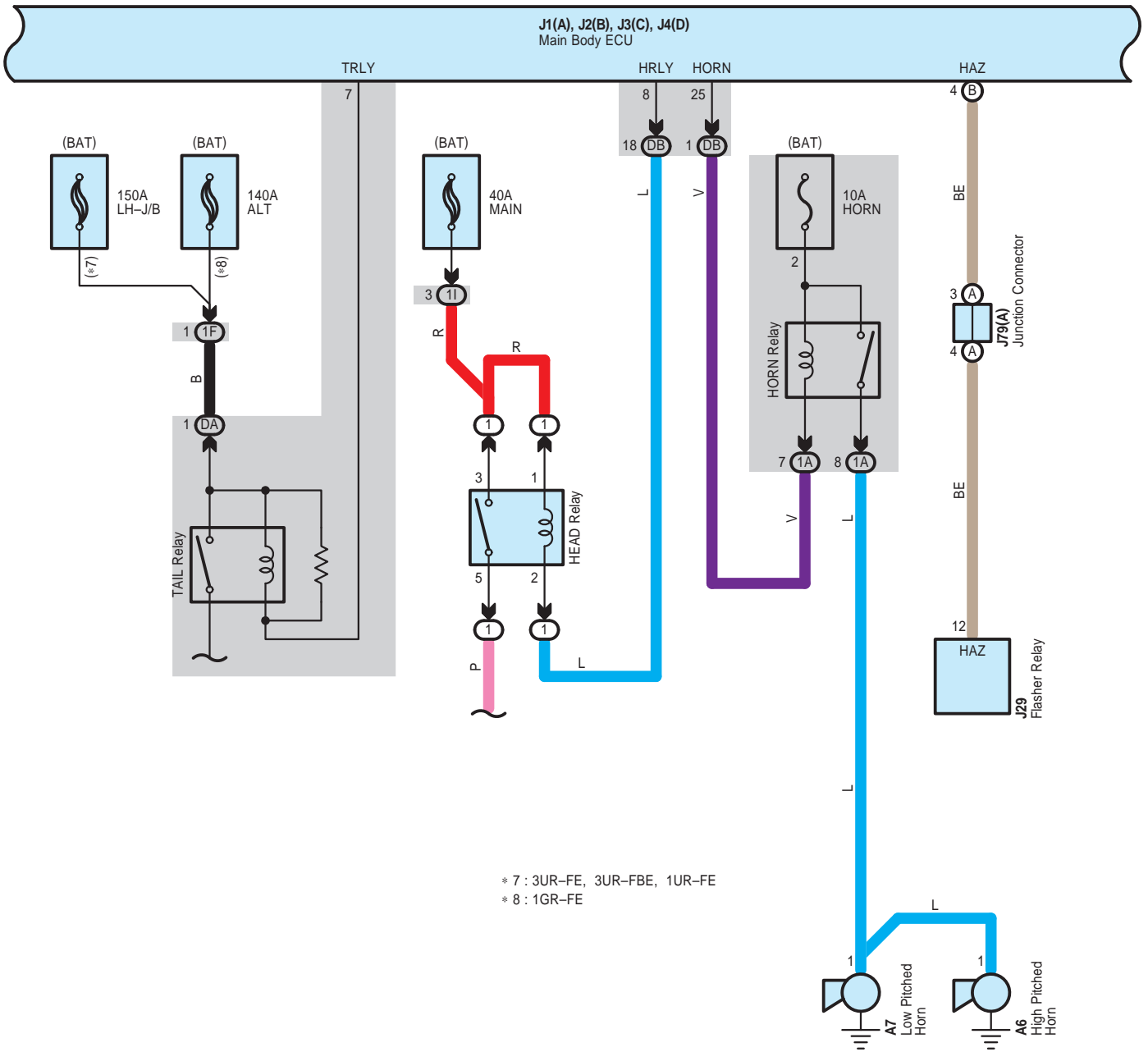

Wireless Door Lock Control

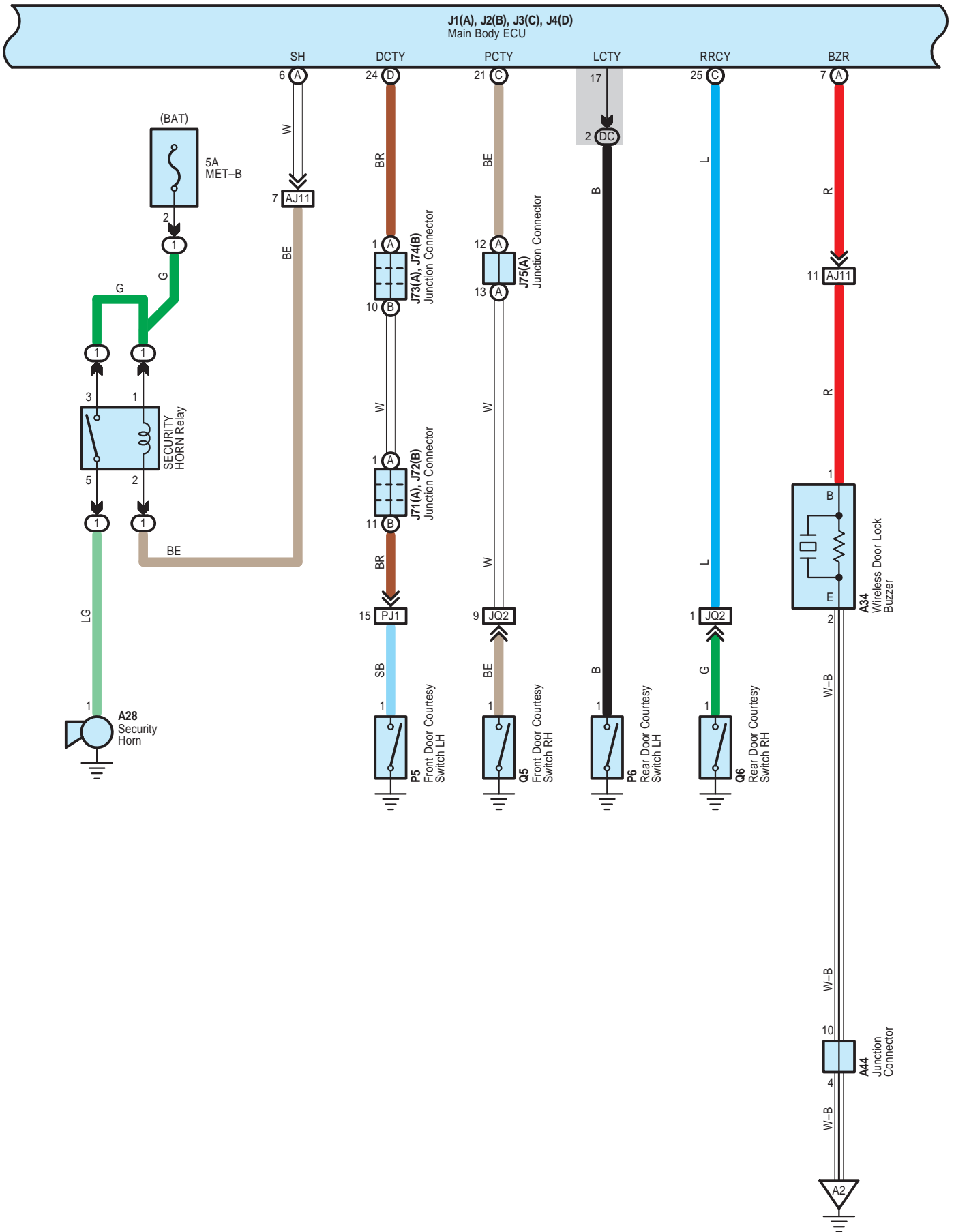



Wireless Door Lock Control

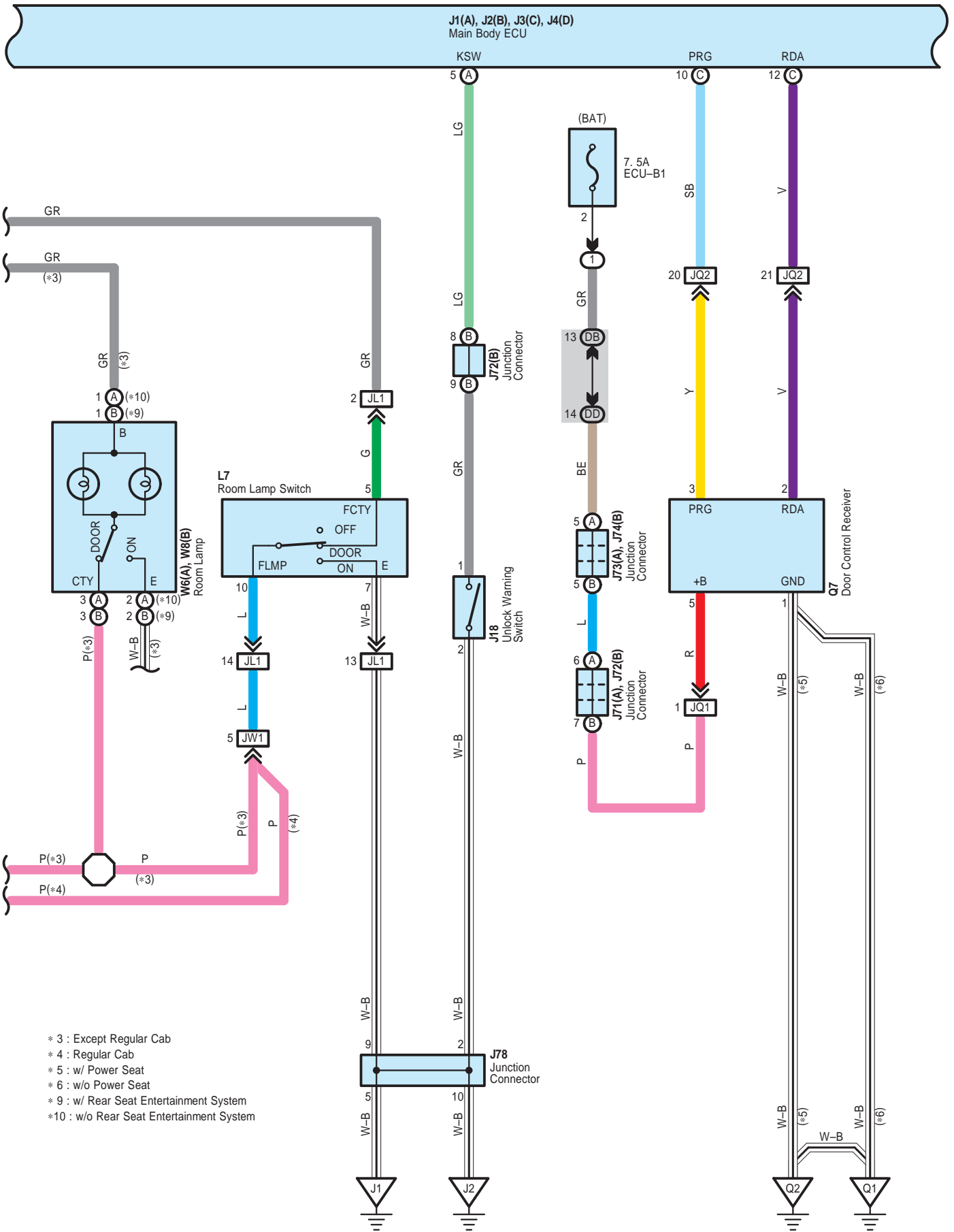

- \* 3 : Except Regular Cab
- \* 4 : Regular Cab
- \* 5 : w/ Power Seat
- \* 6 : w/o Power Seat
- \* 9 : w/ Rear Seat Entertainment System
- \* 10 : w/o Rear Seat Entertainment System



Wireless Door Lock Control

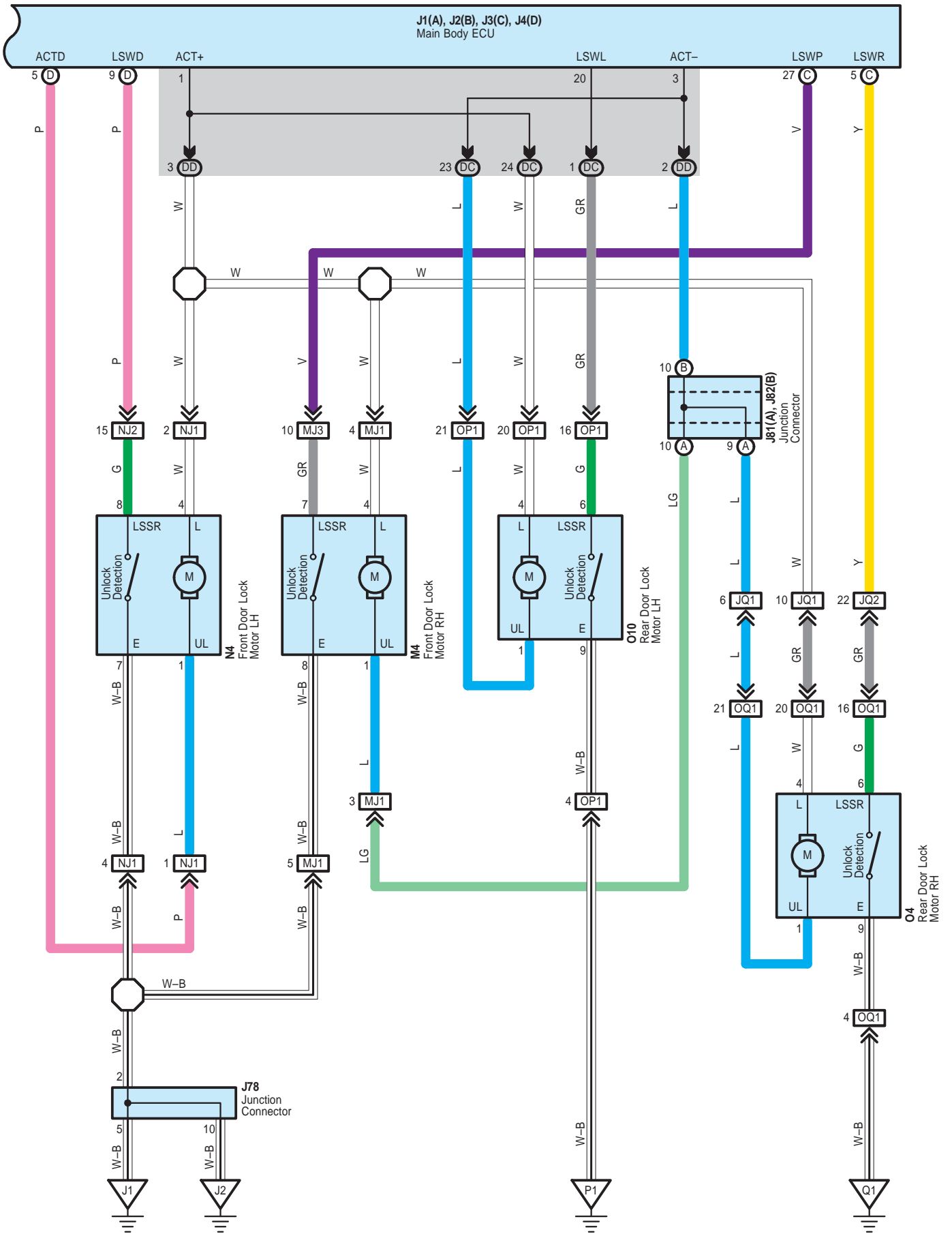

Wireless Door Lock Control

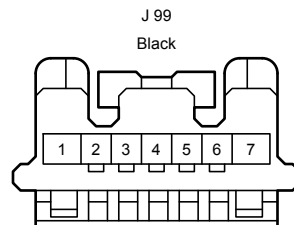
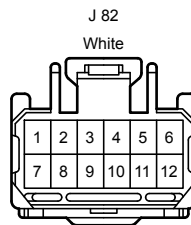
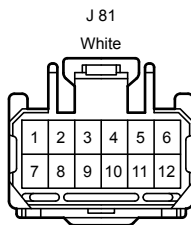
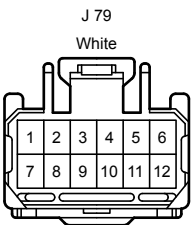
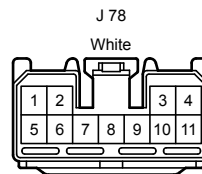
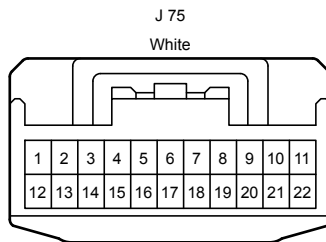
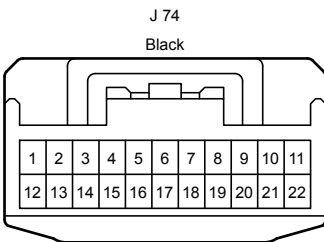
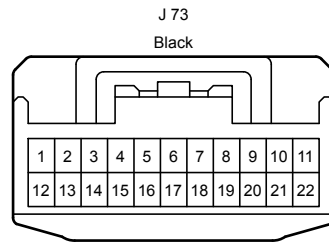
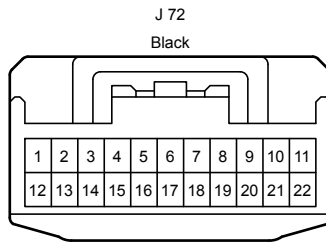
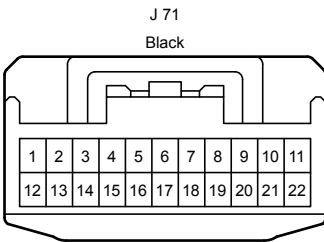
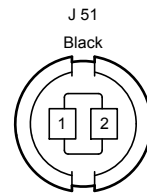
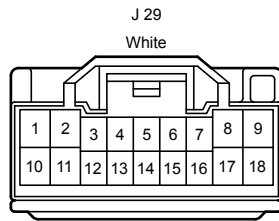
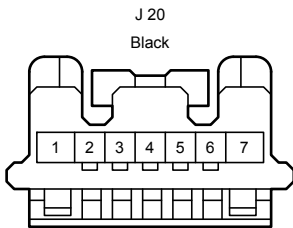
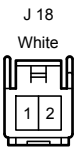
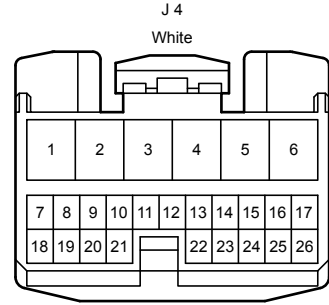
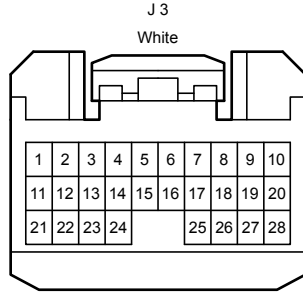
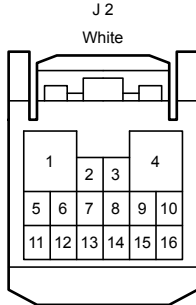
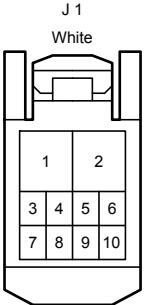
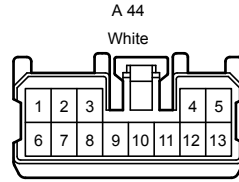
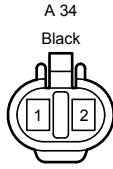

Wireless Door Lock Control

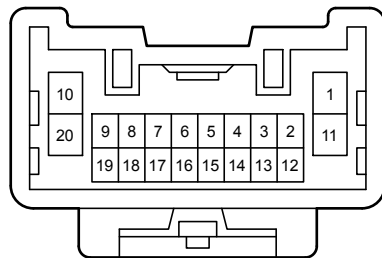
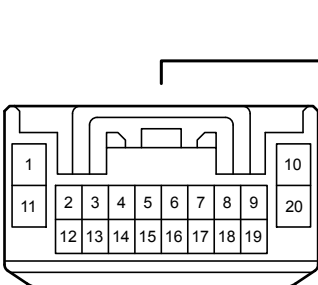
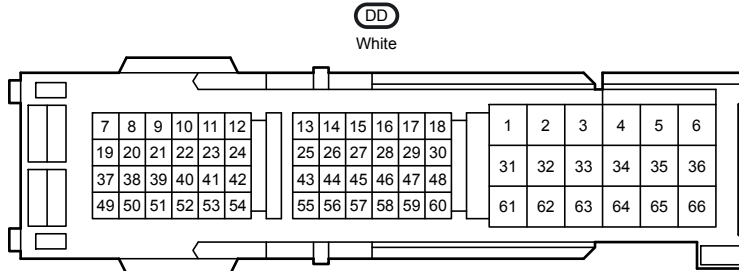
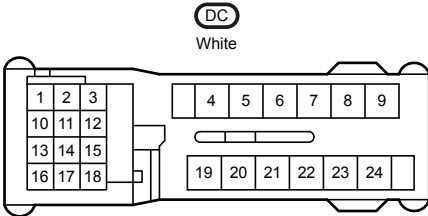
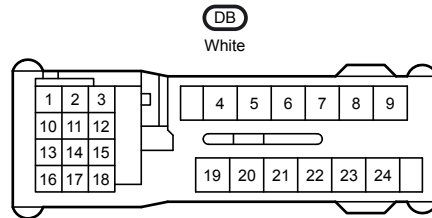
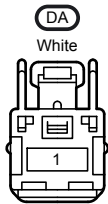
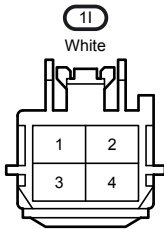
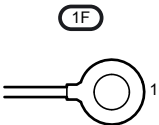
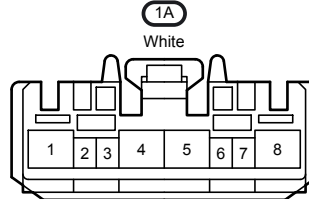
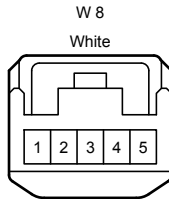
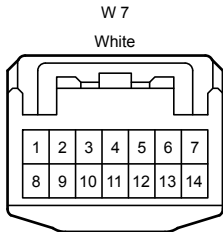
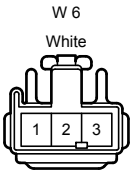
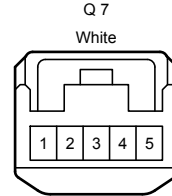
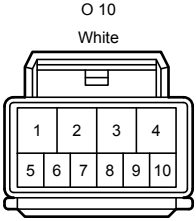
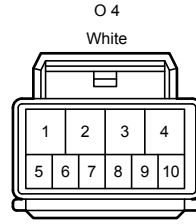
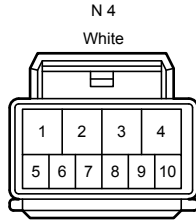
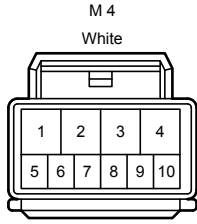
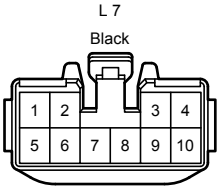

AJ11  
Gray

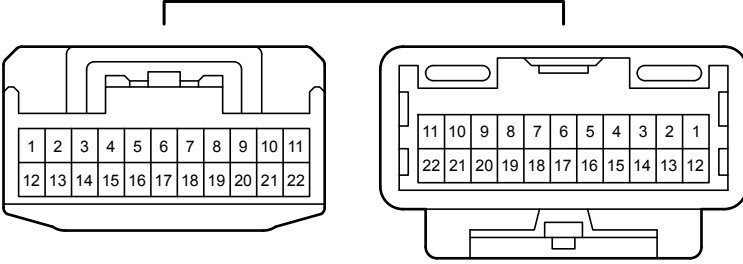

JL1  
White

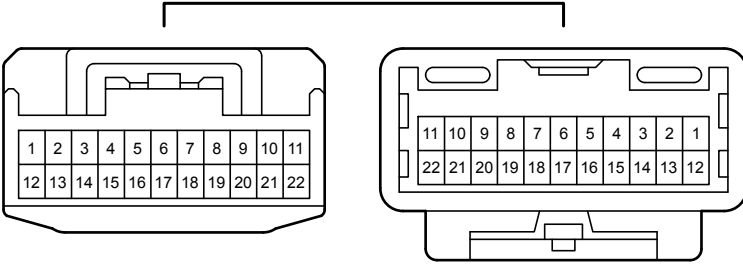

JQ1  
Gray

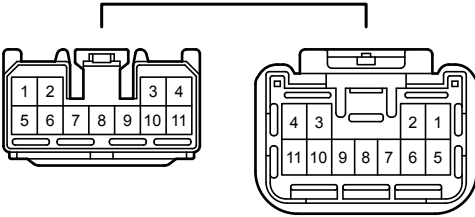

JQ2  
Gray

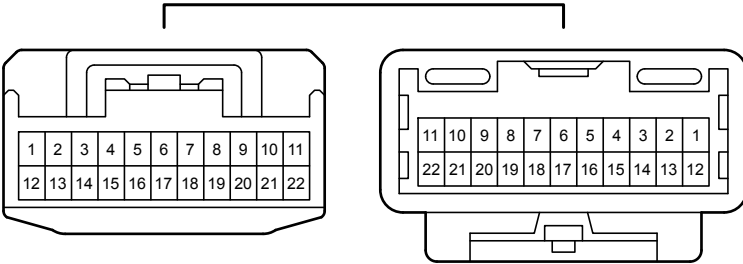

JW1  
White

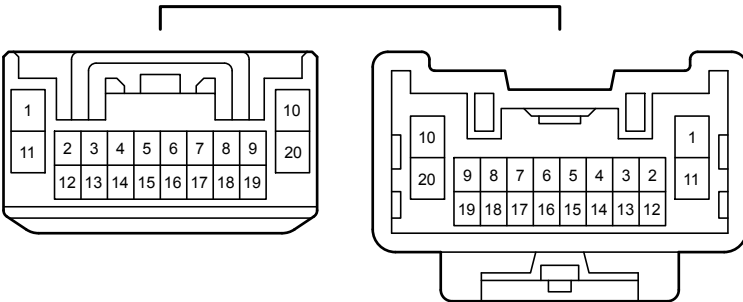

MJ1  
Blue

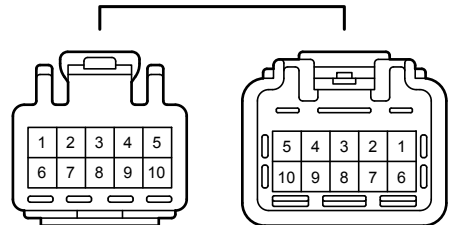

Wireless Door Lock Control

MJ3  
Blue

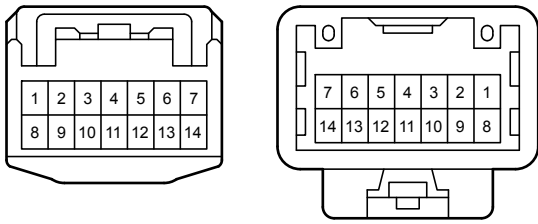

NJ1  
Blue

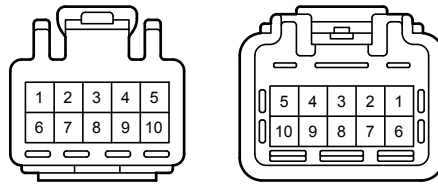

NJ2  
Blue

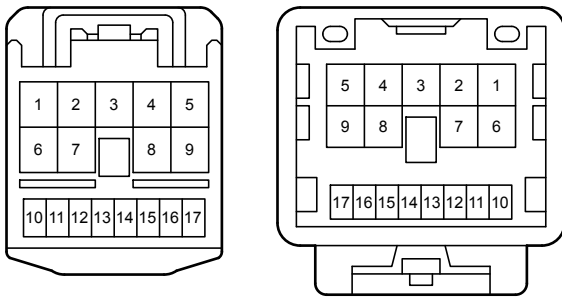

OP1  
White

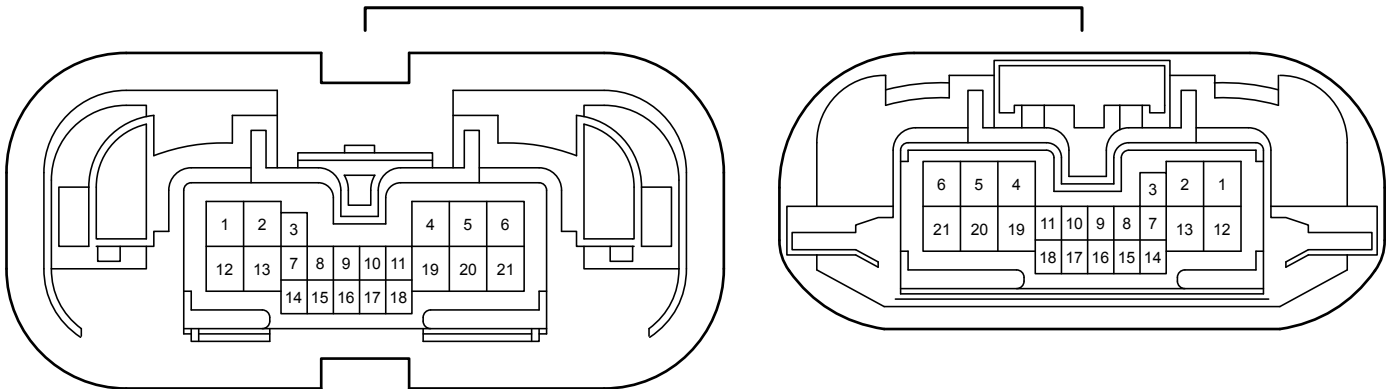

OQ1  
White

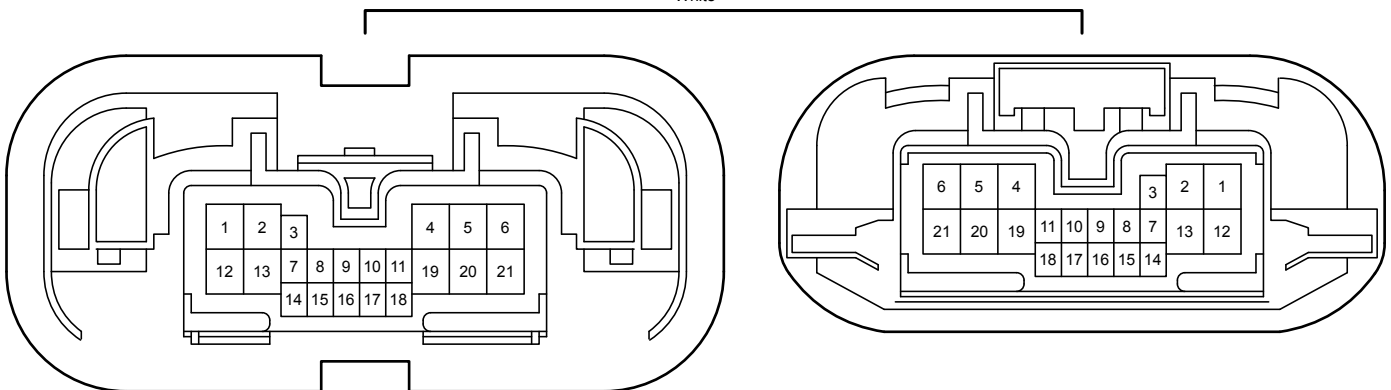

PJ1  
Black

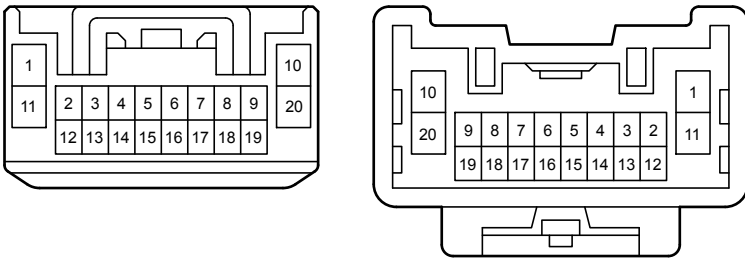

# Location & Routing

Ground Points in Engine Compartment <1GR-FE>

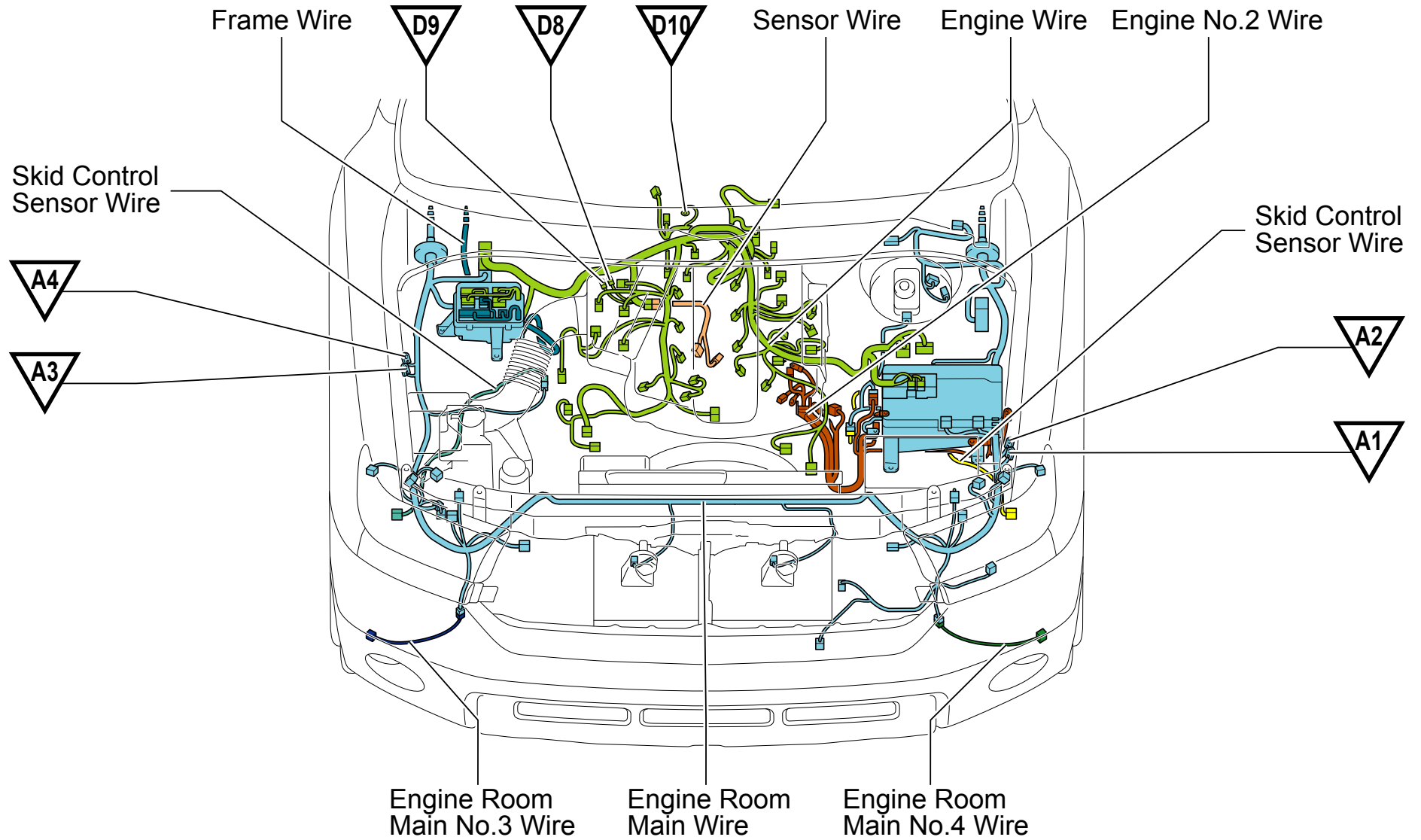



Position of Parts in Engine Compartment <1GR-FE>

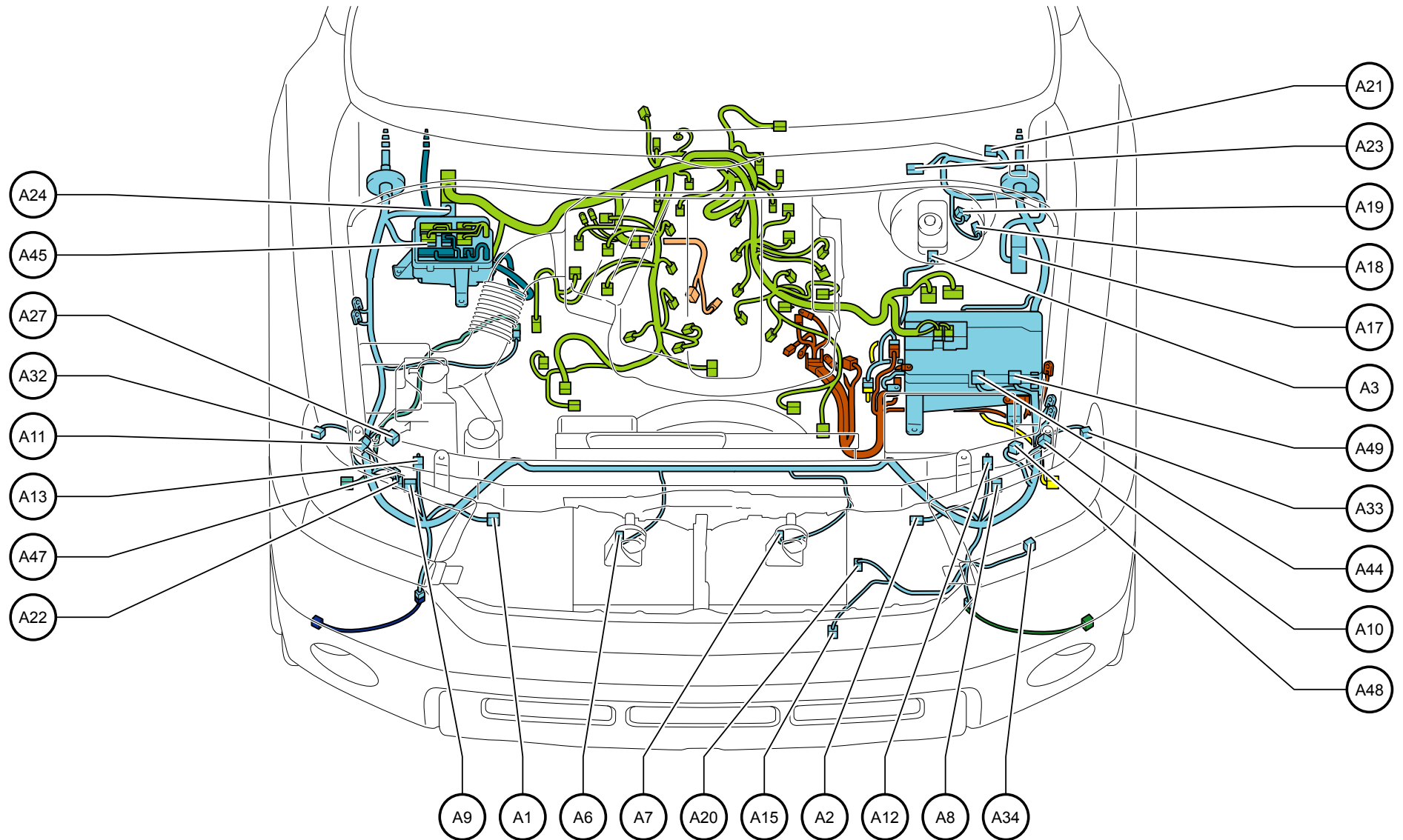

Position of Parts in Engine Compartment <1GR-FE>

---

- A 1 Front Airbag Sensor RH
- A 2 Front Airbag Sensor LH
- A 3 Brake Fluid Level Warning Switch
- A 6 High Pitched Horn
- A 7 Low Pitched Horn
- A 8 Headlight LH (High)
- A 9 Headlight RH (High)
- A 10 Headlight LH (Low)
- A 11 Headlight RH (Low)
- A 12 Front Parking Light LH , Front Turn Signal Light LH
- A 13 Front Parking Light RH , Front Turn Signal Light RH
- A 15 Ambient Temperature Sensor
- A 17 Skid Control ECU with Actuator
- A 18 Active Brake Booster
- A 19 Pedal Stroke Speed Sensor
- A 20 A/C Pressure Switch
- A 21 Windshield Wiper Motor
- A 22 Washer Motor
- A 23 Front Wiper Deicer
- A 24 Engine Control Module
- A 27 Washer Fluid Level Sensor
- A 32 Front Side Marker Light RH
- A 33 Front Side Marker Light LH
- A 34 Wireless Door Lock Buzzer
- A 44 Junction Connector
- A 45 Junction Connector
- A 47 Headlight Levering Motor RH
- A 48 Headlight Levering Motor LH
- A 49 Junction Connector

Position of Parts in Engine Compartment <1GR-FE>

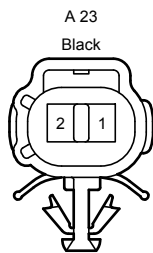
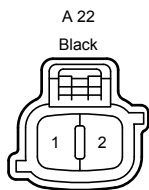
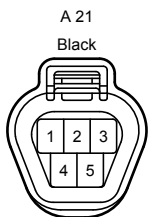
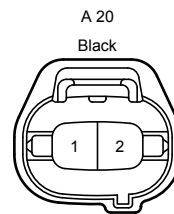
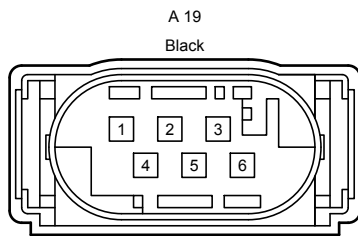
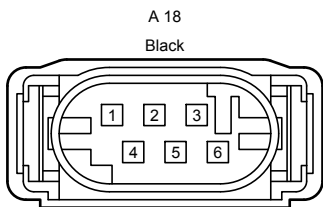
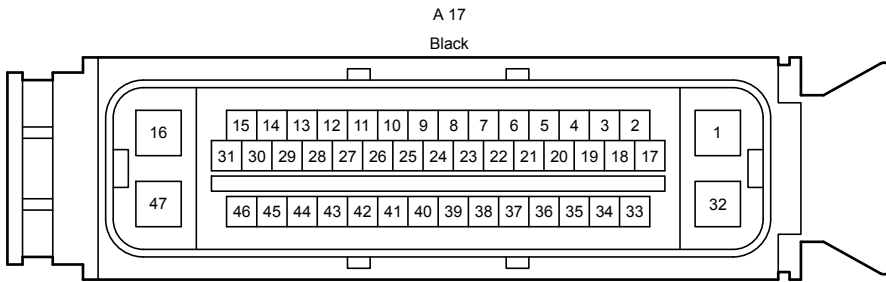
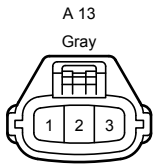
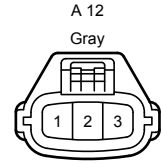
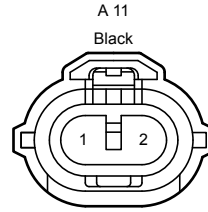
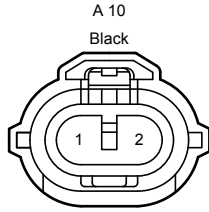
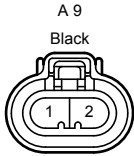
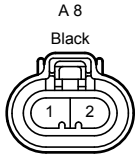
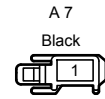
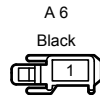
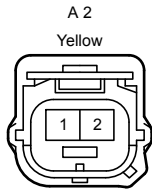
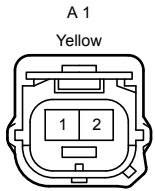

Position of Parts in Engine Compartment <1GR-FE>

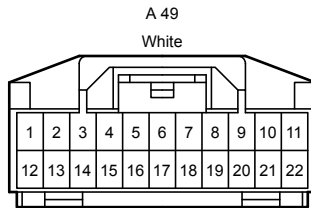
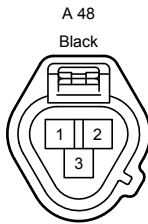
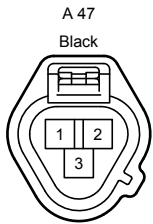
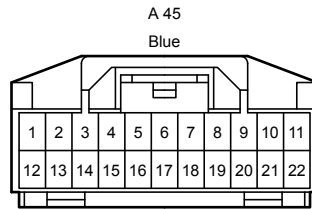
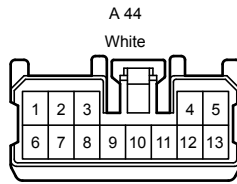
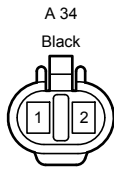
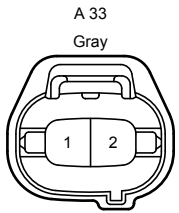
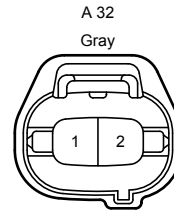
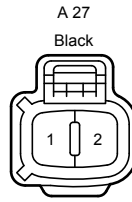
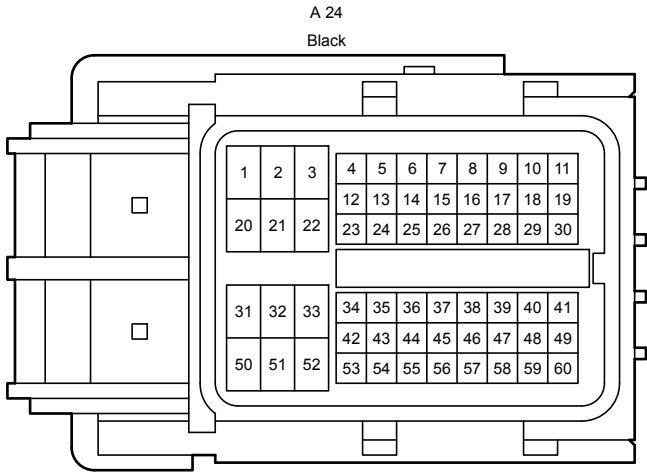

Position of Parts in Engine Compartment <1GR-FE>

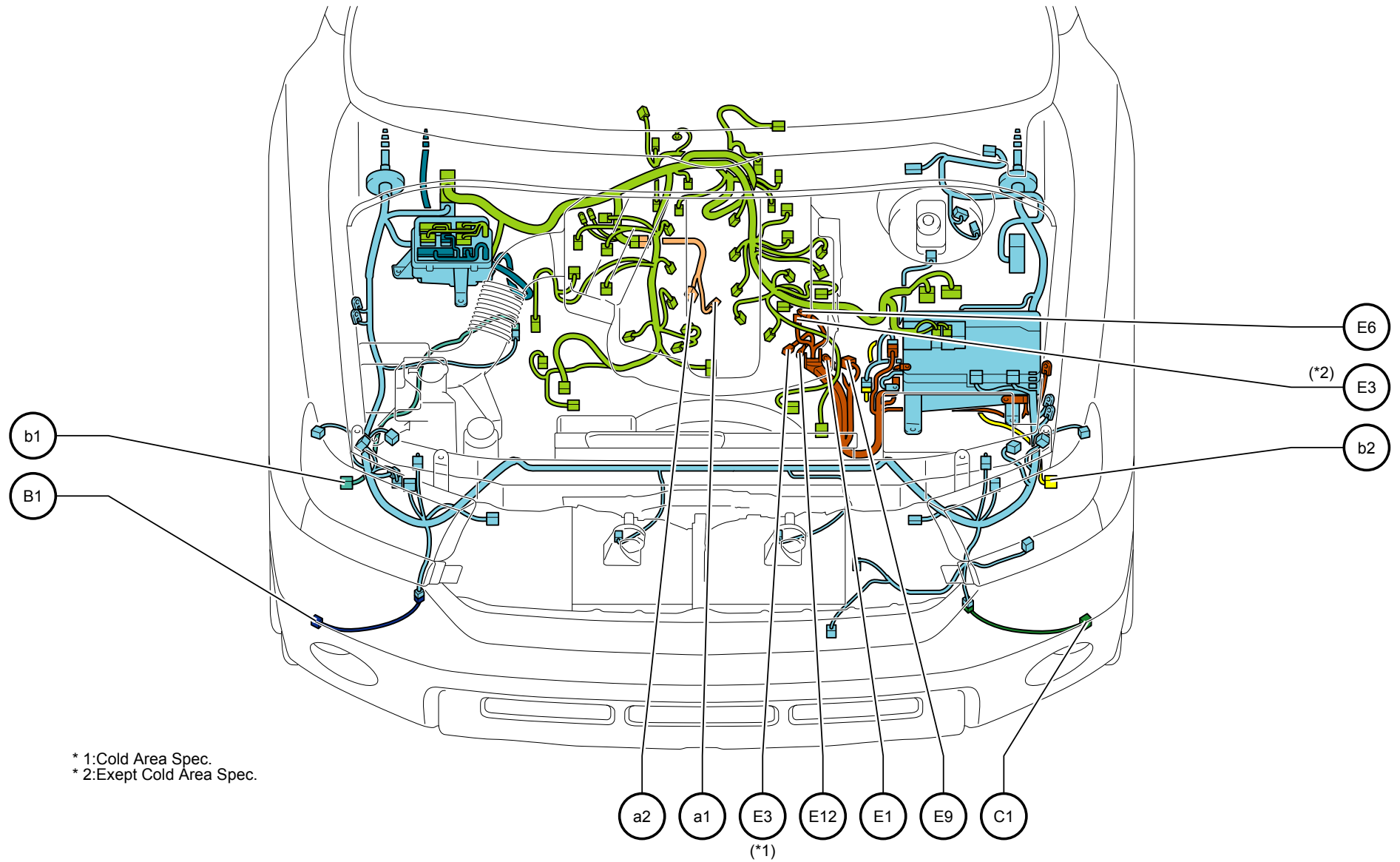

\* 1: Cold Area Spec.  
\* 2: Exept Cold Area Spec.

**Position of Parts in Engine Compartment <1GR-FE>**

---

B 1 No.1 Ultrasonic Sensor (Front Right)

C 1 No.1 Ultrasonic Sensor (Front Left)

E 1 Generator

E 3 Starter

E 6 Starter

E 9 Generator

E 12 Starter

a 1 Knock Sensor (Bank 2)

a 2 Knock Sensor (Bank 1)

b 1 Front Speed Sensor RH

b 2 Front Speed Sensor LH

Position of Parts in Engine Compartment <1GR-FE>

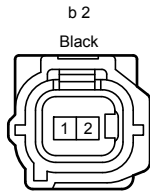
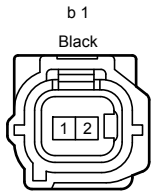
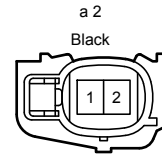
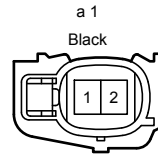
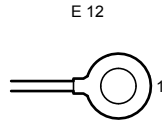
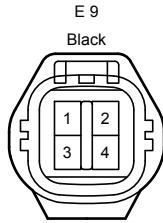
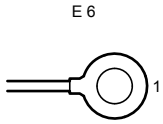
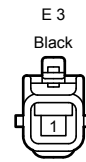
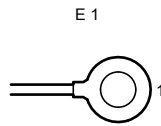
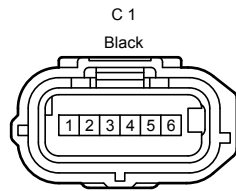
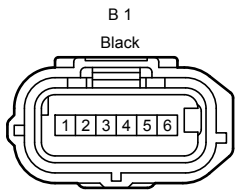

Position of Parts in Engine Compartment <1GR-FE>

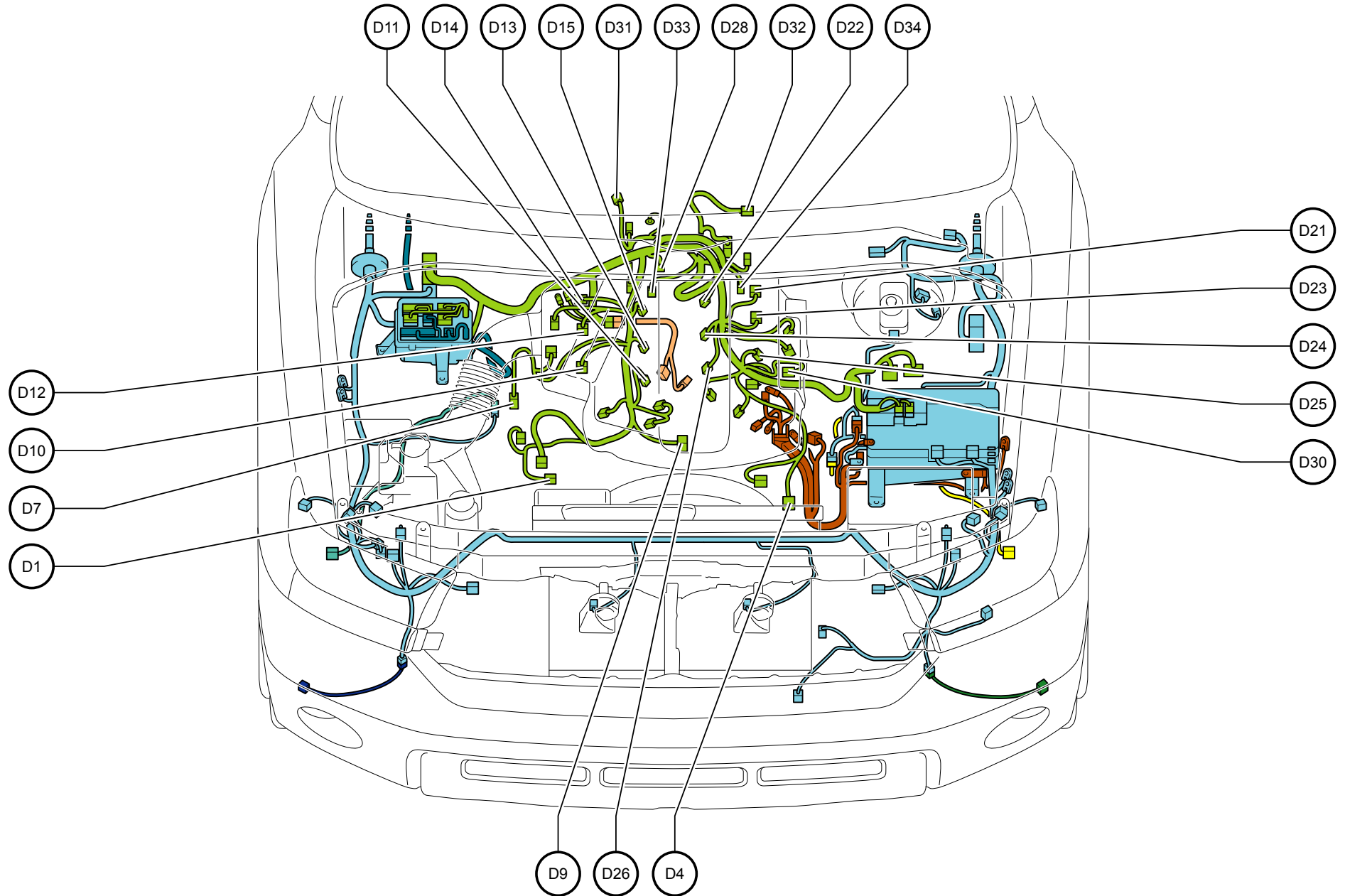



Position of Parts in Engine Compartment <1GR-FE>

---

- D 1 Oil Pressure Switch
- D 4 Crankshaft Position Sensor
- D 7 Mass Air Flow Meter
- D 9 Throttle Position Sensor
- D 10 Ignition Coil (No.1)
- D 11 Fuel Injector (No.1)
- D 12 Ignition Coil (No.3)
- D 13 Fuel Injector (No.3)
- D 14 Ignition Coil (No.5)
- D 15 Fuel Injector (No.5)
- D 21 Ignition Coil (No.6)
- D 22 Fuel Injector (No.6)
- D 23 Ignition Coil (No.4)
- D 24 Fuel Injector (No.4)
- D 25 Ignition Coil (No.2)
- D 26 Fuel Injector (No.2)
- D 28 Engine Coolant Temperature Sensor
- D 30 Purge VSV
- D 31 Heated Oxygen Sensor (Bank 1 Sensor 2)
- D 32 Heated Oxygen Sensor (Bank 2 Sensor 2)
- D 33 Air Fuel Ratio Sensor (Bank 1 Sensor 1)
- D 34 Air Fuel Ratio Sensor (Bank 2 Sensor 1)

Position of Parts in Engine Compartment <1GR-FE>

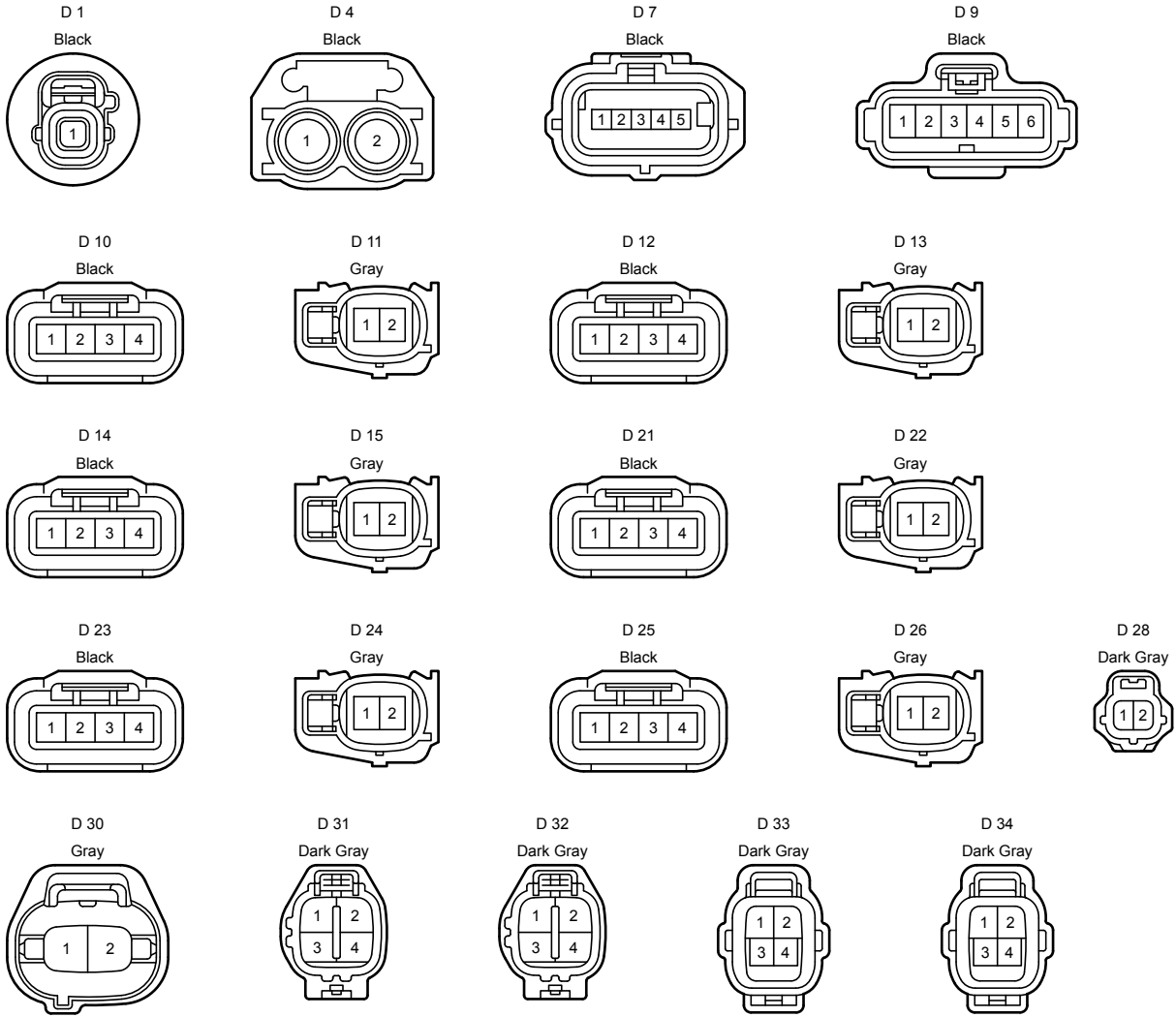

Position of Parts in Engine Compartment <1GR-FE>

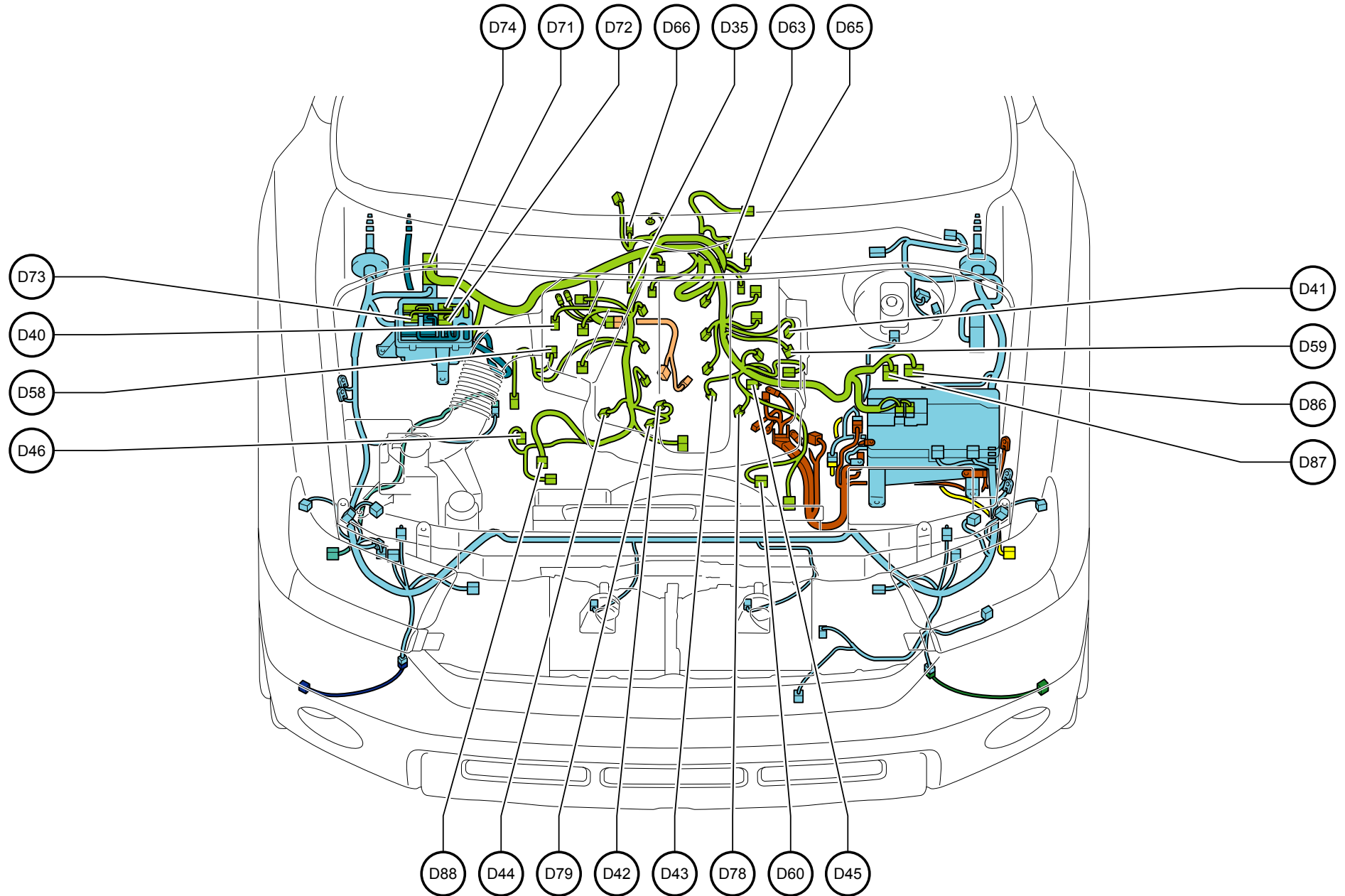

- D 35 Park/Neutral Position Switch
- D 40 VVT Sensor (Bank 1 Exhaust Side)
- D 41 VVT Sensor (Bank 2 Exhaust Side)
- D 42 Camshaft Timing Oil Control Valve (Bank 1 Intake Side)
- D 43 Camshaft Timing Oil Control Valve (Bank 2 Intake Side)
- D 44 Camshaft Timing Oil Control Valve (Bank 1 Exhaust Side)
- D 45 Camshaft Timing Oil Control Valve (Bank 2 Exhaust Side)
- D 46 Power Steering Oil Pressure Sensor
- D 58 Air Switching Valve (Bank 1)
- D 59 Air Switching Valve (Bank 2)
- D 60 A/C Compressor
- D 63 Automatic Transmission
- D 65 Transmission Revolution Sensor (Turbine)
- D 66 Transmission Revolution Sensor (Electronically Controlled Transmission)
- D 71 Junction Connector
- D 72 Junction Connector
- D 73 Junction Connector
- D 74 Engine Control Module
- D 78 VVT Sensor (Bank 2 Intake Side)
- D 79 VVT Sensor (Bank 1 Intake Side)
- D 86 Air Injection Control Driver
- D 87 Air Injection Control Driver
- D 88 Air Pump

Position of Parts in Engine Compartment <1GR-FE>

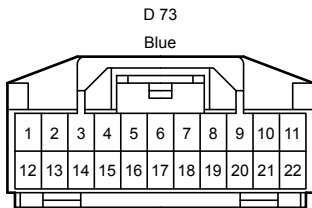
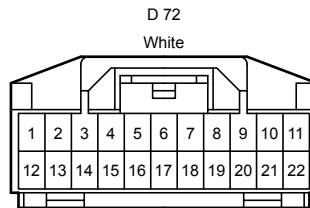
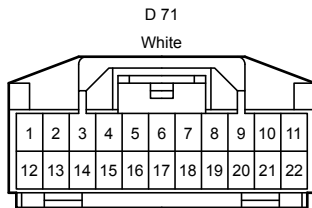
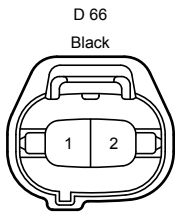
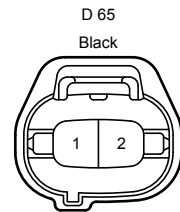
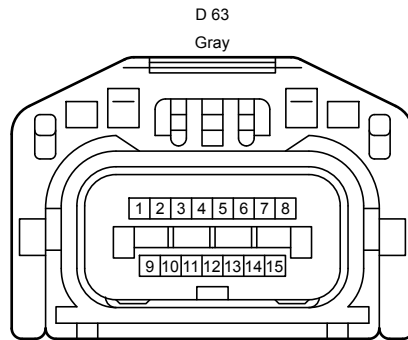
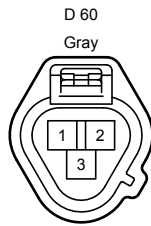
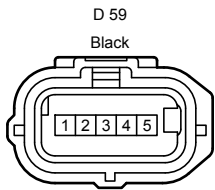
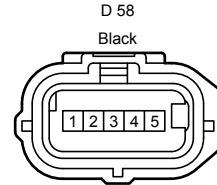
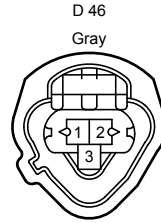
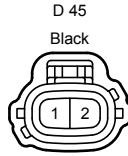
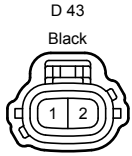
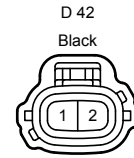
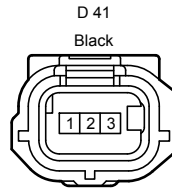
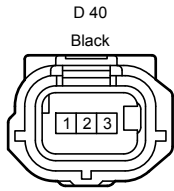
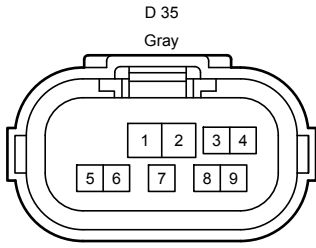

Position of Parts in Engine Compartment <1GR-FE>

D 74  
Black

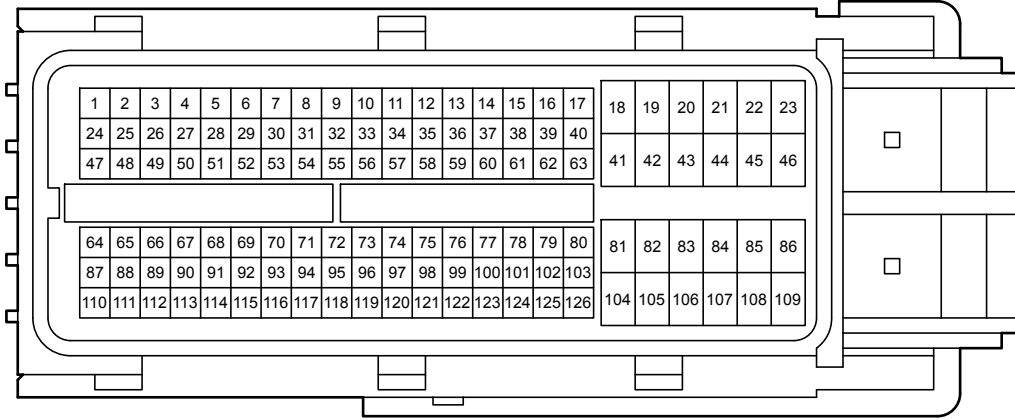

D 78  
Black

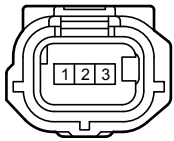

D 79  
Black

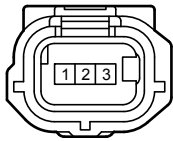

D 86  
Black

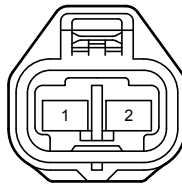

D 87  
Black

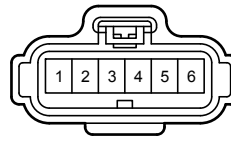

D 88  
Gray



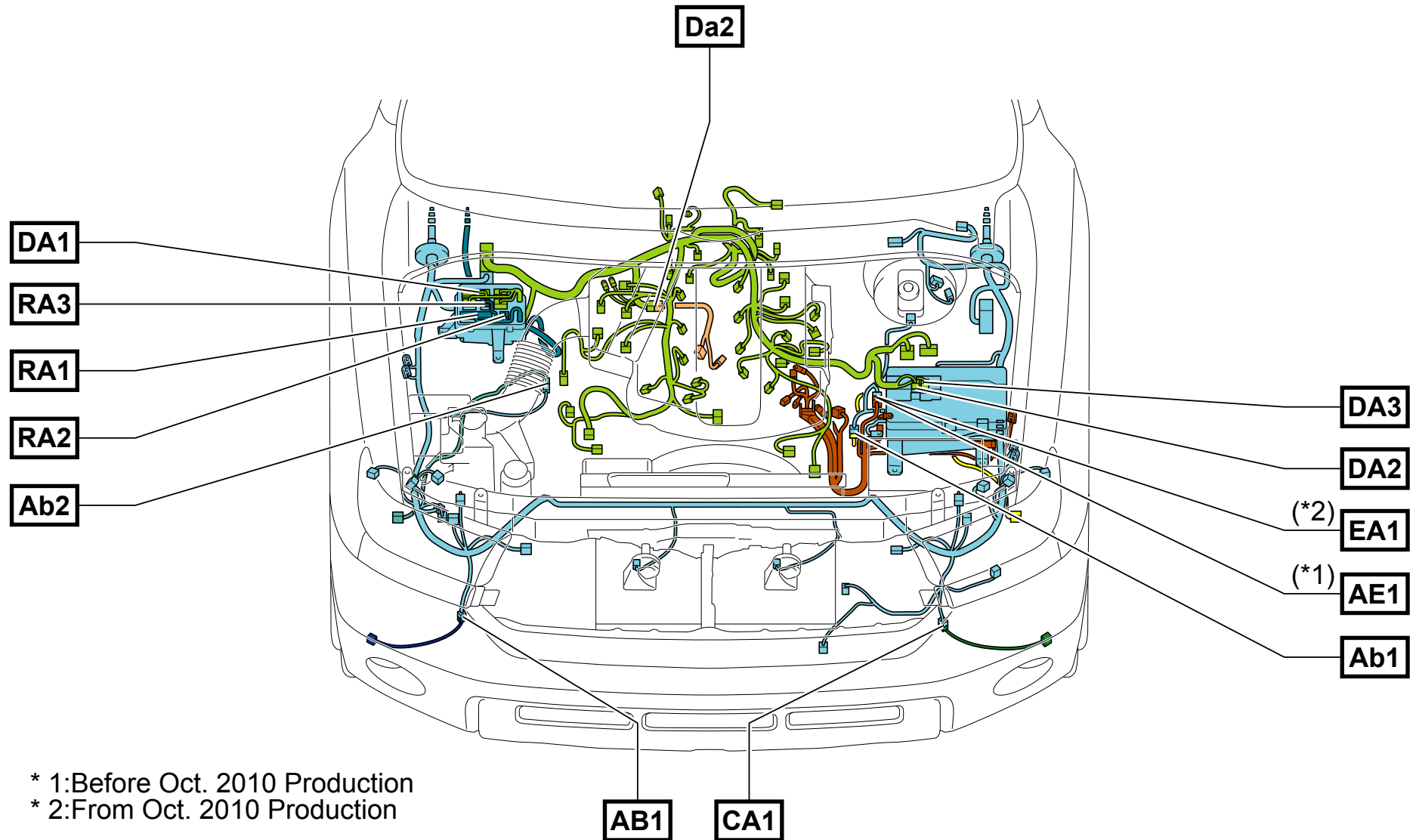

Wire and Wire in Engine Compartment <1GR-FE>

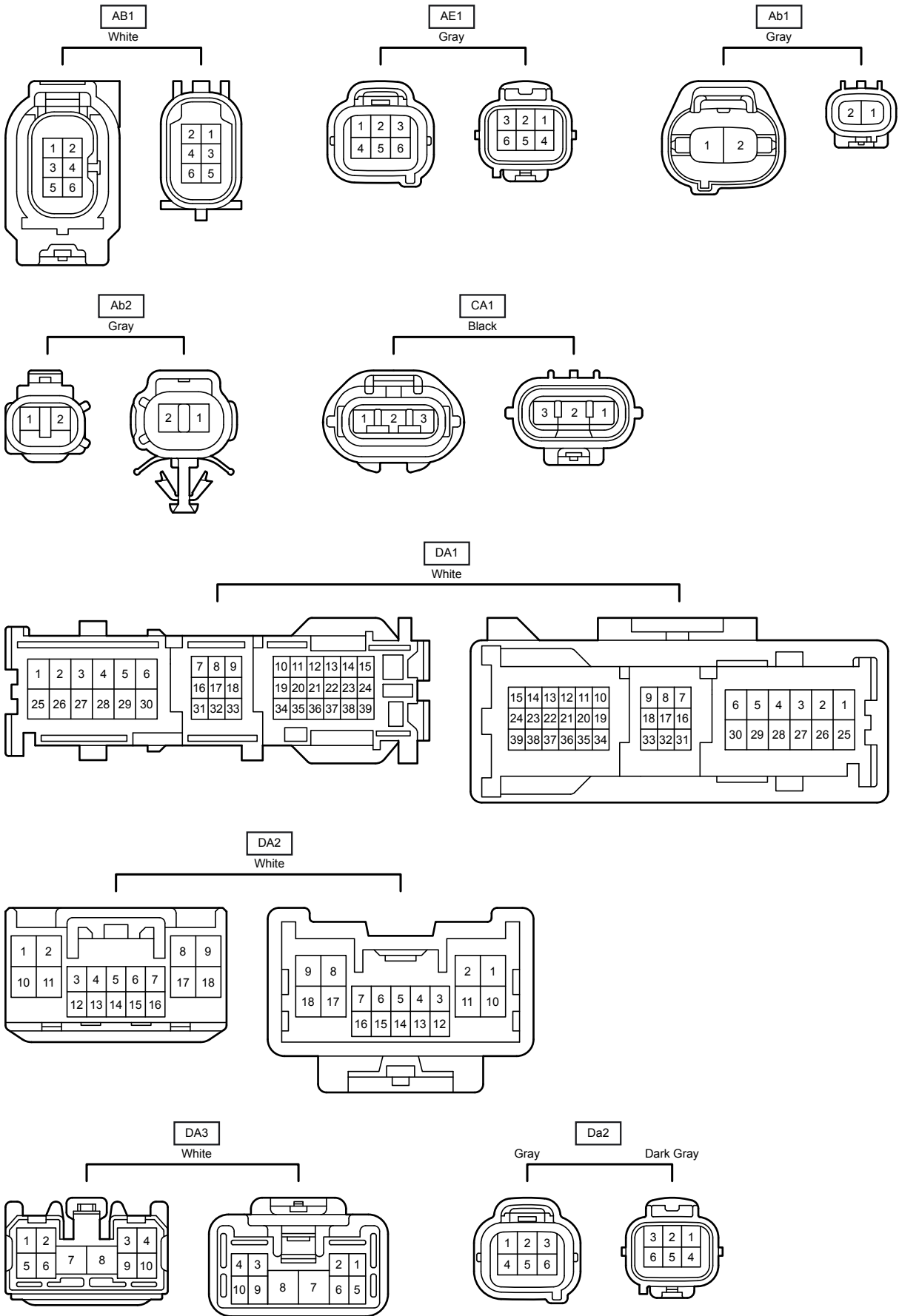



Wire and Wire in Engine Compartment <1GR-FE>

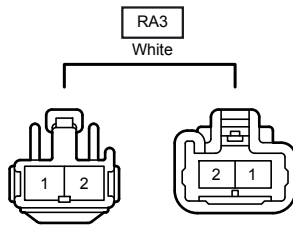
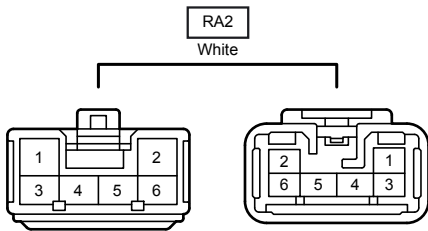
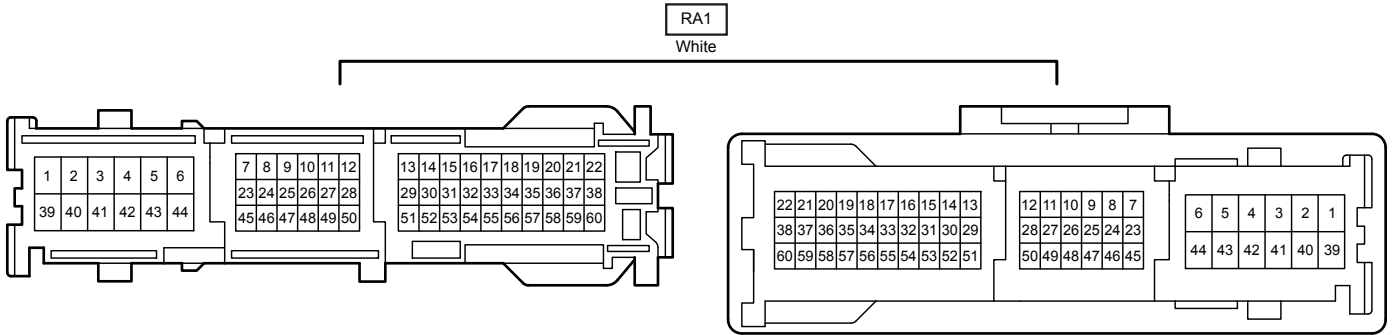
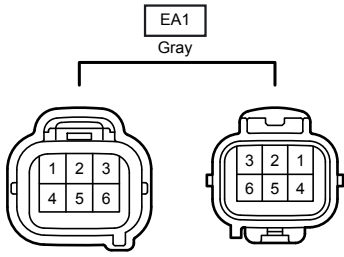

Ground Points in Engine Compartment <1UR-FE>

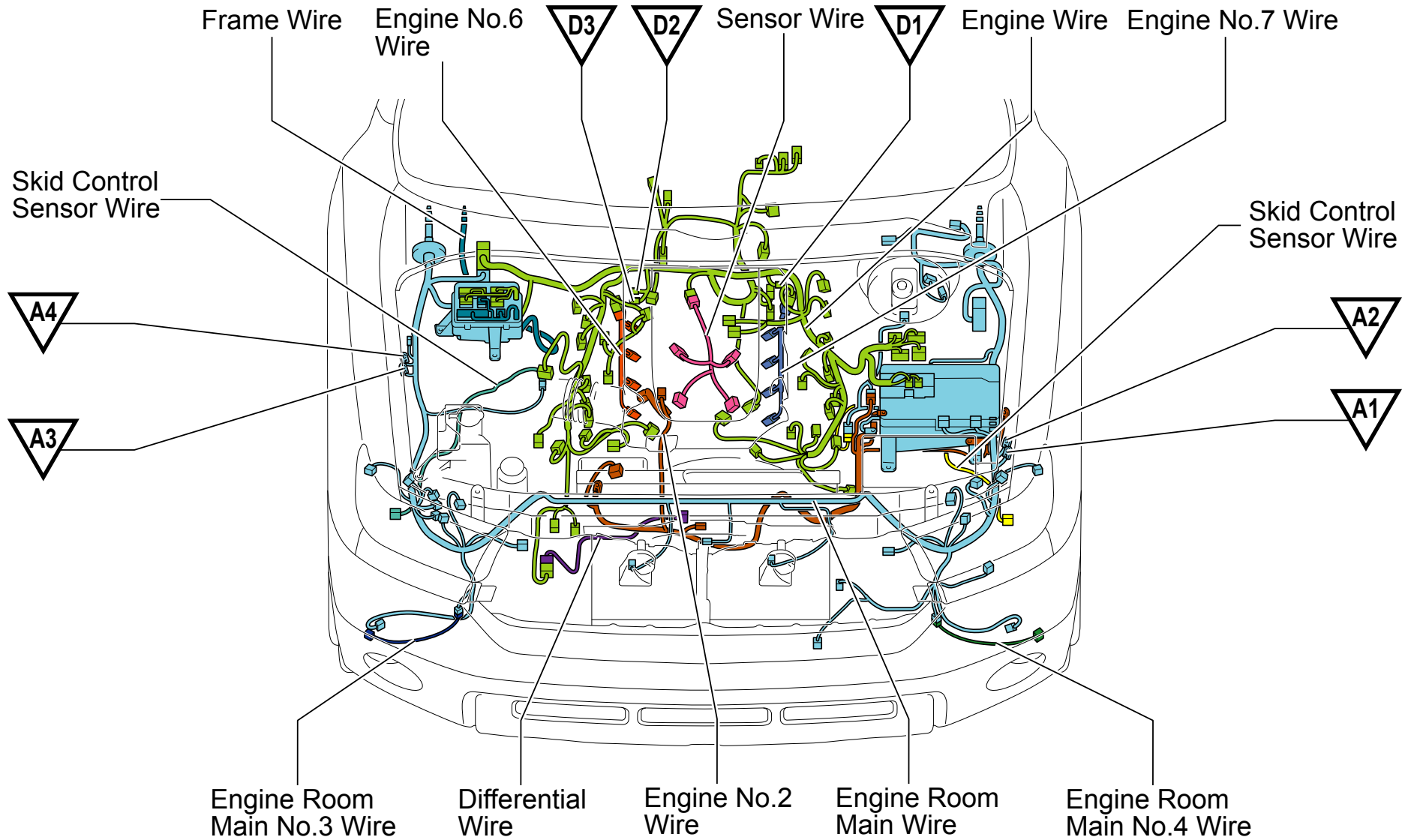

Position of Parts in Engine Compartment <1UR-FE>

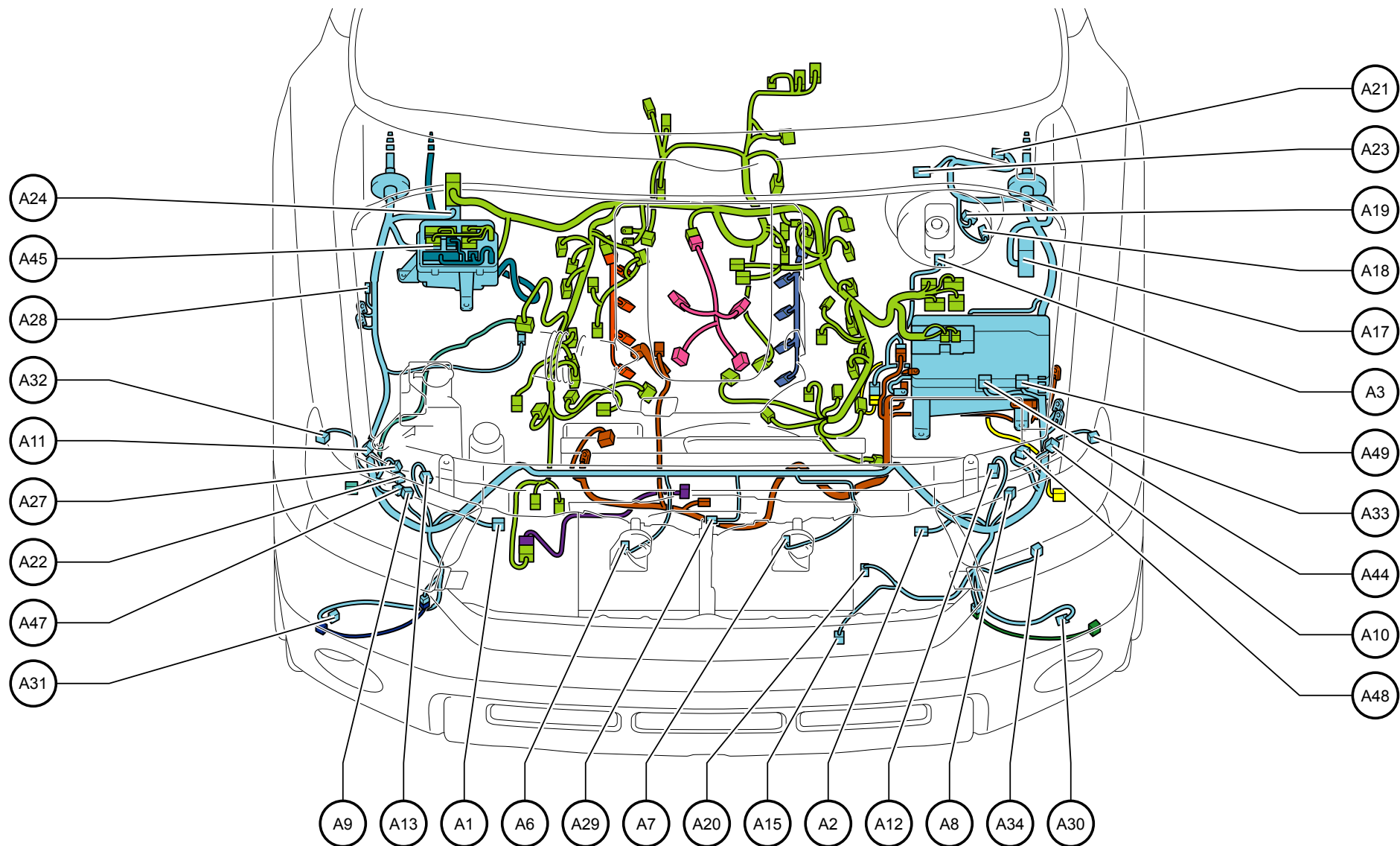

Position of Parts in Engine Compartment <1UR-FE>

---

- A 1 Front Airbag Sensor RH
- A 2 Front Airbag Sensor LH
- A 3 Brake Fluid Level Warning Switch
- A 6 High Pitched Horn
- A 7 Low Pitched Horn
- A 8 Headlight LH (High)
- A 9 Headlight RH (High)
- A 10 Headlight LH (Low)
- A 11 Headlight RH (Low)
- A 12 Front Parking Light LH , Front Turn Signal Light LH
- A 13 Front Parking Light RH , Front Turn Signal Light RH
- A 15 Ambient Temperature Sensor
- A 17 Skid Control ECU with Actuator
- A 18 Active Brake Booster
- A 19 Pedal Stroke Speed Sensor
- A 20 A/C Pressure Switch
- A 21 Windshield Wiper Motor
- A 22 Washer Motor
- A 23 Front Wiper Deicer
- A 24 Engine Control Module
- A 27 Washer Fluid Level Sensor
- A 28 Security Horn
- A 29 Engine Hood Courtesy Switch
- A 30 Fog Light LH
- A 31 Fog Light RH
- A 32 Front Side Marker Light RH
- A 33 Front Side Marker Light LH
- A 34 Wireless Door Lock Buzzer
- A 44 Junction Connector
- A 45 Junction Connector
- A 47 Headlight Levering Motor RH
- A 48 Headlight Levering Motor LH
- A 49 Junction Connector

Position of Parts in Engine Compartment <1UR-FE>

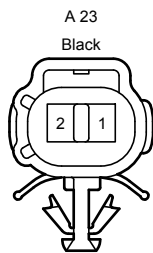
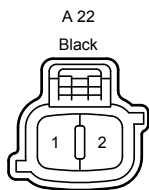
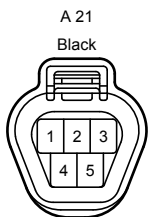
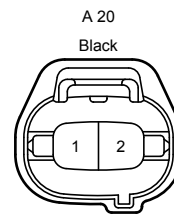
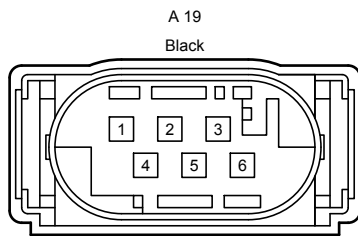
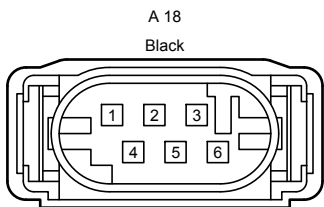
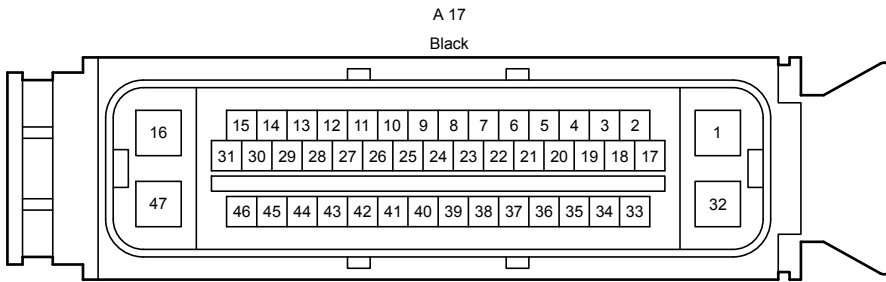
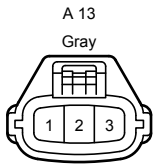
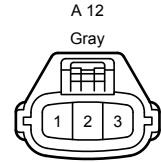
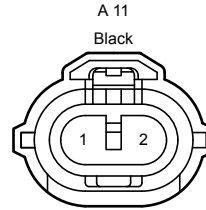
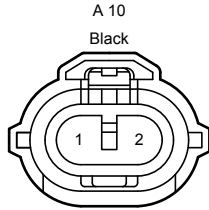
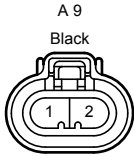
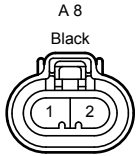
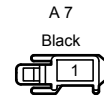
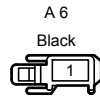
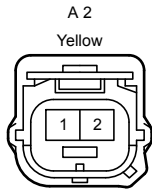
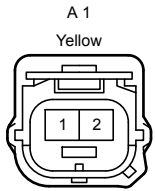

Position of Parts in Engine Compartment <1UR-FE>

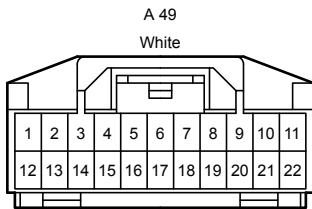
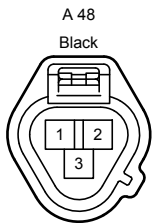
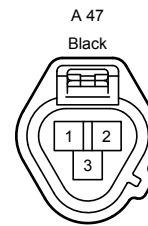
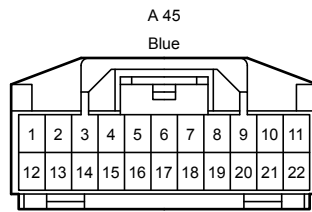
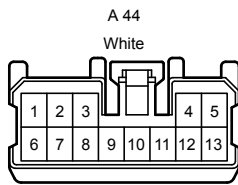
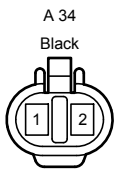
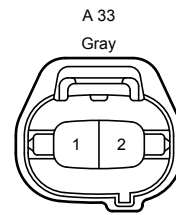
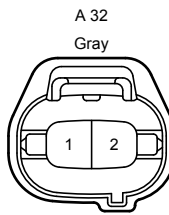
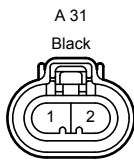
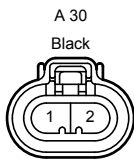
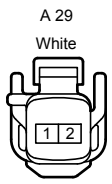
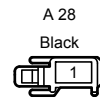
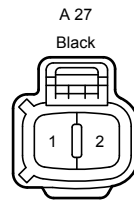
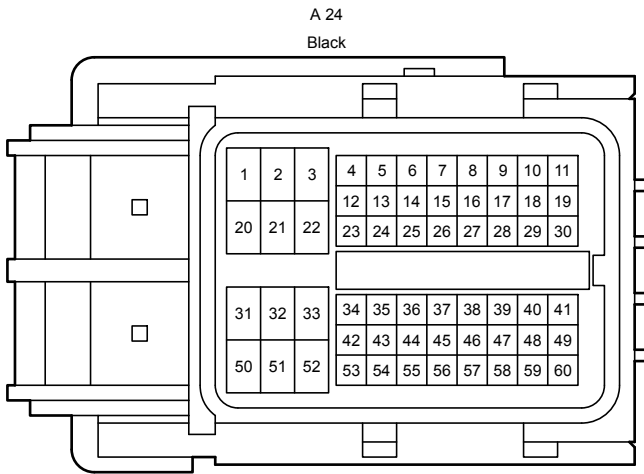

Position of Parts in Engine Compartment <1UR-FE>

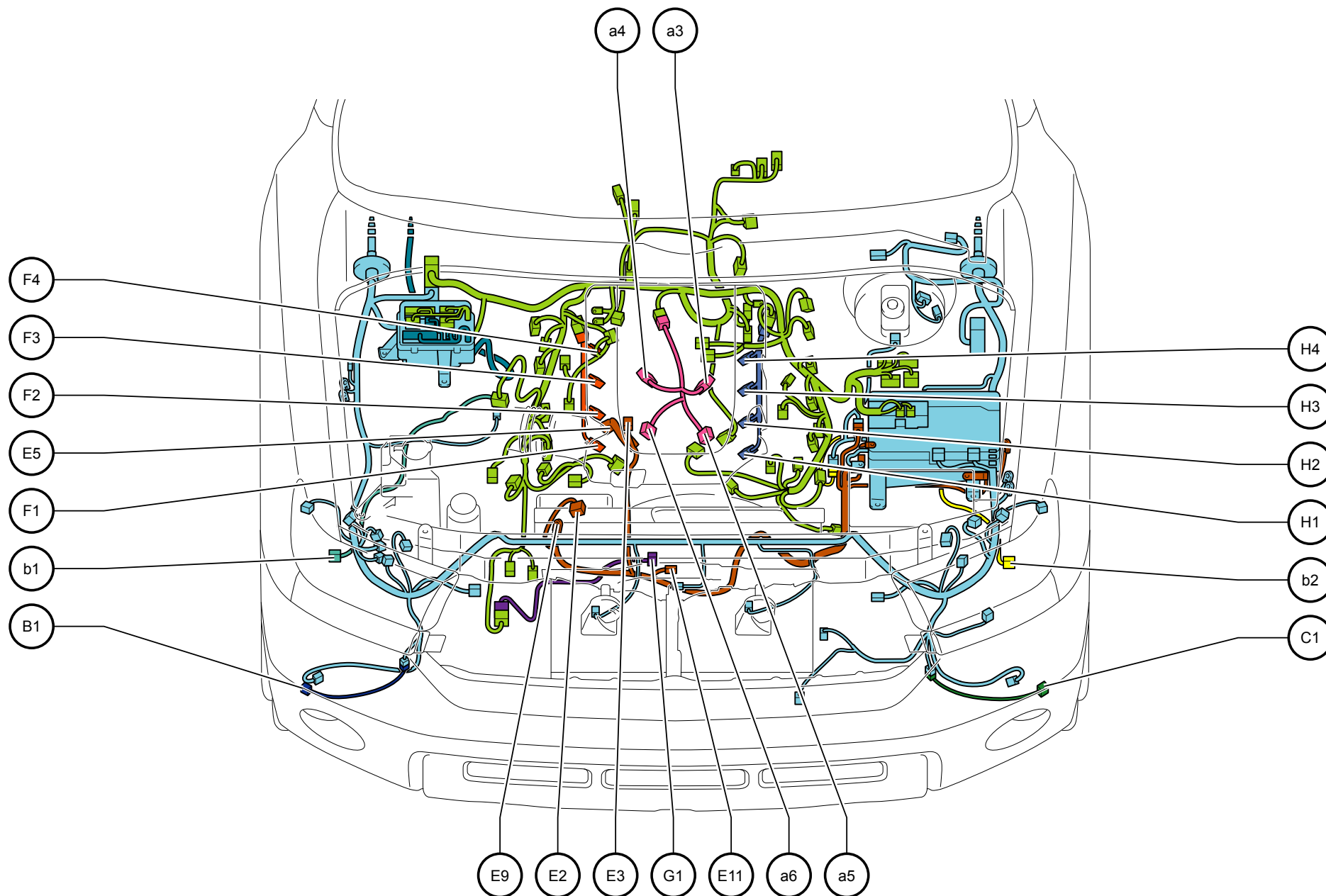

Position of Parts in Engine Compartment <1UR-FE>

---

B 1 No.1 Ultrasonic Sensor (Front Right)

C 1 No.1 Ultrasonic Sensor (Front Left)

E 2 Generator

E 3 Starter

E 5 Starter

E 9 Generator

E 11 Oil Pressure Sender

F 1 Fuel Injector (No.2)

F 2 Fuel Injector (No.4)

F 3 Fuel Injector (No.6)

F 4 Fuel Injector (No.8)

G 1 ADD Actuator

H 1 Fuel Injector (No.1)

H 2 Fuel Injector (No.3)

H 3 Fuel Injector (No.5)

H 4 Fuel Injector (No.7)

a 3 Knock Sensor (Bank 1 Sensor 2)

a 4 Knock Sensor (Bank 2 Sensor 2)

a 5 Knock Sensor (Bank 1 Sensor 1)

a 6 Knock Sensor (Bank 2 Sensor 1)

b 1 Front Speed Sensor RH

b 2 Front Speed Sensor LH



Position of Parts in Engine Compartment <1UR-FE>

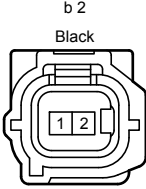
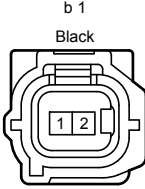
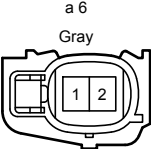
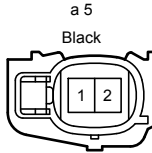
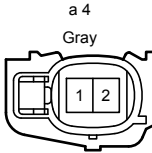
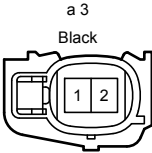
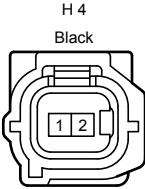
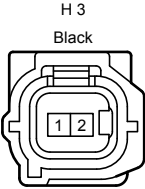
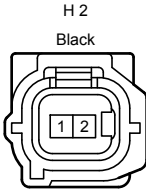
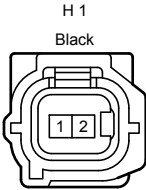
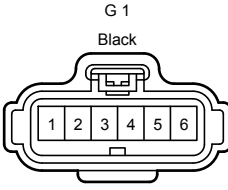
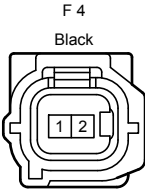
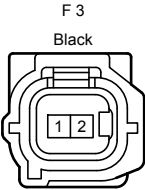
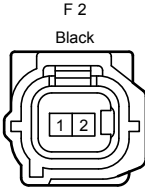
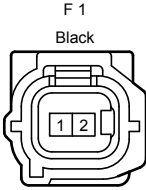
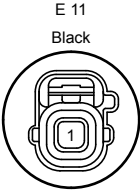
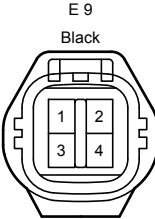
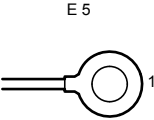
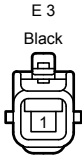
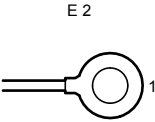
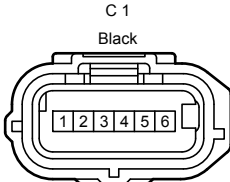
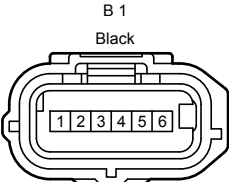

Position of Parts in Engine Compartment <1UR-FE>

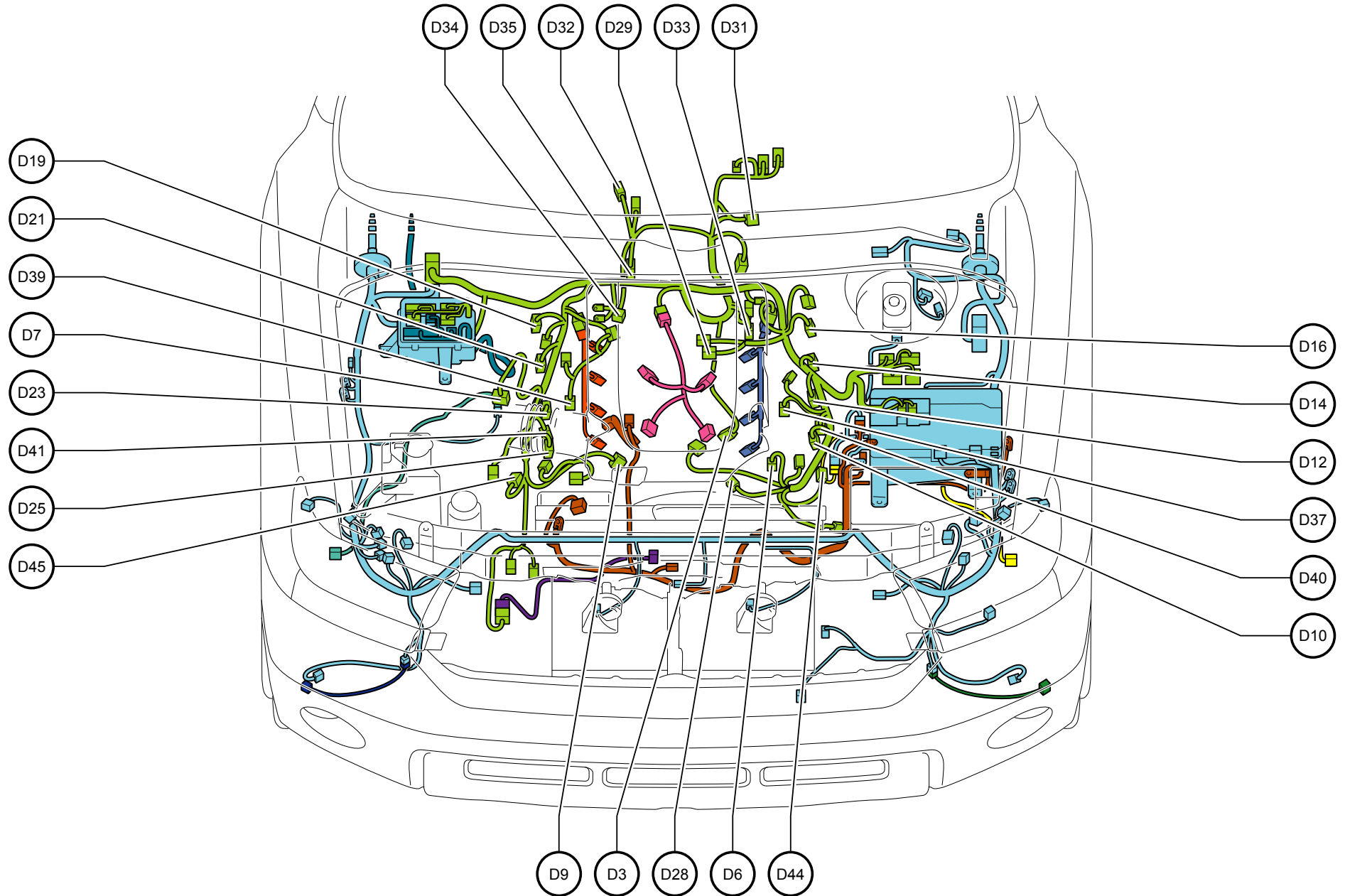

- D 3 Crankshaft Position Sensor
- D 6 Camshaft Position Sensor
- D 7 Mass Air Flow Meter
- D 9 Throttle Position Sensor
- D 10 Ignition Coil (No.1)
- D 12 Ignition Coil (No.3)
- D 14 Ignition Coil (No.5)
- D 16 Ignition Coil (No.7)
- D 19 Ignition Coil (No.8)
- D 21 Ignition Coil (No.6)
- D 23 Ignition Coil (No.4)
- D 25 Ignition Coil (No.2)
- D 28 Engine Coolant Temperature Sensor
- D 29 Purge VSV
- D 31 Heated Oxygen Sensor (Bank 1 Sensor 2)
- D 32 Heated Oxygen Sensor (Bank 2 Sensor 2)
- D 33 Air Fuel Ratio Sensor (Bank 1 Sensor 1)
- D 34 Air Fuel Ratio Sensor (Bank 2 Sensor 1)
- D 35 Park/Neutral Position Switch
- D 37 VVT Sensor (Bank 1 Intake Side)
- D 39 VVT Sensor (Bank 2 Intake Side)
- D 40 VVT Sensor (Bank 1 Exhaust Side)
- D 41 VVT Sensor (Bank 2 Exhaust Side)
- D 44 Camshaft Timing Oil Control Valve (Bank 1 Exhaust Side)
- D 45 Camshaft Timing Oil Control Valve (Bank 2 Exhaust Side)

Position of Parts in Engine Compartment <1UR-FE>

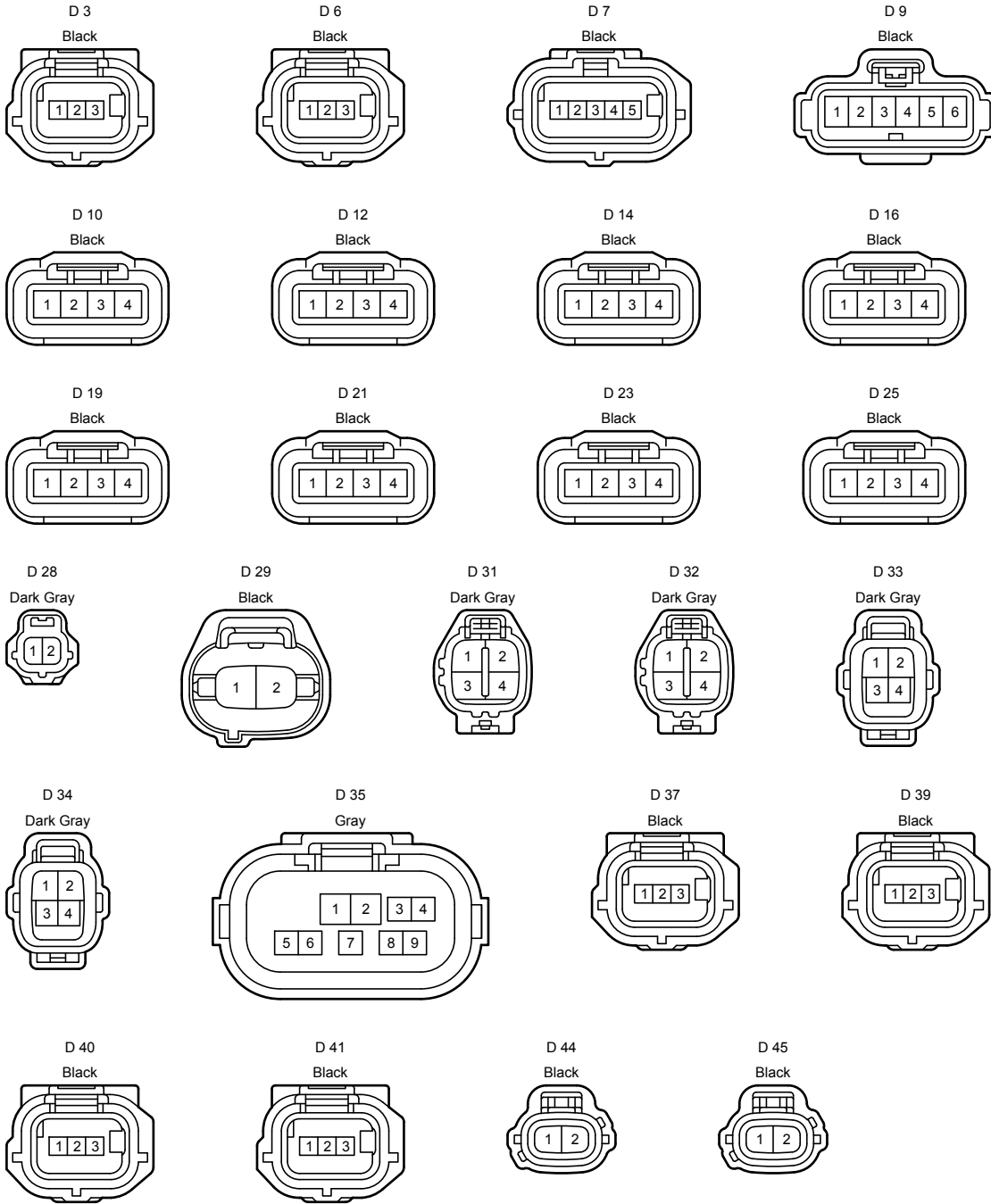

Position of Parts in Engine Compartment <1UR-FE>

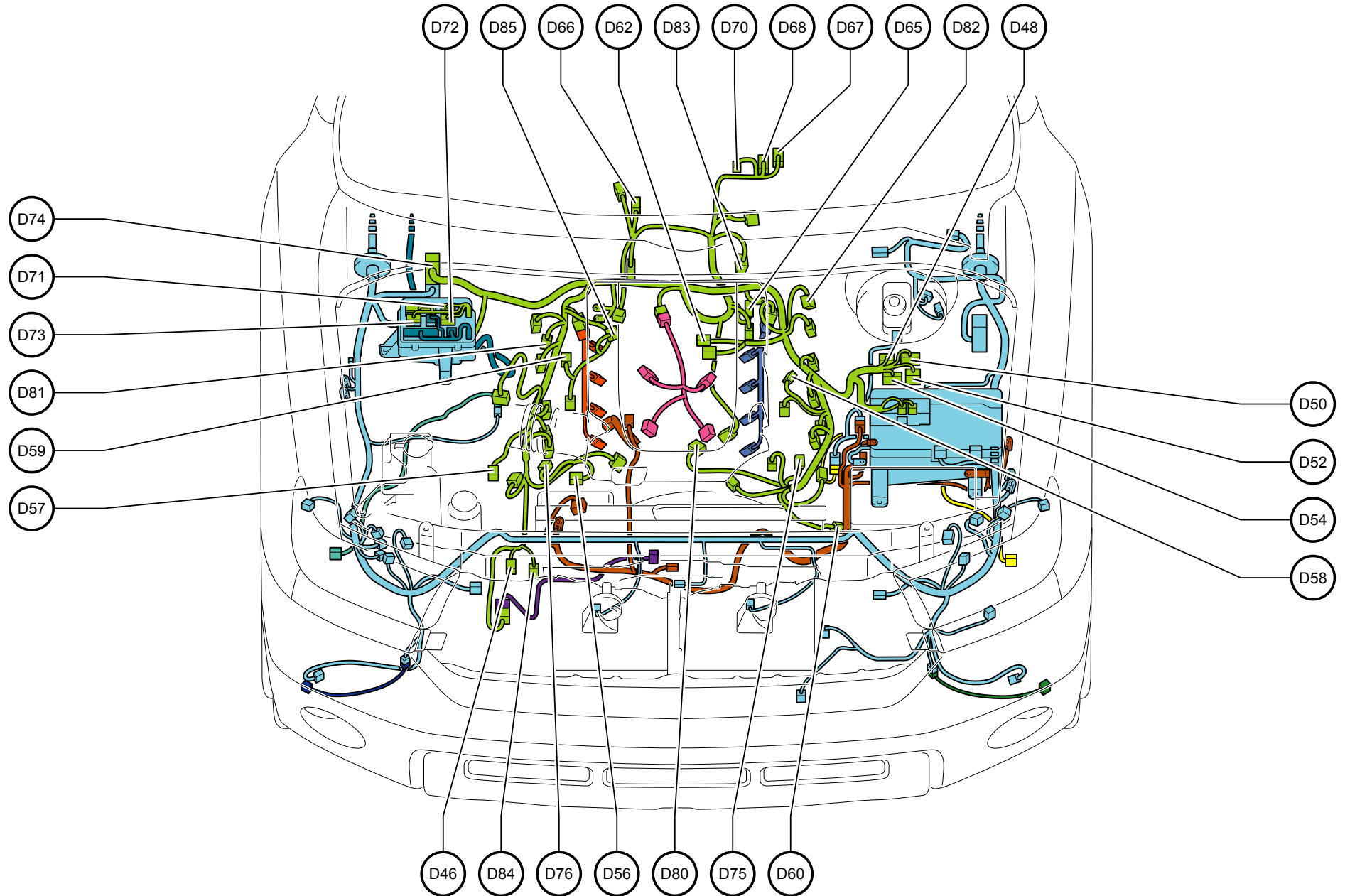

- D 46 Power Steering Oil Pressure Sensor
- D 48 Air Injection Control Driver (Bank 1)
- D 50 Air Injection Control Driver (Bank 1)
- D 52 Air Injection Control Driver (Bank 2)
- D 54 Air Injection Control Driver (Bank 2)
- D 56 Air Pump (Bank 1)
- D 57 Air Pump (Bank 2)
- D 58 Air Switching Valve (Bank 1)
- D 59 Air Switching Valve (Bank 2)
- D 60 A/C Compressor
- D 62 ACIS VSV
- D 65 Transmission Revolution Sensor (Turbine)
- D 66 Transmission Revolution Sensor (Electronically Controlled Transmission)
- D 67 Transfer Shift Actuator
- D 68 Transfer Shift Actuator
- D 70 Transfer Shift Actuator
- D 71 Junction Connector
- D 72 Junction Connector
- D 73 Junction Connector
- D 74 Engine Control Module
- D 75 Camshaft Timing Oil Control Valve (Bank 1 Intake side)
- D 76 Camshaft Timing Oil Control Valve (Bank 2 Intake Side)
- D 80 Intake Manifold Vacuum Sensor
- D 81 Noise Filter (Ignition Bank 2)
- D 82 Noise Filter (Ignition Bank 1)
- D 83 Automatic Transmission
- D 84 Vane Pump Assembly
- D 85 EGR Control Valve Sub-Assembly

Position of Parts in Engine Compartment <1UR-FE>

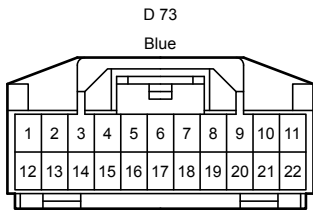
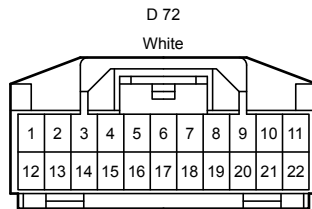
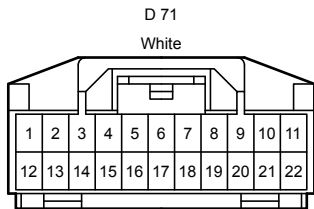
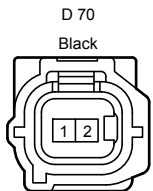
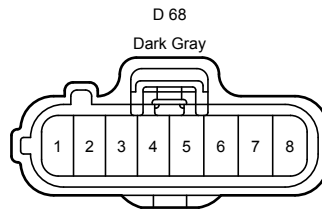
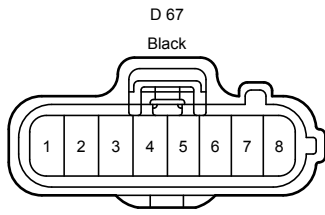
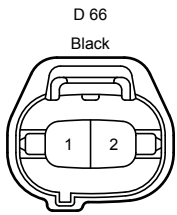
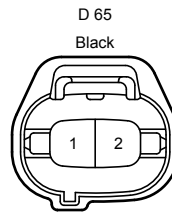
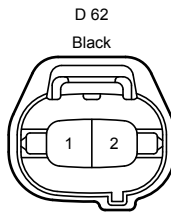
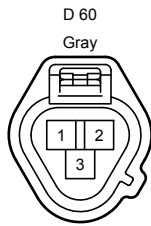
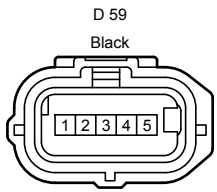
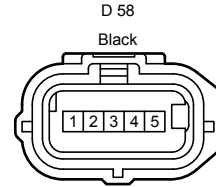
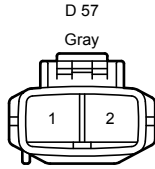
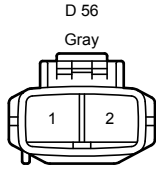
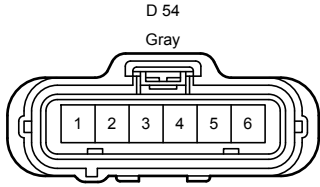
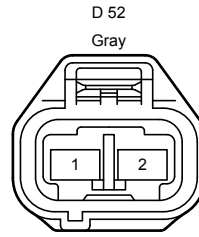
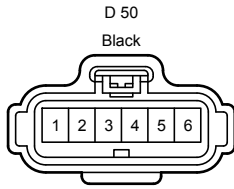
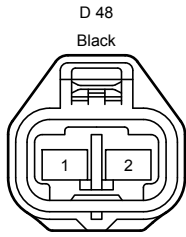
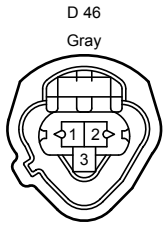

Position of Parts in Engine Compartment <1UR-FE>

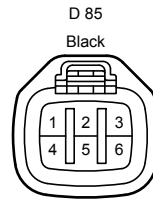
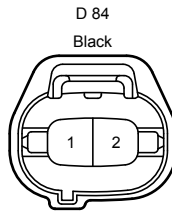
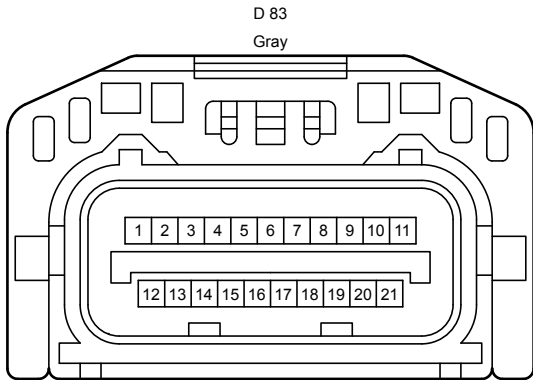
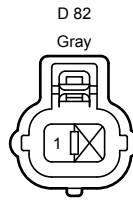
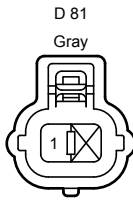
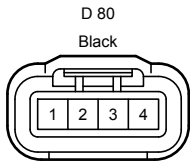
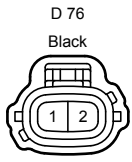
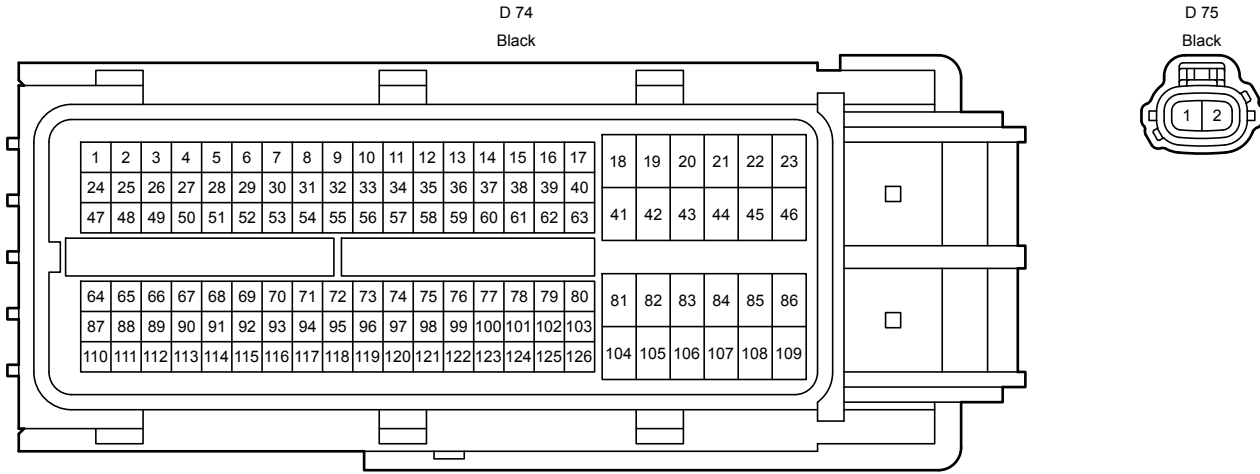



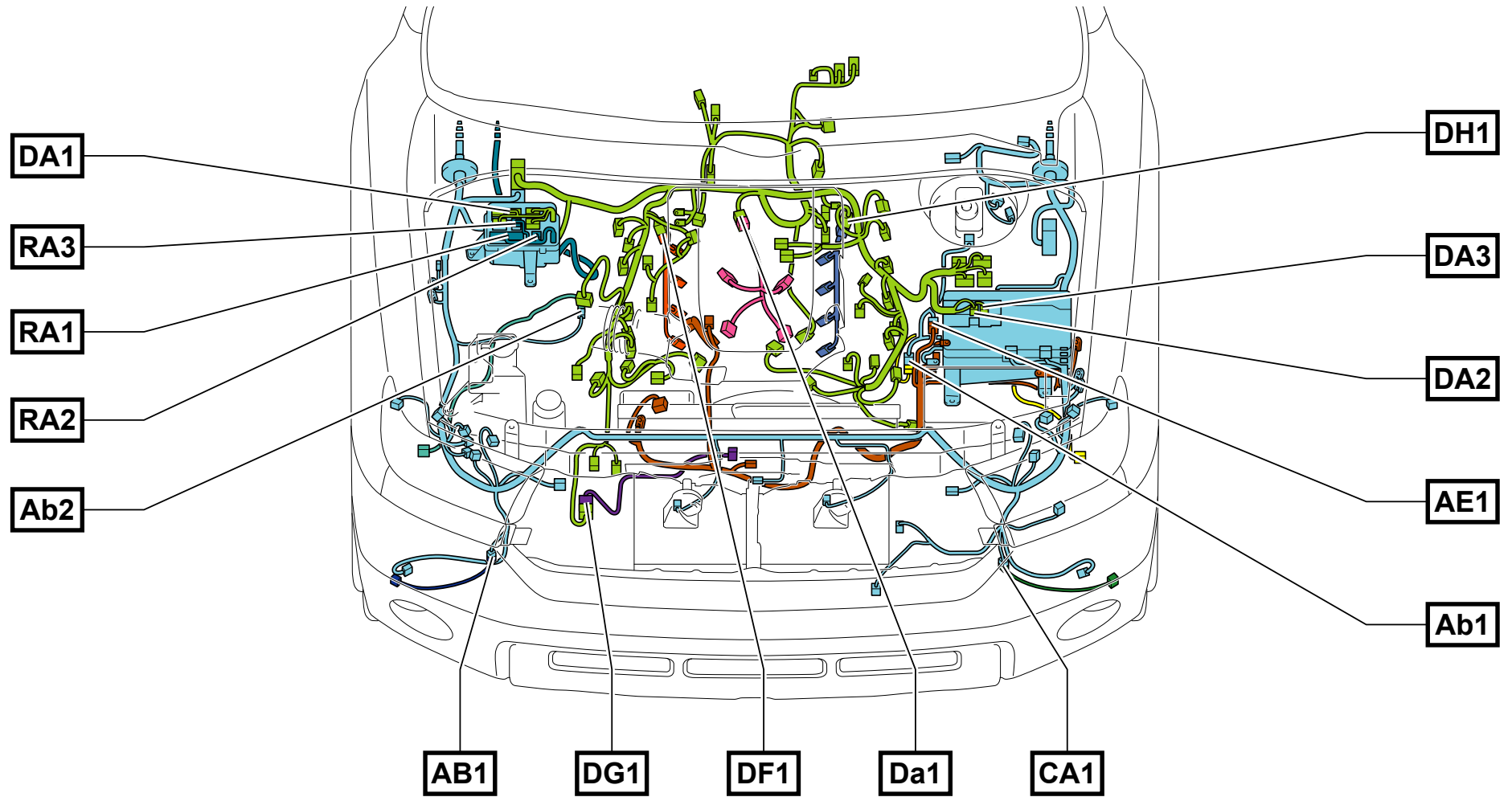

Wire and Wire in Engine Compartment <1UR-FE>

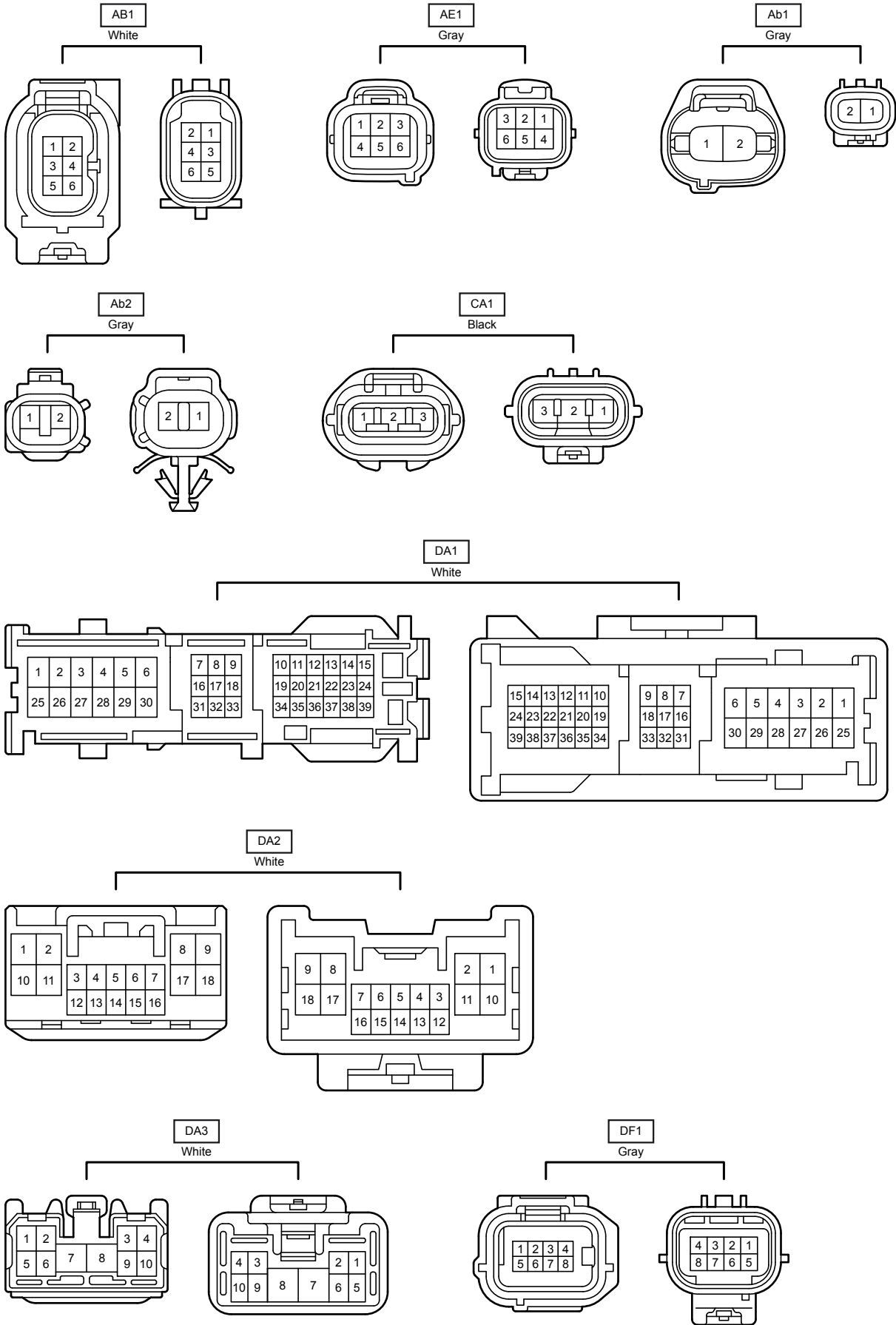

Wire and Wire in Engine Compartment <1UR-FE>

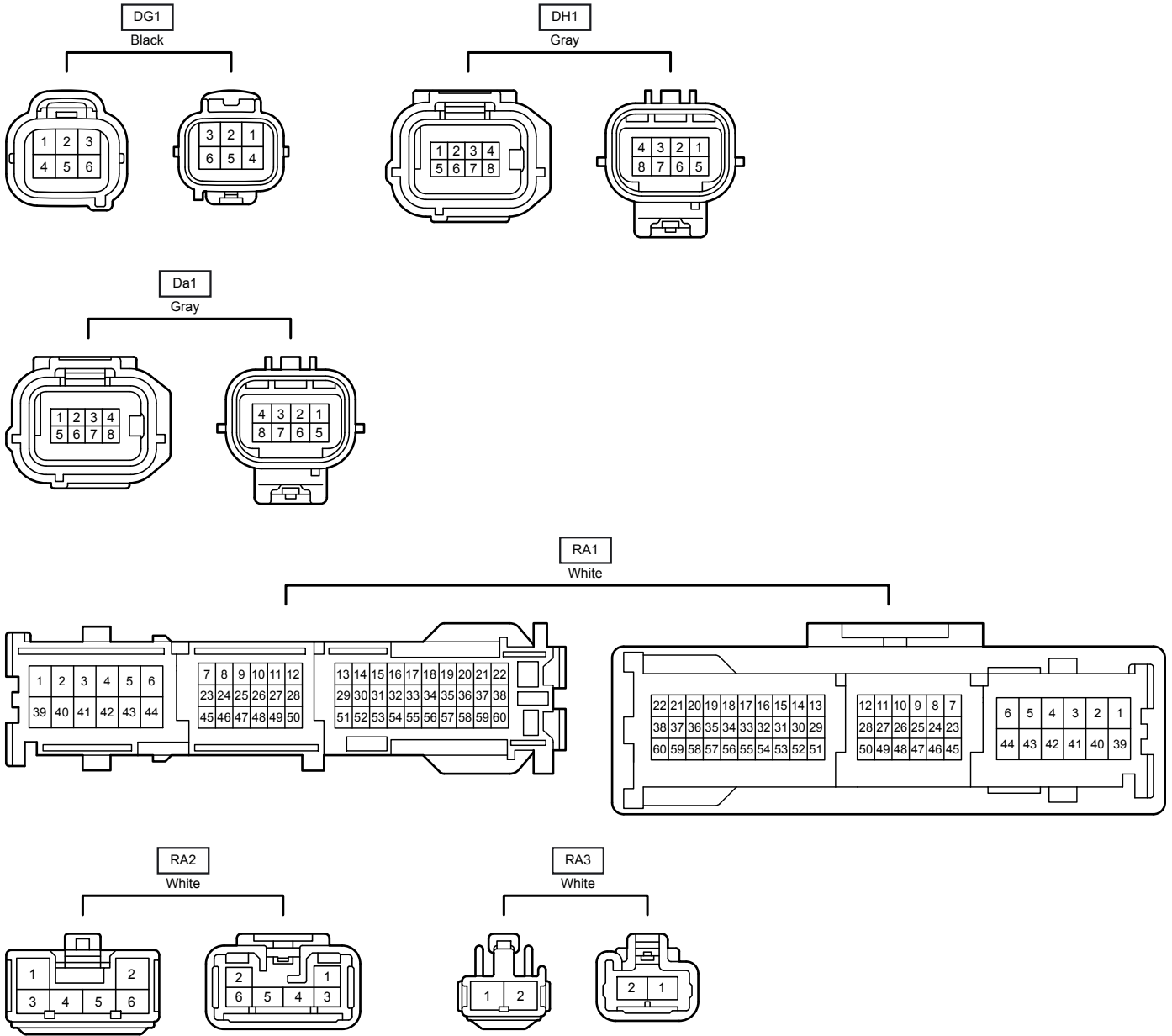

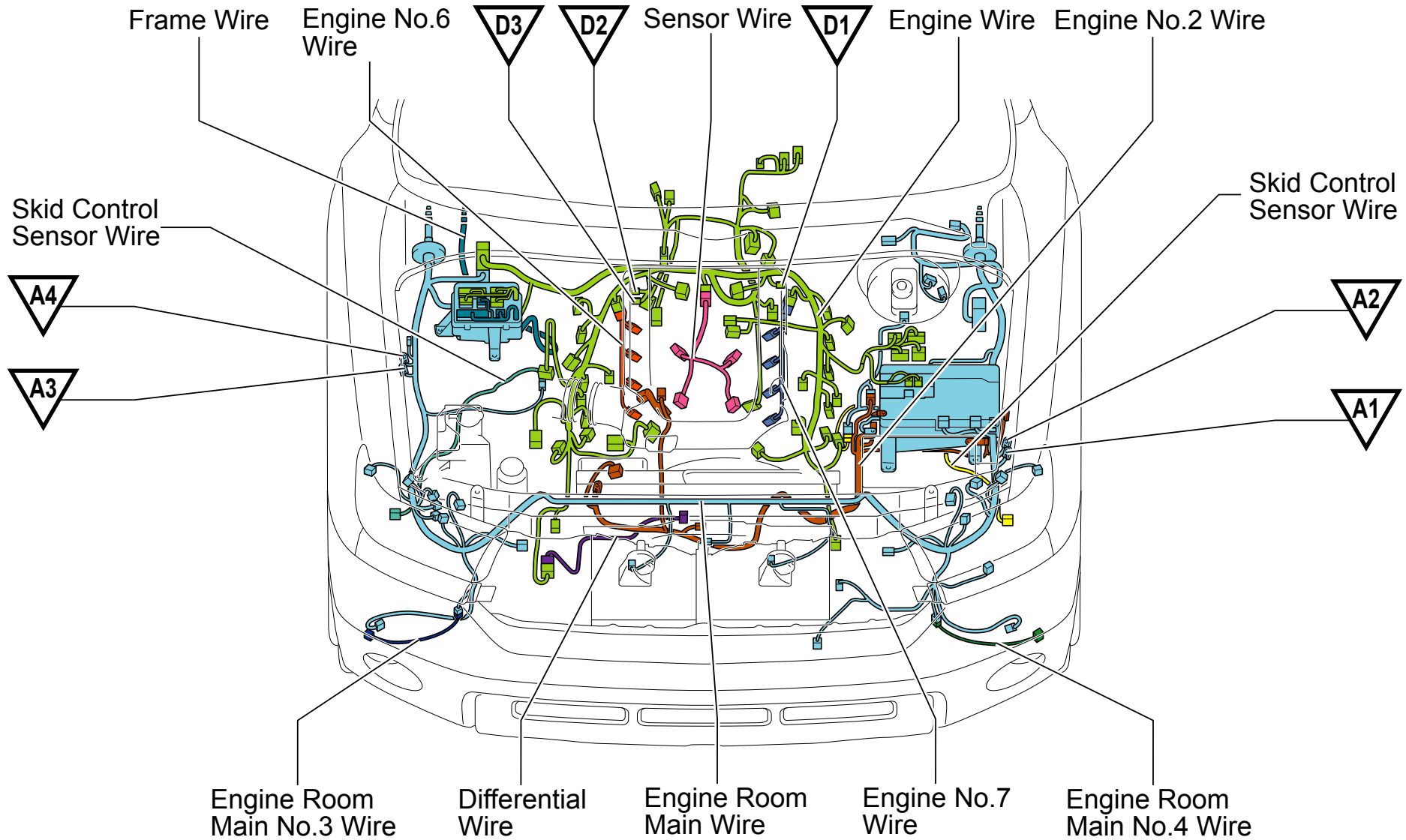

Position of Parts in Engine Compartment <3UR-FE, 3UR-FBE>

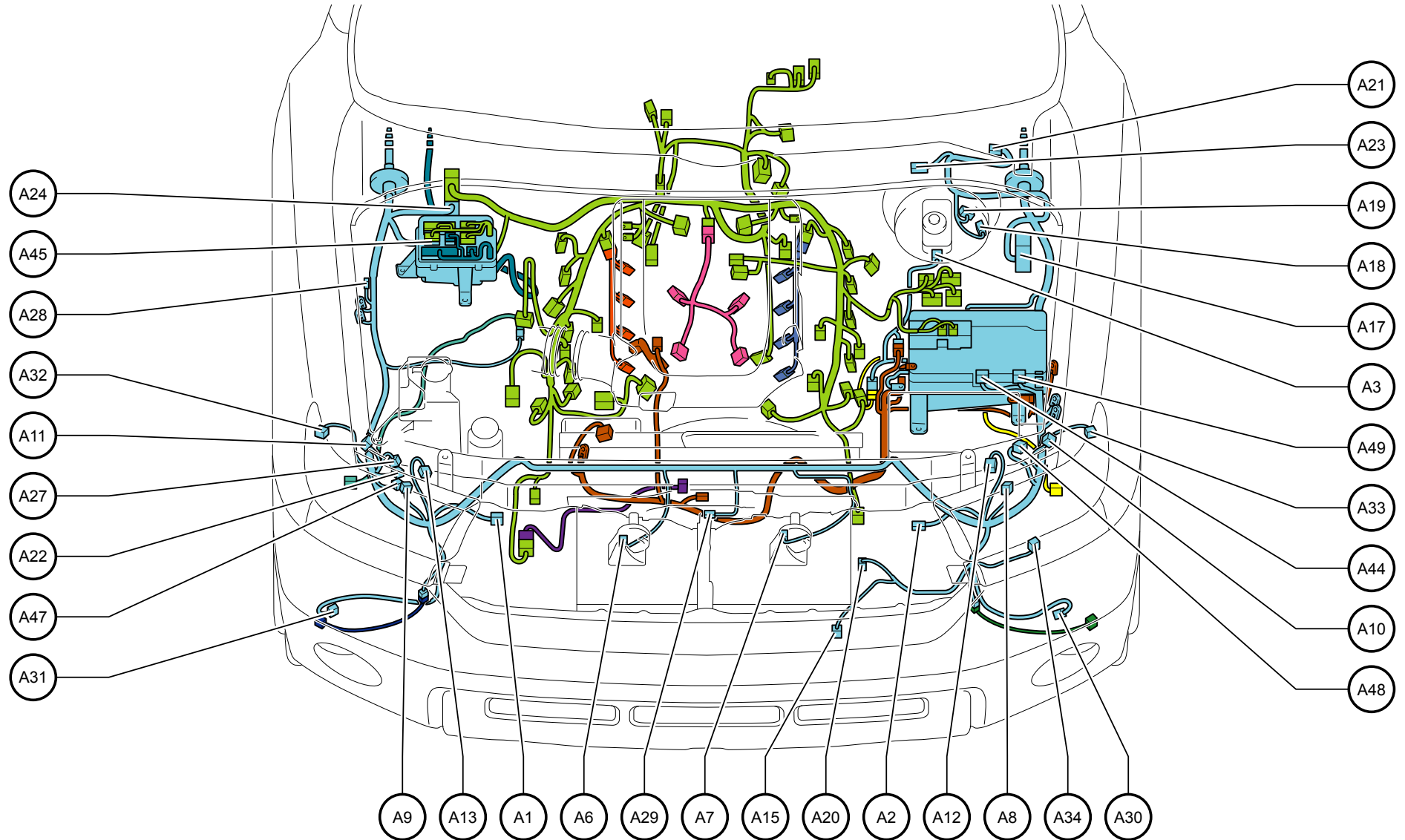

Position of Parts in Engine Compartment <3UR-FE, 3UR-FBE>

---

- A 1 Front Airbag Sensor RH
- A 2 Front Airbag Sensor LH
- A 3 Brake Fluid Level Warning Switch
- A 6 High Pitched Horn
- A 7 Low Pitched Horn
- A 8 Headlight LH (High)
- A 9 Headlight RH (High)
- A 10 Headlight LH (Low)
- A 11 Headlight RH (Low)
- A 12 Front Parking Light LH , Front Turn Signal Light LH
- A 13 Front Parking Light RH , Front Turn Signal Light RH
- A 15 Ambient Temperature Sensor
- A 17 Skid Control ECU with Actuator
- A 18 Active Brake Booster
- A 19 Pedal Stroke Speed Sensor
- A 20 A/C Pressure Switch
- A 21 Windshield Wiper Motor
- A 22 Washer Motor
- A 23 Front Wiper Deicer
- A 24 Engine Control Module
- A 27 Washer Fluid Level Sensor
- A 28 Security Horn
- A 29 Engine Hood Courtesy Switch
- A 30 Fog Light LH
- A 31 Fog Light RH
- A 32 Front Side Marker Light RH
- A 33 Front Side Marker Light LH
- A 34 Wireless Door Lock Buzzer
- A 44 Junction Connector
- A 45 Junction Connector
- A 47 Headlight Levering Motor RH
- A 48 Headlight Levering Motor LH
- A 49 Junction Connector

Position of Parts in Engine Compartment <3UR-FE, 3UR-FBE>

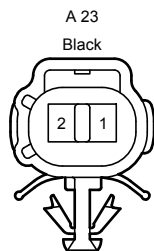
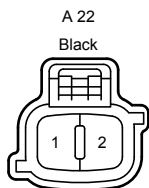
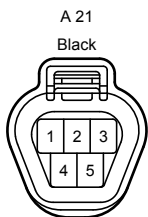
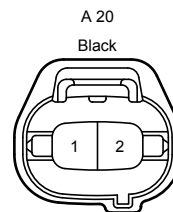
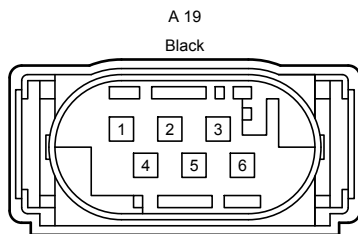
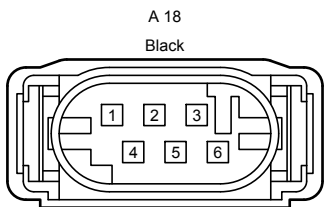
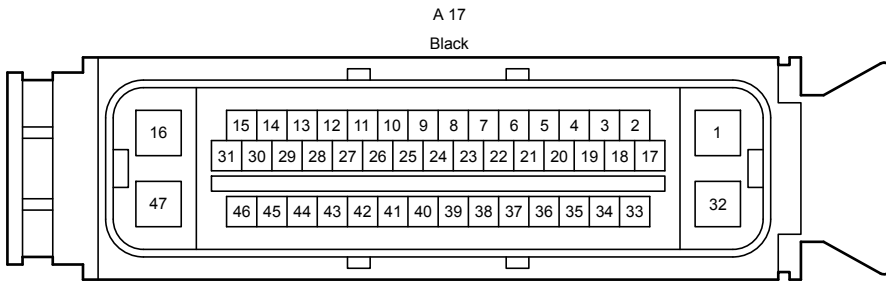
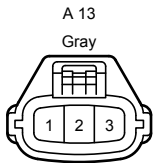
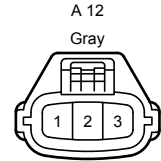
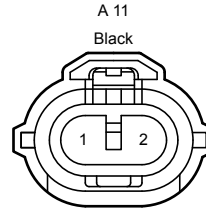
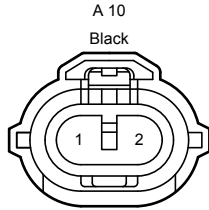
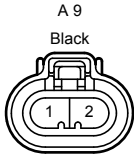
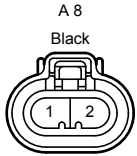
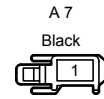
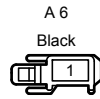
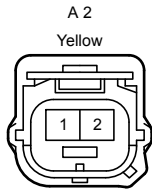
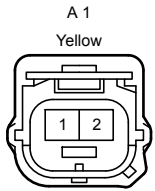

Position of Parts in Engine Compartment <3UR-FE, 3UR-FBE>

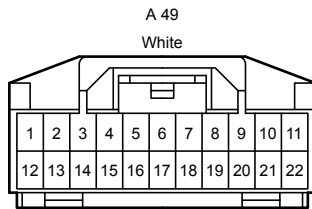
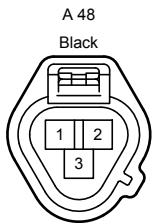
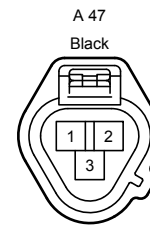
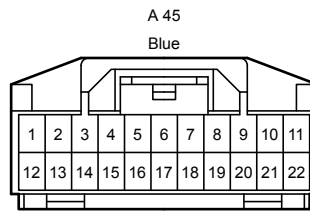
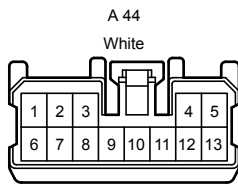
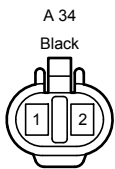
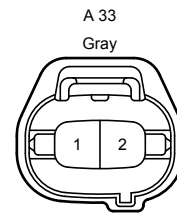
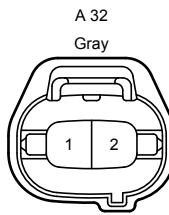
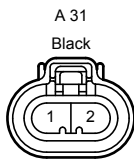
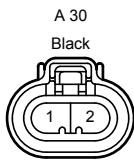
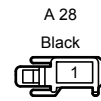
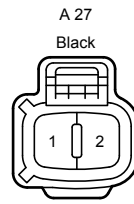
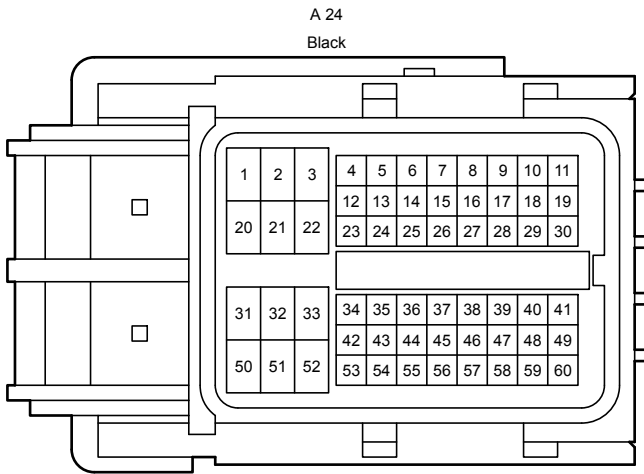



Position of Parts in Engine Compartment <3UR-FE, 3UR-FBE>

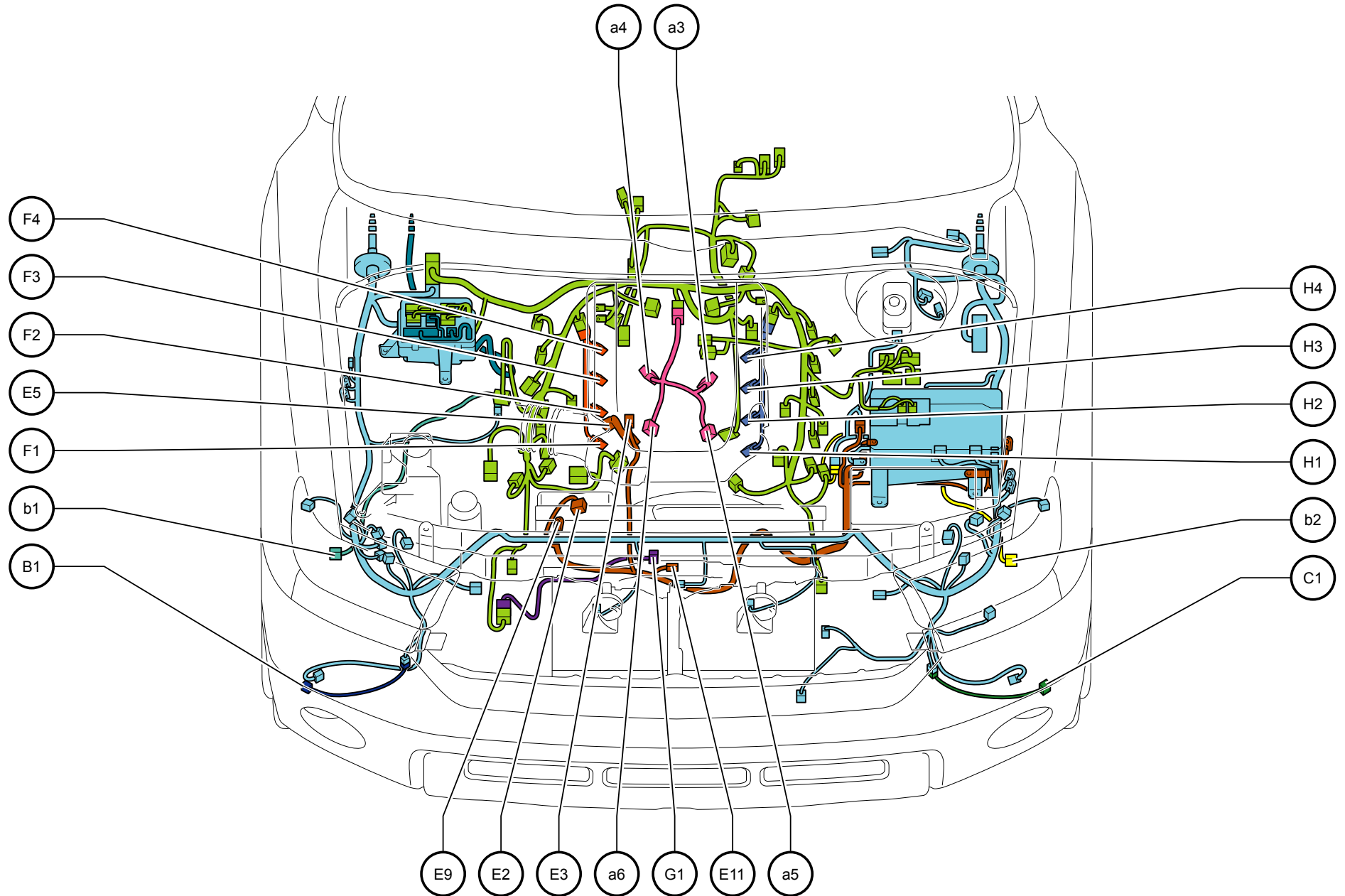

B 1 No.1 Ultrasonic Sensor (Front Right)

C 1 No.1 Ultrasonic Sensor (Front Left)

E 2 Generator

E 3 Starter

E 5 Starter

E 9 Generator

E 11 Oil Pressure Sender

F 1 Fuel Injector (No.2)

F 2 Fuel Injector (No.4)

F 3 Fuel Injector (No.6)

F 4 Fuel Injector (No.8)

G 1 ADD Actuator

H 1 Fuel Injector (No.1)

H 2 Fuel Injector (No.3)

H 3 Fuel Injector (No.5)

H 4 Fuel Injector (No.7)

a 3 Knock Sensor (Bank 1 Sensor 2)

a 4 Knock Sensor (Bank 2 Sensor 2)

a 5 Knock Sensor (Bank 1 Sensor 1)

a 6 Knock Sensor (Bank 2 Sensor 1)

b 1 Front Speed Sensor RH

b 2 Front Speed Sensor LH

Position of Parts in Engine Compartment <3UR-FE, 3UR-FBE>

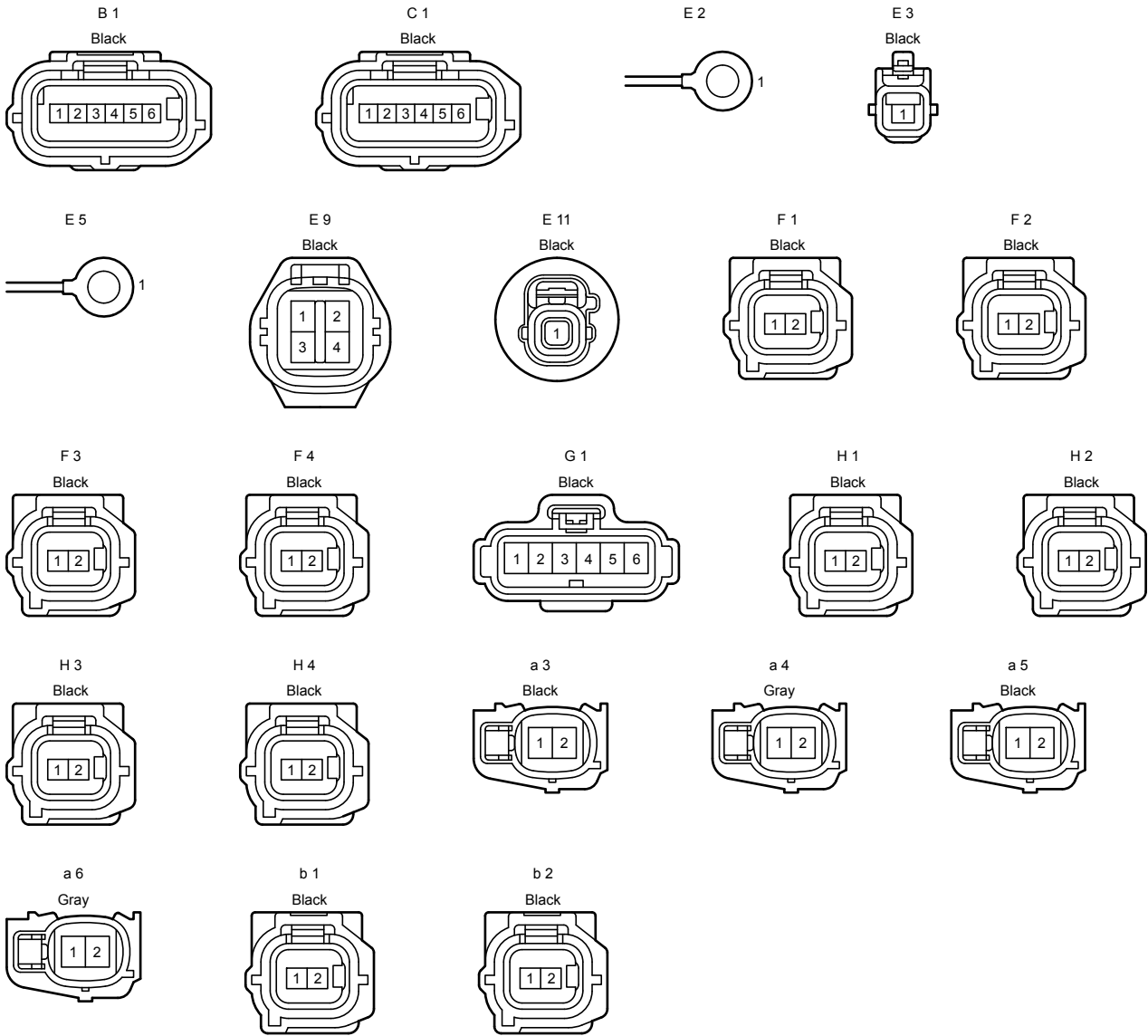

Position of Parts in Engine Compartment <3UR-FE, 3UR-FBE>

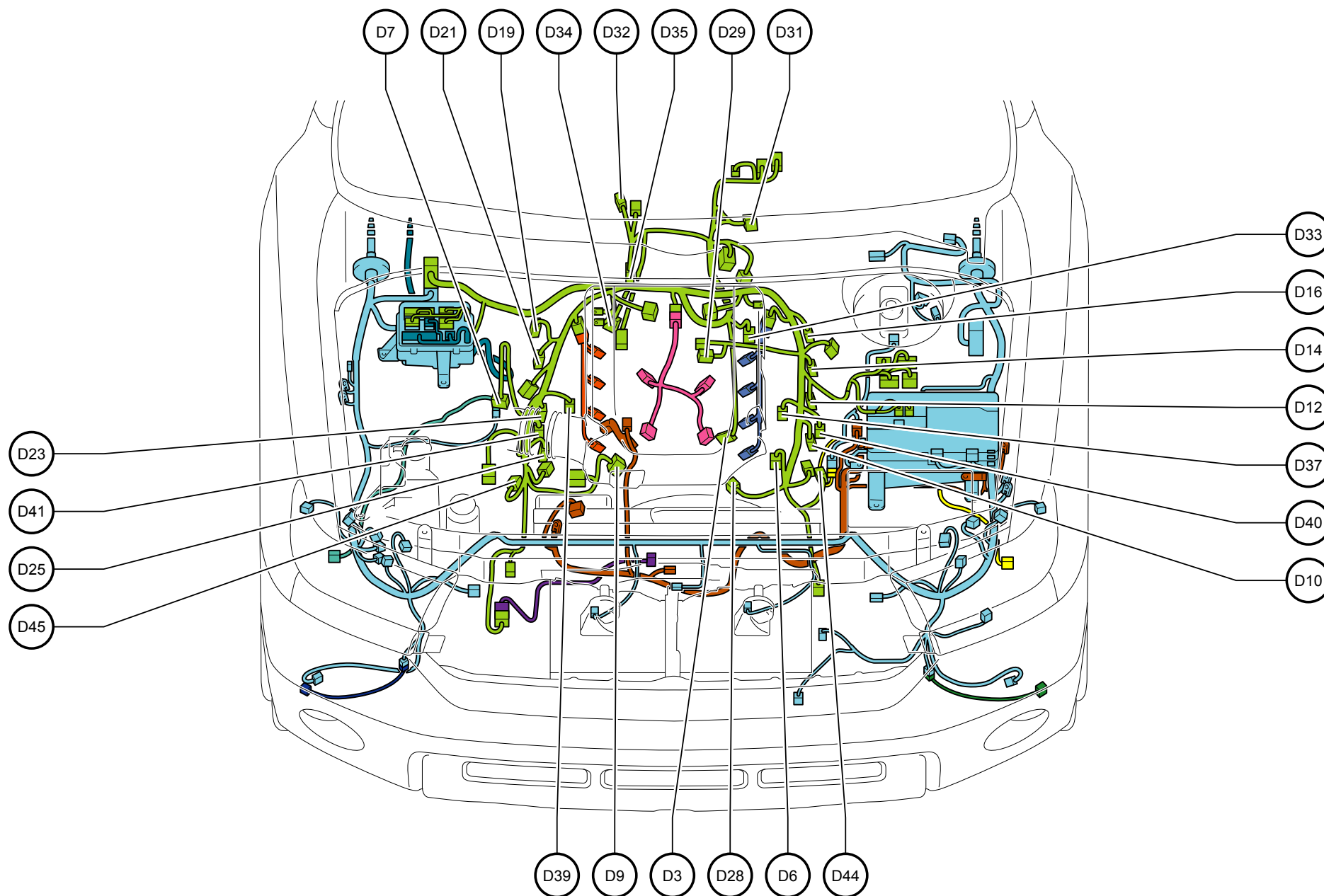

- D 3 Crankshaft Position Sensor
- D 6 Camshaft Position Sensor
- D 7 Mass Air Flow Meter
- D 9 Throttle Position Sensor
- D 10 Ignition Coil (No.1)
- D 12 Ignition Coil (No.3)
- D 14 Ignition Coil (No.5)
- D 16 Ignition Coil (No.7)
- D 19 Ignition Coil (No.8)
- D 21 Ignition Coil (No.6)
- D 23 Ignition Coil (No.4)
- D 25 Ignition Coil (No.2)
- D 28 Engine Coolant Temperature Sensor
- D 29 Purge VSV
- D 31 Heated Oxygen Sensor (Bank 1 Sensor 2)
- D 32 Heated Oxygen Sensor (Bank 2 Sensor 2)
- D 33 Air Fuel Ratio Sensor (Bank 1 Sensor 1)
- D 34 Air Fuel Ratio Sensor (Bank 2 Sensor 1)
- D 35 Park/Neutral Position Switch
- D 37 VVT Sensor (Bank 1 Intake Side)
- D 39 VVT Sensor (Bank 2 Intake Side)
- D 40 VVT Sensor (Bank 1 Exhaust Side)
- D 41 VVT Sensor (Bank 2 Exhaust Side)
- D 44 Camshaft Timing Oil Control Valve (Bank 1 Exhaust Side)
- D 45 Camshaft Timing Oil Control Valve (Bank 2 Exhaust Side)

Position of Parts in Engine Compartment <3UR-FE, 3UR-FBE>

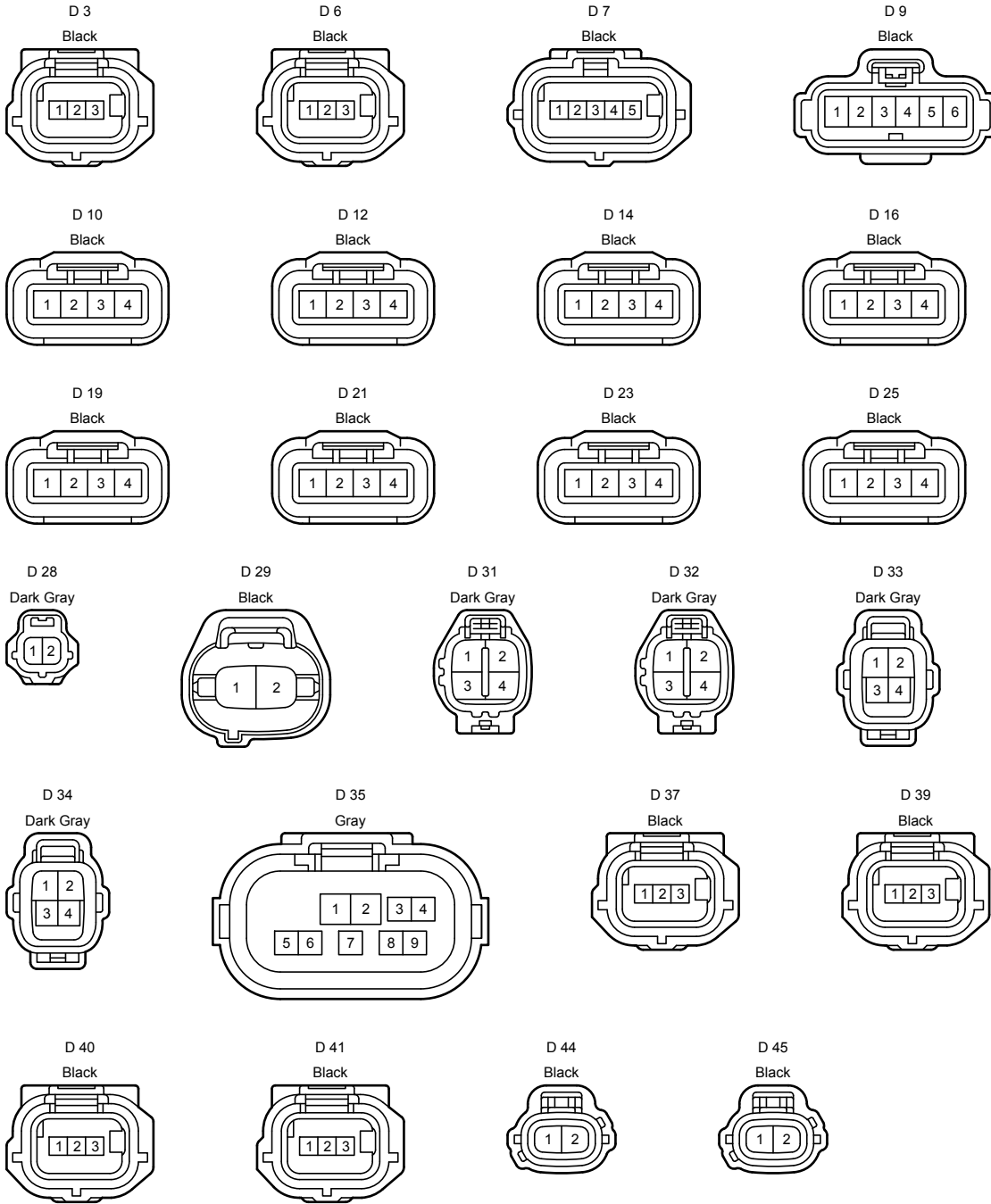

Position of Parts in Engine Compartment <3UR-FE, 3UR-FBE>

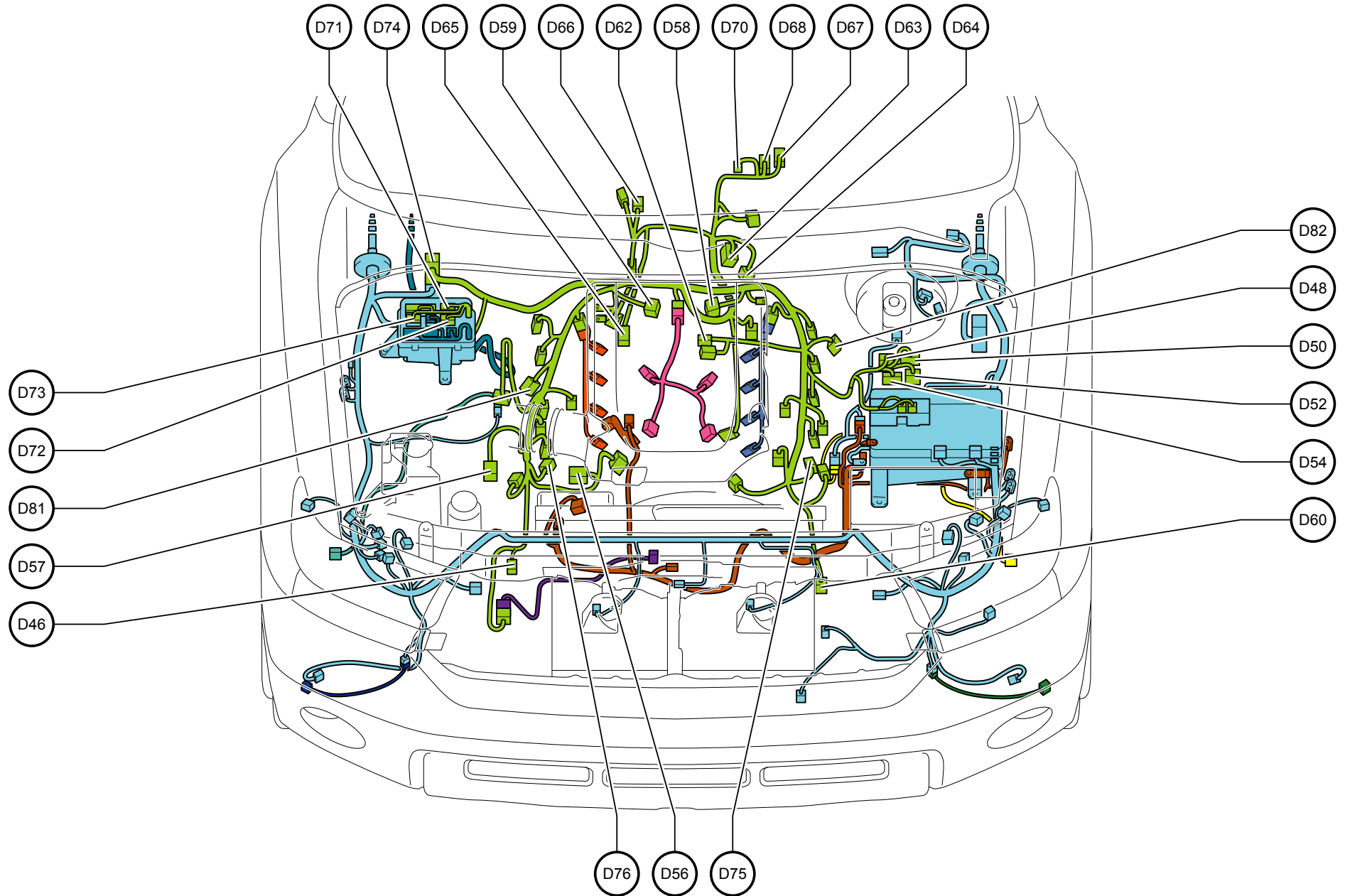

- D 46 Power Steering Oil Pressure Sensor
- D 48 Air Injection Control Driver (Bank 1)
- D 50 Air Injection Control Driver (Bank 1)
- D 52 Air Injection Control Driver (Bank 2)
- D 54 Air Injection Control Driver (Bank 2)
- D 56 Air Pump (Bank 1)
- D 57 Air Pump (Bank 2)
- D 58 Air Switching Valve (Bank 1)
- D 59 Air Switching Valve (Bank 2)
- D 60 A/C Compressor
- D 62 ACIS VSV
- D 63 Automatic Transmission
- D 64 Automatic Transmission
- D 65 Transmission Revolution Sensor (Turbine)
- D 66 Transmission Revolution Sensor (Electronically Controlled Transmission)
- D 67 Transfer Shift Actuator
- D 68 Transfer Shift Actuator
- D 70 Transfer Shift Actuator
- D 71 Junction Connector
- D 72 Junction Connector
- D 73 Junction Connector
- D 74 Engine Control Module
- D 75 Camshaft Timing Oil Control Valve (Bank 1 Intake side)
- D 76 Camshaft Timing Oil Control Valve (Bank 2 Intake Side)
- D 81 Noise Filter (Ignition Bank 2)
- D 82 Noise Filter (Ignition Bank 1)



Position of Parts in Engine Compartment <3UR-FE, 3UR-FBE>

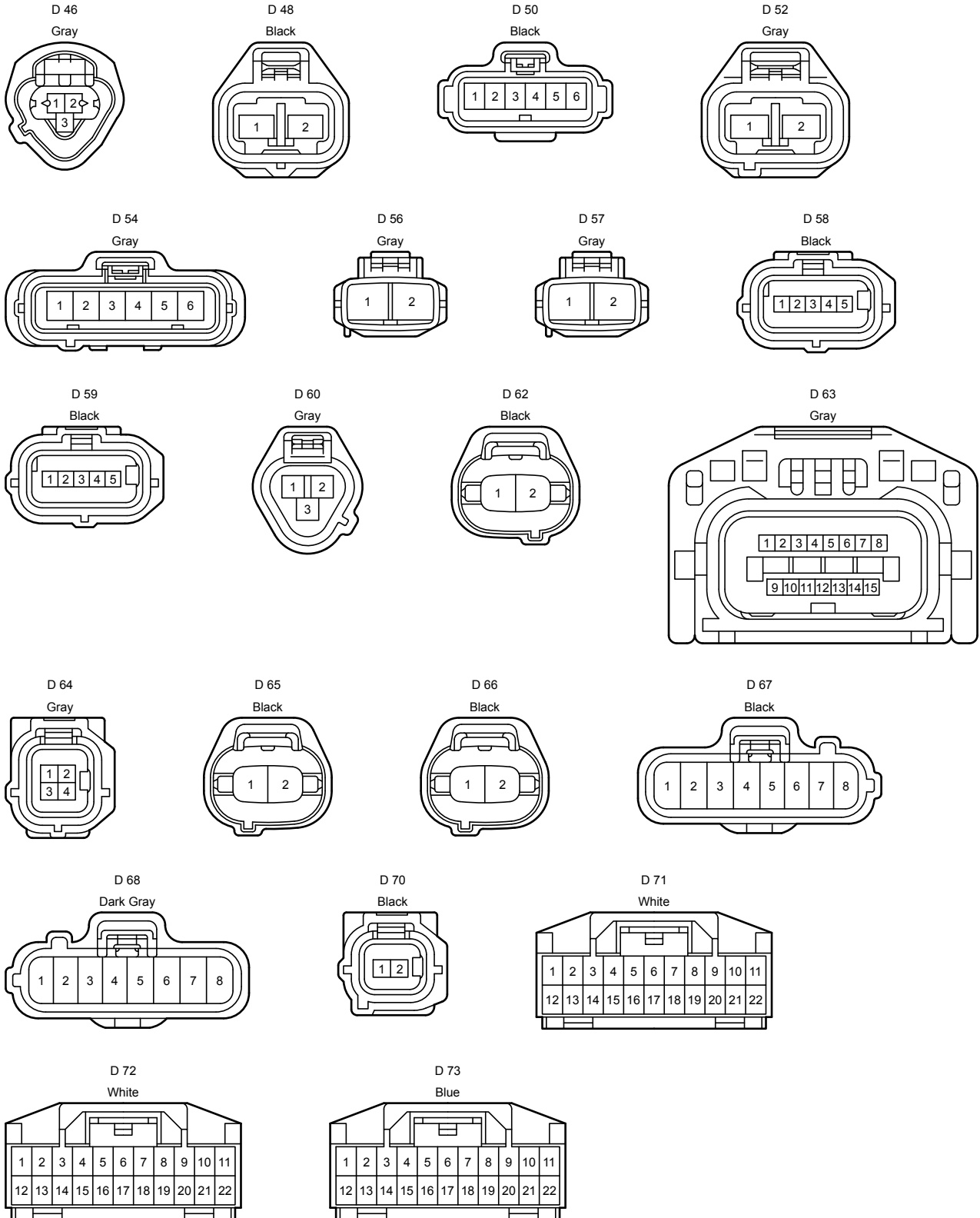

Position of Parts in Engine Compartment <3UR-FE, 3UR-FBE>

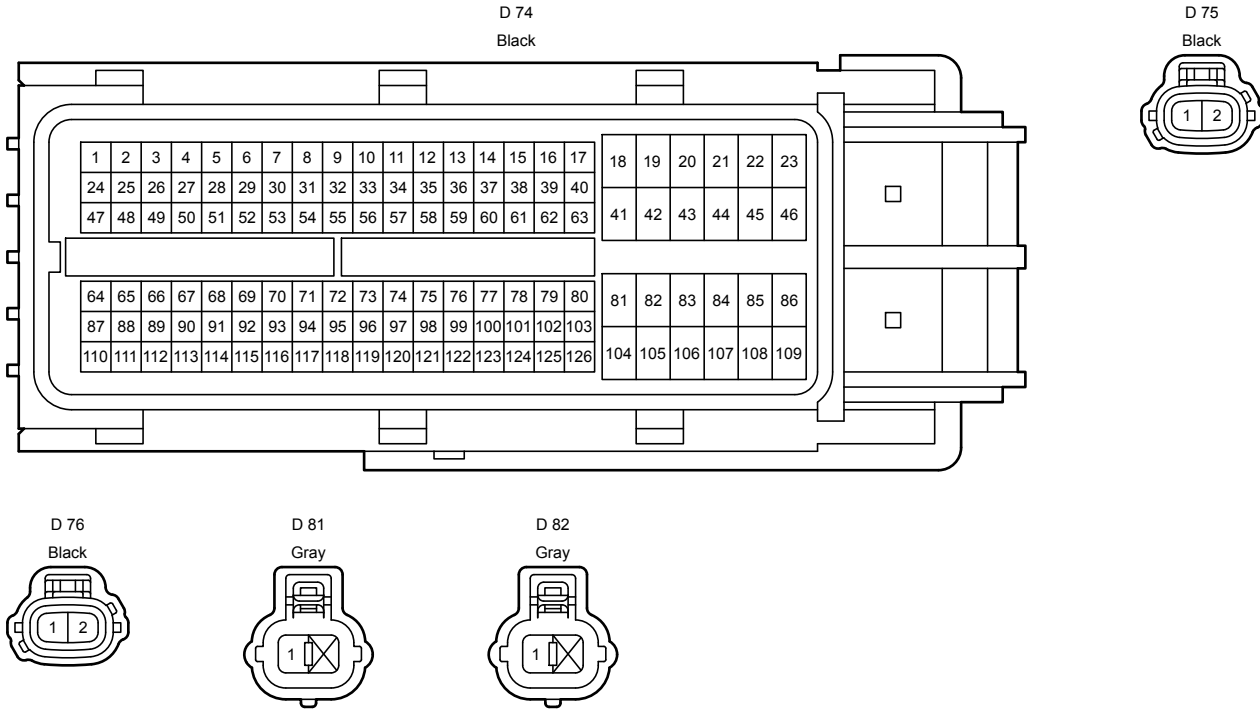

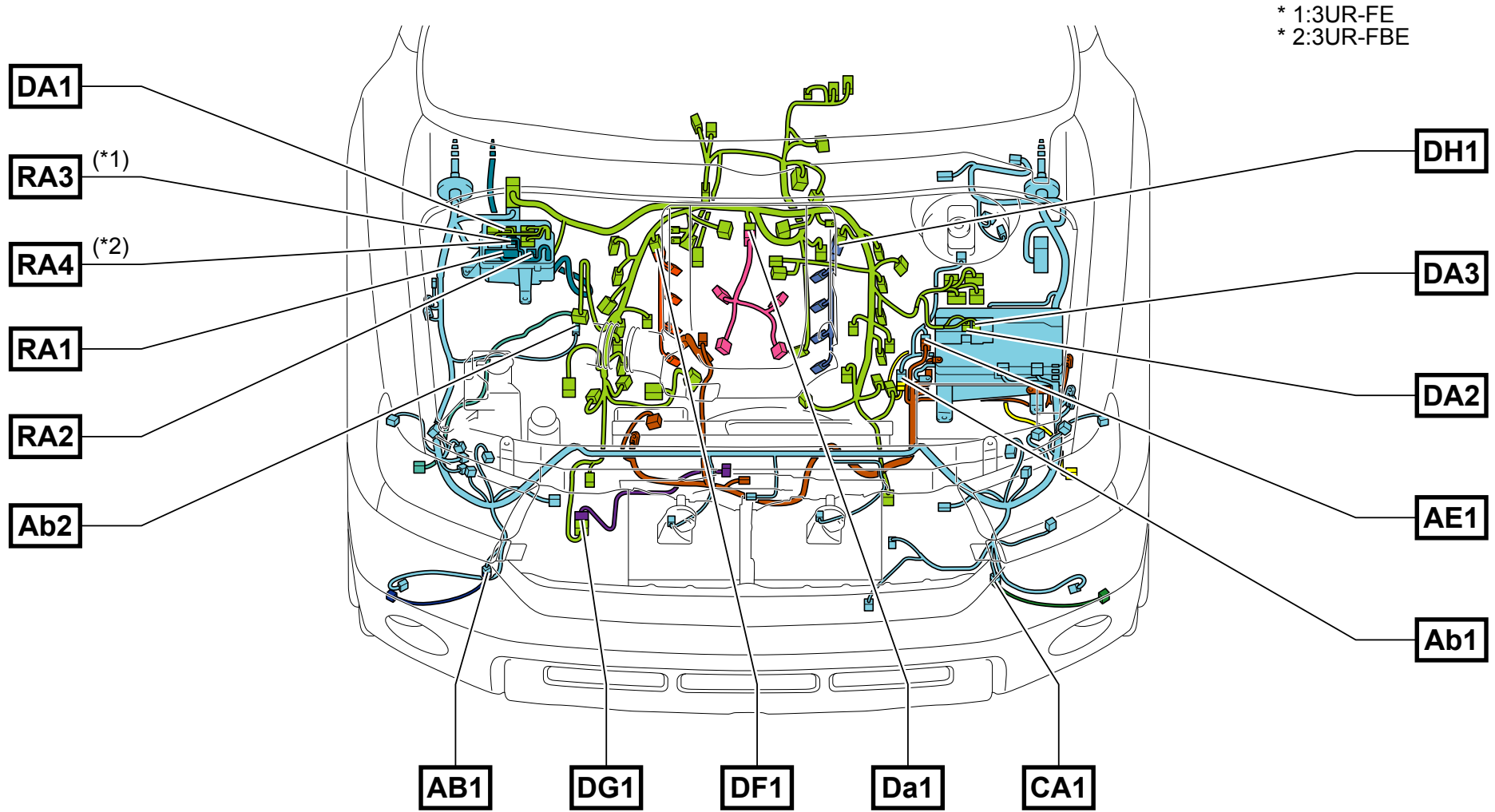

Wire and Wire in Engine Compartment <3UR-FE, 3UR-FBE>

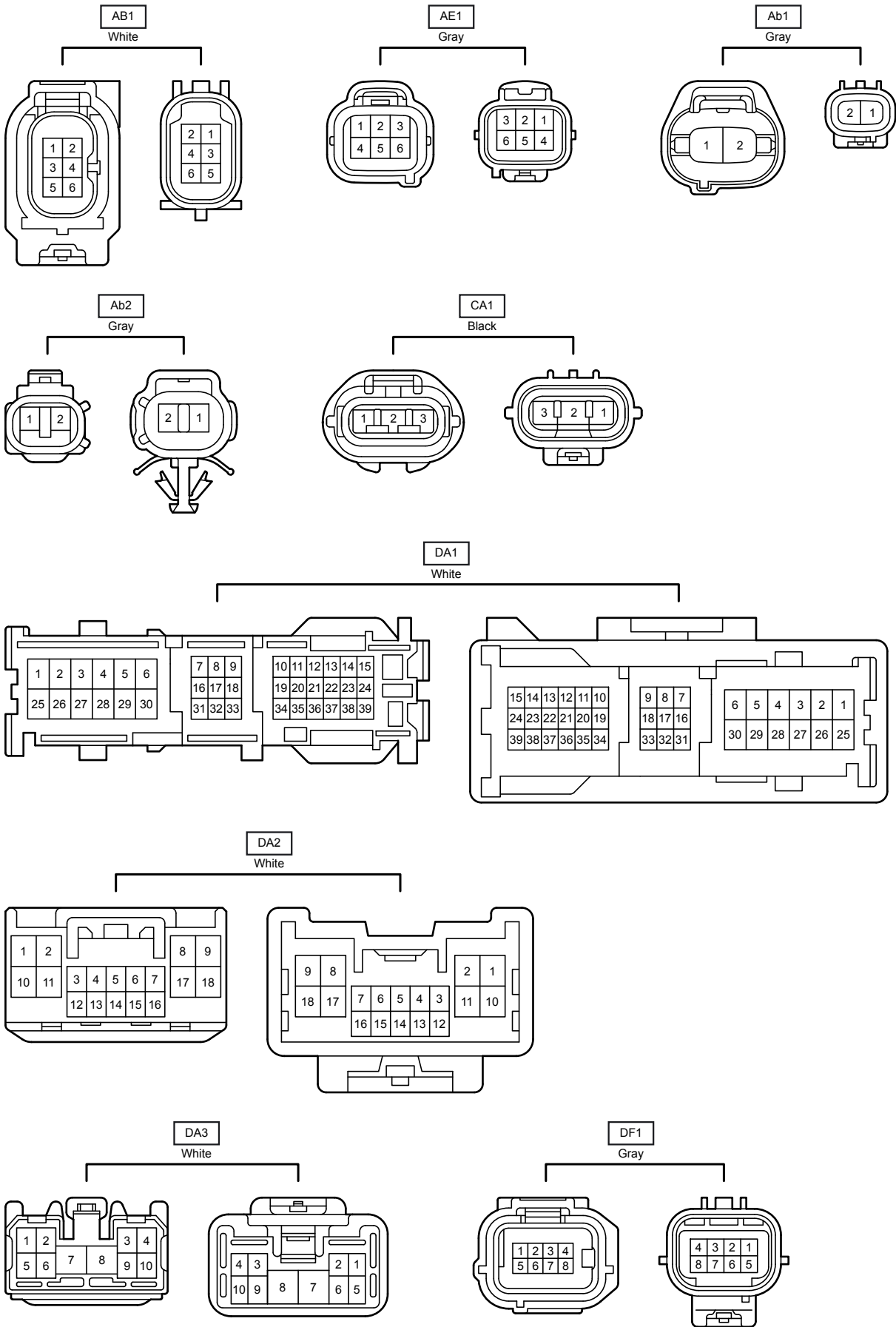

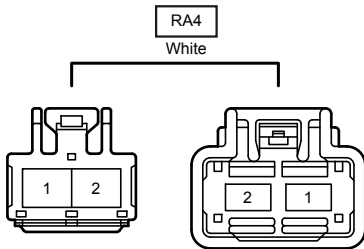
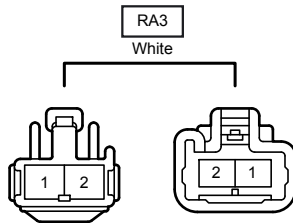
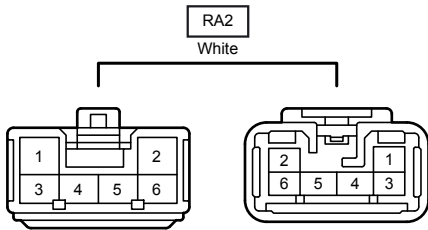
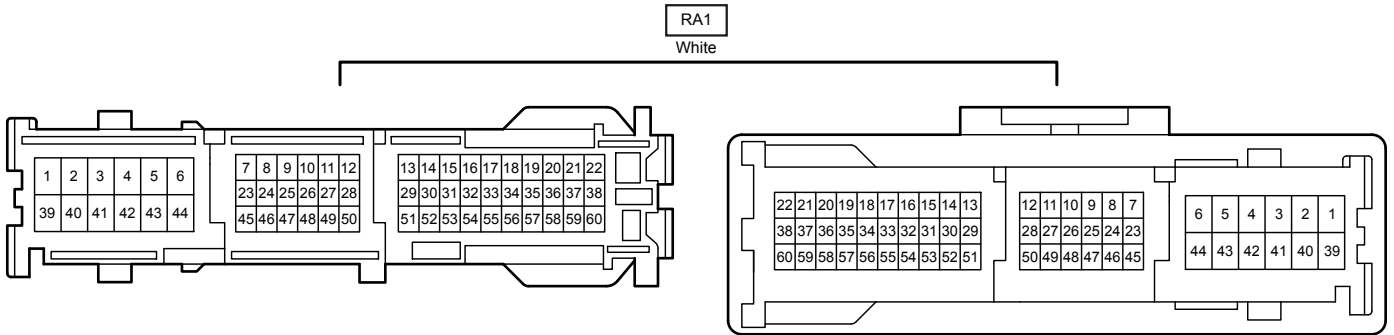
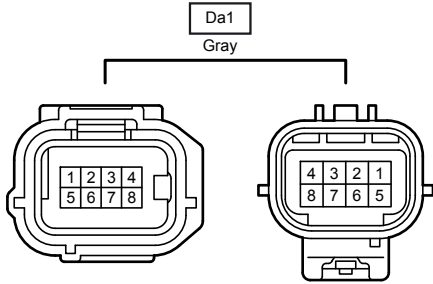
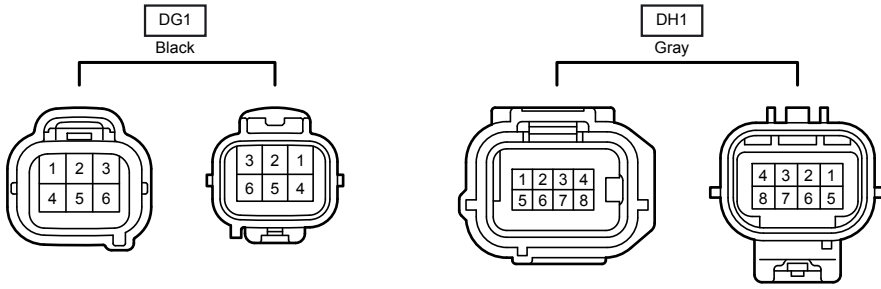

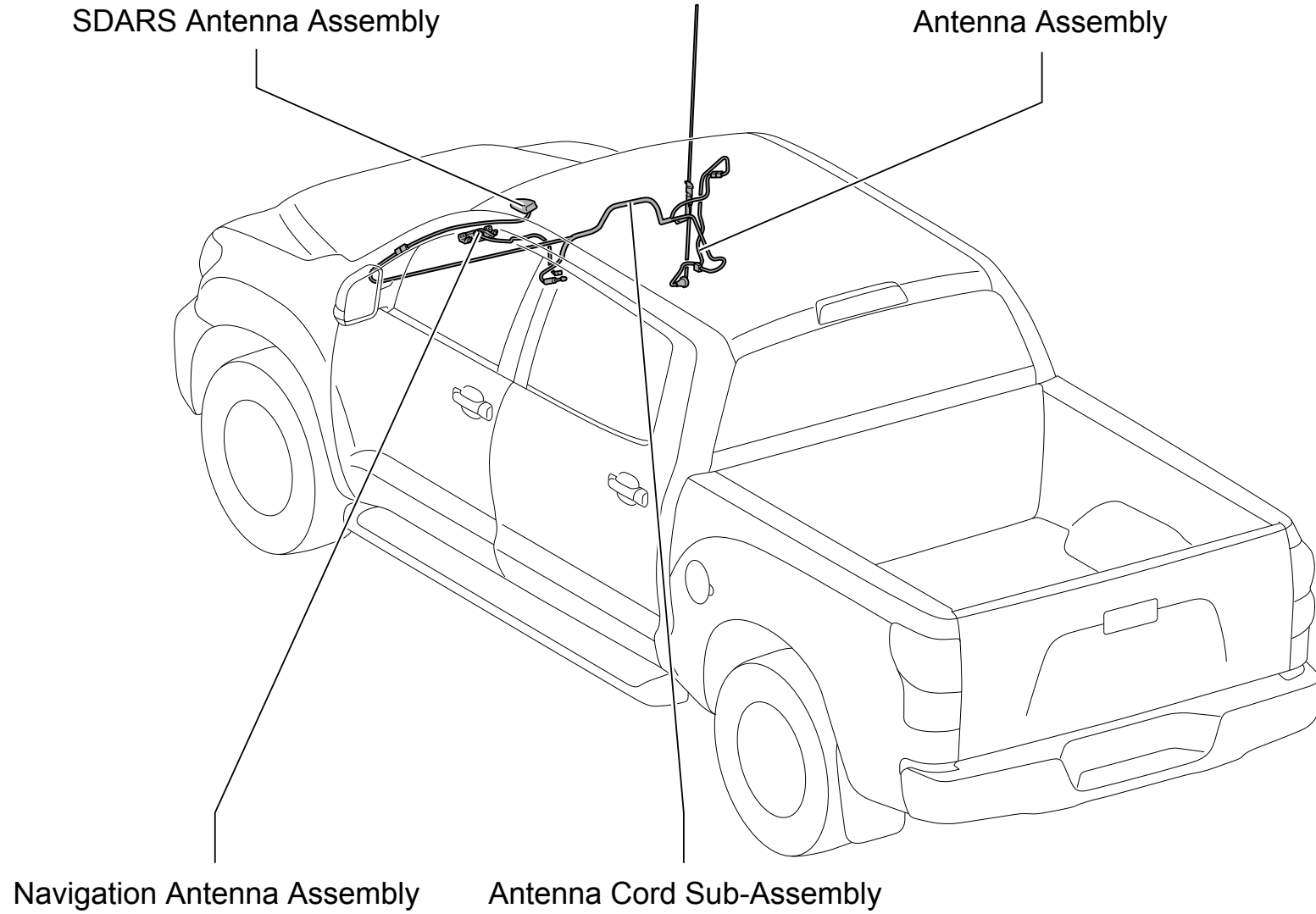

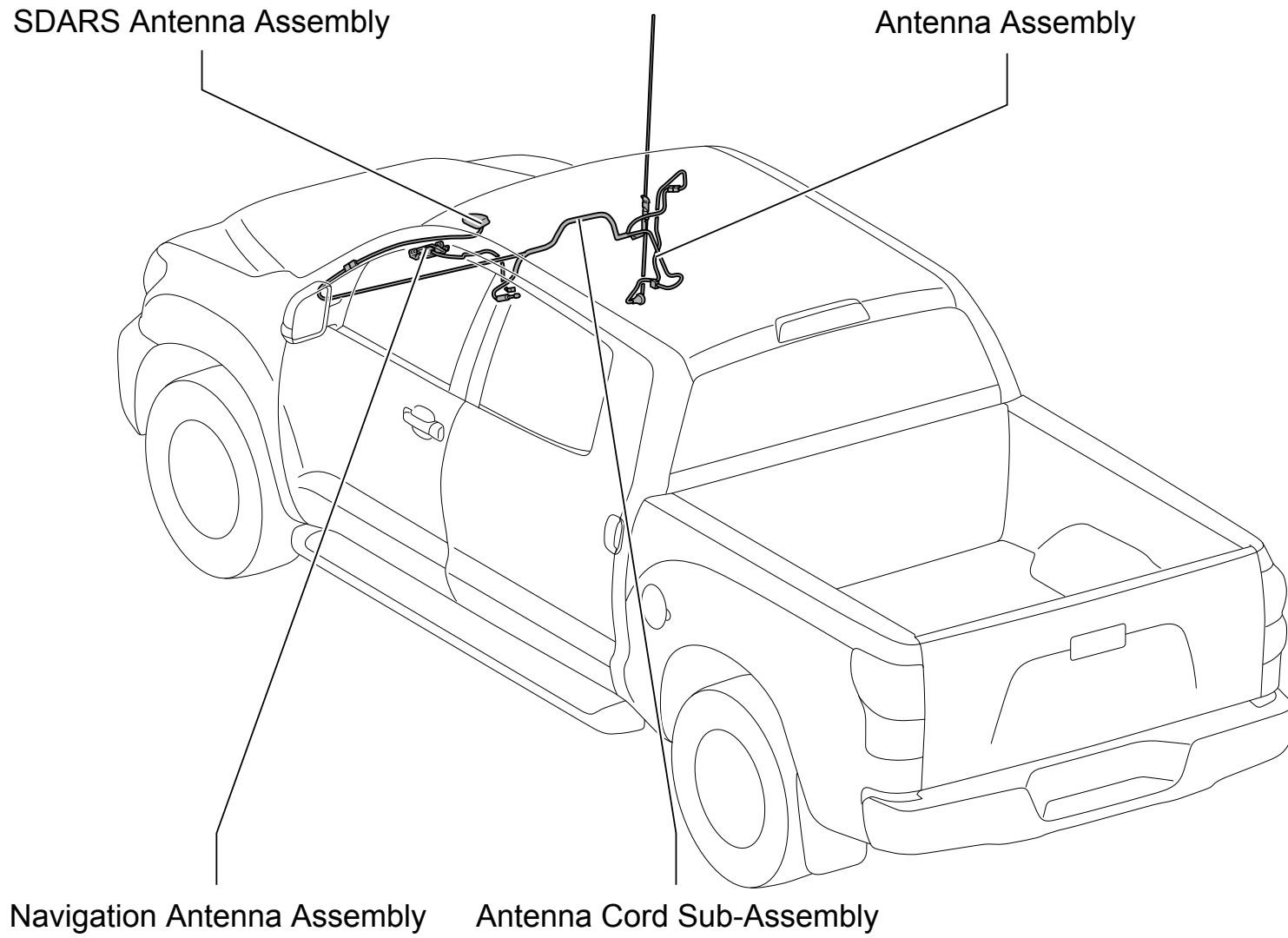

Position of Parts in Seat <Bench Seat>

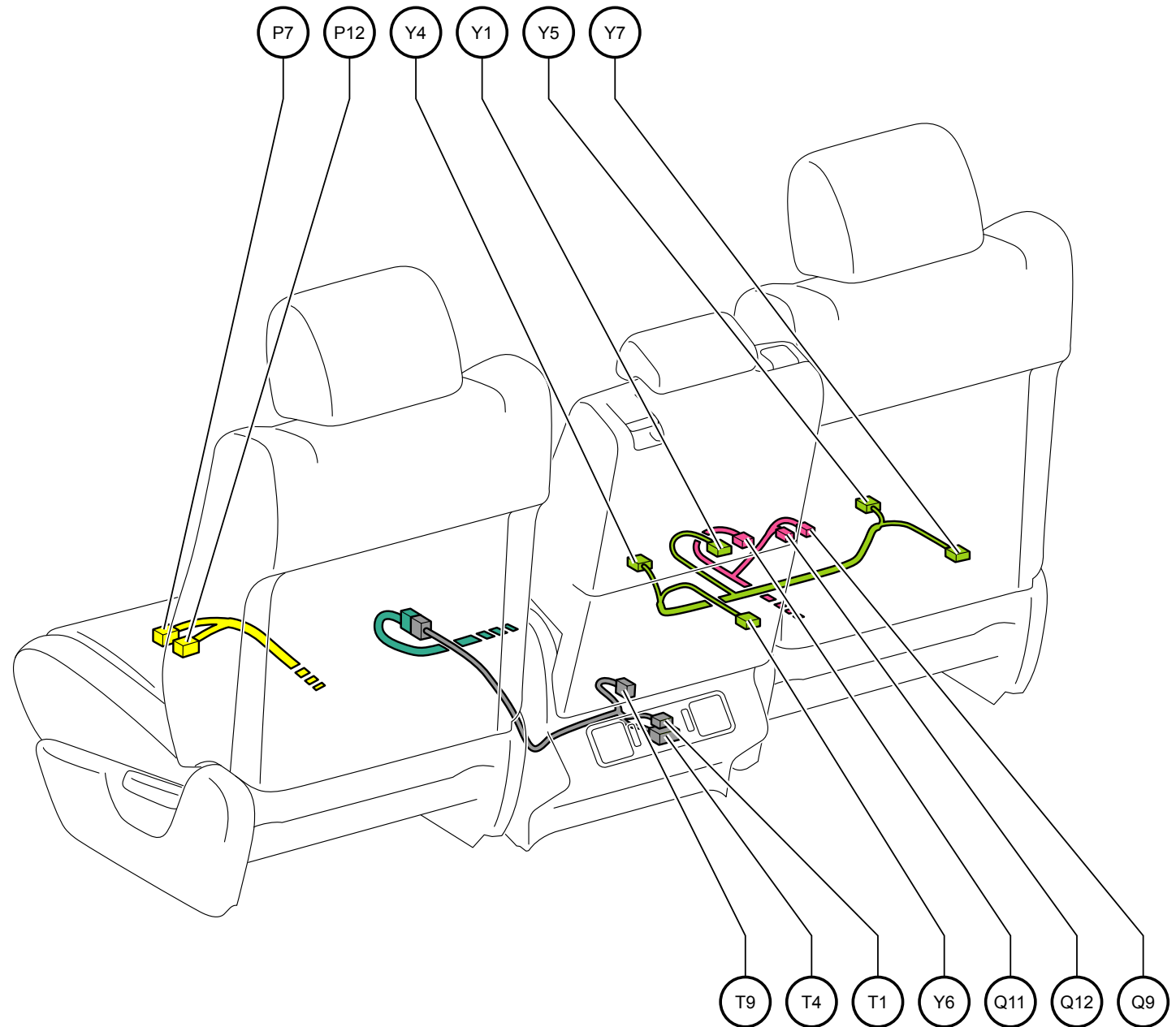



**Position of Parts in Seat <Bench Seat>**

---

P 7 Front Seat Inner Belt Switch LH  
P 12 Front Side Airbag Squib Circuit LH

Q 9 Front Side Airbag Squib Circuit RH  
Q 11 Occupant Detection ECU  
Q 12 Front Seat Inner Belt Switch RH

T 1 Power Outlet Socket (115V)  
T 4 Video Terminal  
T 9 Power Outlet Socket (No.3)

Y 1 Occupant Detection ECU  
Y 4 Front Occupant Classification Sensor LH  
Y 5 Front Occupant Classification Sensor RH  
Y 6 Rear Occupant Classification Sensor LH  
Y 7 Rear Occupant Classification Sensor RH

Position of Parts in Seat <Bench Seat>

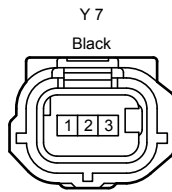
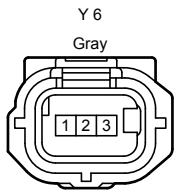
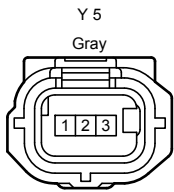
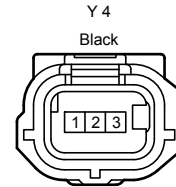
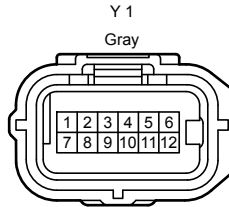
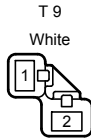
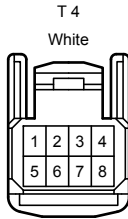
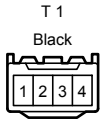
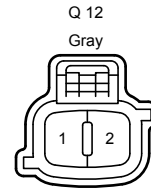
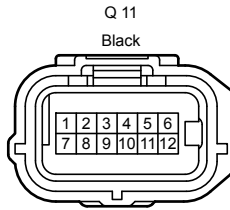
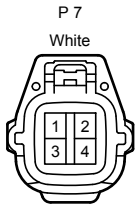

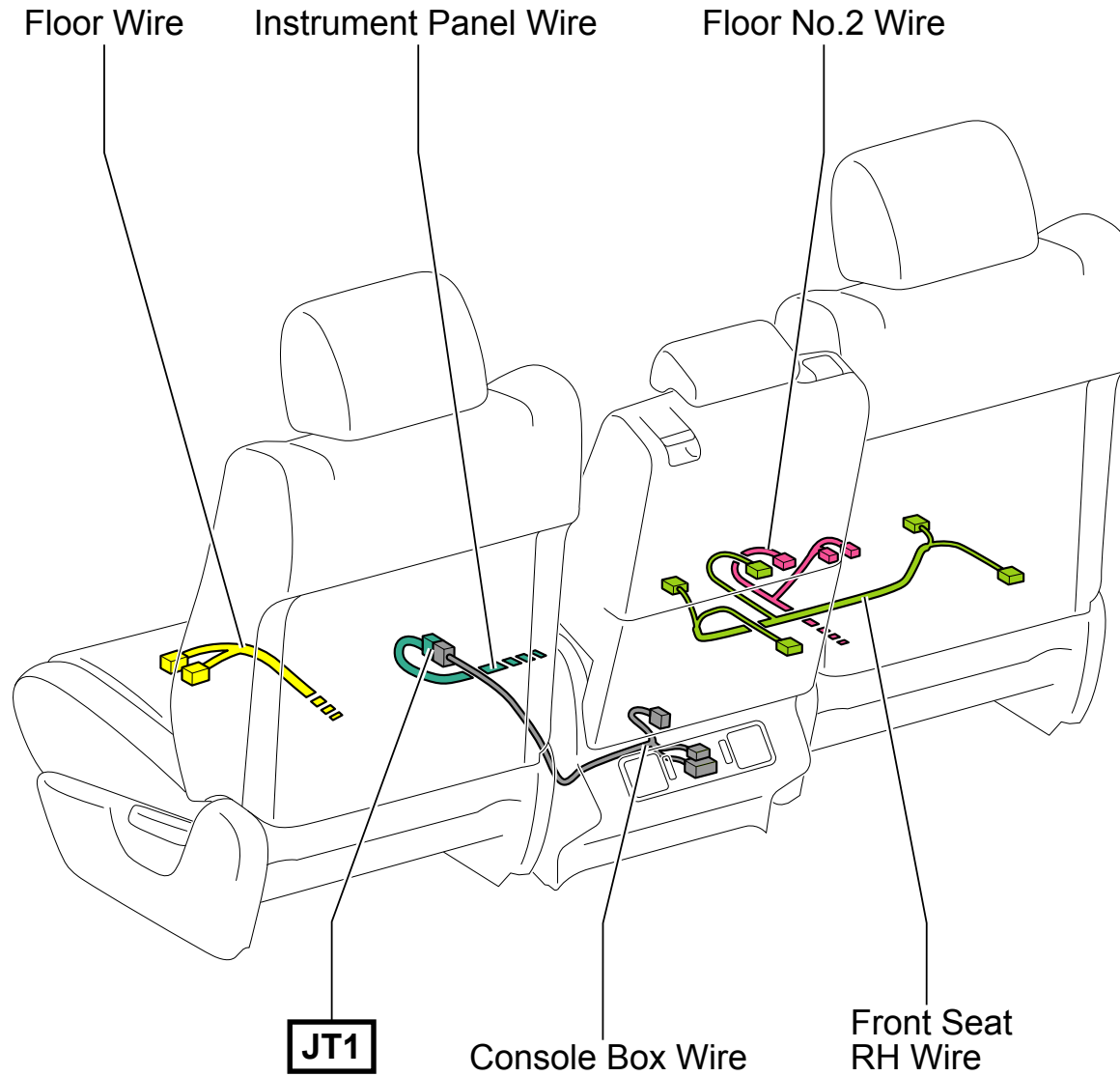

Wire and Wire , Ground Points in Seat <Bench Seat>

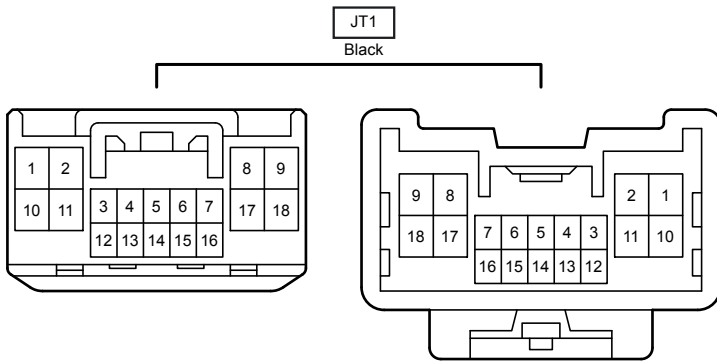

Position of Parts in Body <CrewMax>

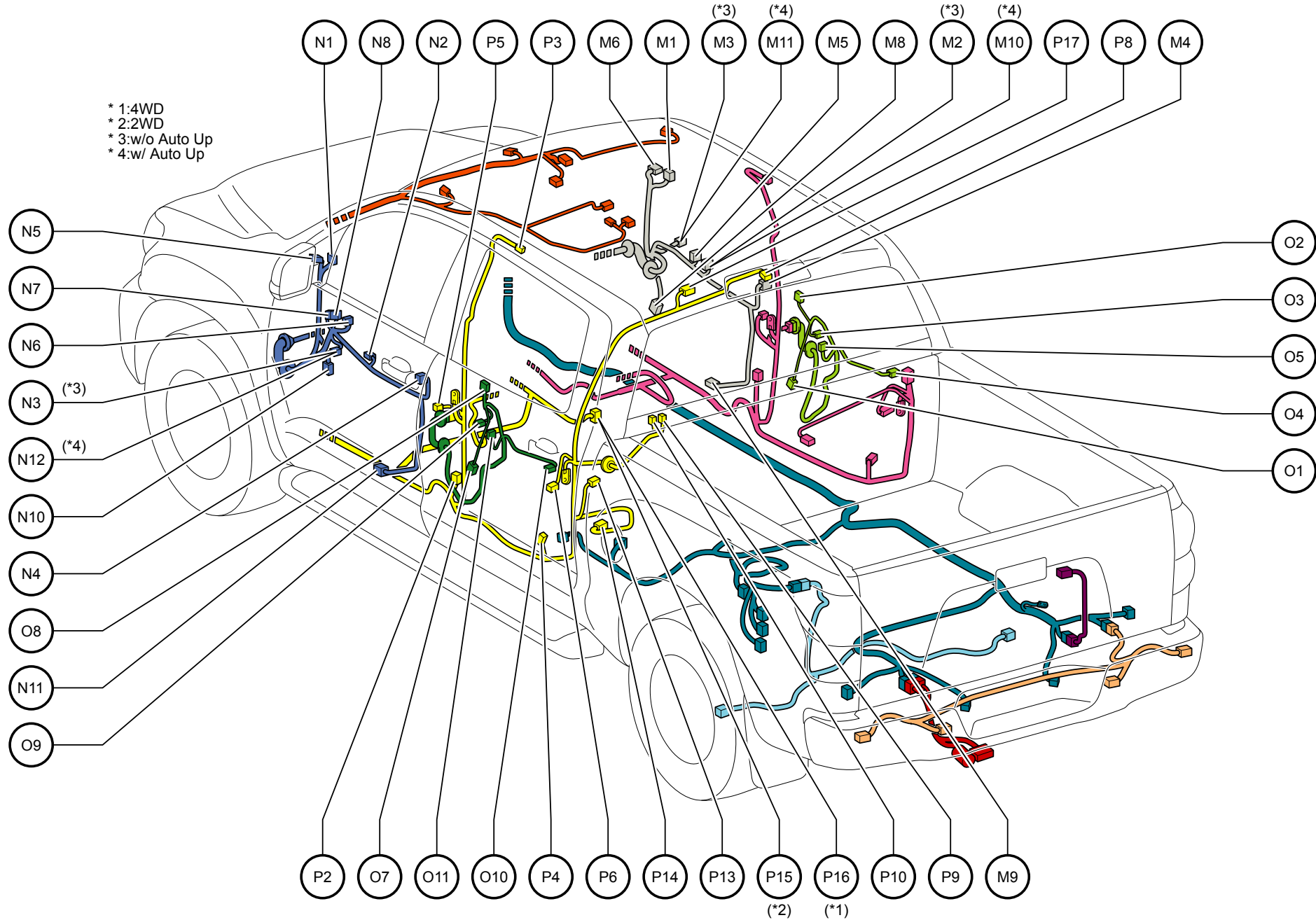

Position of Parts in Body <CrewMax>

---

- M 1 Front Door Tweeter RH
- M 2 Front Power Window Switch RH
- M 3 Front Power Window Regulator Motor RH
- M 4 Front Door Lock Motor RH
- M 5 Front Door Lock Switch RH
- M 6 Outer Rear View Mirror RH
- M 8 Front Door Speaker RH
- M 9 Door Side Airbag Sensor RH
- M 10 Front Power Window Switch RH
- M 11 Front Power Window Regulator Motor RH
  
- N 1 Front Door Tweeter LH
- N 2 Power Window Regulator Master Switch
- N 3 Front Power Window Regulator Motor LH
- N 4 Front Door Lock Motor LH
- N 5 Outer Rear View Mirror LH
- N 6 Seat Memory Switch
- N 7 Outer Mirror Control ECU
- N 8 Outer Mirror Control ECU
- N 10 Front Door Speaker LH
- N 11 Door Side Airbag Sensor LH
- N 12 Front Power Window Regulator Motor LH
  
- O 1 Rear Door Speaker RH
- O 2 Tweeter (Rear RH)
- O 3 Rear Power Window Regulator Motor RH
- O 4 Rear Door Lock Motor RH
- O 5 Rear Power Window Switch RH
- O 7 Rear Door Speaker LH
- O 8 Tweeter (Rear LH)
- O 9 Rear Power Window Regulator Motor LH
- O 10 Rear Door Lock Motor LH
- O 11 Rear Power Window Switch LH
  
- P 2 Front Pretensioner LH
- P 3 Curtain Shield Airbag Squib Circuit LH
- P 4 Side Airbag Sensor LH
- P 5 Front Door Courtesy Switch LH
- P 6 Rear Door Courtesy Switch LH
- P 8 Cargo Light , High Mounted Stop Light
- P 9 Rear Window Defogger
- P 10 Rear Window Defogger
- P 13 Voltage Inverter
- P 14 Woofer
- P 15 Yaw Rate Sensor
- P 16 Yaw Rate Sensor
- P 17 Tire Pressure Warning Antenna and Receiver

Position of Parts in Body <CrewMax>

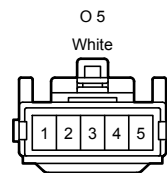
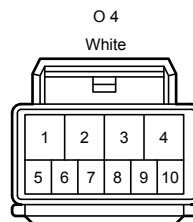
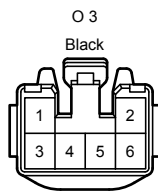
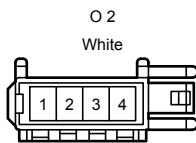
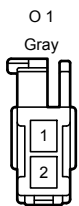
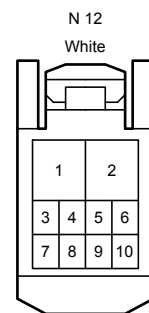
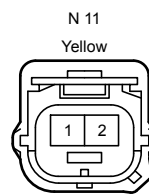
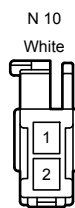
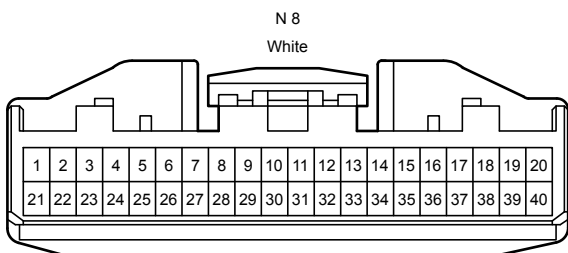
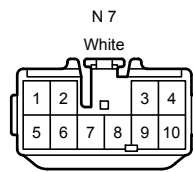
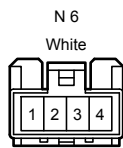
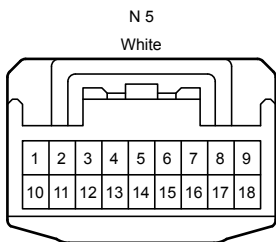
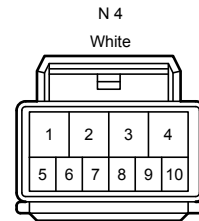
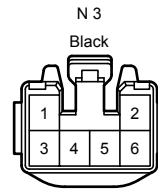
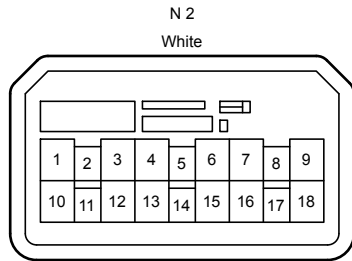
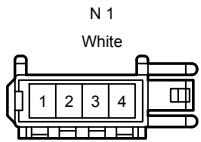
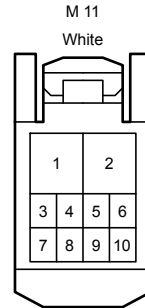
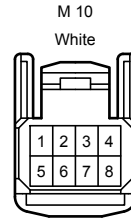
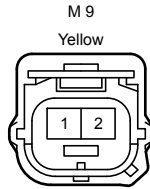
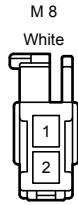
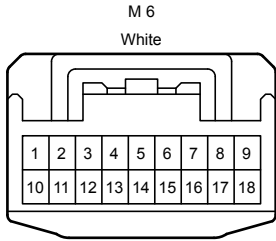
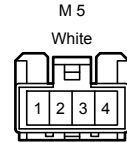
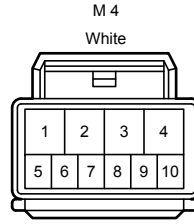
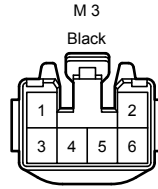
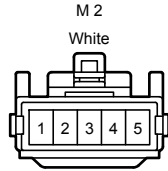
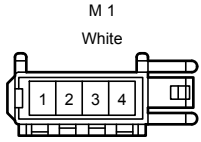

Position of Parts in Body <CrewMax>

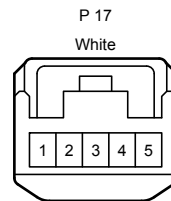
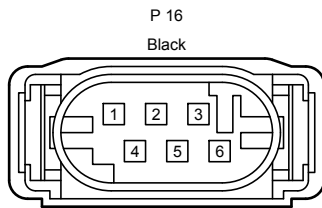
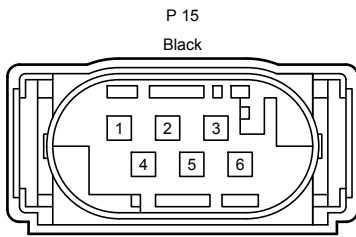
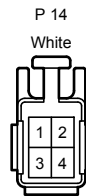
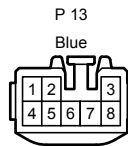
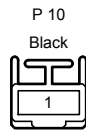
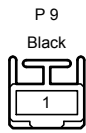
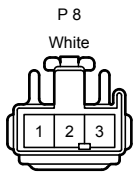
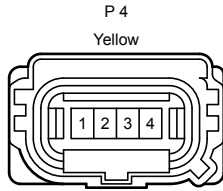
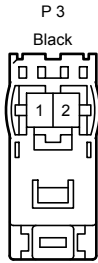
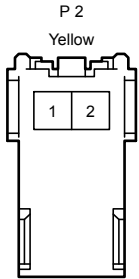
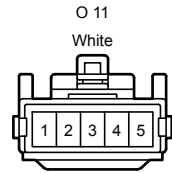
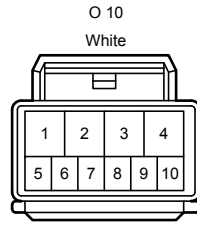
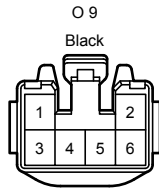
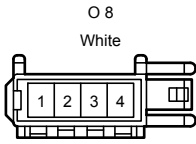
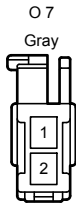



Position of Parts in Body <CrewMax>

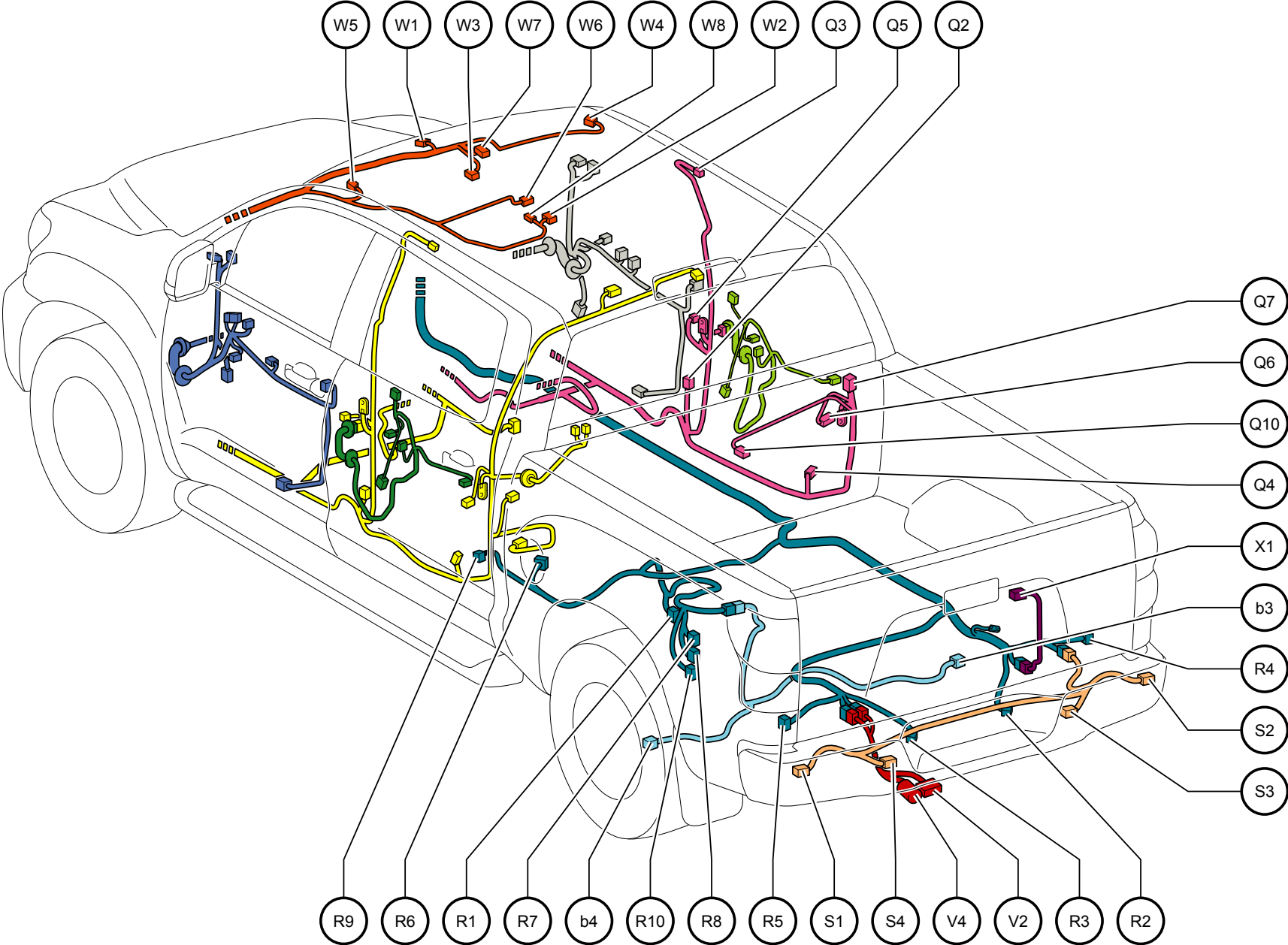

Position of Parts in Body <CrewMax>

---

- Q 2 Front Pretensioner RH
- Q 3 Curtain Shield Airbag Squib Circuit RH
- Q 4 Side Airbag Sensor RH
- Q 5 Front Door Courtesy Switch RH
- Q 6 Rear Door Courtesy Switch RH
- Q 7 Door Control Receiver
- Q 10 Back Door Window Regulator Motor

- R 1 Canister Pump Module
- R 2 License Plate Light RH
- R 3 License Plate Light LH
- R 4 Rear Combination Light RH
- R 5 Rear Combination Light LH
- R 6 Fuel Sender Gauge
- R 7 Fuel Pump Control ECU
- R 8 Fuel Pump Control ECU
- R 9 Fuel Tank Solenoid Valve Assembly
- R 10 Fuel Pump Control ECU

- S 1 No.1 Ultrasonic Sensor (Rear Left)
- S 2 No.1 Ultrasonic Sensor (Rear Right)
- S 3 No.1 Ultrasonic Sensor (Rear Right Center)
- S 4 No.1 Ultrasonic Sensor (Rear Left Center)

- V 2 Trailer Socket
- V 4 Trailer Socket

- W 1 Inner Mirror
- W 2 Television Display
- W 3 Sliding Roof Control ECU
- W 4 Vanity Light RH
- W 5 Vanity Light LH
- W 6 Room Lamp
- W 7 Roof Console Box Assembly
- W 8 Room Lamp

- X 1 Television Camera

- b 3 Rear Speed Sensor RH
- b 4 Rear Speed Sensor LH

Position of Parts in Body <CrewMax>

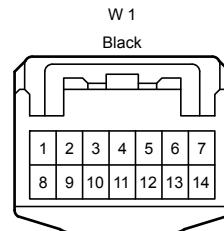
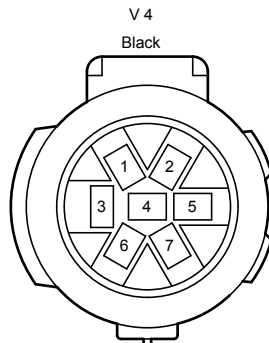
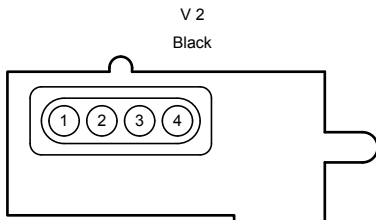
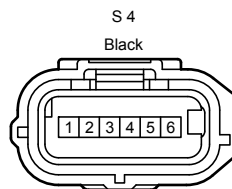
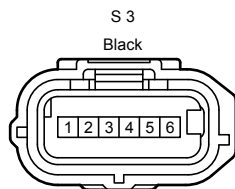
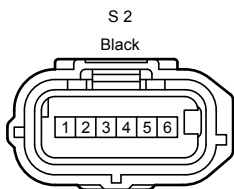
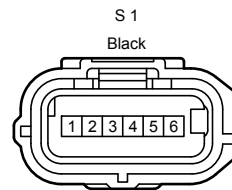
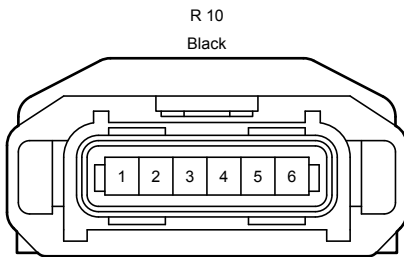
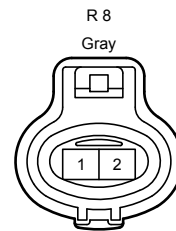
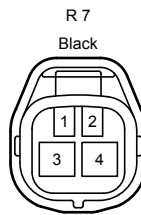
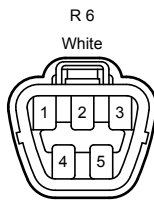
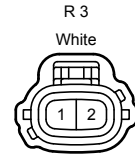
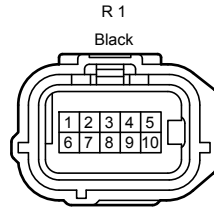
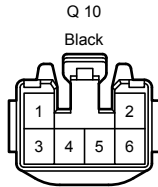
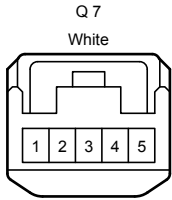
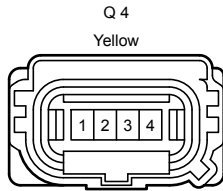
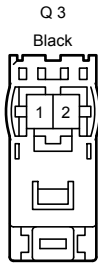
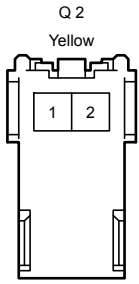

Position of Parts in Body <CrewMax>

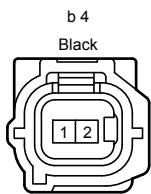
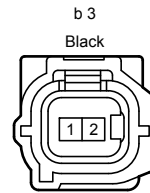
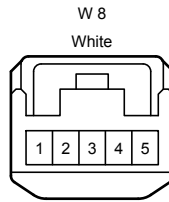
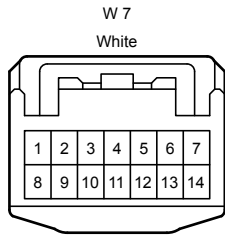
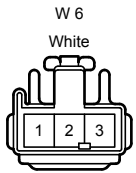
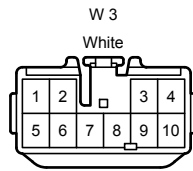
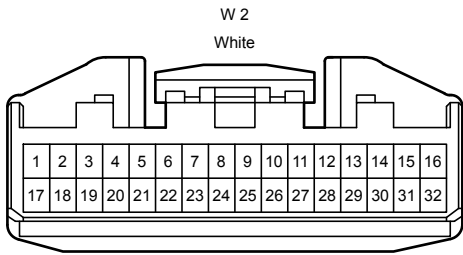

# F RELAY LOCATIONS

---

[Body]  
(CrewMax)

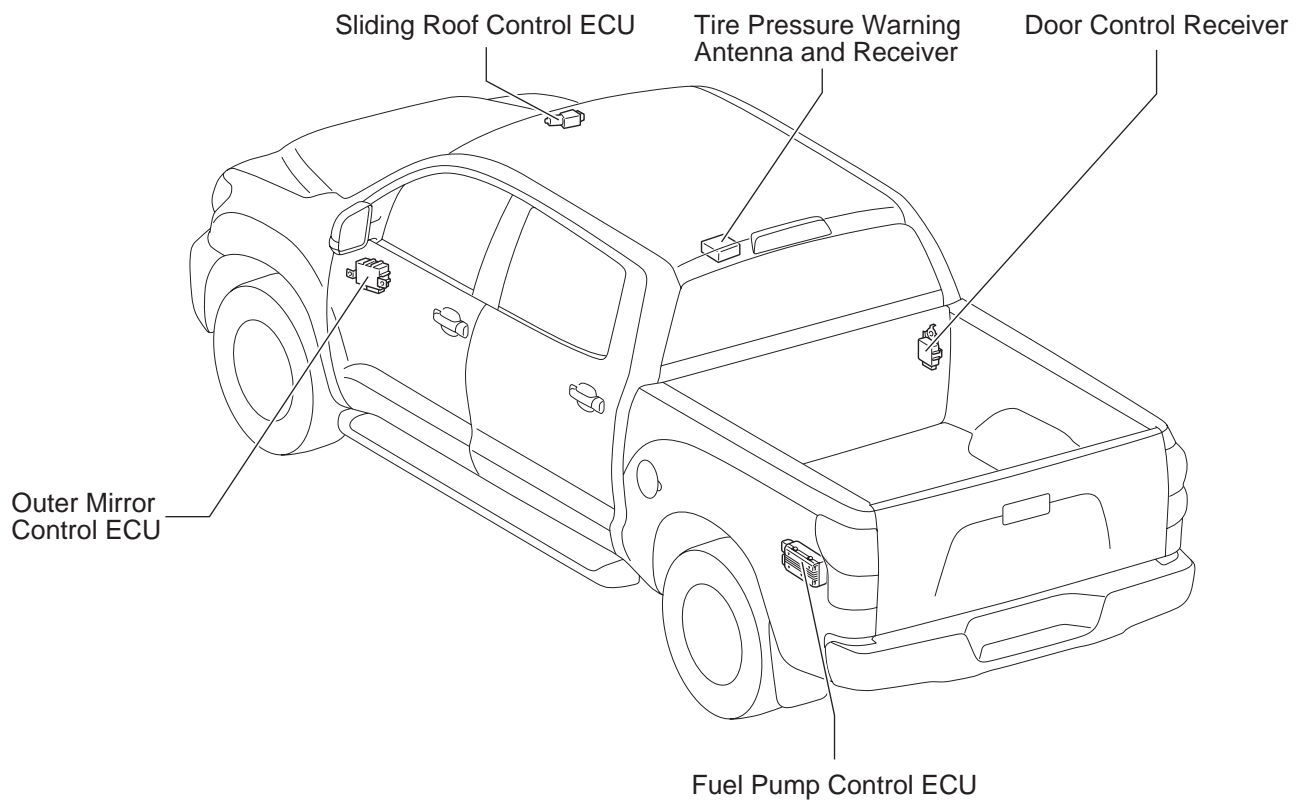

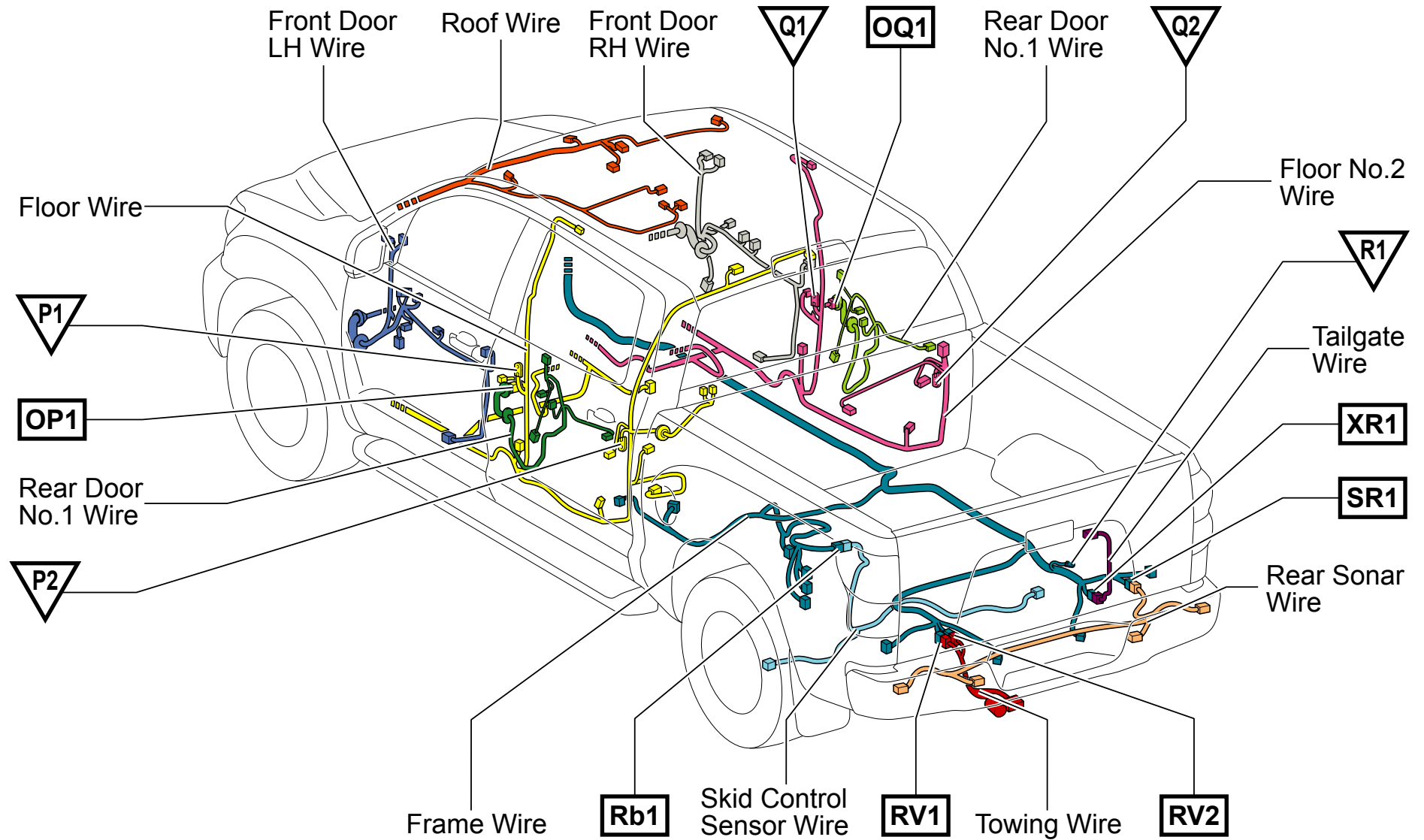

Wire and Wire , Ground Points in Body <CrewMax>

OP1  
White

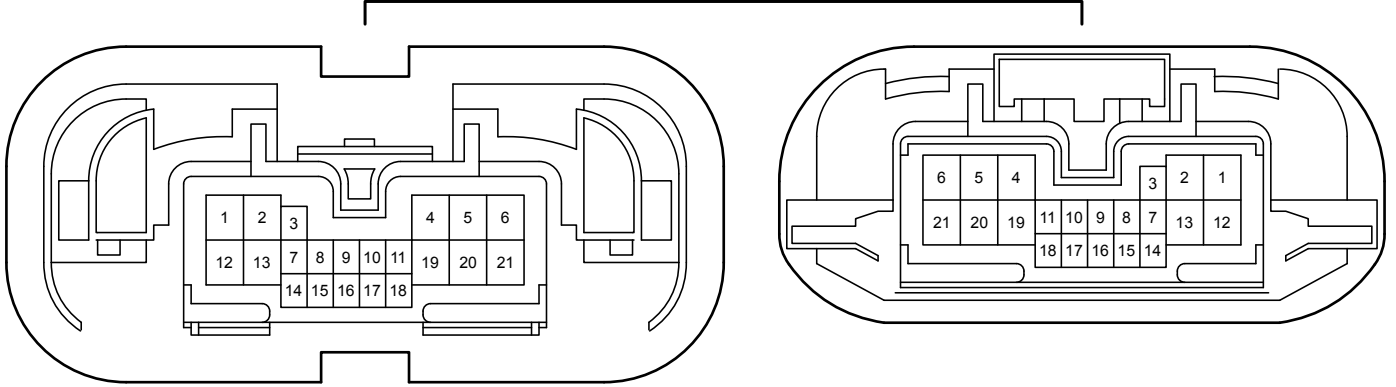

OQ1  
White

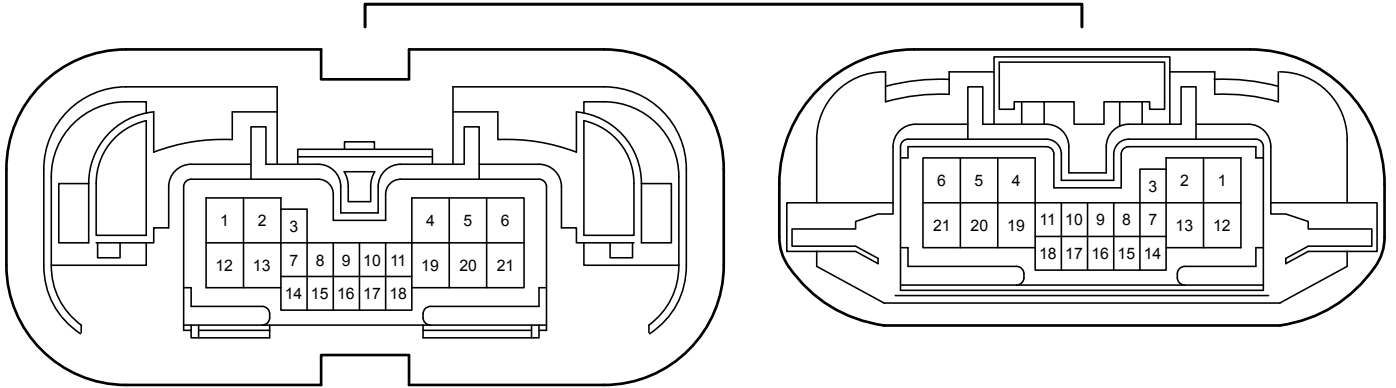

RV1  
Gray

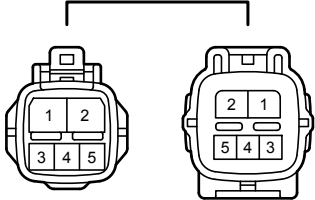

RV2  
Gray

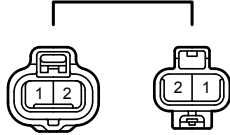

Rb1  
White

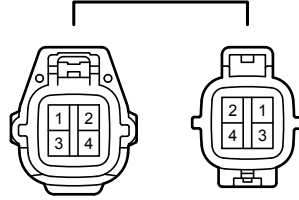

SR1  
Black

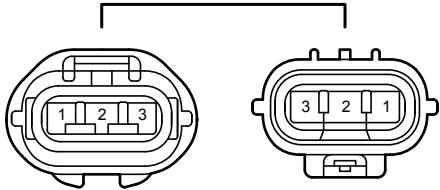

XR1  
White

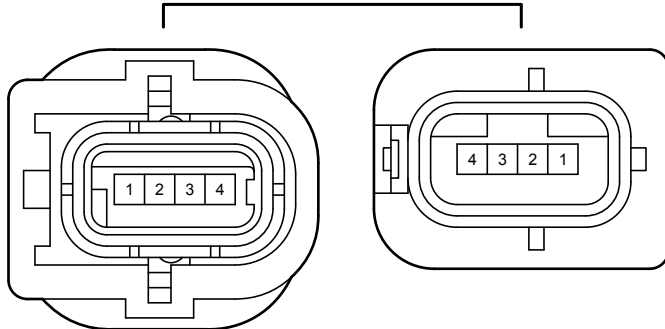

Position of Parts in Body <Double Cab>

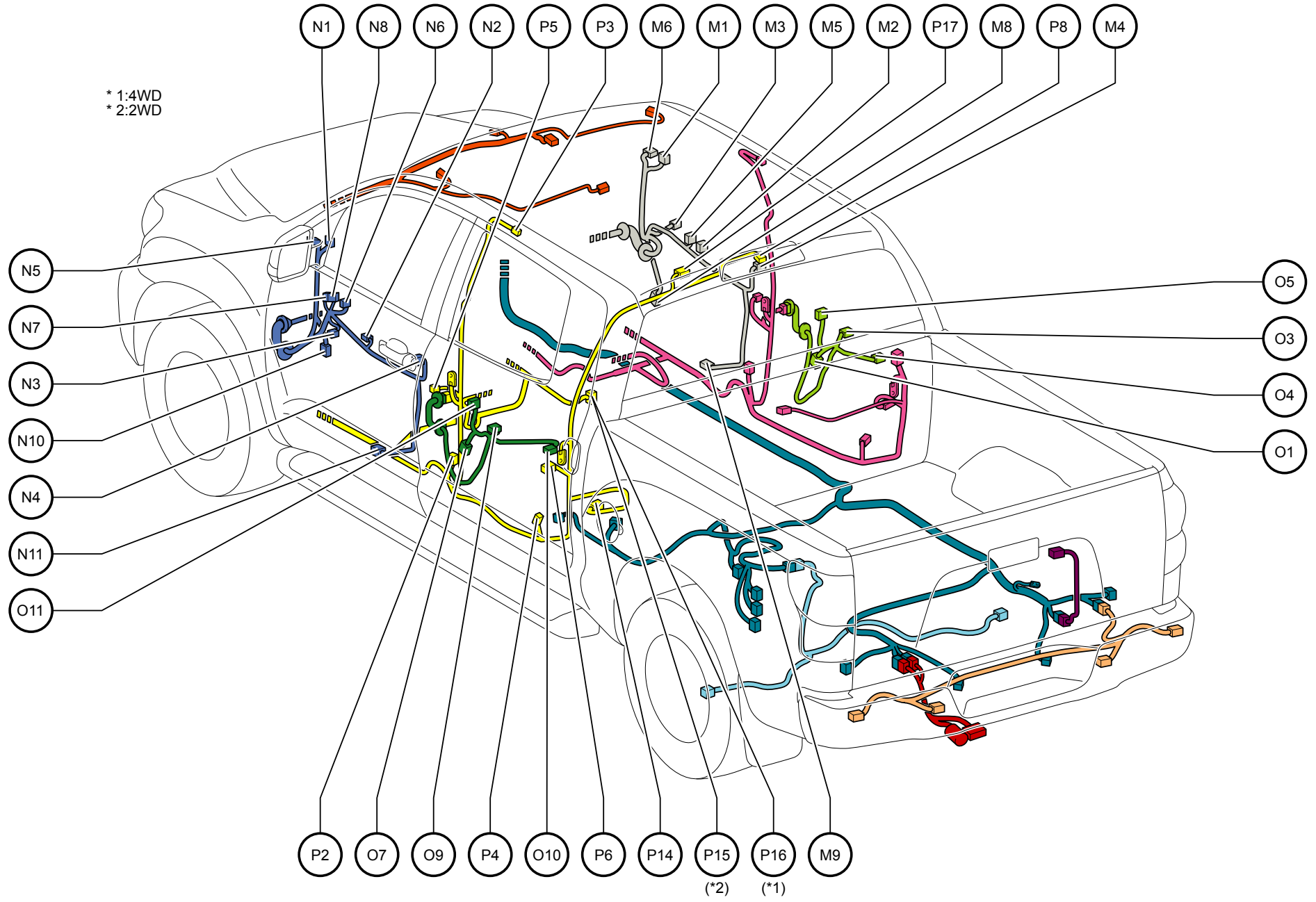



Position of Parts in Body <Double Cab>

---

- M 1 Front Door Tweeter RH
- M 2 Front Power Window Switch RH
- M 3 Front Power Window Regulator Motor RH
- M 4 Front Door Lock Motor RH
- M 5 Front Door Lock Switch RH
- M 6 Outer Rear View Mirror RH
- M 8 Front Door Speaker RH
- M 9 Door Side Airbag Sensor RH
  
- N 1 Front Door Tweeter LH
- N 2 Power Window Regulator Master Switch
- N 3 Front Power Window Regulator Motor LH
- N 4 Front Door Lock Motor LH
- N 5 Outer Rear View Mirror LH
- N 6 Seat Memory Switch
- N 7 Outer Mirror Control ECU
- N 8 Outer Mirror Control ECU
- N 10 Front Door Speaker LH
- N 11 Door Side Airbag Sensor LH
  
- O 1 Rear Door Speaker RH
- O 3 Rear Power Window Regulator Motor RH
- O 4 Rear Door Lock Motor RH
- O 5 Rear Power Window Switch RH
- O 7 Rear Door Speaker LH
- O 9 Rear Power Window Regulator Motor LH
- O 10 Rear Door Lock Motor LH
- O 11 Rear Power Window Switch LH
  
- P 2 Front Pretensioner LH
- P 3 Curtain Shield Airbag Squib Circuit LH
- P 4 Side Airbag Sensor LH
- P 5 Front Door Courtesy Switch LH
- P 6 Rear Door Courtesy Switch LH
- P 8 Cargo Light , High Mounted Stop Light
- P 14 Woofer
- P 15 Yaw Rate Sensor
- P 16 Yaw Rate Sensor
- P 17 Tire Pressure Warning Antenna and Receiver

Position of Parts in Body <Double Cab>

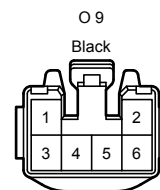
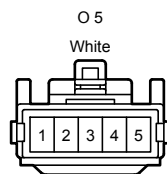
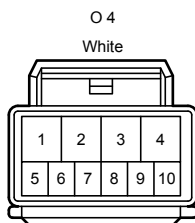
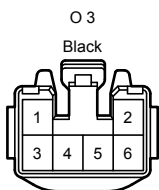
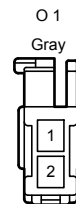
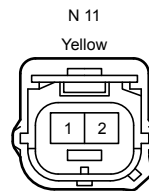
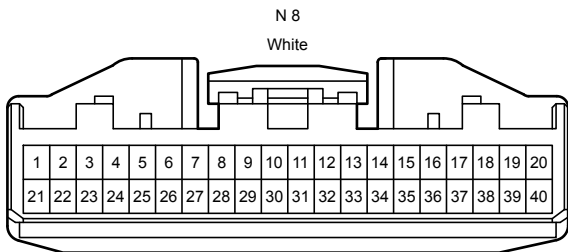
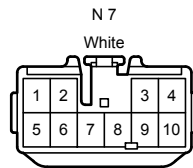
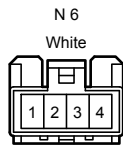
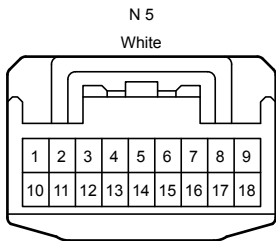
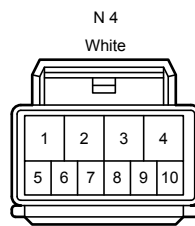
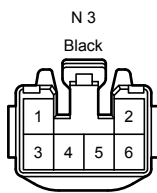
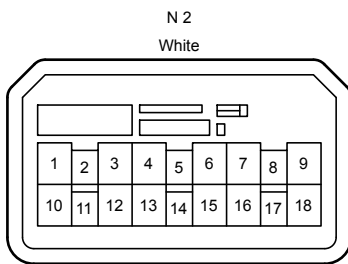
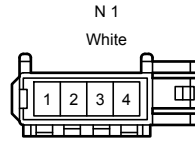
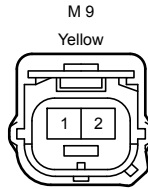
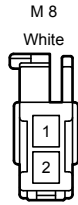
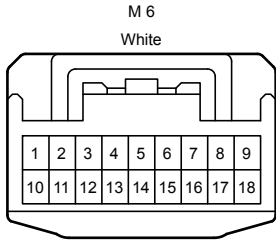
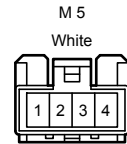
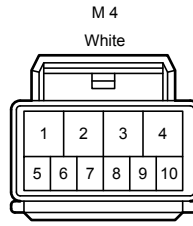
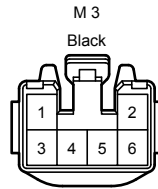
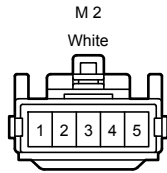
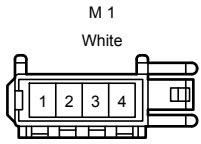

Position of Parts in Body <Double Cab>

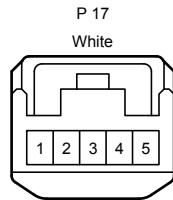
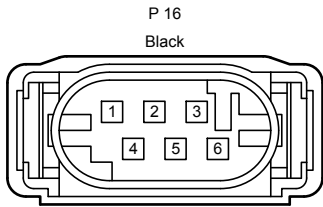
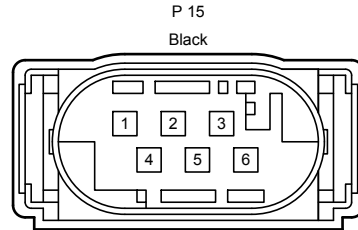
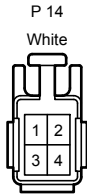
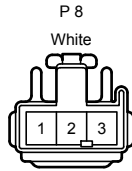
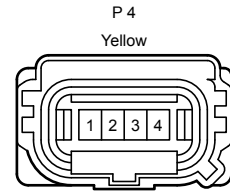
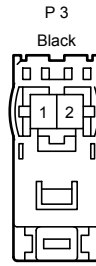
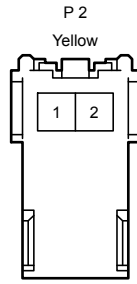
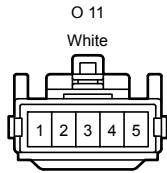
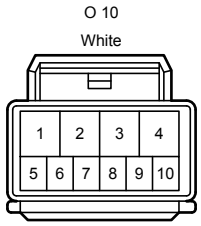

Position of Parts in Body <Double Cab>

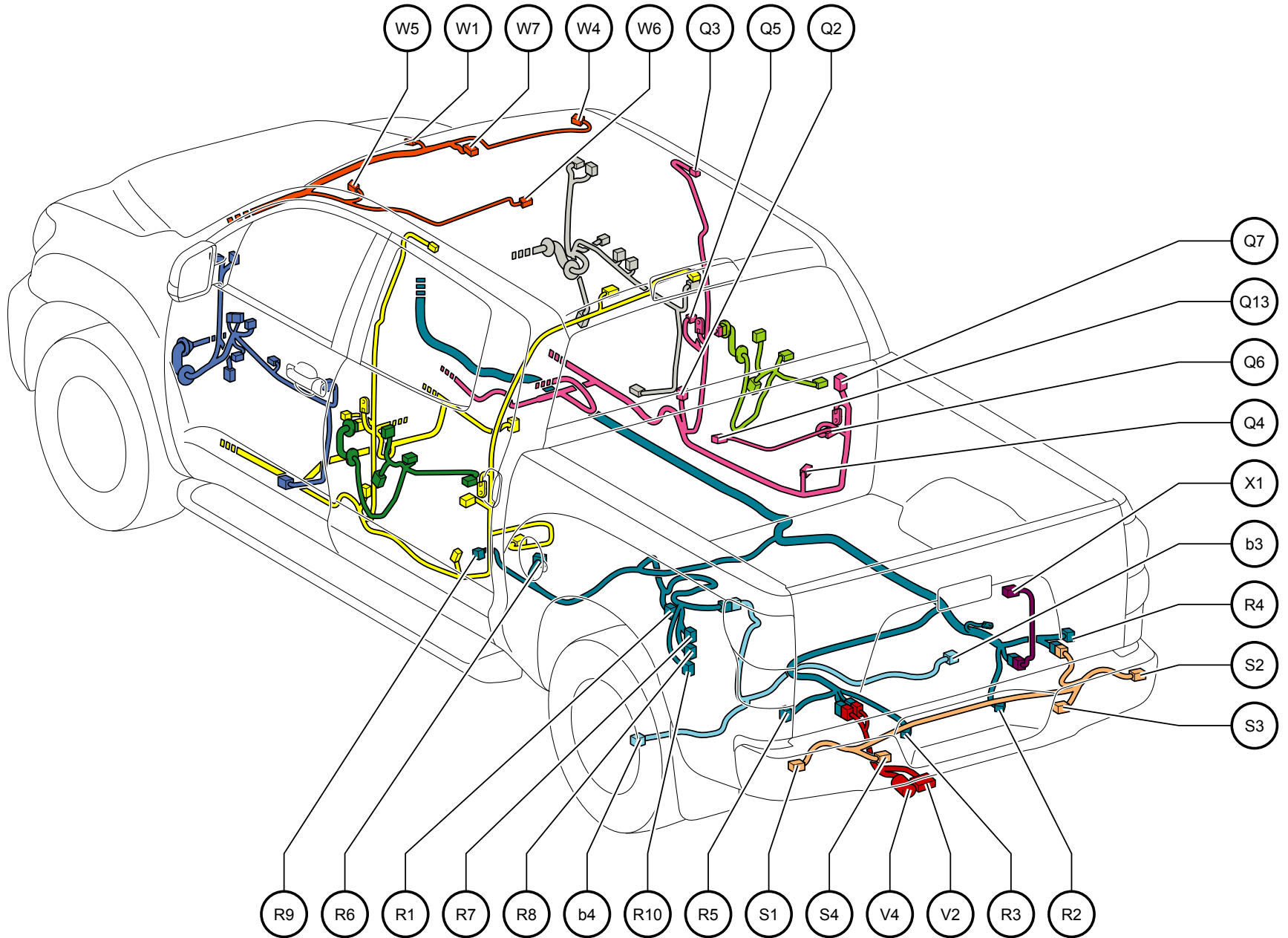

Position of Parts in Body <Double Cab>

---

- Q 2 Front Pretensioner RH
- Q 3 Curtain Shield Airbag Squib Circuit RH
- Q 4 Side Airbag Sensor RH
- Q 5 Front Door Courtesy Switch RH
- Q 6 Rear Door Courtesy Switch RH
- Q 7 Door Control Receiver
- Q 13 Back Door Window Regulator Motor

- R 1 Canister Pump Module
- R 2 License Plate Light RH
- R 3 License Plate Light LH
- R 4 Rear Combination Light RH
- R 5 Rear Combination Light LH
- R 6 Fuel Sender Gauge
- R 7 Fuel Pump Control ECU
- R 8 Fuel Pump Control ECU
- R 9 Fuel Tank Solenoid Valve Assembly
- R 10 Fuel Pump Control ECU

- S 1 No.1 Ultrasonic Sensor (Rear Left)
- S 2 No.1 Ultrasonic Sensor (Rear Right)
- S 3 No.1 Ultrasonic Sensor (Rear Right Center)
- S 4 No.1 Ultrasonic Sensor (Rear Left Center)

- V 2 Trailer Socket
- V 4 Trailer Socket

- W 1 Inner Mirror
- W 4 Vanity Light RH
- W 5 Vanity Light LH
- W 6 Room Lamp
- W 7 Roof Console Box Assembly

- X 1 Television Camera

- b 3 Rear Speed Sensor RH
- b 4 Rear Speed Sensor LH

Position of Parts in Body <Double Cab>

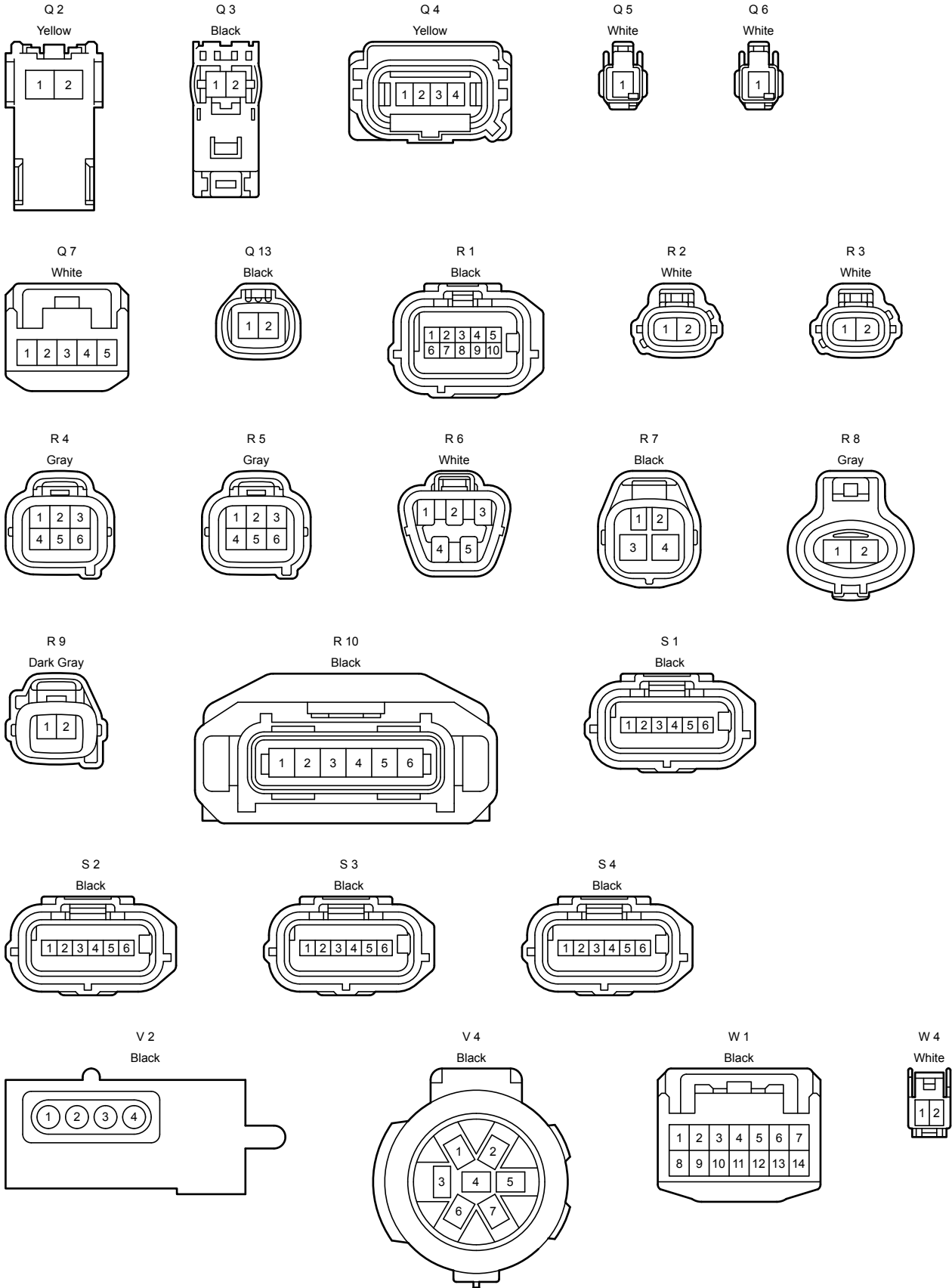

Position of Parts in Body <Double Cab>

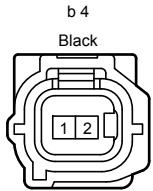
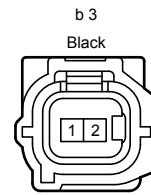
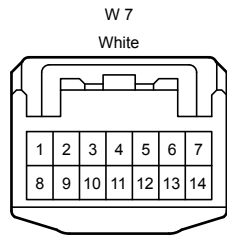
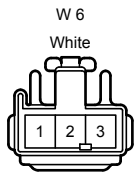
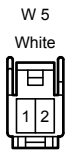

**(Double Cab)**

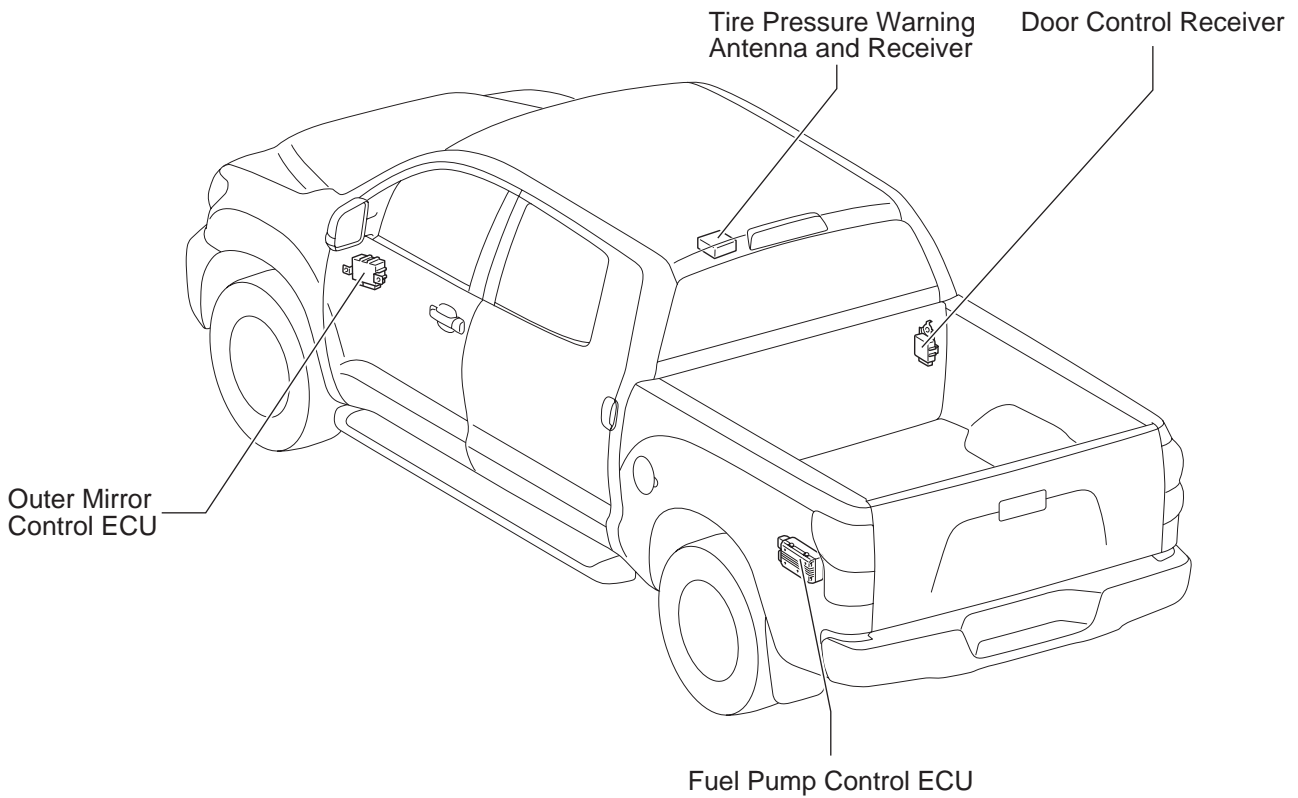

**(Regular Cab)**

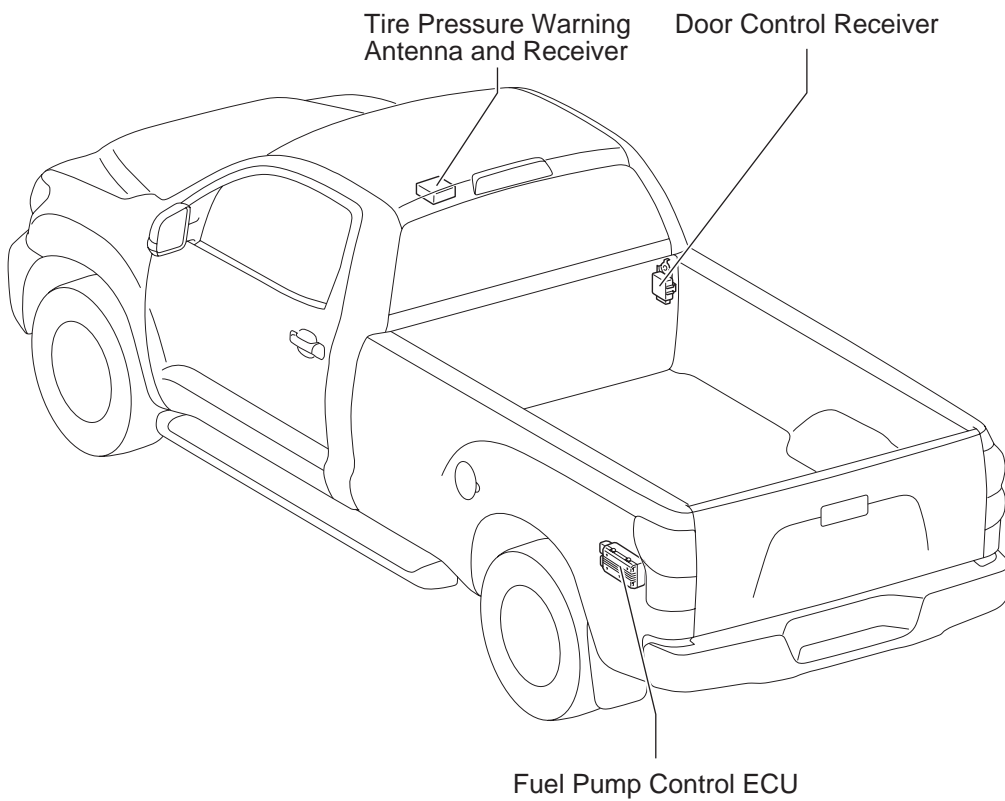



Wire and Wire , Ground Points in Body <Double Cab>

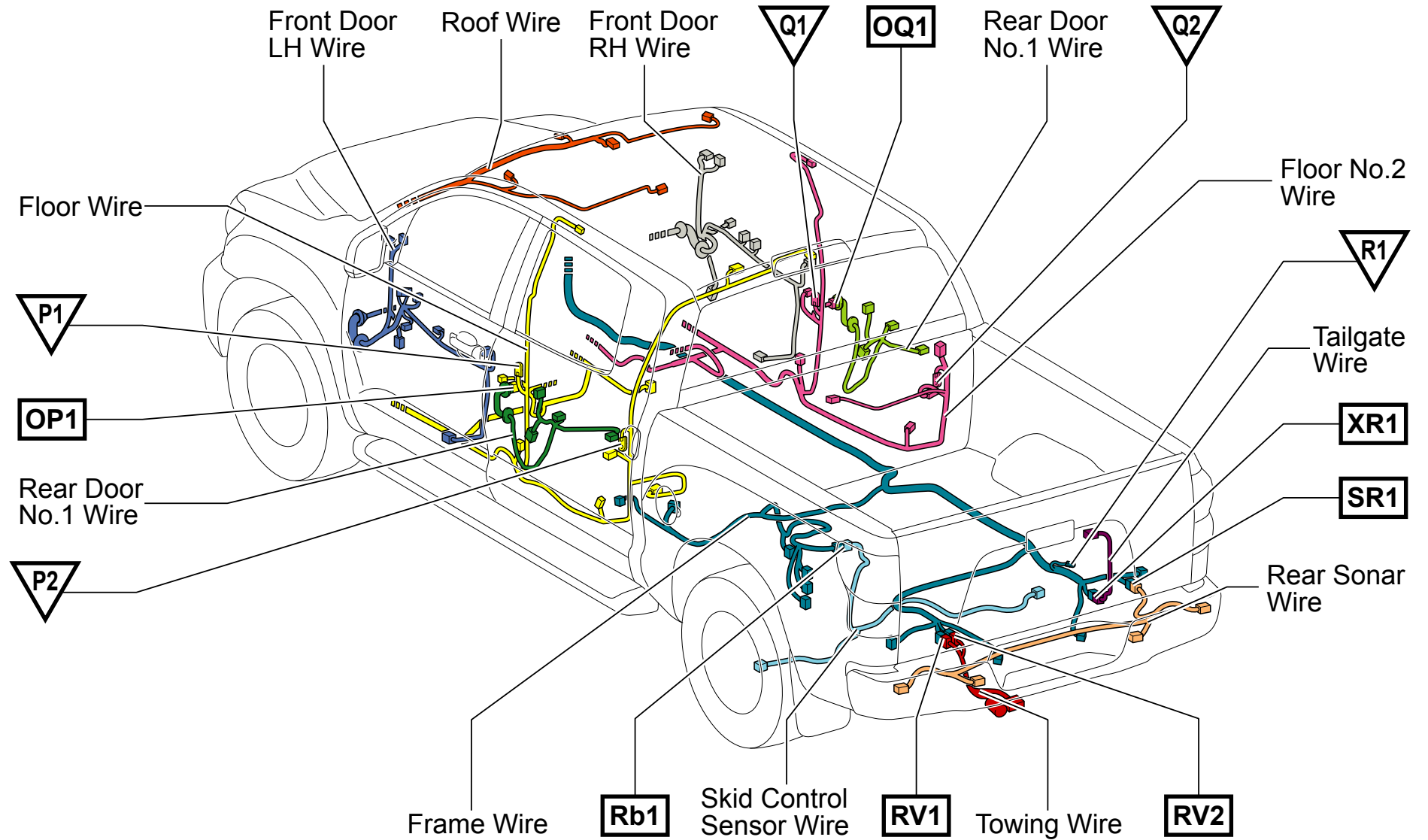

Wire and Wire , Ground Points in Body <Double Cab>

OP1  
White

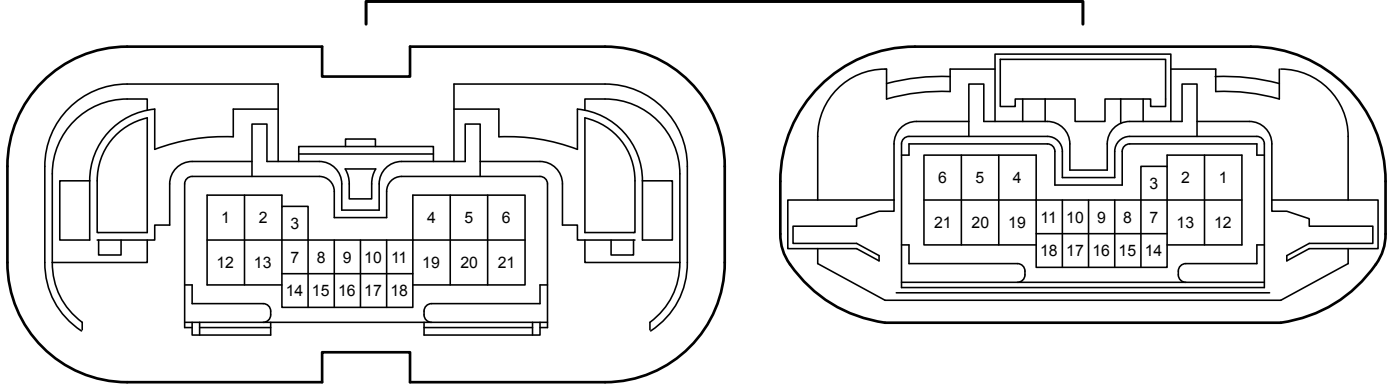

OQ1  
White

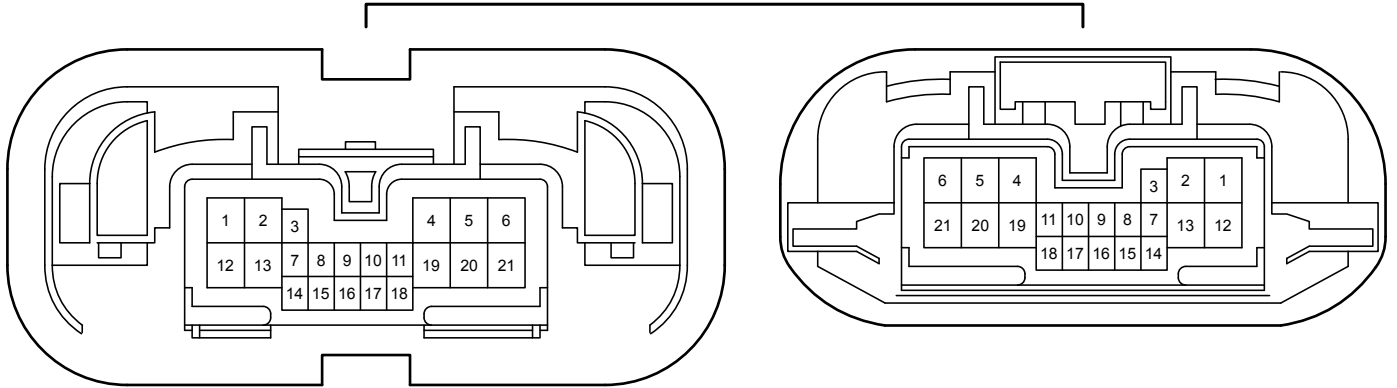

RV1  
Gray

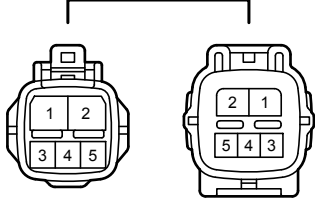

RV2  
Gray

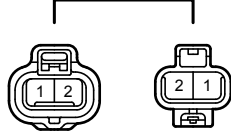

Rb1  
White

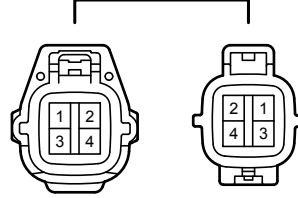

SR1  
Black

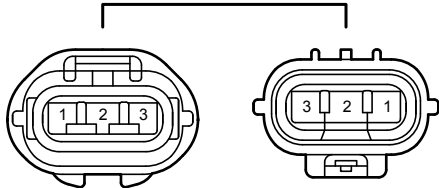

XR1  
White

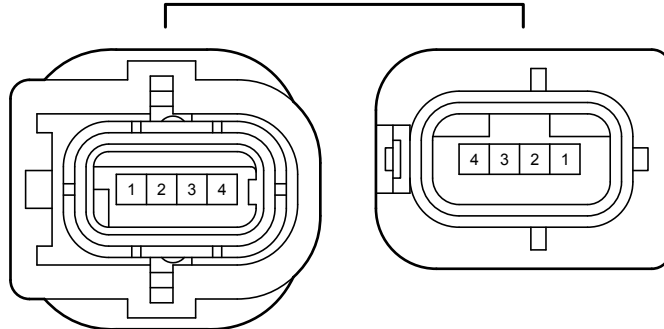

Position of Parts in Body <Regular Cab>

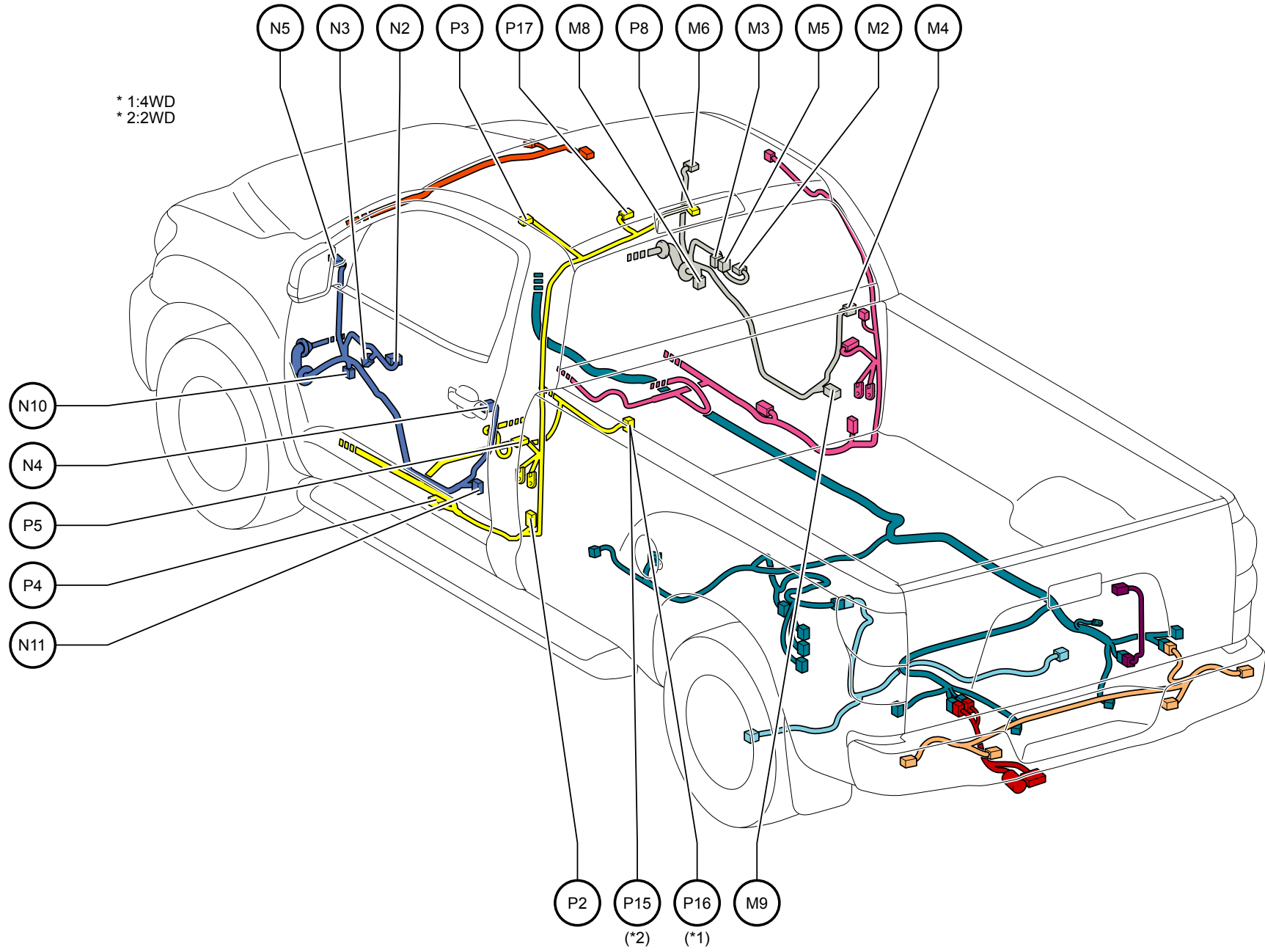

Position of Parts in Body <Regular Cab>

---

- M 2 Front Power Window Switch RH
- M 3 Front Power Window Regulator Motor RH
- M 4 Front Door Lock Motor RH
- M 5 Front Door Lock Switch RH
- M 6 Outer Rear View Mirror RH
- M 8 Front Door Speaker RH
- M 9 Door Side Airbag Sensor RH
  
- N 2 Power Window Regulator Master Switch
- N 3 Front Power Window Regulator Motor LH
- N 4 Front Door Lock Motor LH
- N 5 Outer Rear View Mirror LH
- N 10 Front Door Speaker LH
- N 11 Door Side Airbag Sensor LH
  
- P 2 Front Pretensioner LH
- P 3 Curtain Shield Airbag Squib Circuit LH
- P 4 Side Airbag Sensor LH
- P 5 Front Door Courtesy Switch LH
- P 8 Cargo Light , High Mounted Stop Light
- P 15 Yaw Rate Sensor
- P 16 Yaw Rate Sensor
- P 17 Tire Pressure Warning Antenna and Receiver

Position of Parts in Body <Regular Cab>

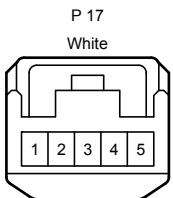
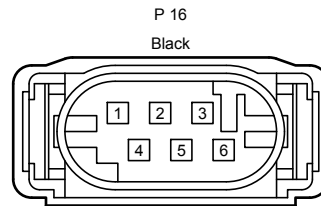
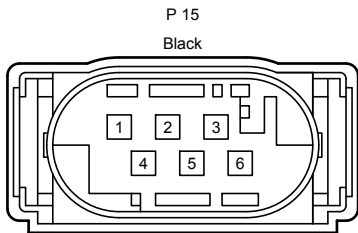
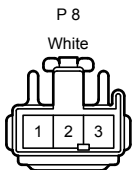
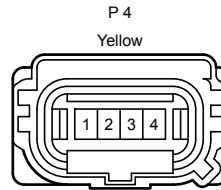
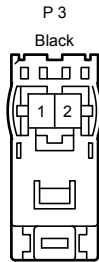
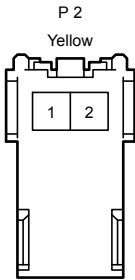
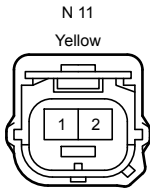
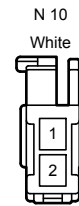
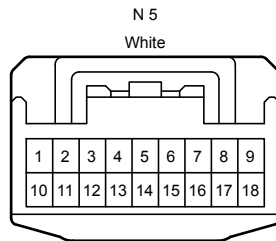
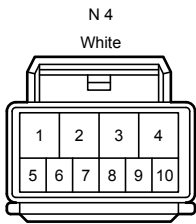
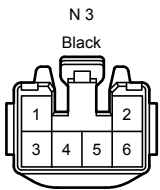
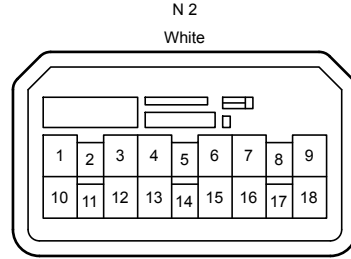
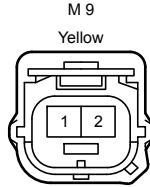
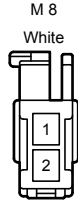
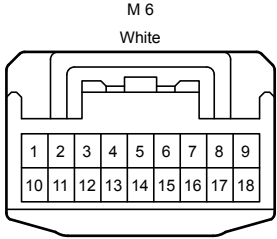
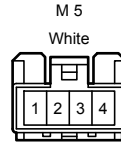
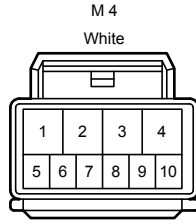
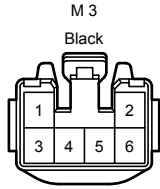
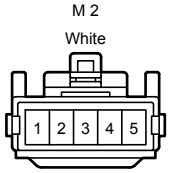

Position of Parts in Body <Regular Cab>

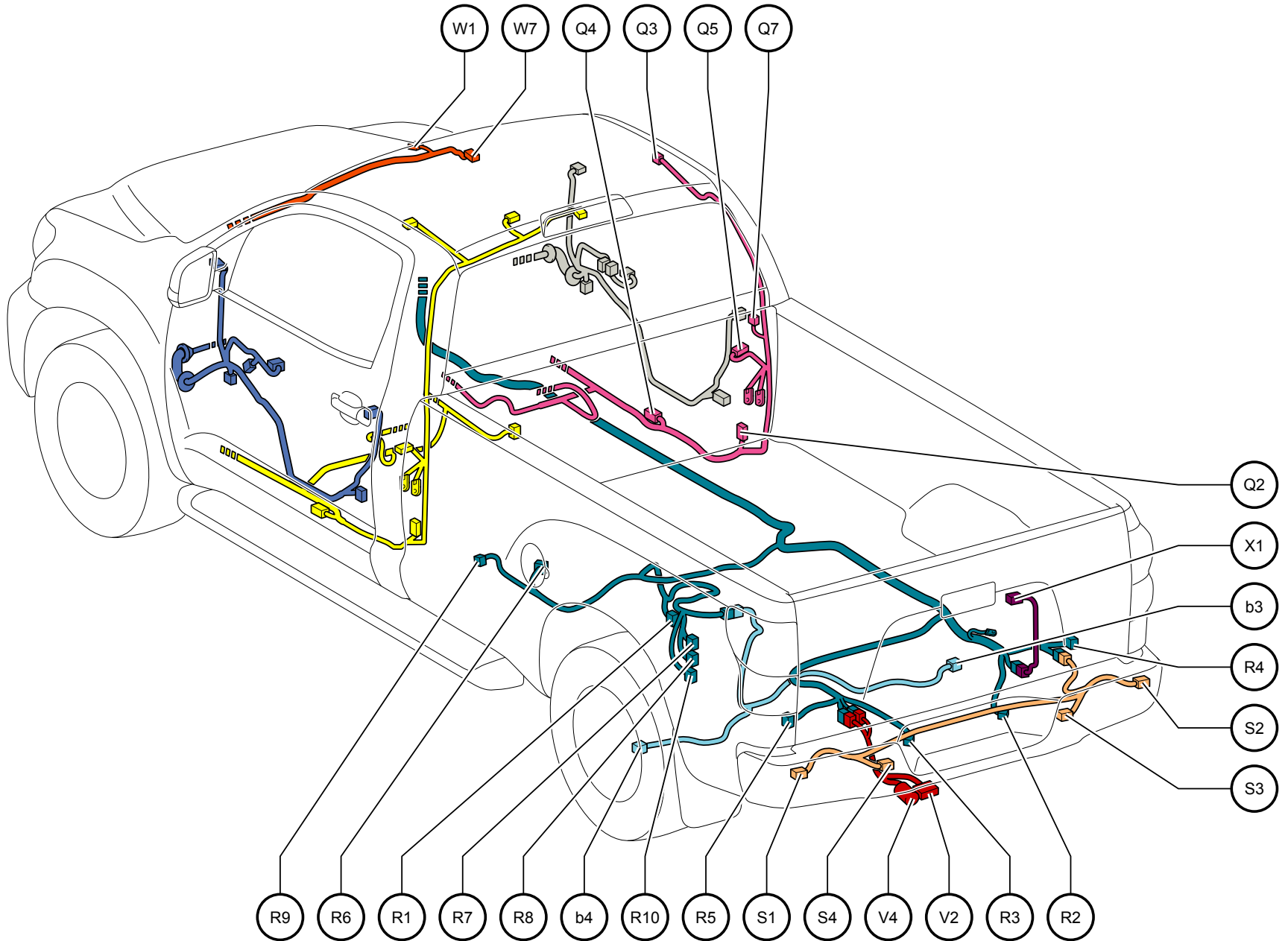

Position of Parts in Body <Regular Cab>

---

- Q 2 Front Pretensioner RH
- Q 3 Curtain Shield Airbag Squib Circuit RH
- Q 4 Side Airbag Sensor RH
- Q 5 Front Door Courtesy Switch RH
- Q 7 Door Control Receiver

- R 1 Canister Pump Module
- R 2 License Plate Light RH
- R 3 License Plate Light LH
- R 4 Rear Combination Light RH
- R 5 Rear Combination Light LH
- R 6 Fuel Sender Gauge
- R 7 Fuel Pump Control ECU
- R 8 Fuel Pump Control ECU
- R 9 Fuel Tank Solenoid Valve Assembly
- R 10 Fuel Pump Control ECU

- S 1 No.1 Ultrasonic Sensor (Rear Left)
- S 2 No.1 Ultrasonic Sensor (Rear Right)
- S 3 No.1 Ultrasonic Sensor (Rear Right Center)
- S 4 No.1 Ultrasonic Sensor (Rear Left Center)

- V 2 Trailer Socket
- V 4 Trailer Socket

- W 1 Inner Mirror
- W 7 Roof Console Box Assembly

- X 1 Television Camera

- b 3 Rear Speed Sensor RH
- b 4 Rear Speed Sensor LH

Position of Parts in Body <Regular Cab>

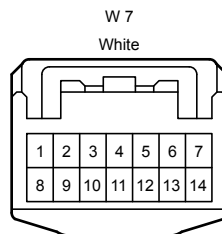
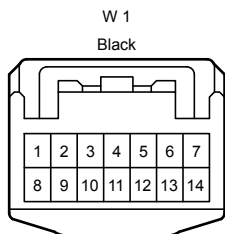
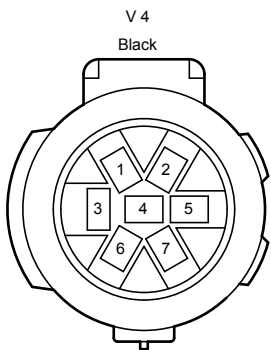
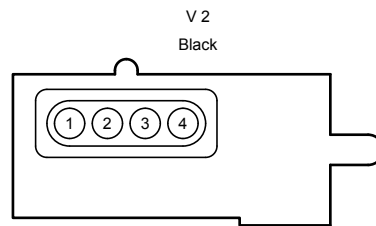
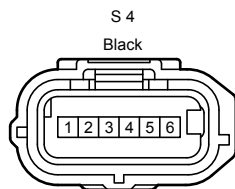
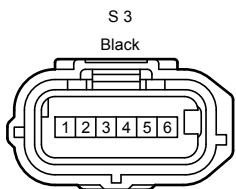
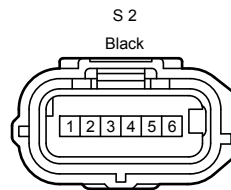
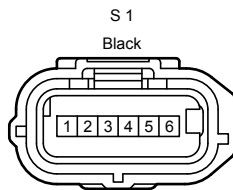
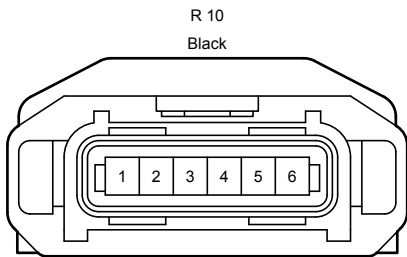
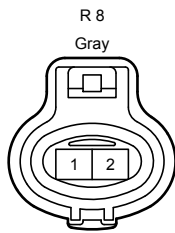
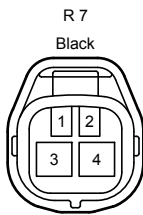
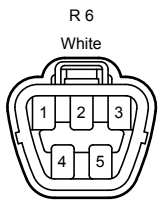
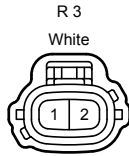
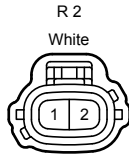
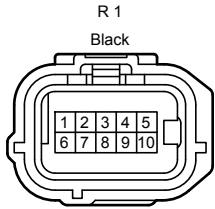
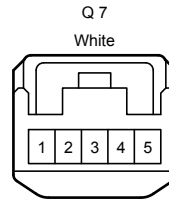
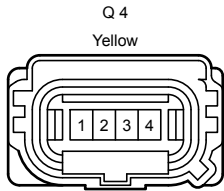
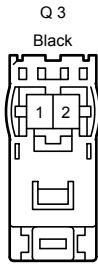
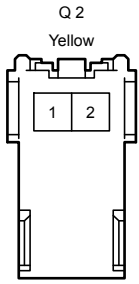



Position of Parts in Body <Regular Cab>

---

b 3  
Black

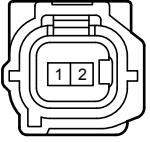

b 4  
Black

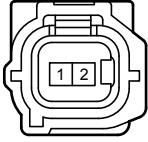

**(Double Cab)**

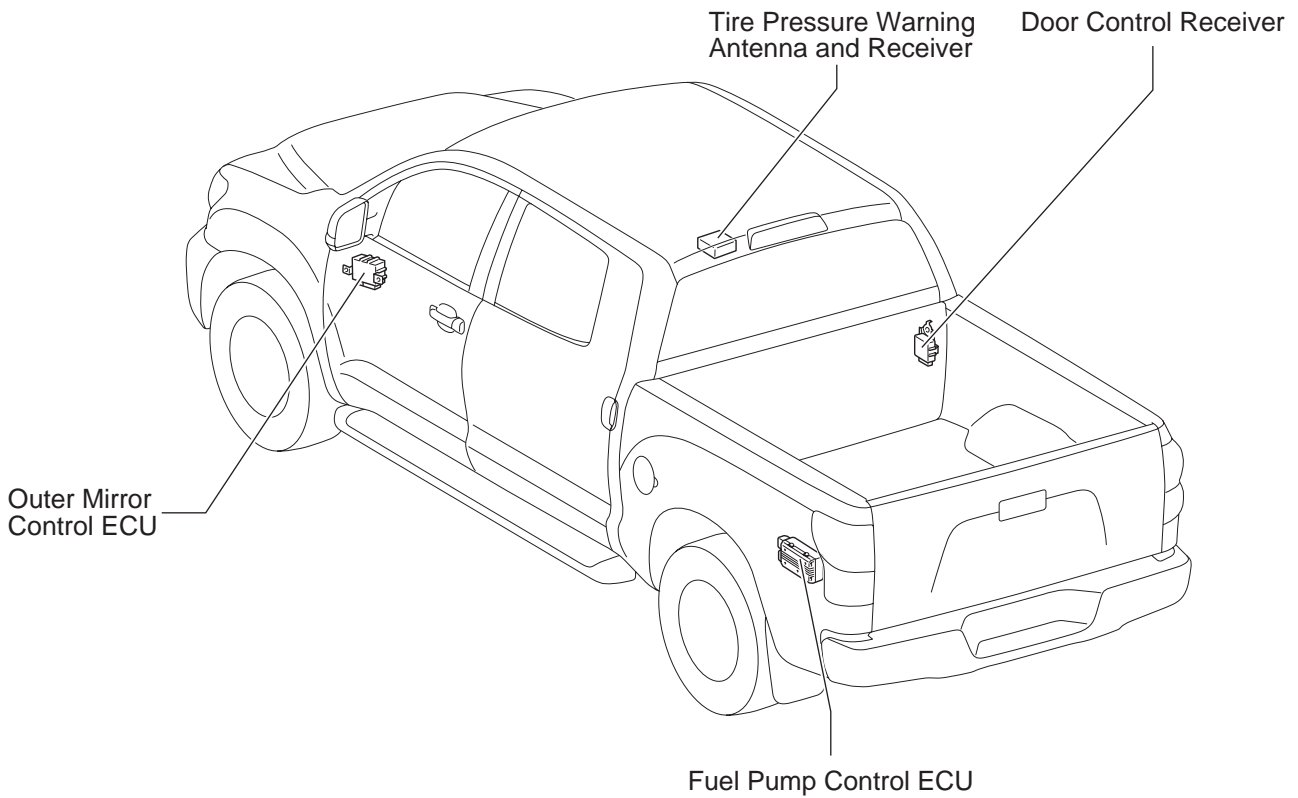

**(Regular Cab)**

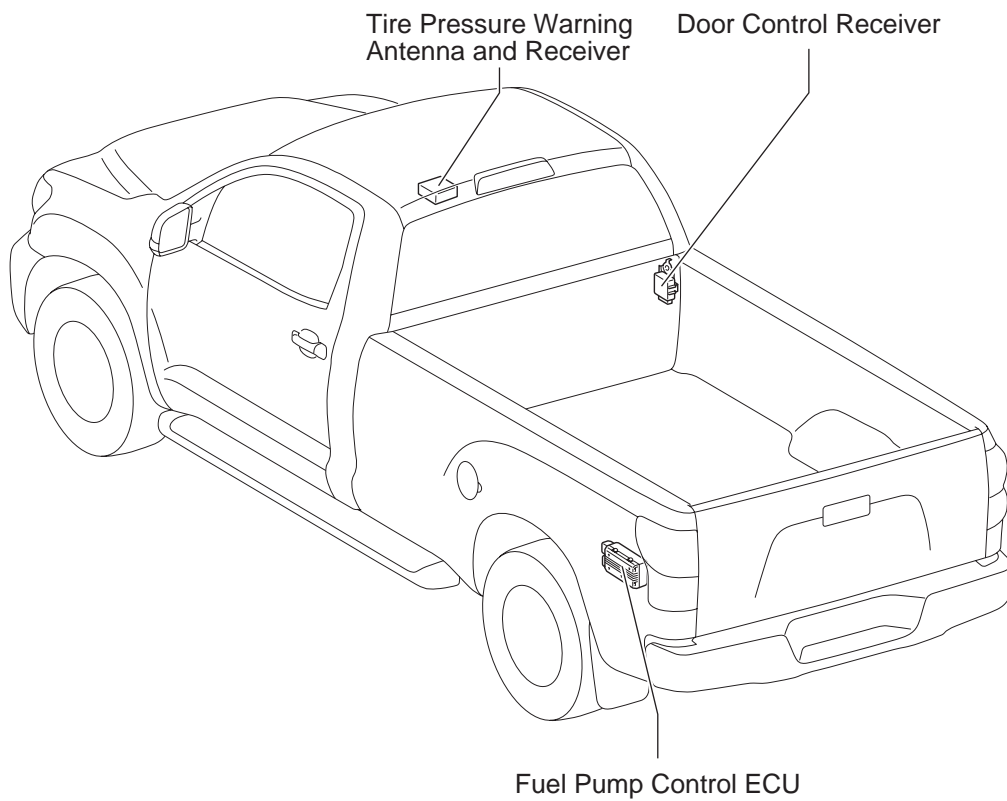

Wire and Wire , Ground Points in Body <Regular Cab>

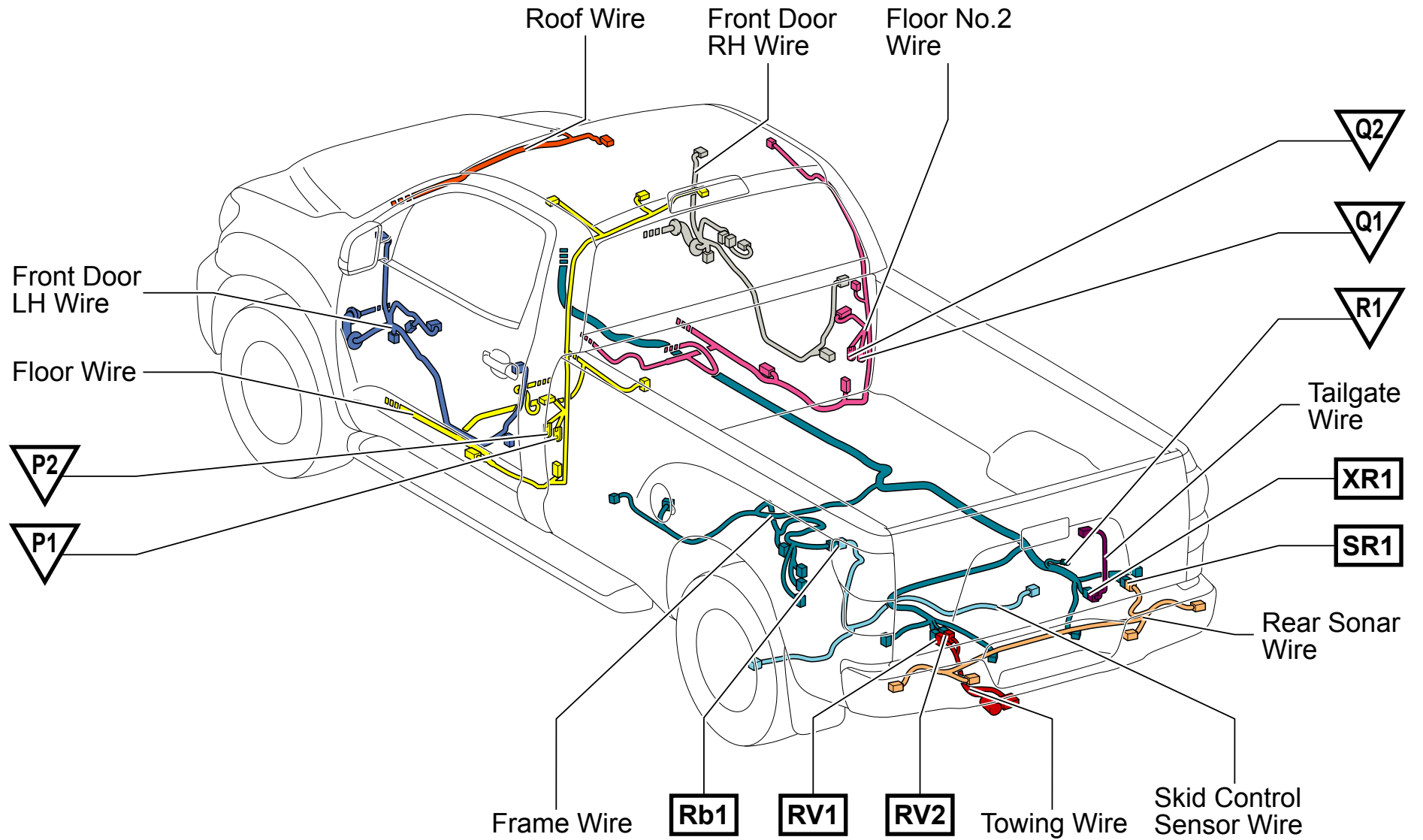

Wire and Wire , Ground Points in Body <Regular Cab>

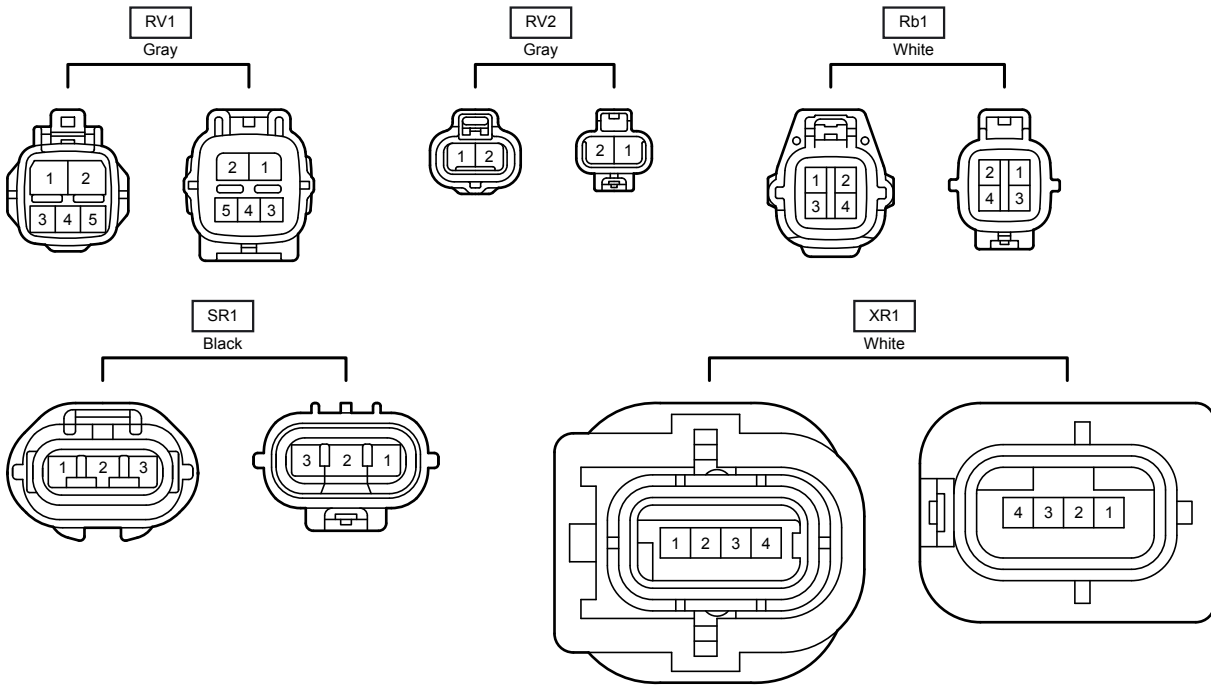

# F RELAY LOCATIONS

○ : Driver Side J/B

Cowl Side Left (See Page 21)

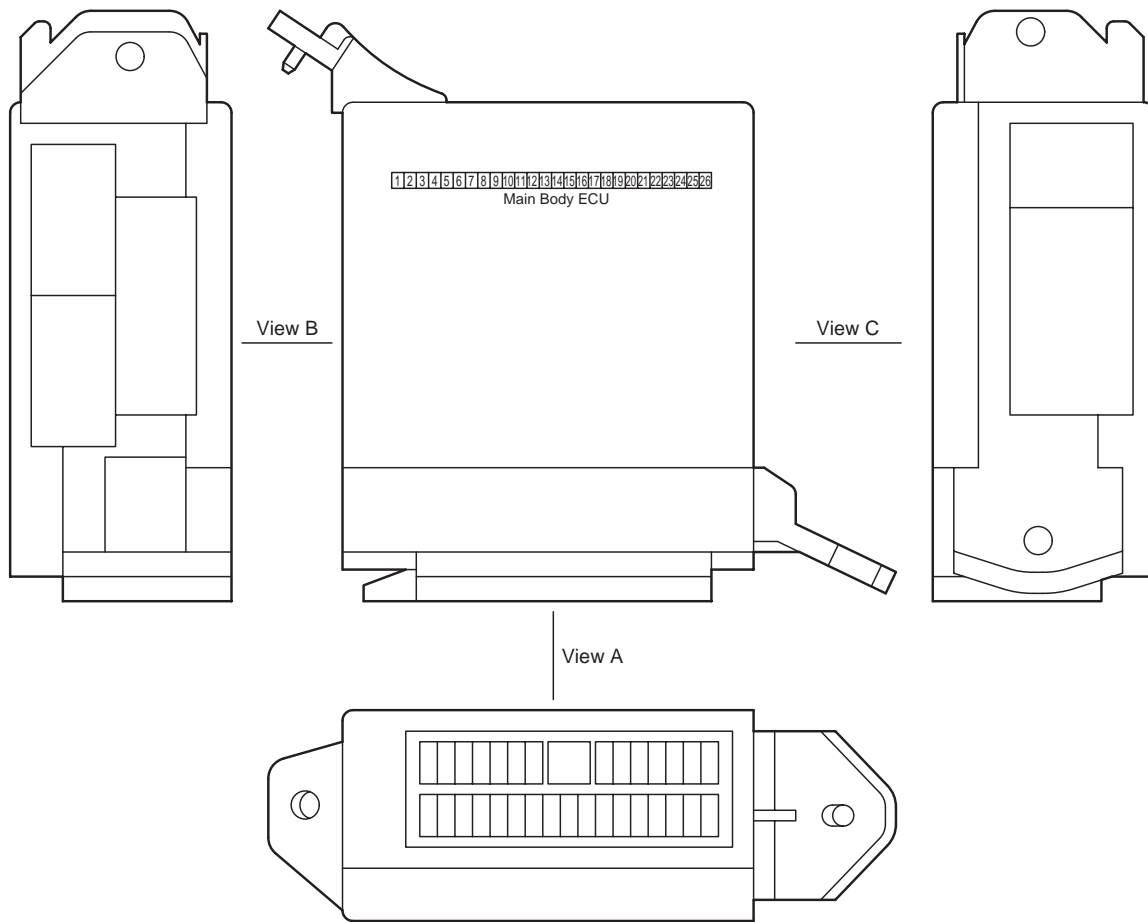



# F RELAY LOCATIONS

○ : Driver Side J/B

Cowl Side Left (See Page 21)

View B

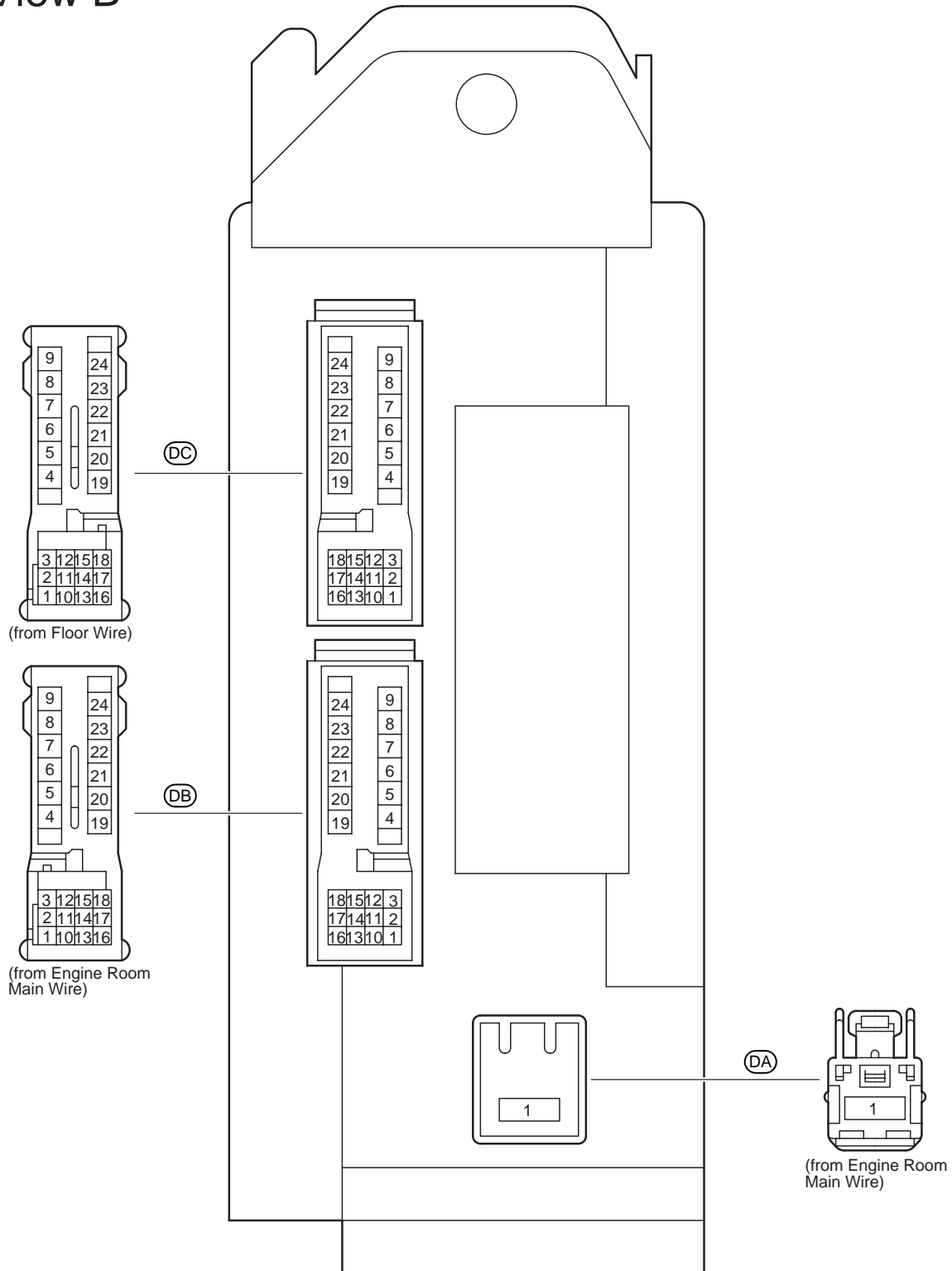

View C

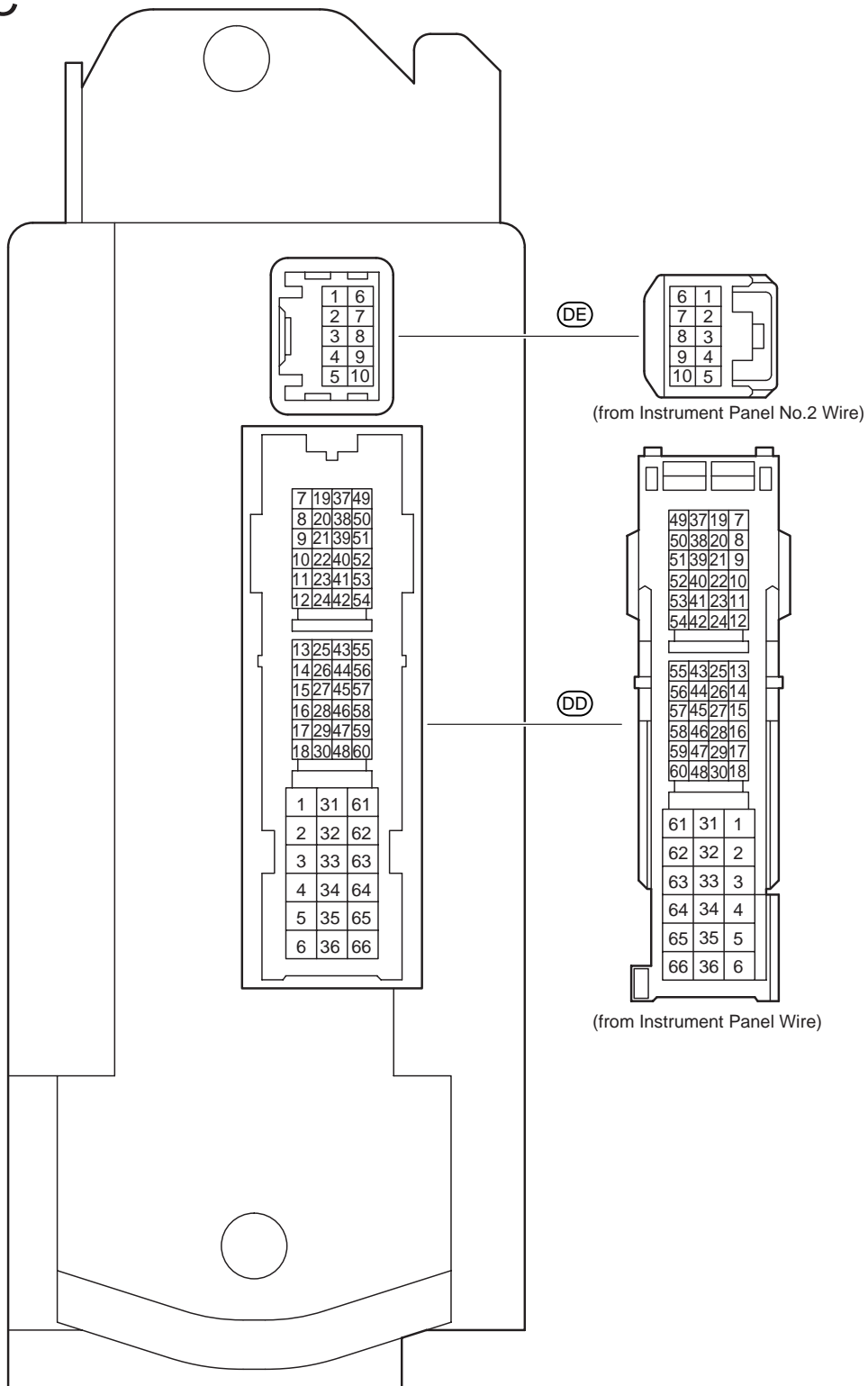



# F RELAY LOCATIONS

## [Driver Side J/B Inner Circuit]

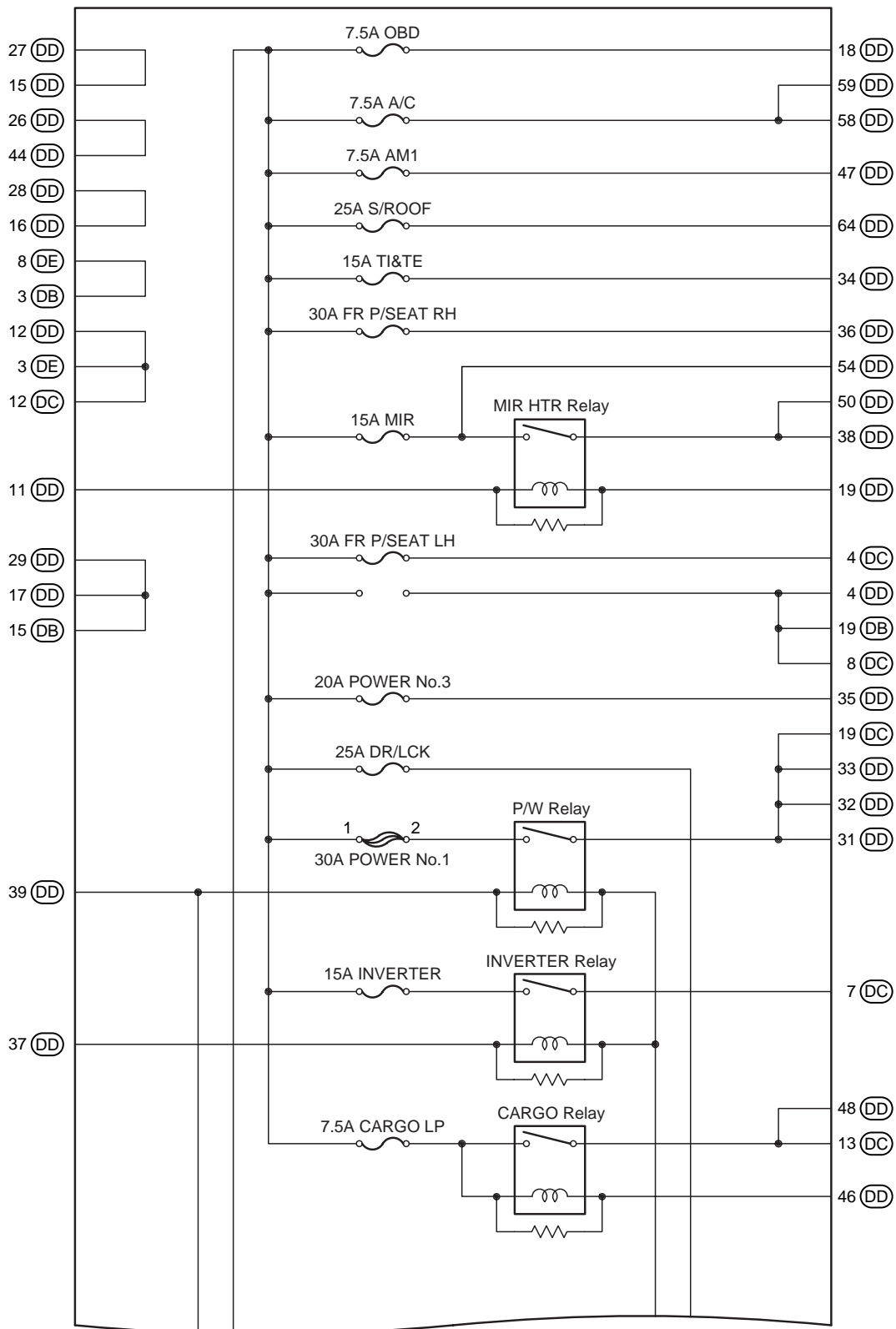

(Cont. Next Page)

(Cont'd)

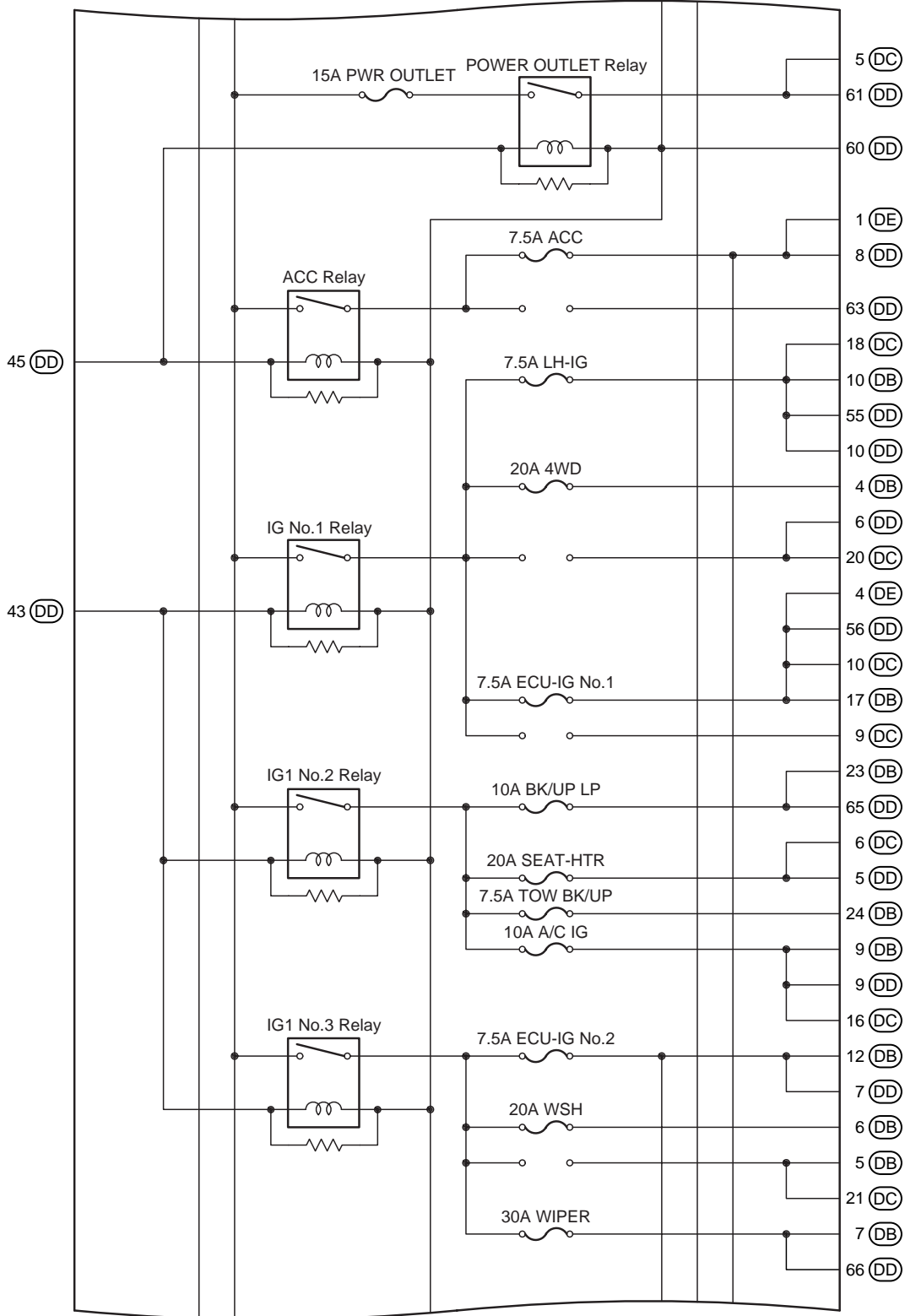

(Cont. Next Page)

# F RELAY LOCATIONS

## [Driver Side J/B Inner Circuit]

(Cont'd)

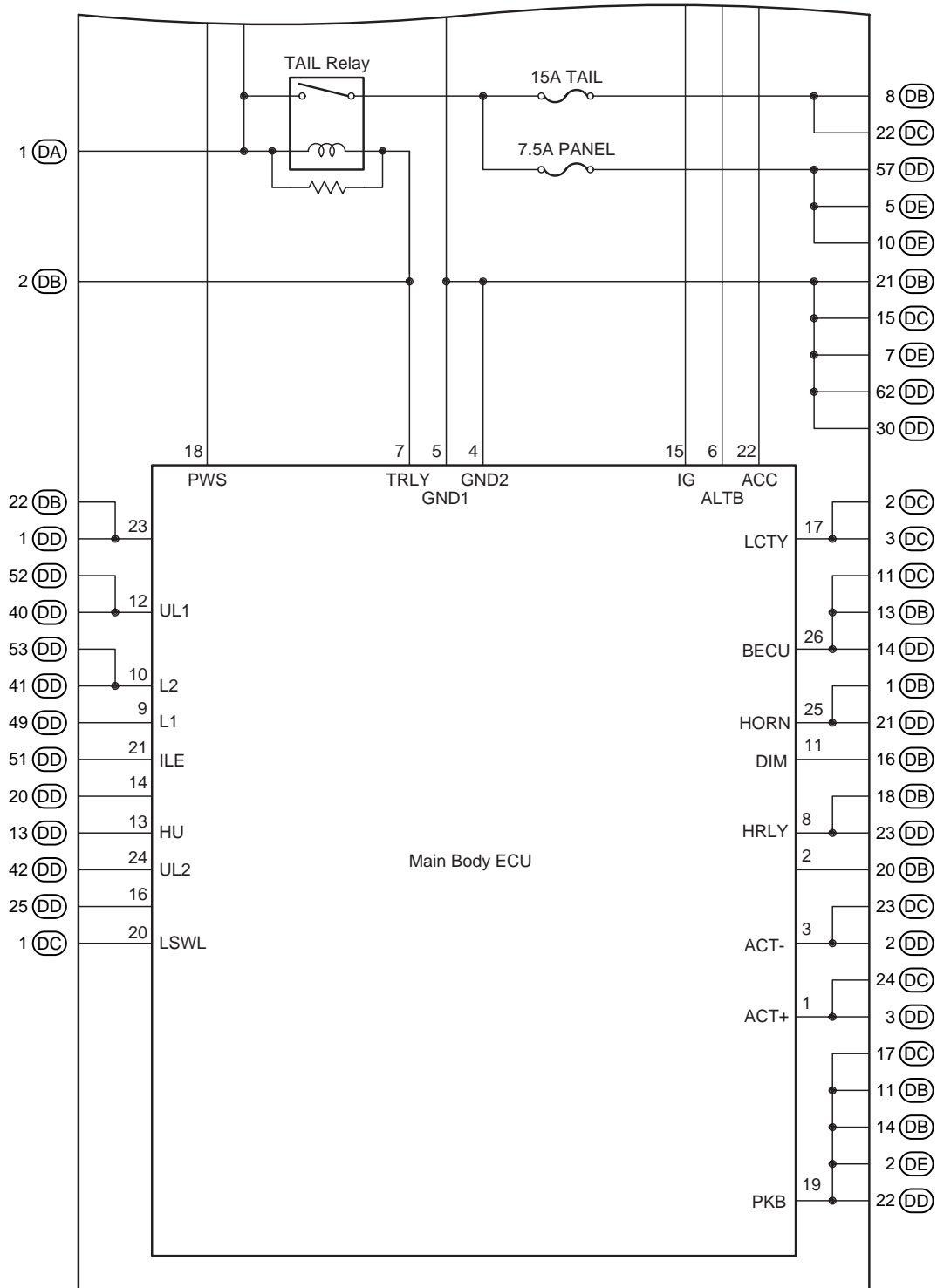

# F RELAY LOCATIONS

## [Engine Compartment]

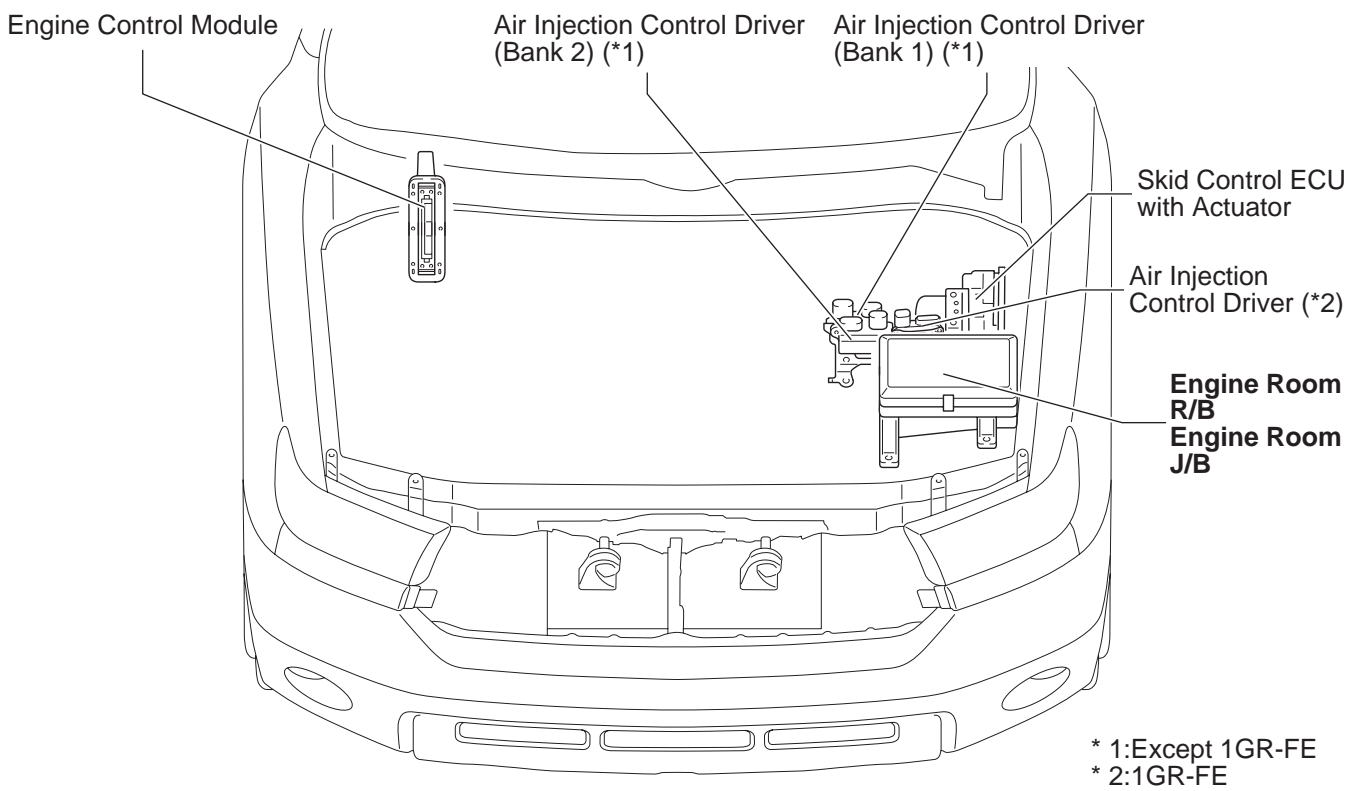

# F RELAY LOCATIONS

<b>① : Engine Room R/B</b> <b>○ : Engine Room J/B</b>	<b>Engine Compartment Left (See Page 20)</b>
--	--

- \* 1:SUB BATT Relay
- \* 2:TOW TAIL Relay
- \* 3:SECURITY HORN Relay
- \* 4:FOG Relay
- \* 5:ST Relay
- \* 6:AI-VSV Relay (1GR-FE)
- \* 7:MG CLT Relay
- \* 8:DEICER Relay
- \* 10:BRK NO.2 Relay
- \* 11:DIM Relay
- \* 12:HEAD Relay
- \* 13:50A HTR  
(for High Current)
- \* 14:40A MAIN  
(for High Current)
- \* 15:50A A/PUMP NO.2  
(for High Current)
- \* 16:50A A/PUMP NO.1  
(for High Current)
- \* 17:140A ALT  
(1GR-FE)  
180A ALT  
(3UR-FE, 3UR-FBE,  
1UR-FE)  
(for High Current)
- \* 18:F/PMP Relay
- \* 19:150A LH-J/B  
(for High Current)
- \* 20:DEFOG Relay

- \* 21:BACK P/W NO.1 Relay  
(Except 3UR-FBE)  
BACK P/W NO.3 Relay  
(3UR-FBE)
- \* 22:BACK P/W NO.2 Relay
- \* 23:F/PMP VSV Relay (3UR-FBE)
- \* 24:C/OPN Relay (3UR-FBE)
- \* 25:BRK NO.1 Relay

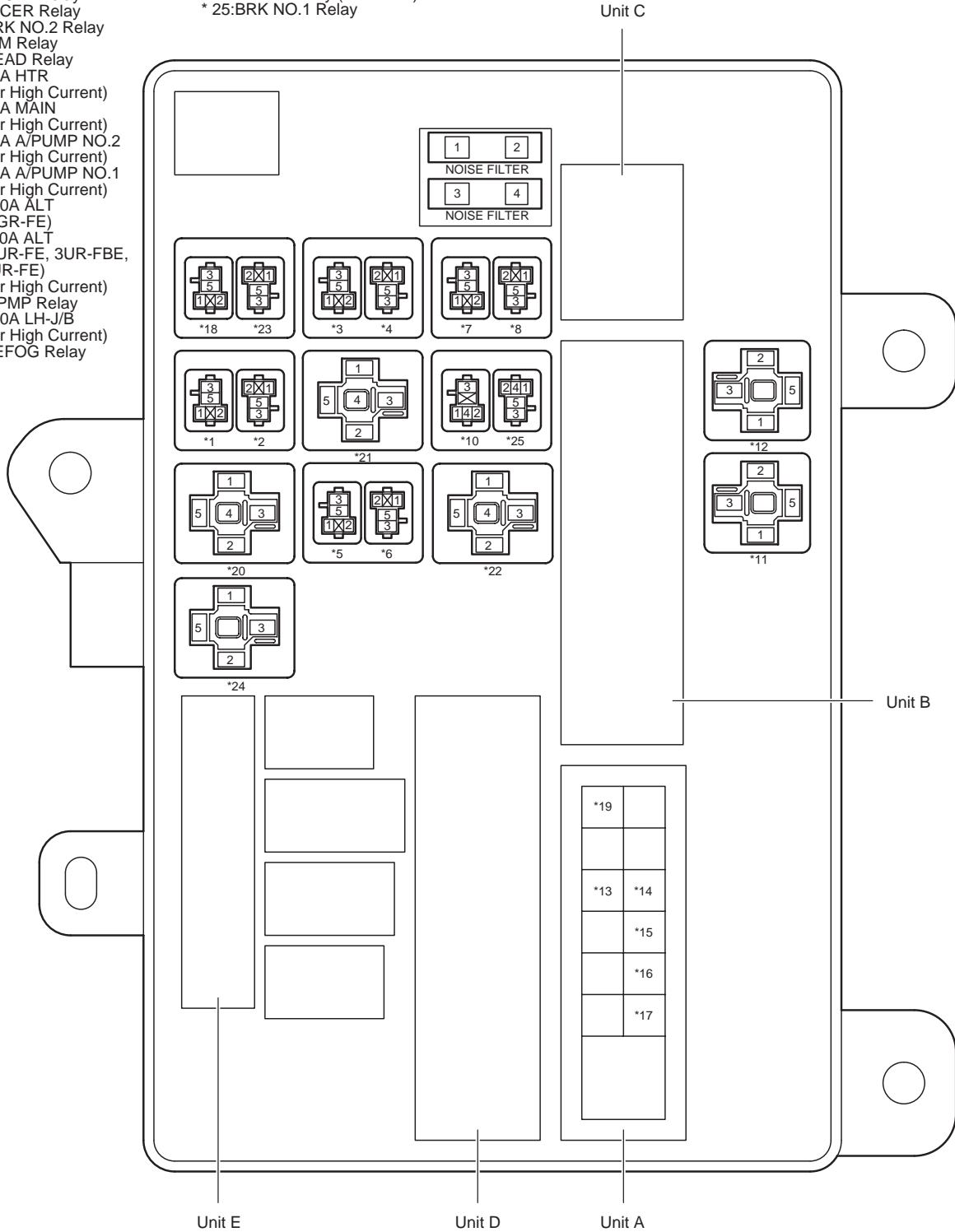

Unit A

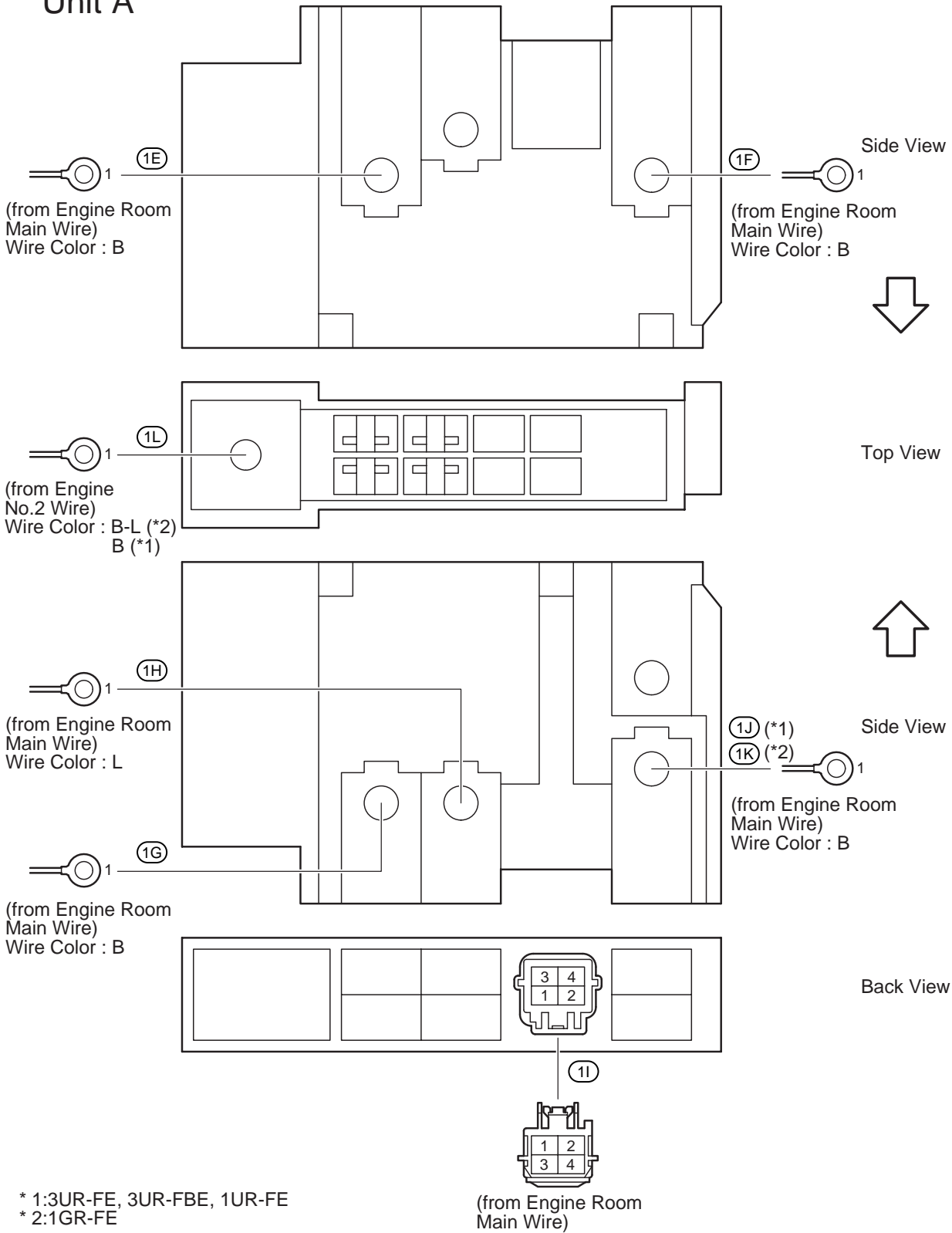

# F RELAY LOCATIONS

① : Engine Room R/B	<b>Engine Compartment Left (See Page 20)</b>
○ : Engine Room J/B	

## Unit B

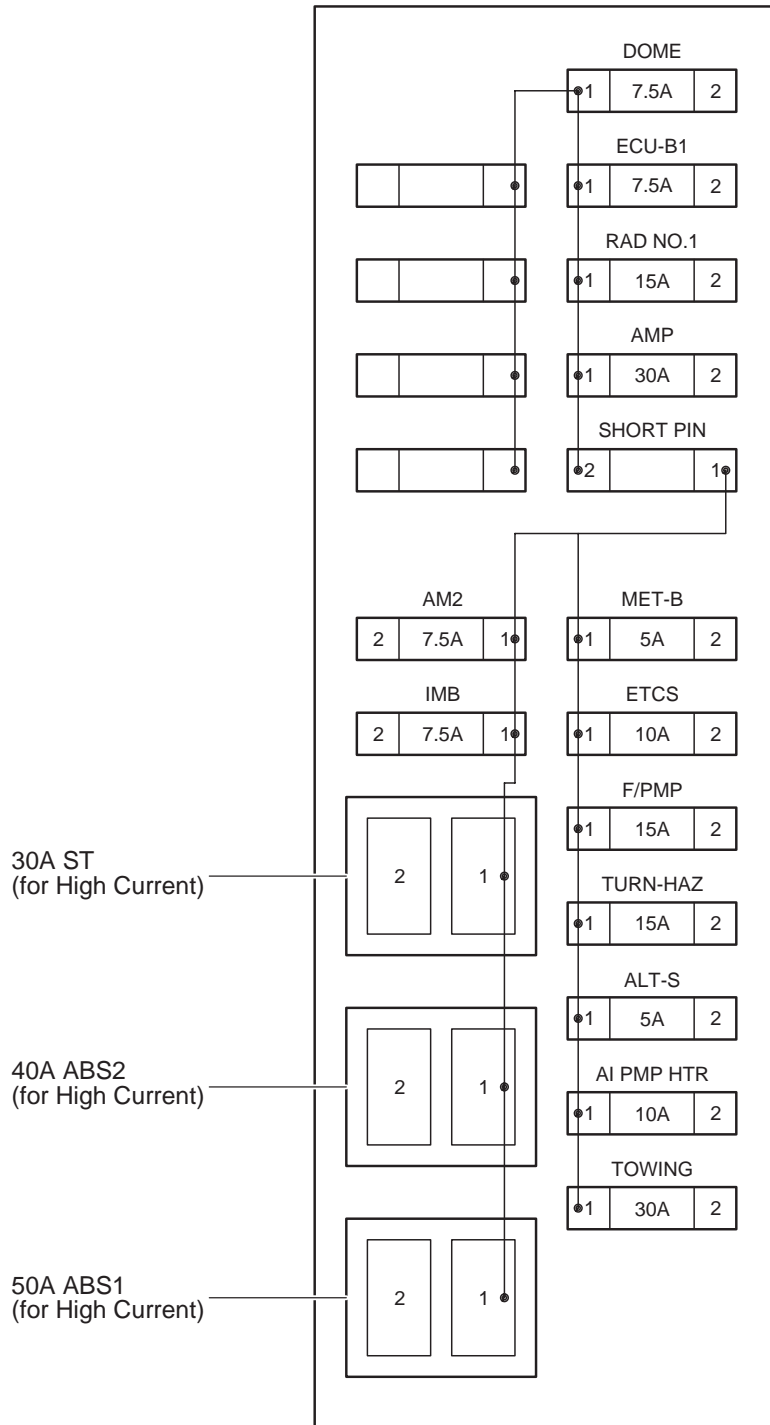

Unit C

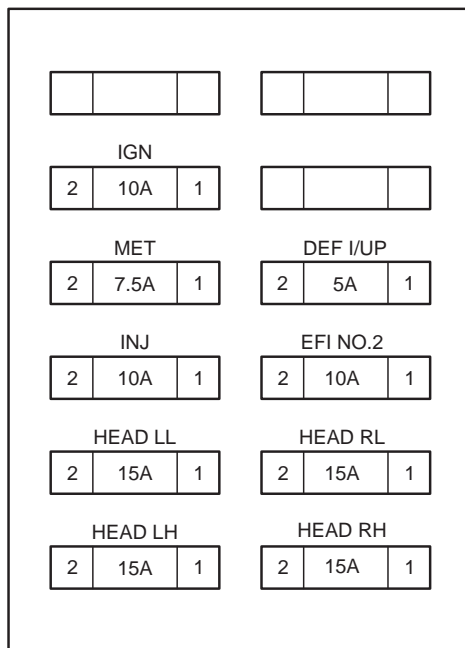



# F RELAY LOCATIONS

① : Engine Room R/B ○ : Engine Room J/B	<b>Engine Compartment Left (See Page 20)</b>
--	--

## Unit D

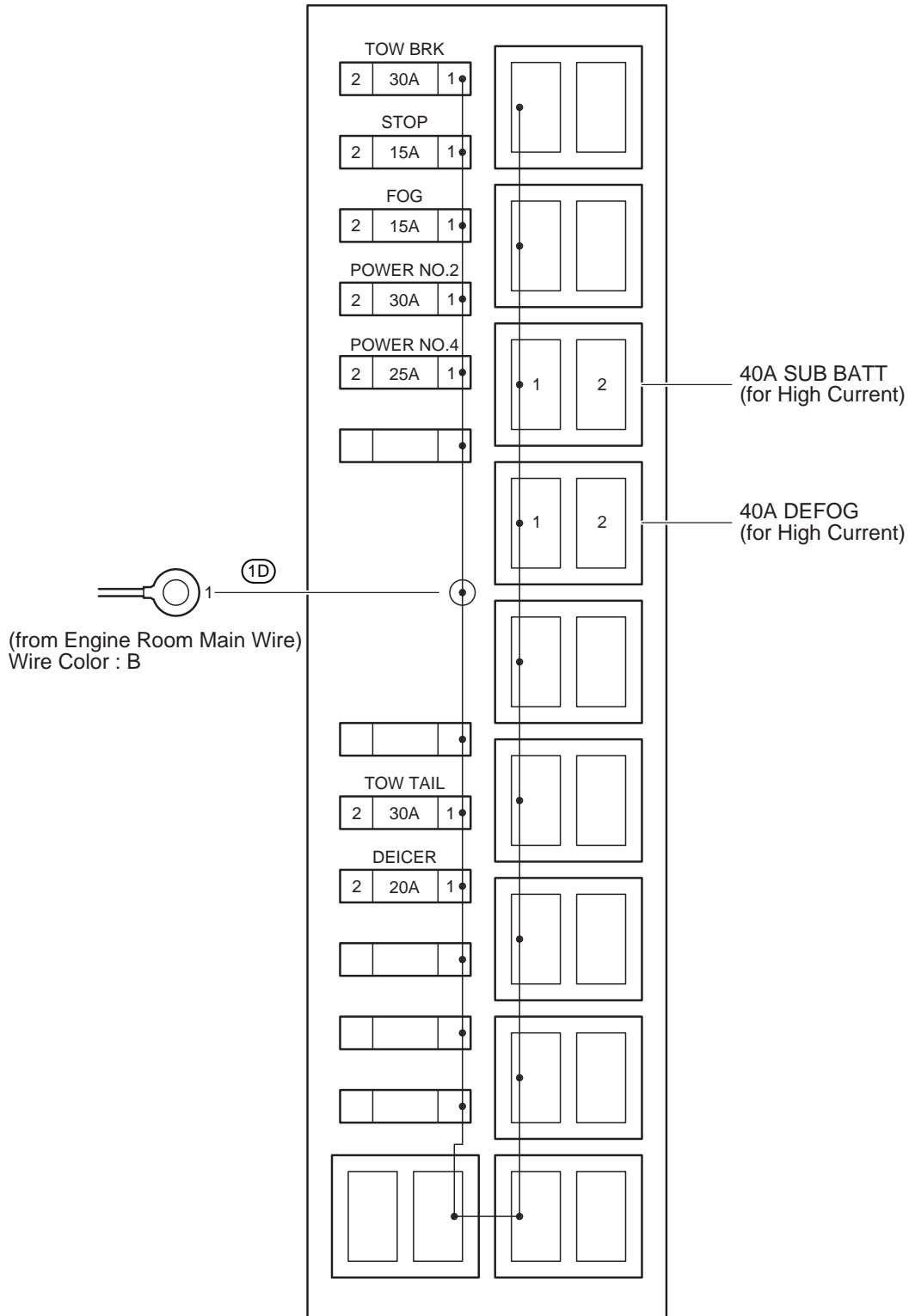

# Unit E

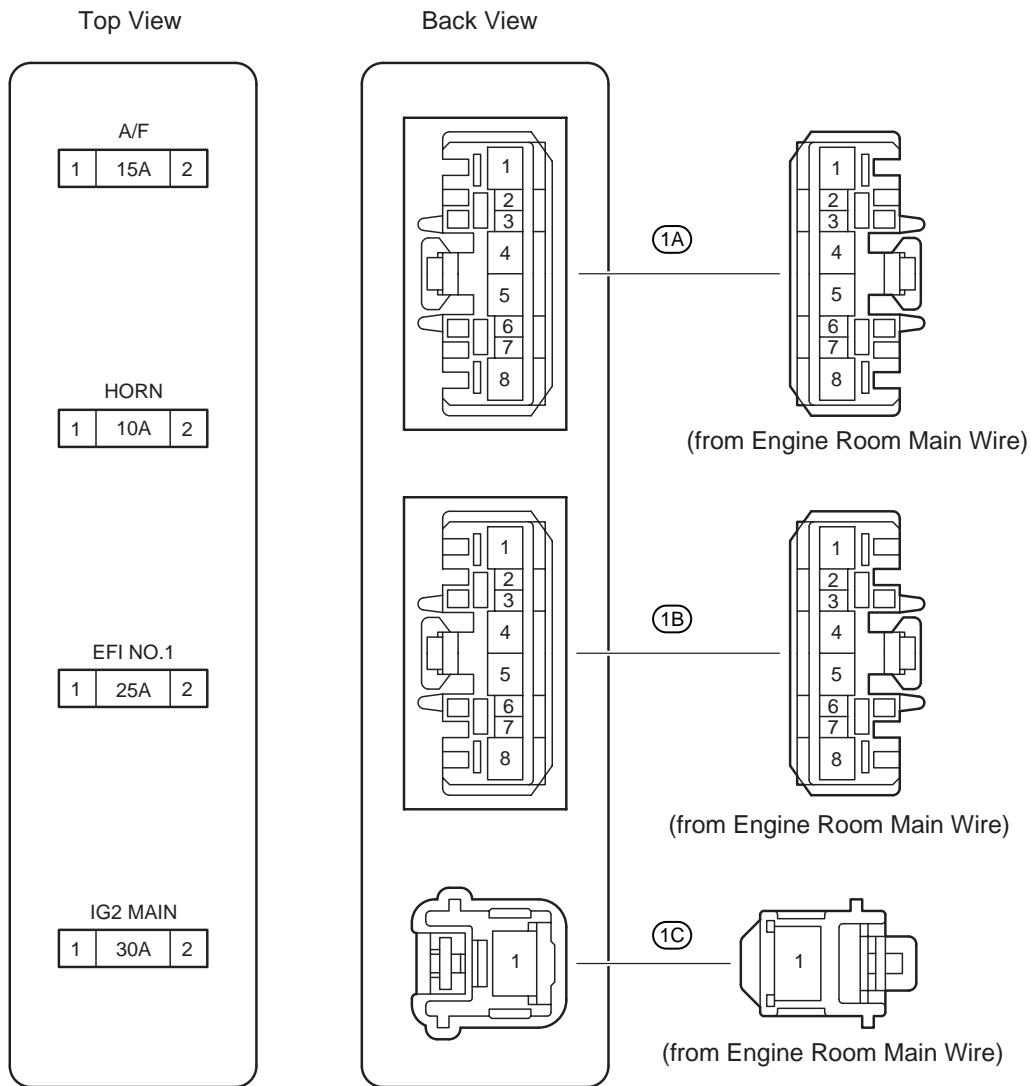

# F RELAY LOCATIONS

## [Engine Room R/B and Engine Room J/B Inner Circuit]

\* 1:3UR-FE, 3UR-FBE, 1UR-FE  
 \* 2:1GR-FE

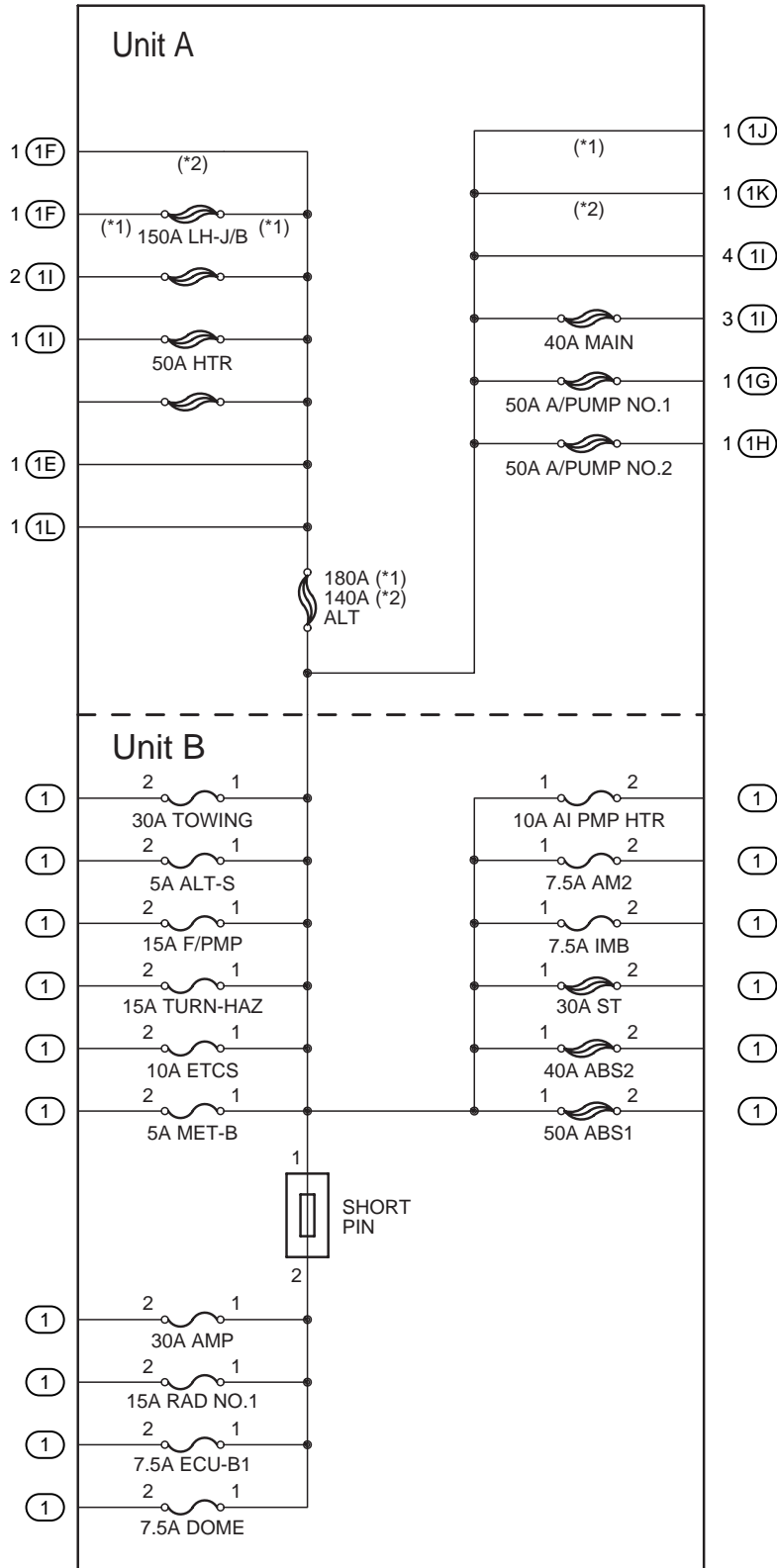

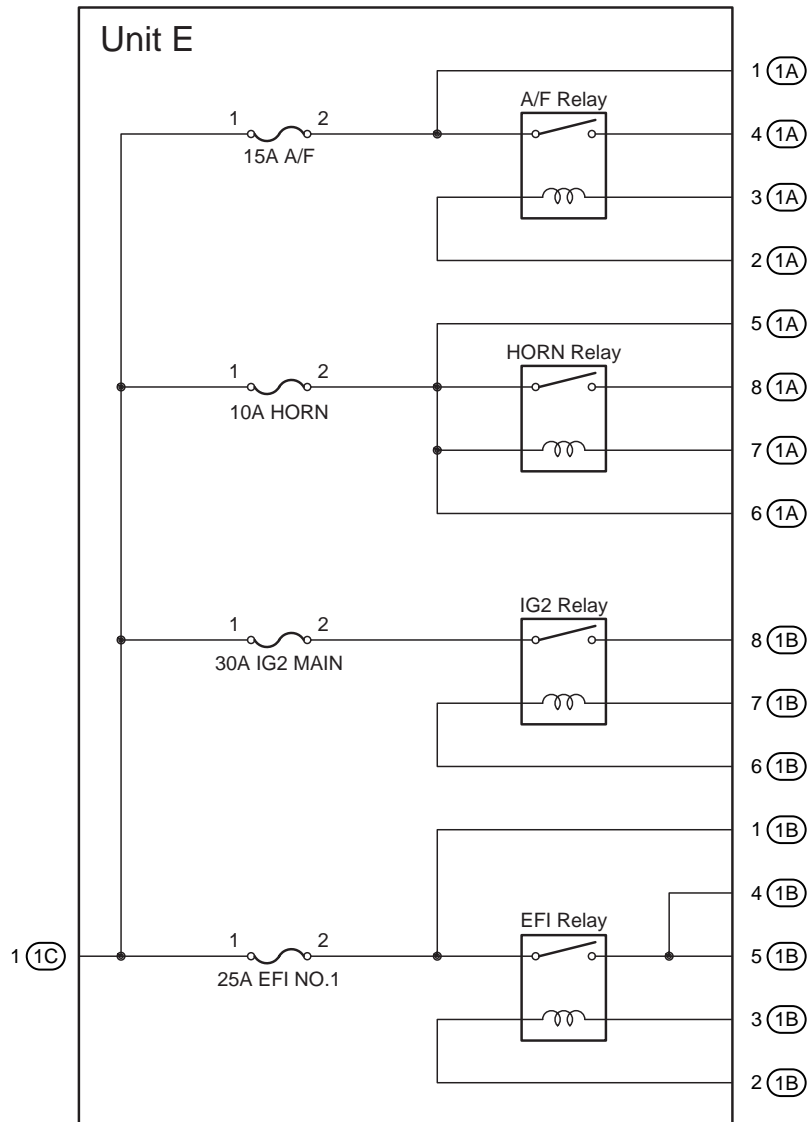

Ground Points in Instrument Panel <Column Shift>

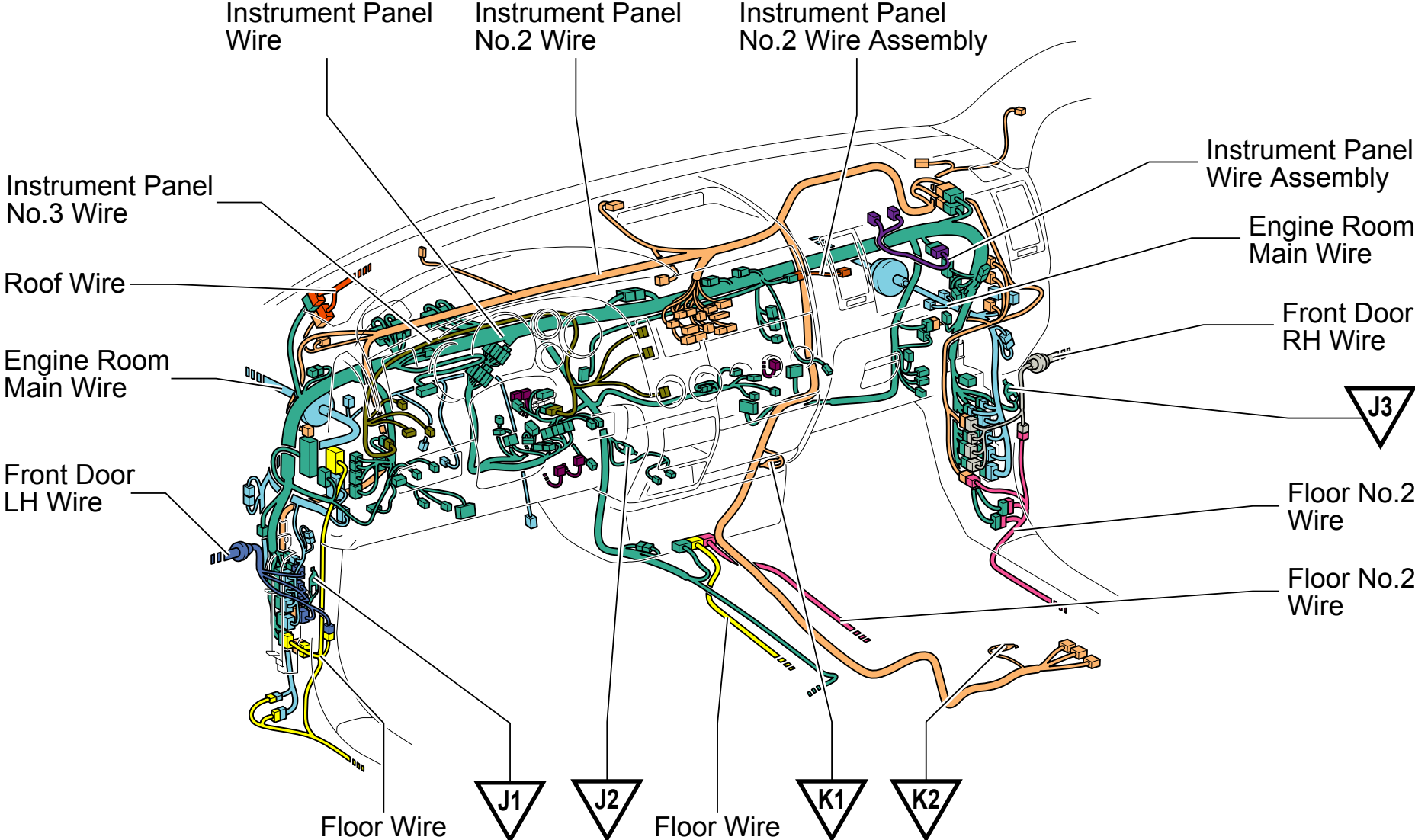

Position of Parts in Instrument Panel <Column Shift>

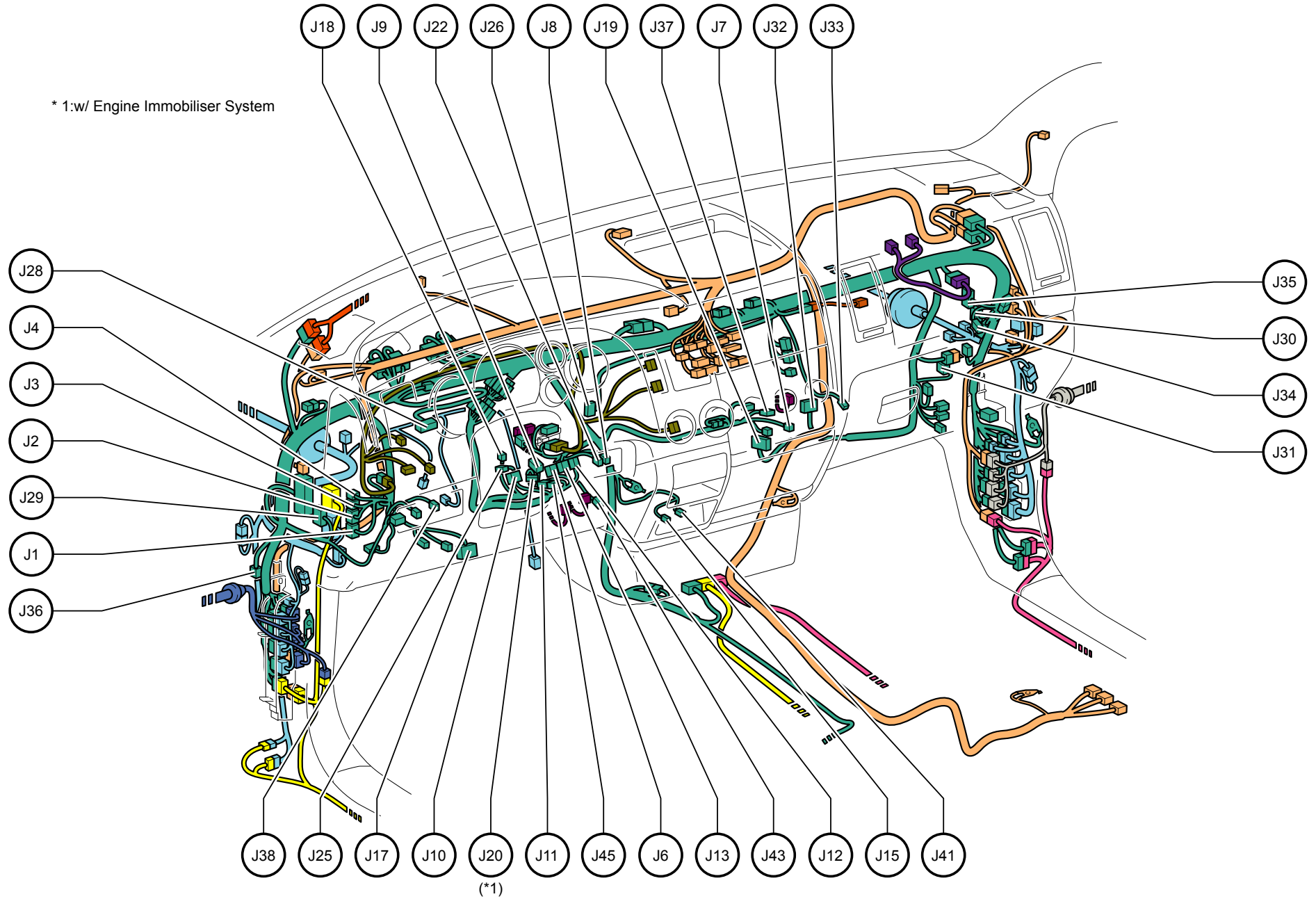

Position of Parts in Instrument Panel <Column Shift>

---

- J 1 Main Body ECU
- J 2 Main Body ECU
- J 3 Main Body ECU
- J 4 Main Body ECU
- J 6 Steering Angle Sensor
- J 7 Stereo Jack Adapter
- J 8 Power Window Regulator Switch (for Back Window)
- J 9 Ignition Switch
- J 10 Headlight Dimmer Switch Assembly
- J 11 Spiral Cable
- J 12 Windshield Wiper Switch
- J 13 Windshield Wiper Switch
- J 15 Power Outlet Socket (No.4)
- J 17 DLC3
- J 18 Unlock Warning Switch
- J 19 A/C Amplifier
- J 20 Transponder Key Amplifier
- J 22 VSC OFF Switch
- J 25 Transmission Control Switch
- J 26 Transponder Key ECU
- J 28 Combination Meter
- J 29 Flasher Relay
- J 30 Shift Lock Control ECU
- J 31 Tire Pressure Warning ECU
- J 32 Blower Motor
- J 33 Airbag Cutoff Switch
- J 34 Glove Box Illumination Light
- J 35 Clearance Sonar ECU
- J 36 Towing Brake Controller
- J 37 Integration Control and Panel Assembly
- J 38 Curtain Airbag Cutoff Switch
- J 41 Power Outlet Socket (No.1)
- J 43 Tire Pressure Warning Reset Switch
- J 45 Spiral Cable

Position of Parts in Instrument Panel <Column Shift>

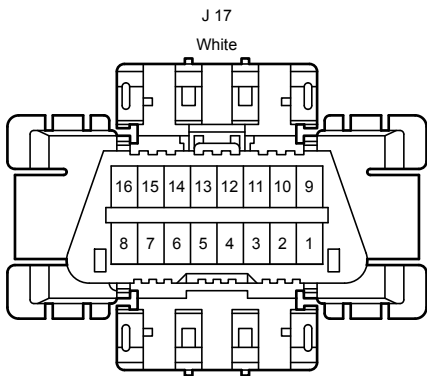
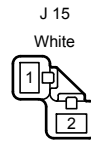
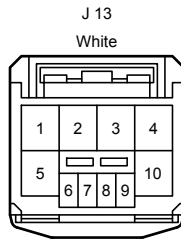
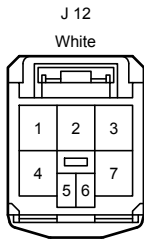
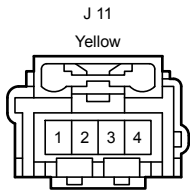
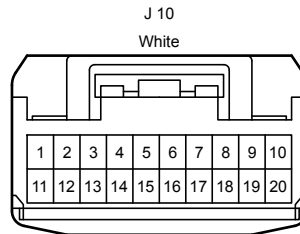
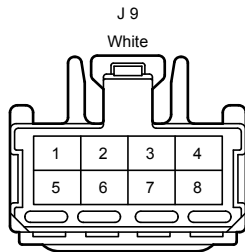
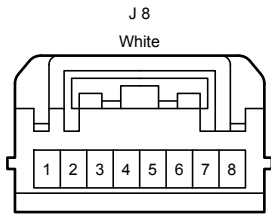
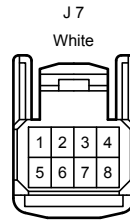
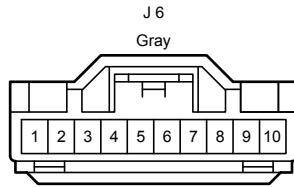
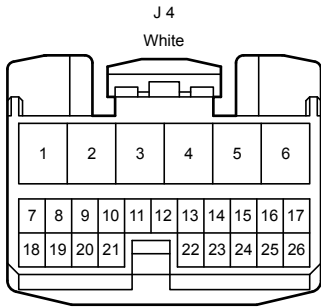
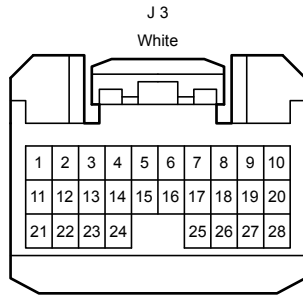
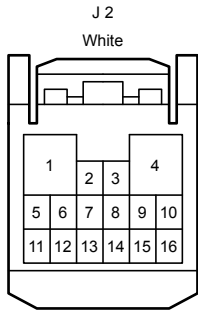
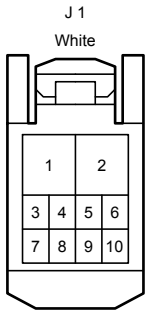



Position of Parts in Instrument Panel <Column Shift>

J 19  
White

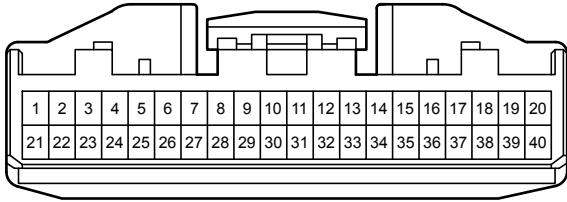

J 20  
Black

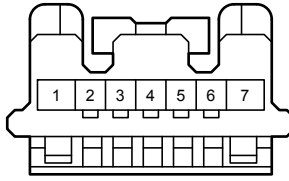

J 22  
Black

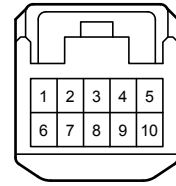

J 25  
White

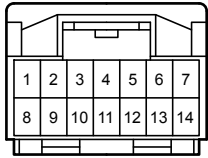

J 26  
White

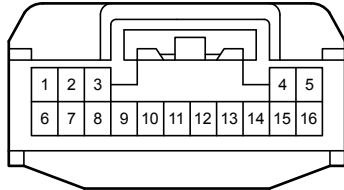

J 28  
White

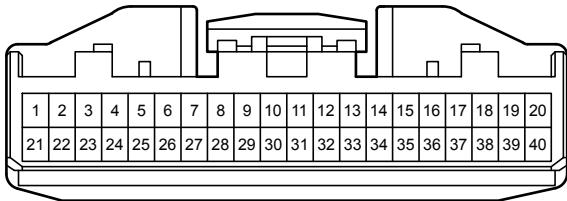

J 29  
White

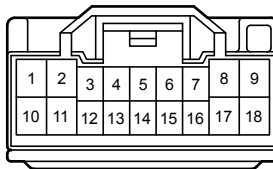

J 30  
White

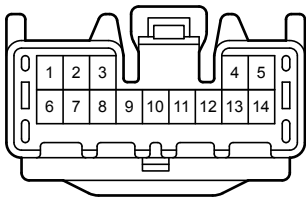

J 31  
White

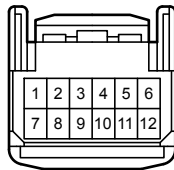

J 32  
Black

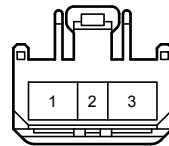

J 33  
Black



J 34  
White



J 35  
White

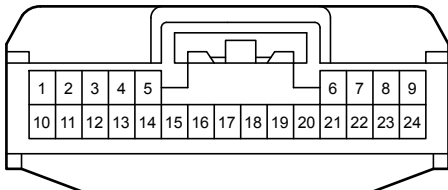

J 36  
White

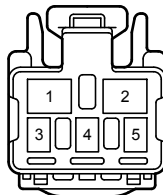

J 37  
White

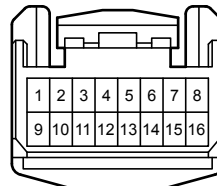

J 38  
Black

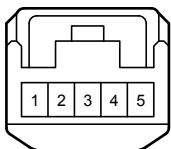

J 41  
White



J 43  
Black

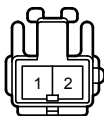

J 45  
Black

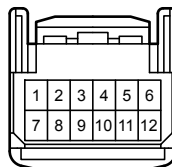

Position of Parts in Instrument Panel <Column Shift>

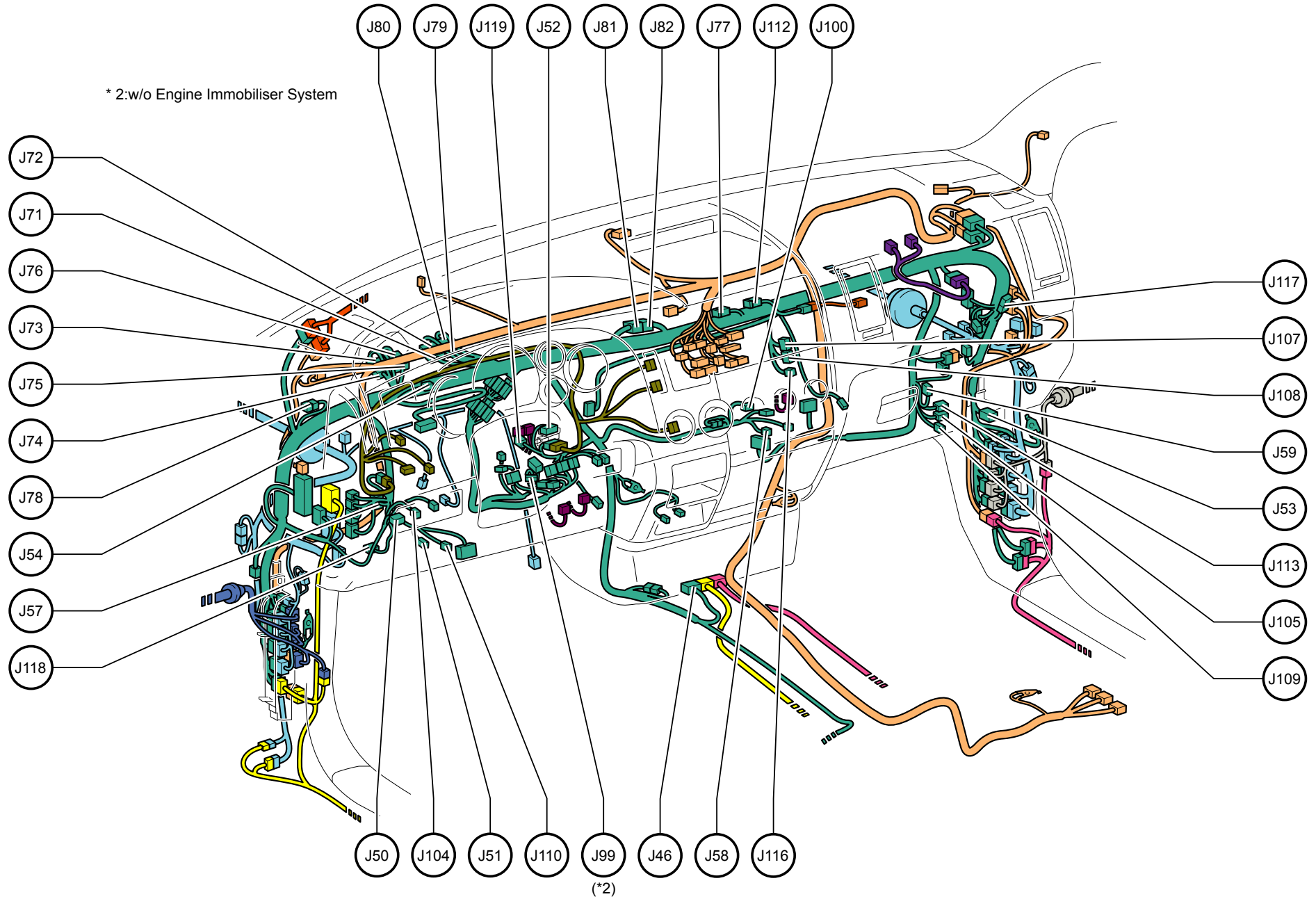

Position of Parts in Instrument Panel <Column Shift>

---

- J 46 Center Airbag ECU
- J 50 Cargo Light Switch
- J 51 Foot Light
- J 52 Back-Up Light Relay
- J 53 ACC Cut Relay
- J 54 Diode (Ignition)
- J 57 Glass Breakage Sensor ECU
- J 58 Glass Breakage Sensor Microphone
- J 59 Bus Buffer
- J 71 Junction Connector
- J 72 Junction Connector
- J 73 Junction Connector
- J 74 Junction Connector
- J 75 Junction Connector
- J 76 Junction Connector
- J 77 Junction Connector
- J 78 Junction Connector
- J 79 Junction Connector
- J 80 Junction Connector
- J 81 Junction Connector
- J 82 Junction Connector
- J 99 Ignition Key Cylinder Light
- J 100 Stereo Jack Adapter Assembly
- J 104 Headlight Levering Switch
- J 105 Back Up Light Relay
- J 107 Multi-Media Interface ECU
- J 108 Multi-Media Interface ECU
- J 109 No.1 Instrument Panel Airbag Assembly Lower RH
- J 110 No.1 Instrument Panel Airbag Assembly Lower LH
- J 112 Junction Connector
- J 113 Junction Connector
- J 116 Multi-Media Interface ECU
- J 117 Junction Connector
- J 118 Junction Connector
- J 119 Power Steering ECU Assembly

Position of Parts in Instrument Panel <Column Shift>

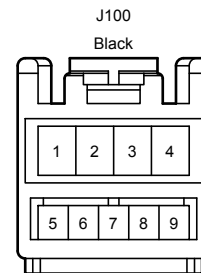
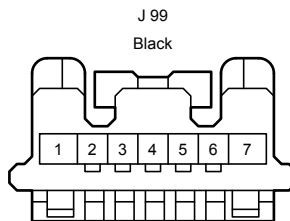
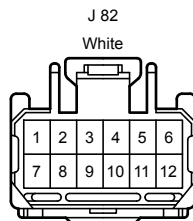
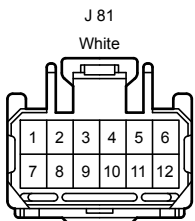
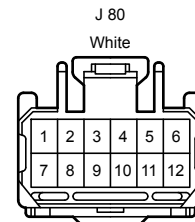
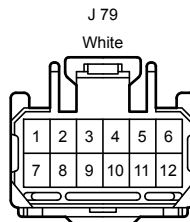
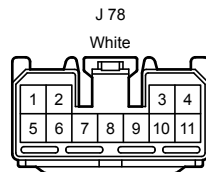
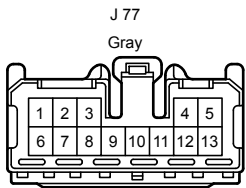
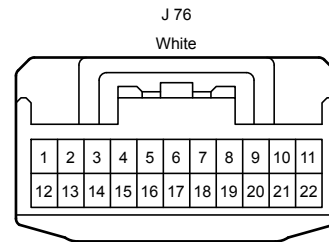
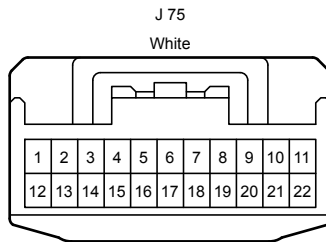
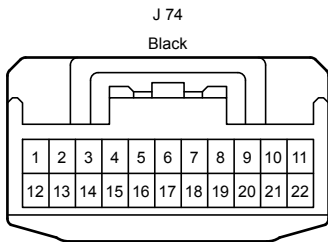
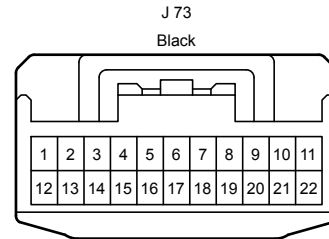
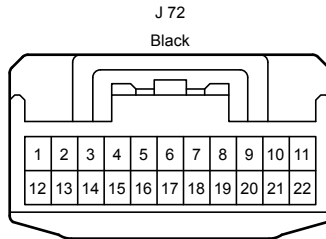
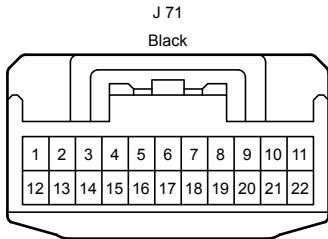
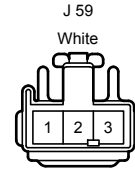
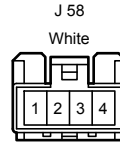
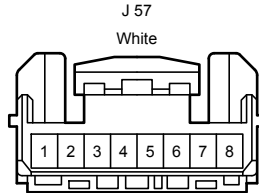
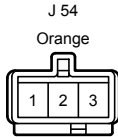
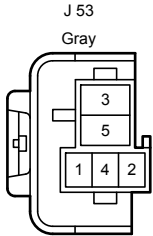
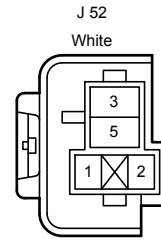
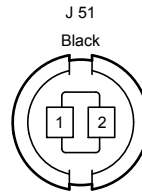
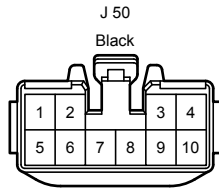
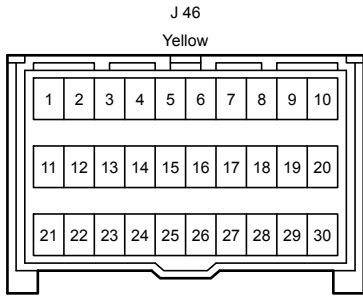

Position of Parts in Instrument Panel <Column Shift>

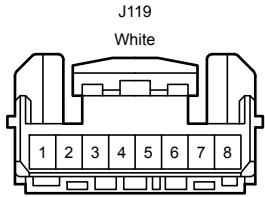
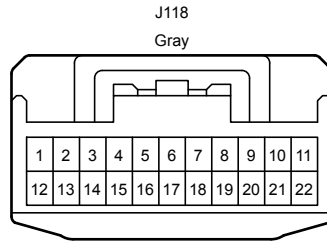
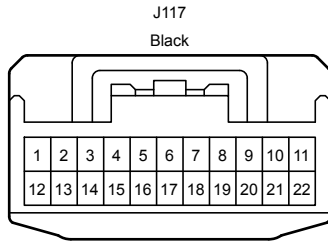
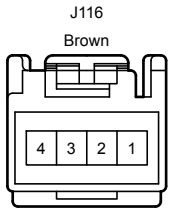
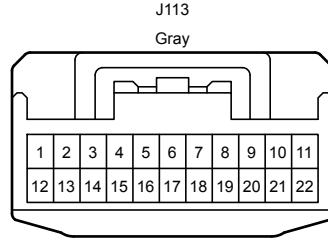
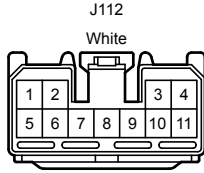
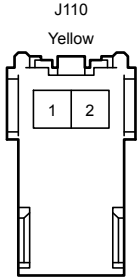
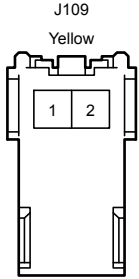
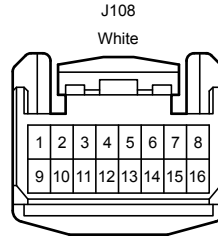
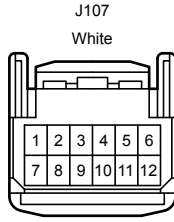
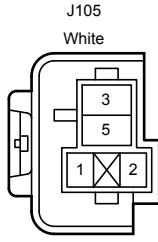
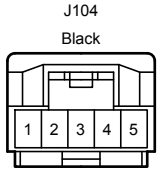

Position of Parts in Instrument Panel <Column Shift>

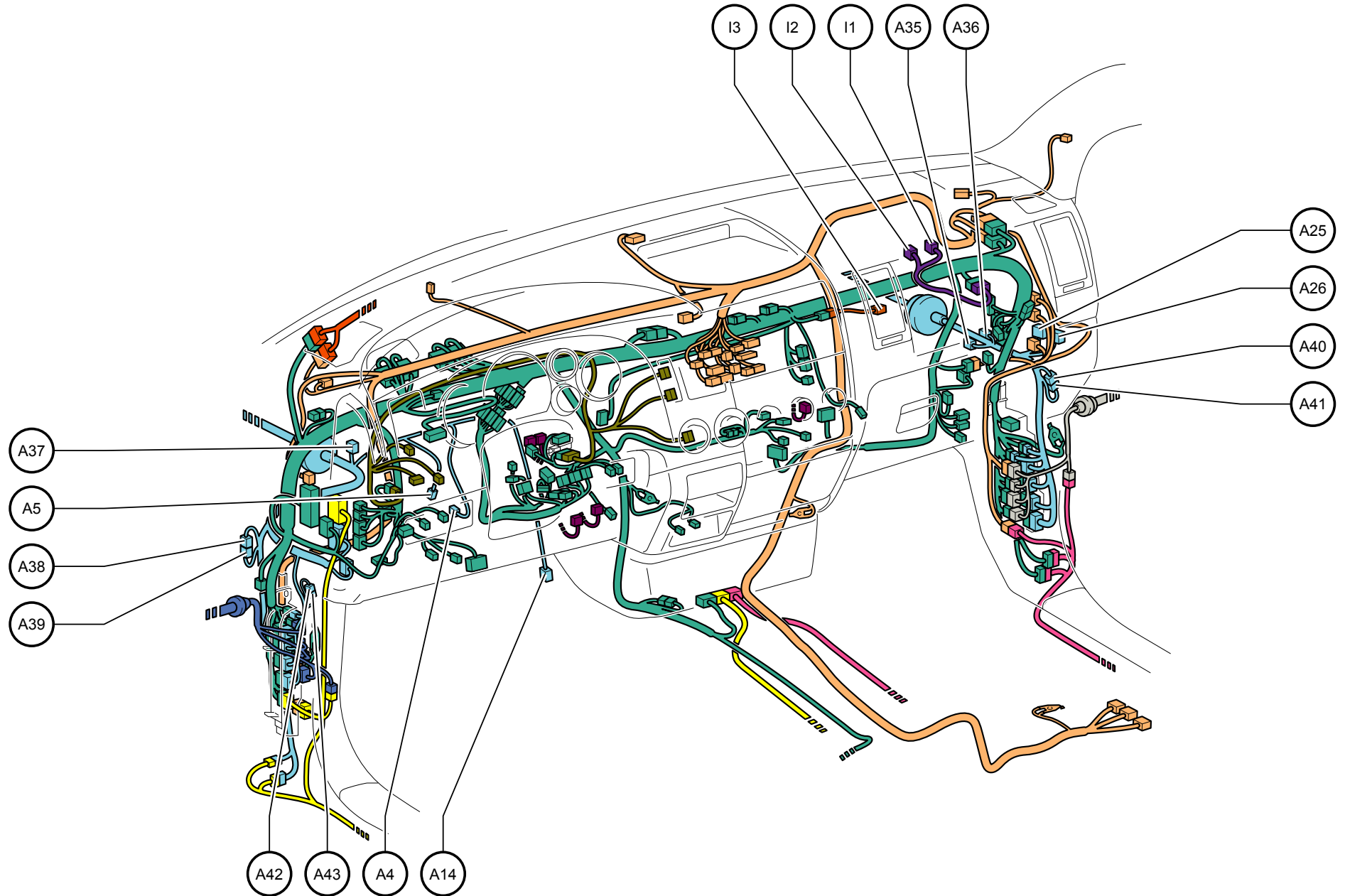

Position of Parts in Instrument Panel <Column Shift>

---

- A 4 Stop Light Switch
- A 5 Parking Brake Switch
- A 14 Accelerator Position Sensor
- A 25 4WD Control ECU
- A 26 4WD Control ECU
- A 35 Diode (Starting)
- A 36 Junction Connector
- A 37 Junction Connector
- A 38 Junction Connector
- A 39 Junction Connector
- A 40 Junction Connector
- A 41 Junction Connector
- A 42 Junction Connector
- A 43 Junction Connector
  
- I 1 Front Passenger Side Squib Circuit
- I 2 Front Passenger Side Squib Circuit
- I 3 Front Passenger Side Squib Circuit

Position of Parts in Instrument Panel <Column Shift>

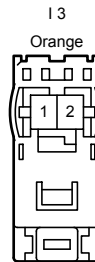
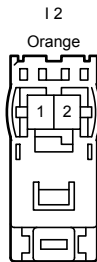
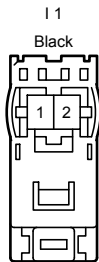
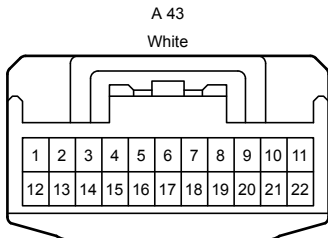
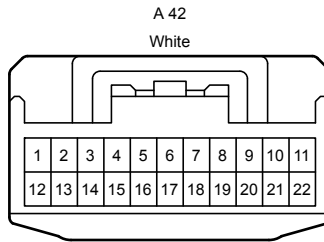
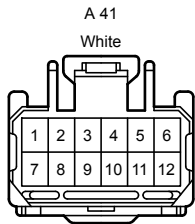
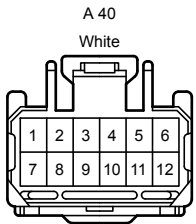
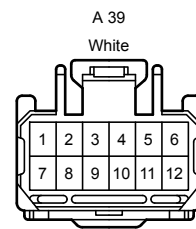
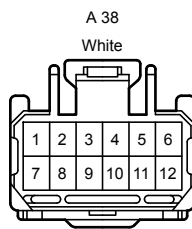
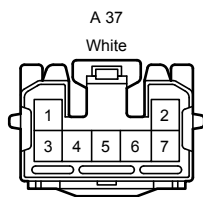
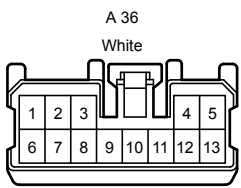
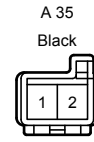
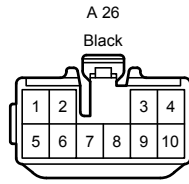
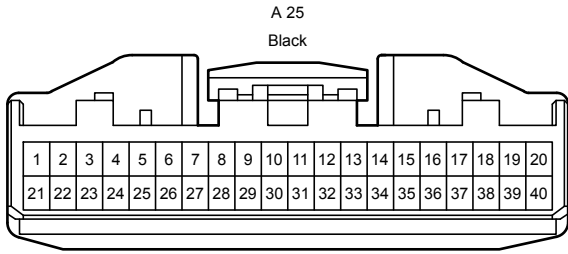
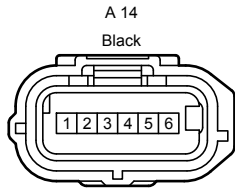
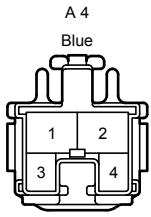



Position of Parts in Instrument Panel <Column Shift>

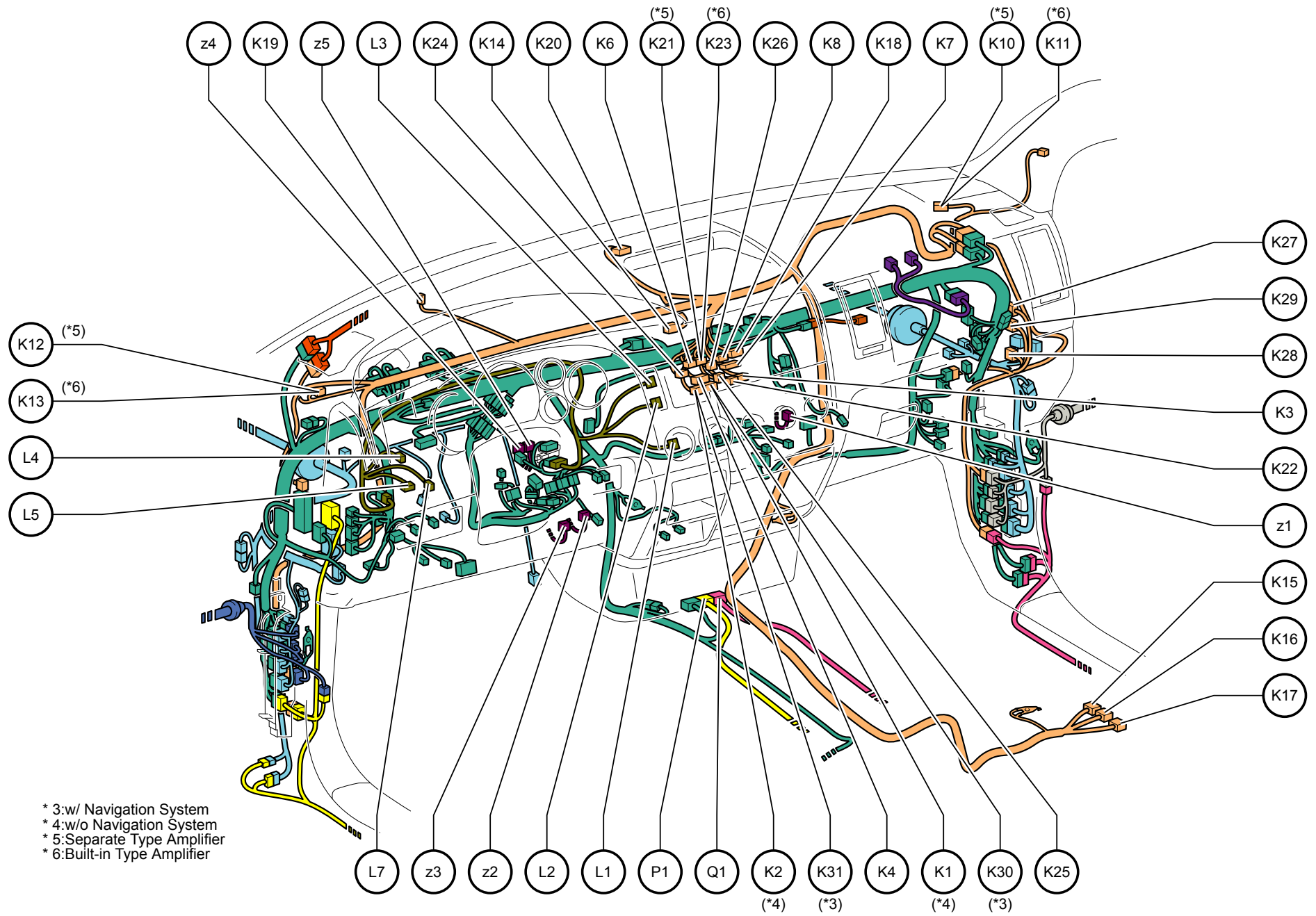

Position of Parts in Instrument Panel <Column Shift>

---

- K 1 Radio Receiver Assembly
- K 2 Radio Receiver Assembly
- K 3 Radio Receiver Assembly
- K 4 Radio Receiver Assembly
- K 6 Navigation Receiver Assembly
- K 7 Navigation Receiver Assembly
- K 8 Navigation Receiver Assembly
- K 10 Front Side Speaker RH
- K 11 Front Side Speaker RH
- K 12 Front Side Speaker LH
- K 13 Front Side Speaker LH
- K 14 Center Speaker
- K 15 Stereo Component Amplifier
- K 16 Stereo Component Amplifier
- K 17 Stereo Component Amplifier
- K 18 Navigation Receiver Assembly
- K 19 Light Control Sensor
- K 20 Accessory Meter Assembly
- K 21 Navigation Receiver Assembly
- K 22 Radio Receiver Assembly
- K 23 Navigation Receiver Assembly
- K 24 Navigation Receiver Assembly
- K 25 Radio Receiver Assembly
- K 26 Navigation Receiver Assembly
- K 27 Stereo Component Tuner Assembly
- K 28 Stereo Component Tuner Assembly
- K 29 Stereo Component Tuner Assembly
- K 30 Navigation Receiver Assembly
- K 31 Navigation Receiver Assembly
  
- L 1 4WD Control Switch
- L 2 Drive Monitor Switch
- L 3 Hazard Warning Signal Switch
- L 4 Light Control Rheostat
- L 5 Outer Mirror Switch
- L 7 Room Lamp Switch
  
- P 1 Center Airbag ECU
  
- Q 1 Center Airbag ECU
  
- z 1 A/C Amplifier , A/C Blower Assembly
- z 2 Spiral Cable , Cruise Control Main Switch
- z 3 Spiral Cable , Steering Pad Switch
- z 4 Spiral Cable , Driver Side Squib Circuit
- z 5 Spiral Cable , Driver Side Squib 2nd Step Circuit

Position of Parts in Instrument Panel <Column Shift>

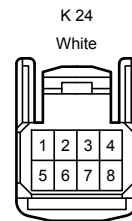
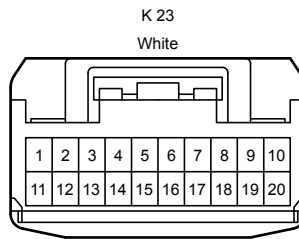
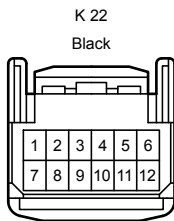
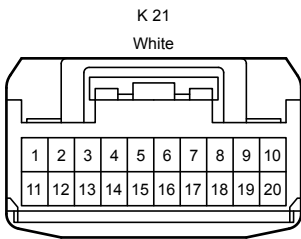
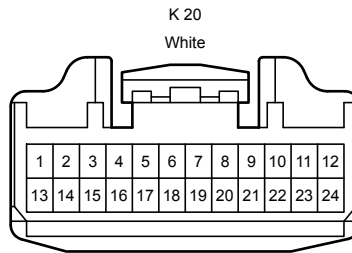
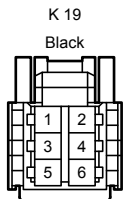
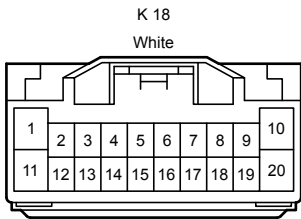
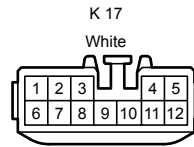
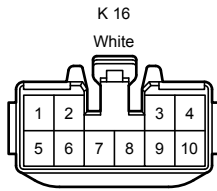
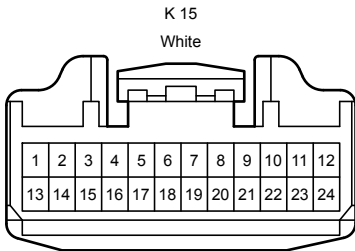
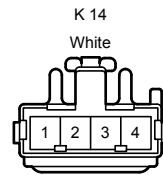
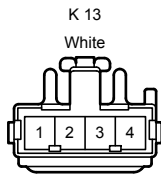
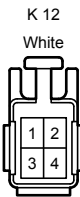
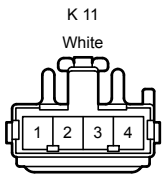
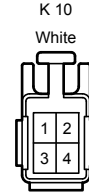
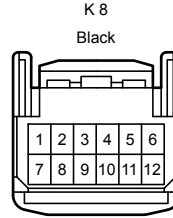
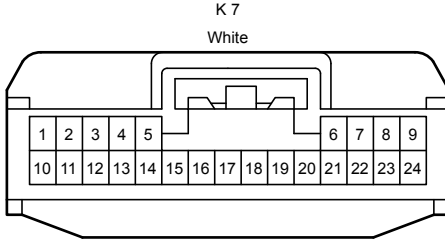
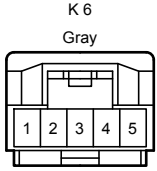
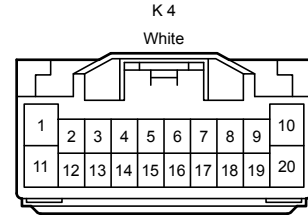
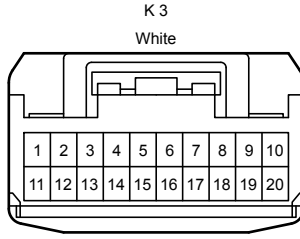
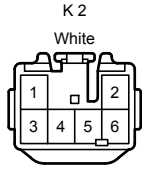
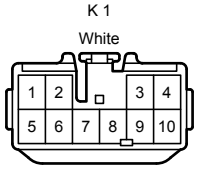

Position of Parts in Instrument Panel <Column Shift>

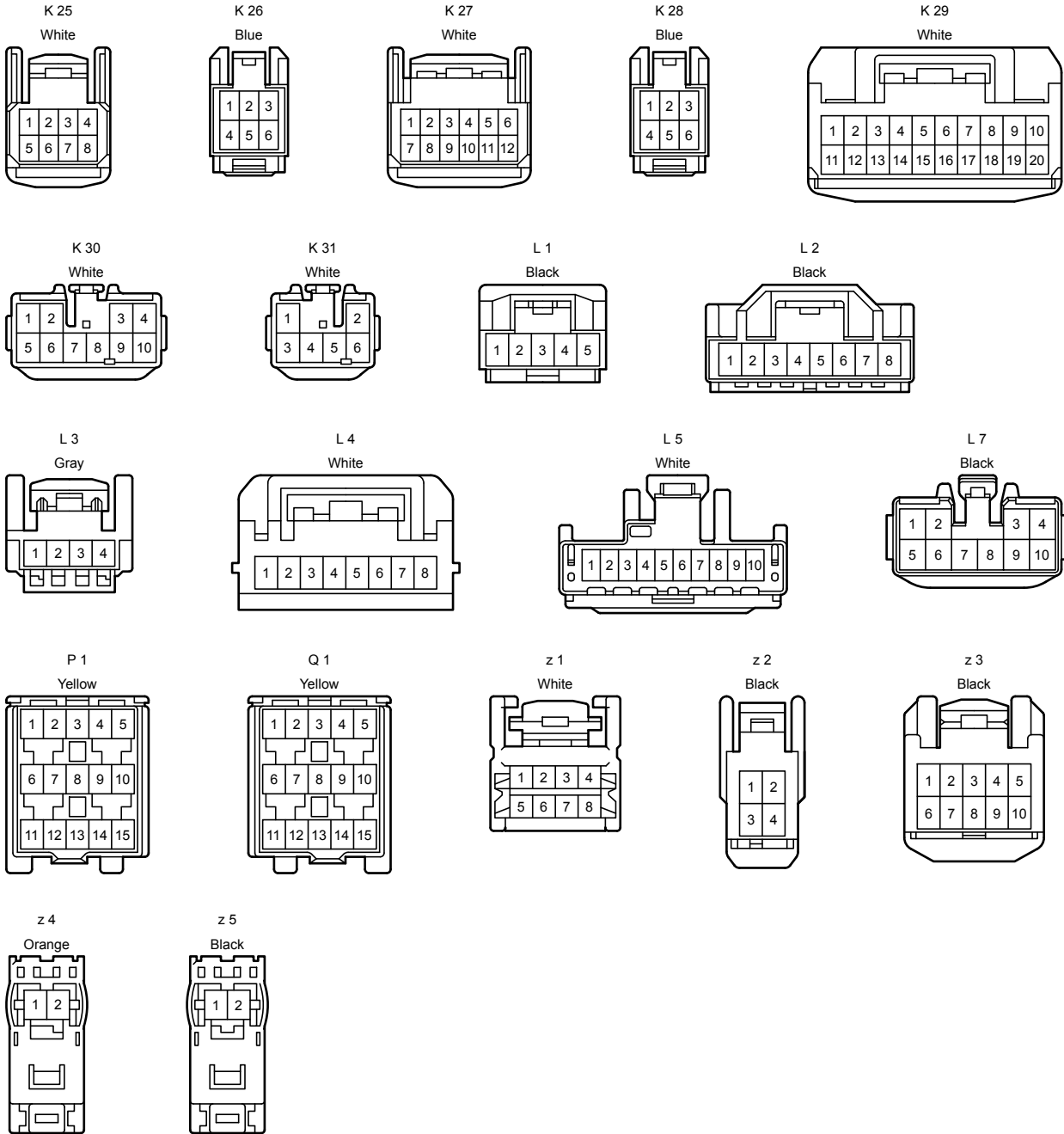

**[Instrument Panel]  
(Floor Shift)**

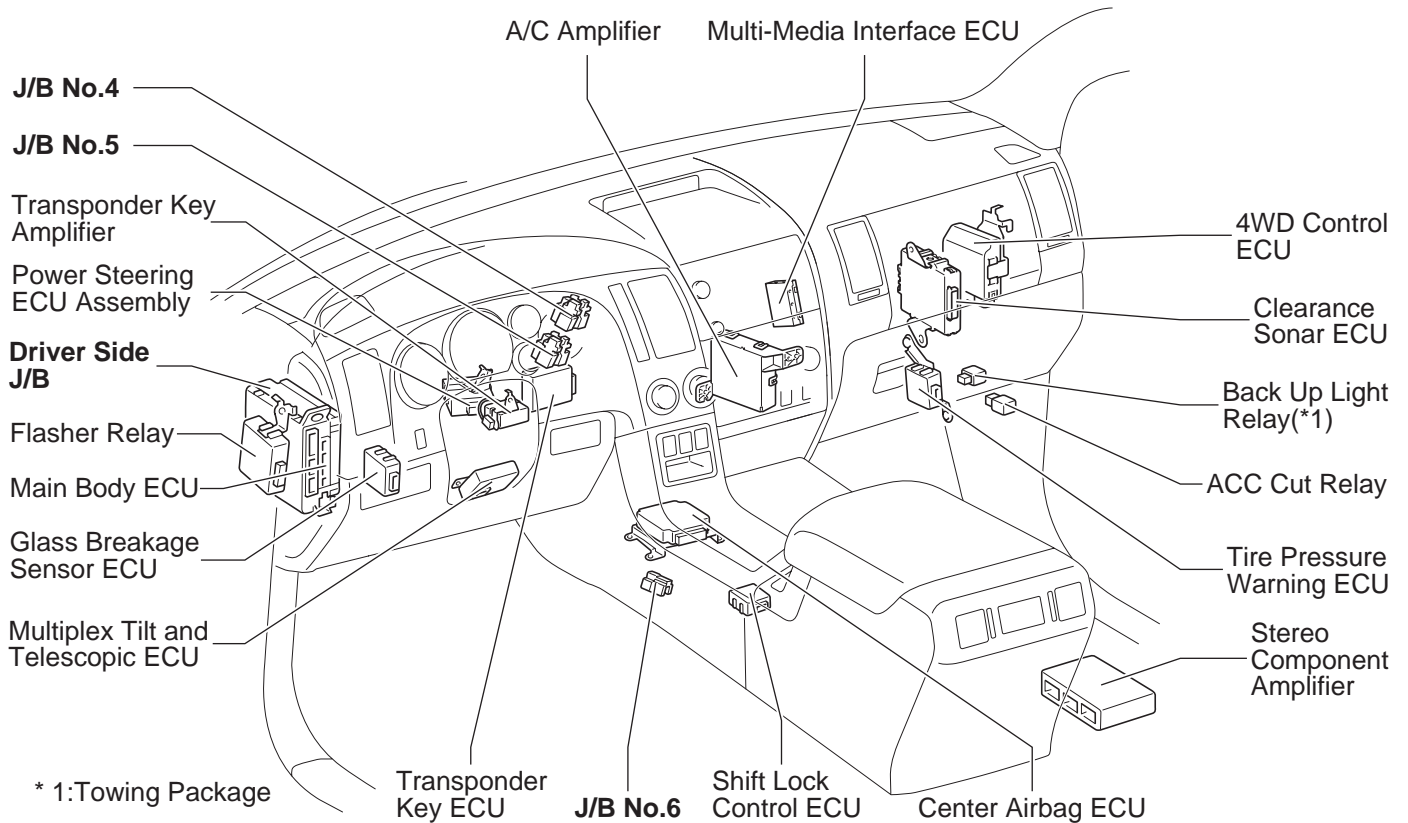

**(Column Shift)**

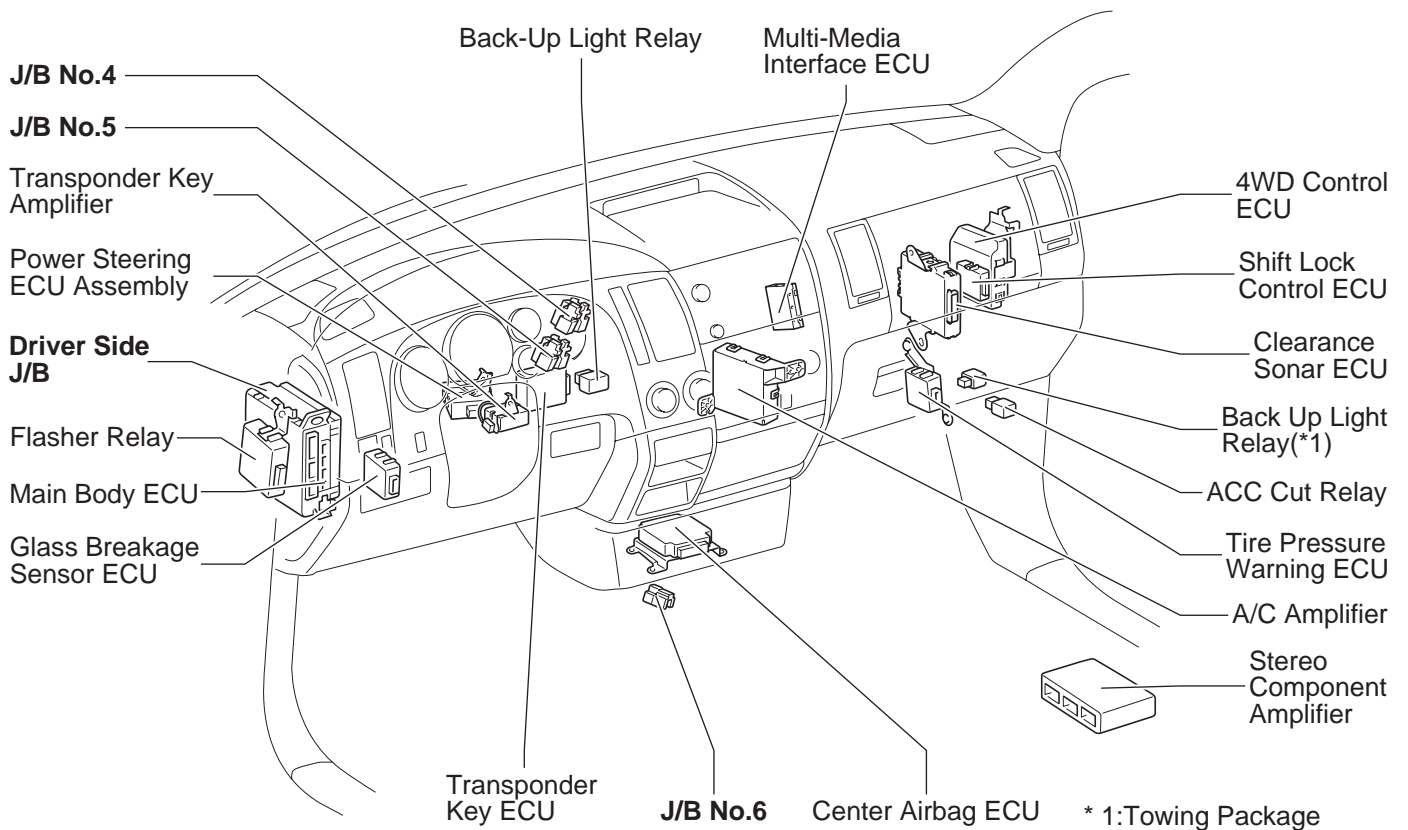

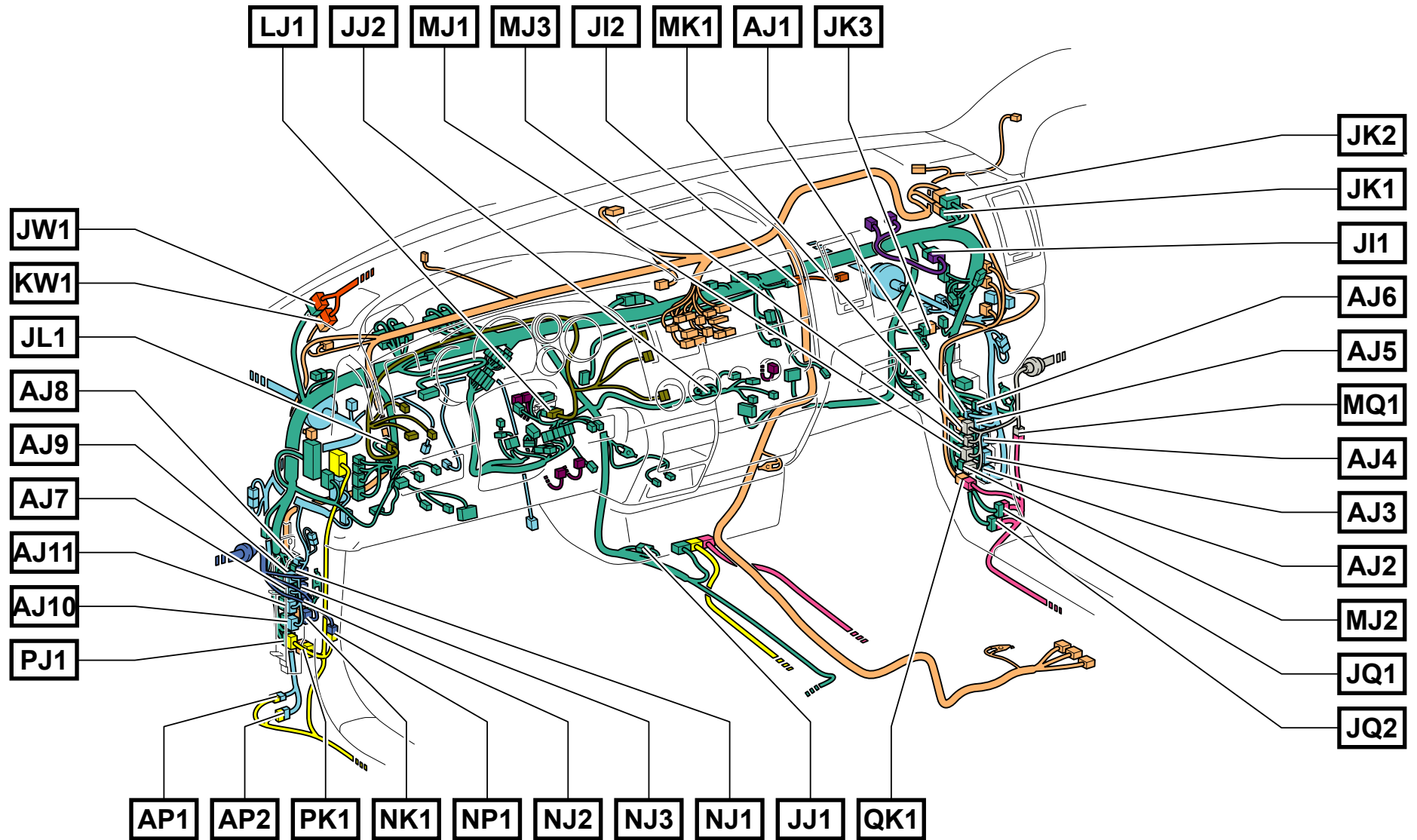

Wire and Wire in Instrument Panel <Column Shift>

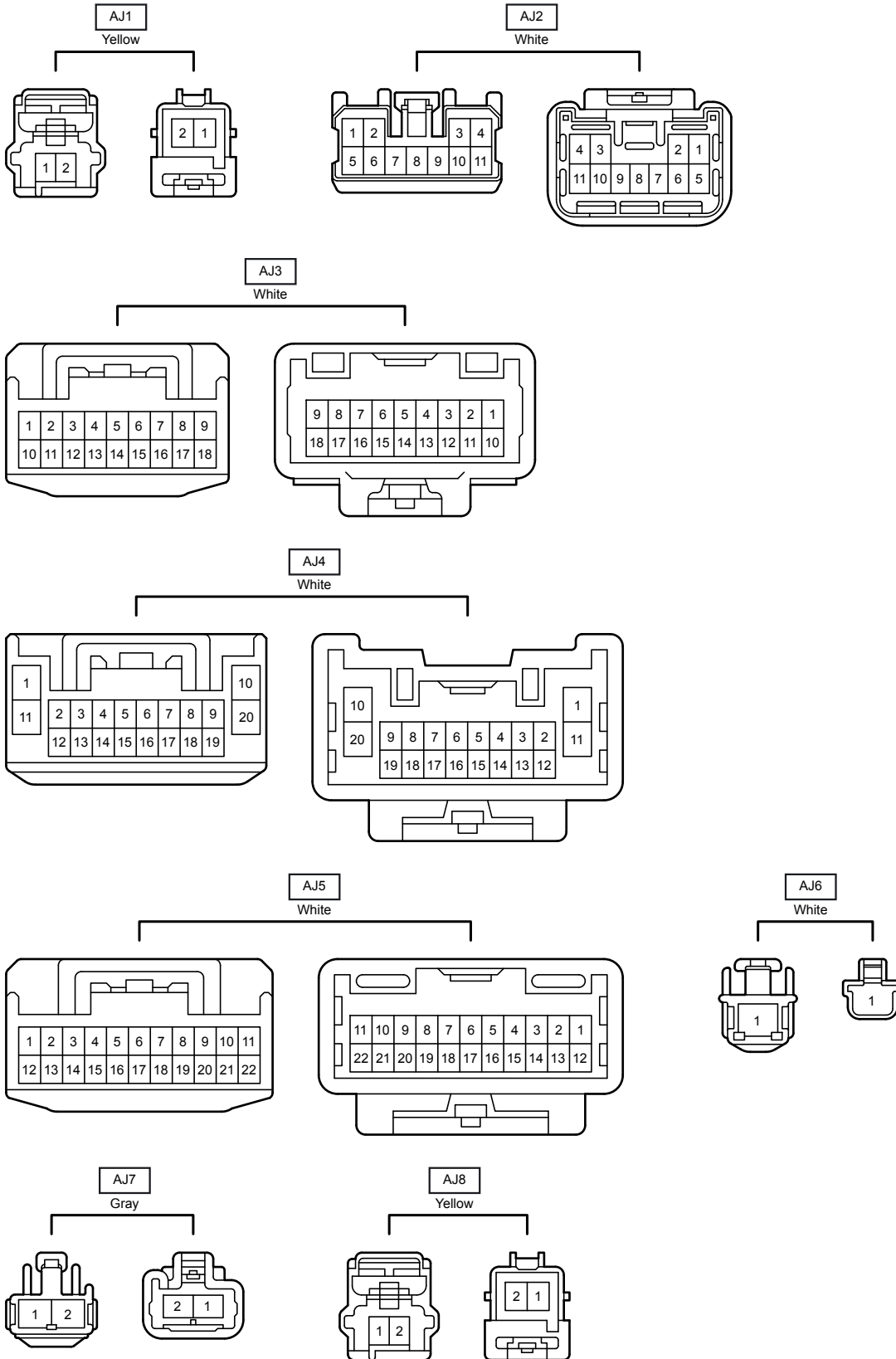

Wire and Wire in Instrument Panel <Column Shift>

AJ9  
Gray

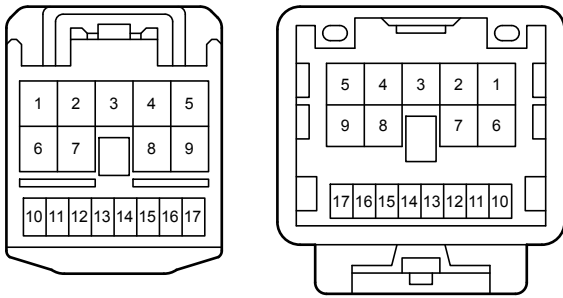

AJ10  
Gray

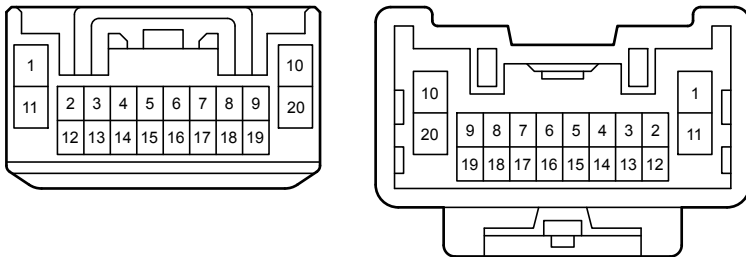

AJ11  
Gray

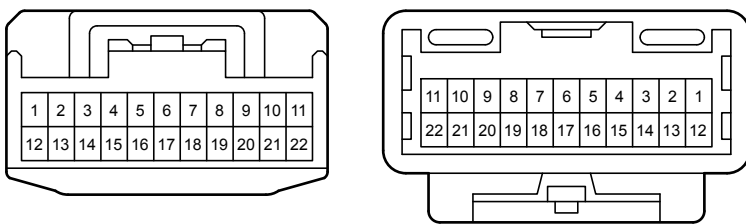

AP1  
White

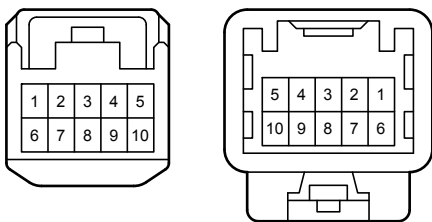

AP2  
White

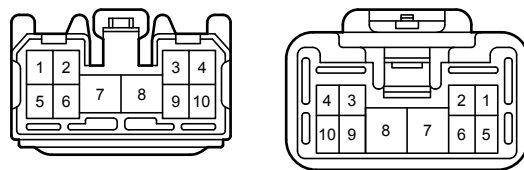

J11  
Yellow

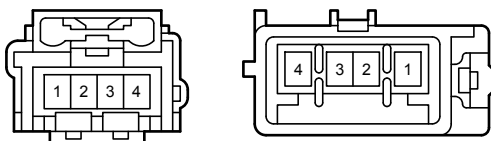

J12

Yellow Orange

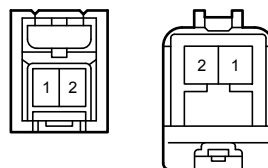



Wire and Wire in Instrument Panel <Column Shift>

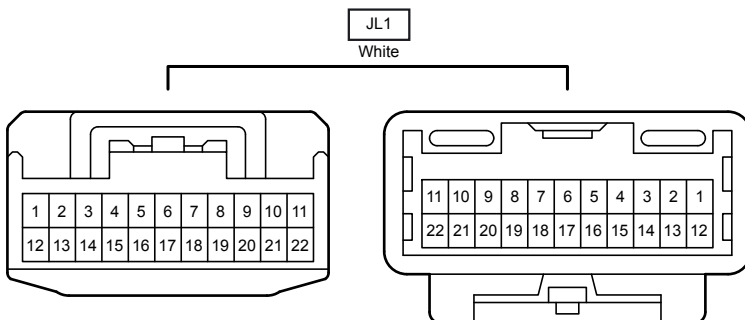
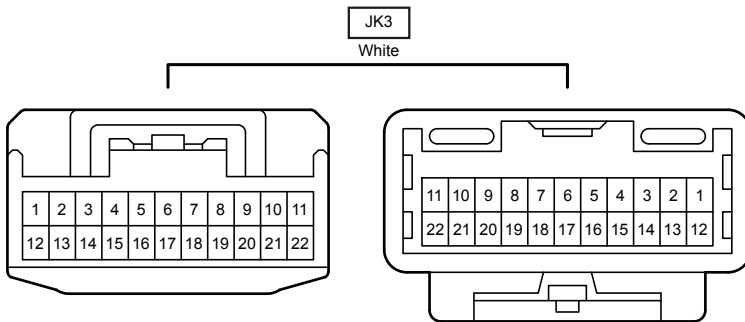
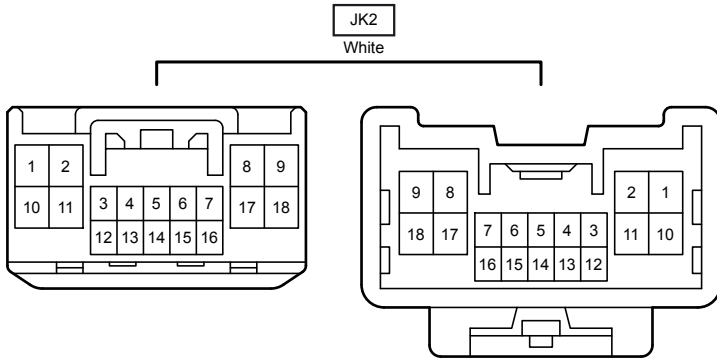
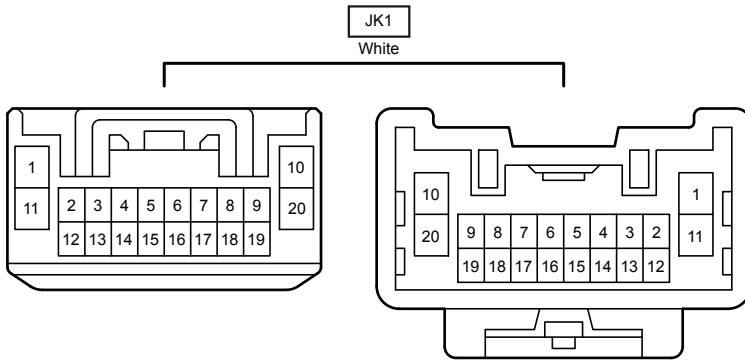
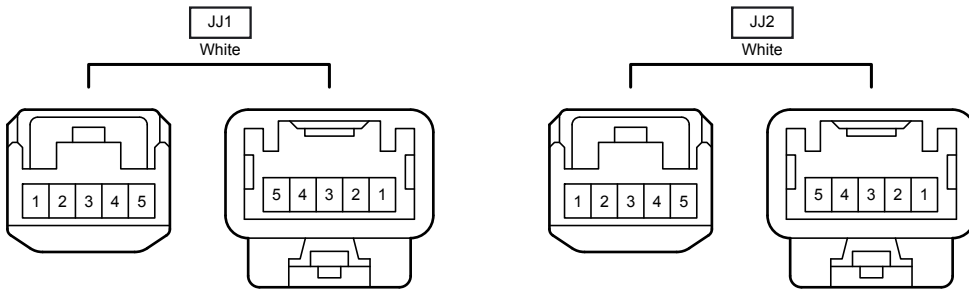

JQ1  
Gray

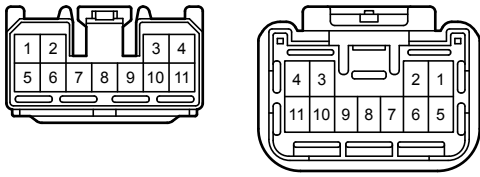

JQ2  
Gray

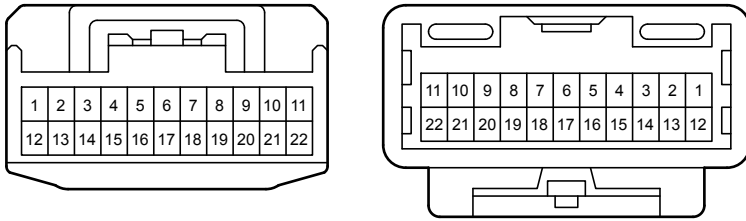

JW1  
White

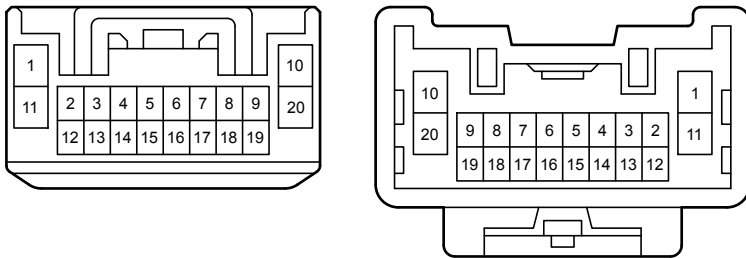

KW1  
White

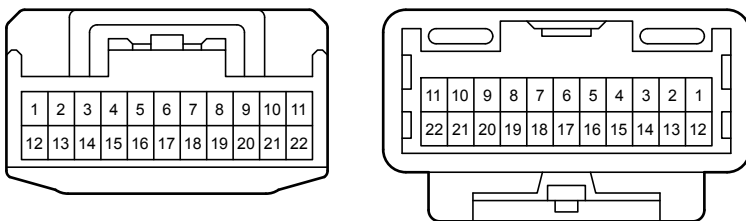

LJ1  
White

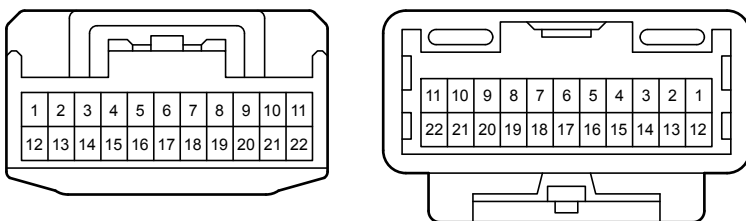

Wire and Wire in Instrument Panel <Column Shift>

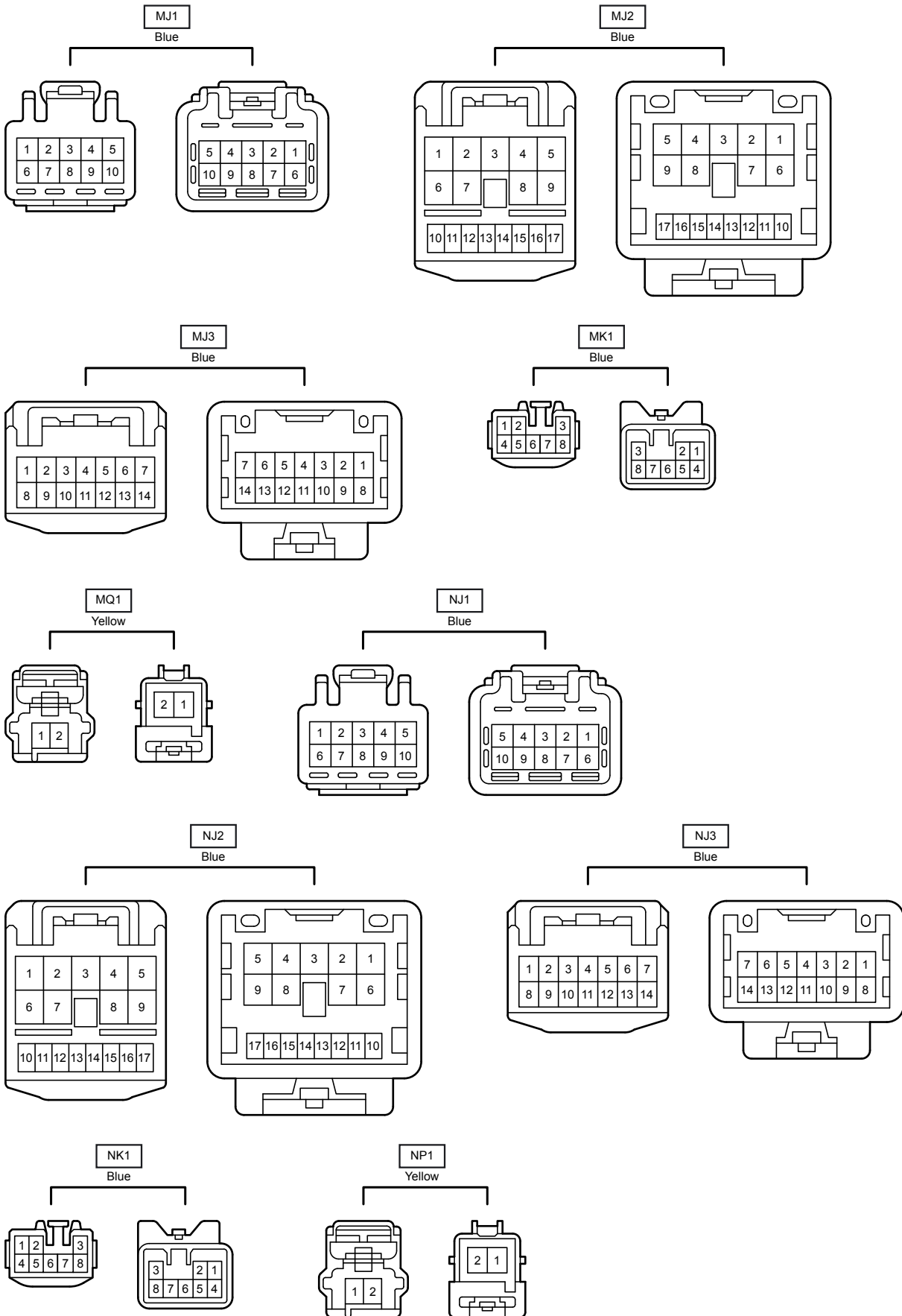

Wire and Wire in Instrument Panel <Column Shift>

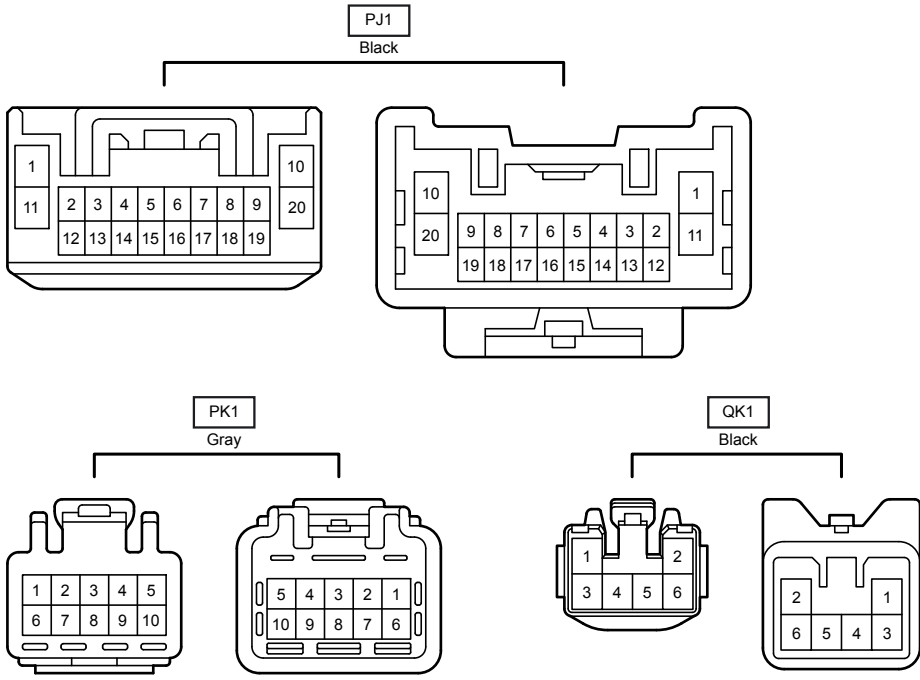

Ground Points in Instrument Panel <Floor Shift>

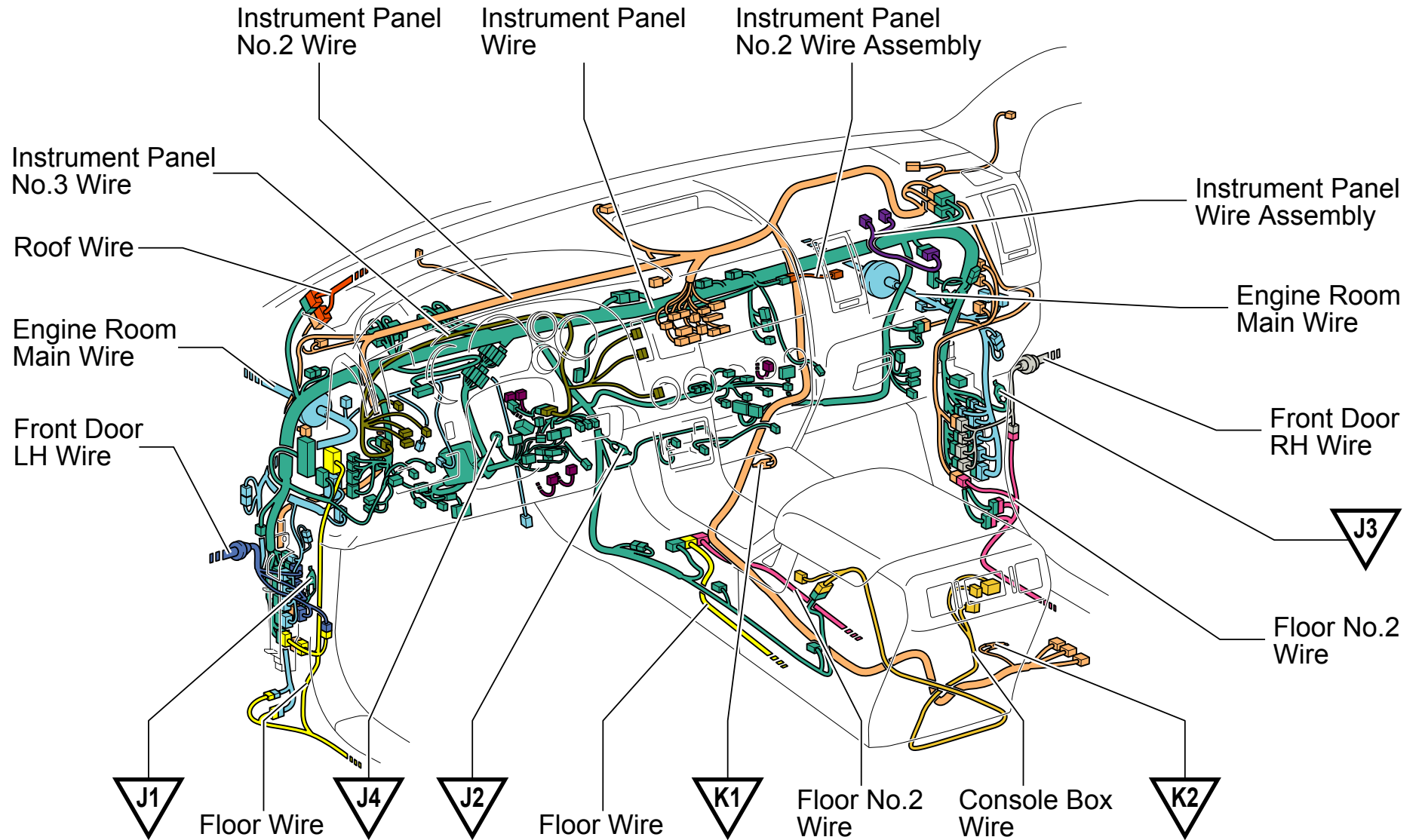

Position of Parts in Instrument Panel <Floor Shift>

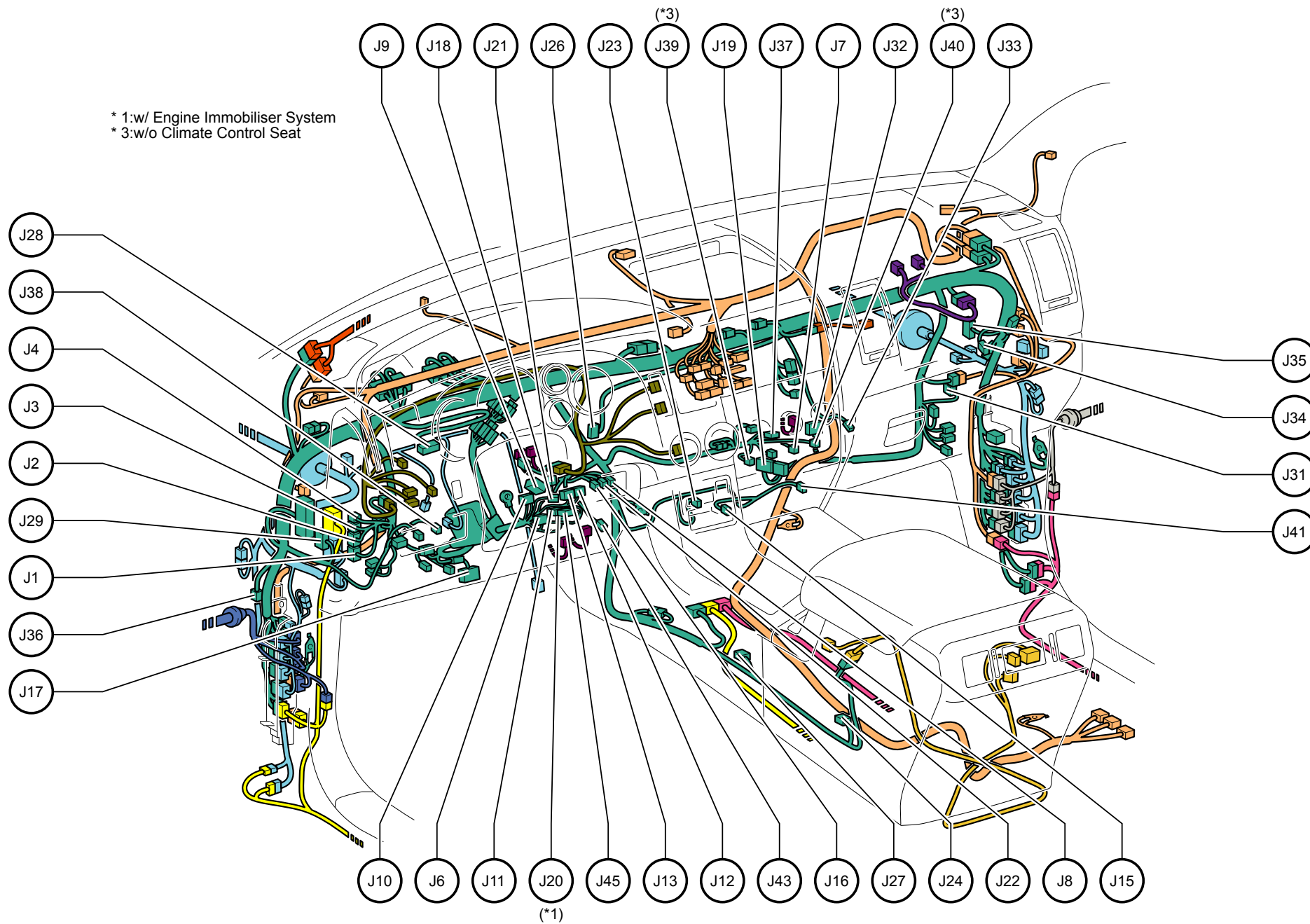

Position of Parts in Instrument Panel <Floor Shift>

---

- J 1 Main Body ECU
- J 2 Main Body ECU
- J 3 Main Body ECU
- J 4 Main Body ECU
- J 6 Steering Angle Sensor
- J 7 Stereo Jack Adapter
- J 8 Power Window Regulator Switch (for Back Window)
- J 9 Ignition Switch
- J 10 Headlight Dimmer Switch Assembly
- J 11 Spiral Cable
- J 12 Windshield Wiper Switch
- J 13 Windshield Wiper Switch
- J 15 Power Outlet Socket (No.4)
- J 16 Room Temperature Sensor
- J 17 DLC3
- J 18 Unlock Warning Switch
- J 19 A/C Amplifier
- J 20 Transponder Key Amplifier
- J 21 Key Interlock Solenoid
- J 22 VSC OFF Switch
- J 23 Tow/Haul Pattern Select Switch
- J 24 Transmission Control Switch
- J 26 Transponder Key ECU
- J 27 Shift Lock Control ECU
- J 28 Combination Meter
- J 29 Flasher Relay
- J 31 Tire Pressure Warning ECU
- J 32 Blower Motor
- J 33 Airbag Cutoff Switch
- J 34 Glove Box Illumination Light
- J 35 Clearance Sonar ECU
- J 36 Towing Brake Controller
- J 37 Integration Control and Panel Assembly
- J 38 Curtain Airbag Cutoff Switch
- J 39 Seat Heater Switch LH
- J 40 Seat Heater Switch RH
- J 41 Power Outlet Socket (No.1)
- J 43 Tire Pressure Warning Reset Switch
- J 45 Spiral Cable

Position of Parts in Instrument Panel <Floor Shift>

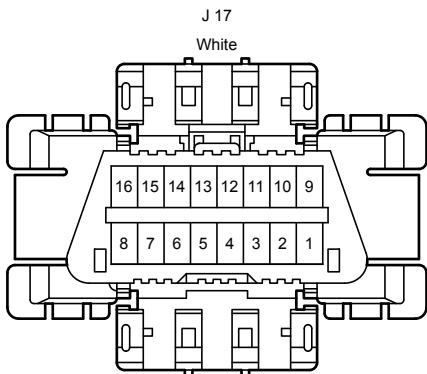
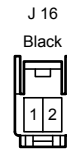
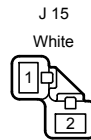
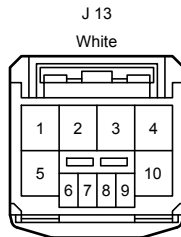
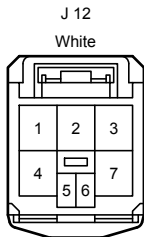
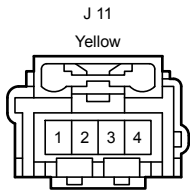
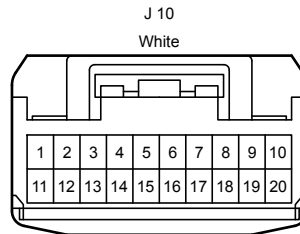
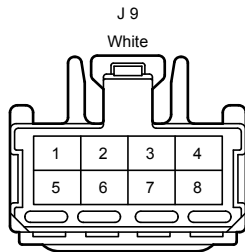
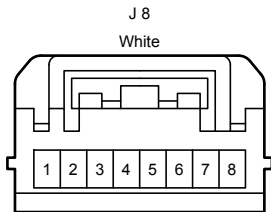
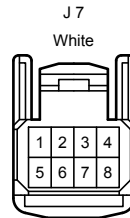
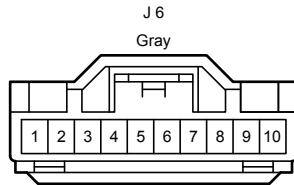
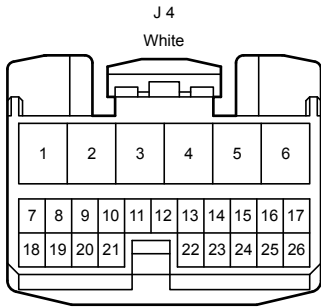
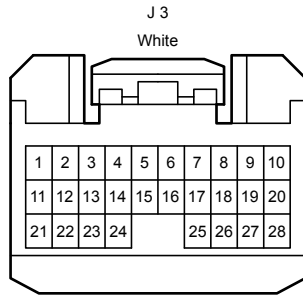
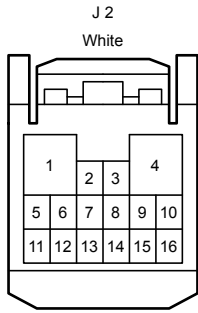
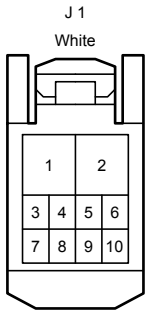





J 45  
Black

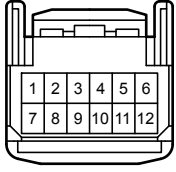

Position of Parts in Instrument Panel <Floor Shift>

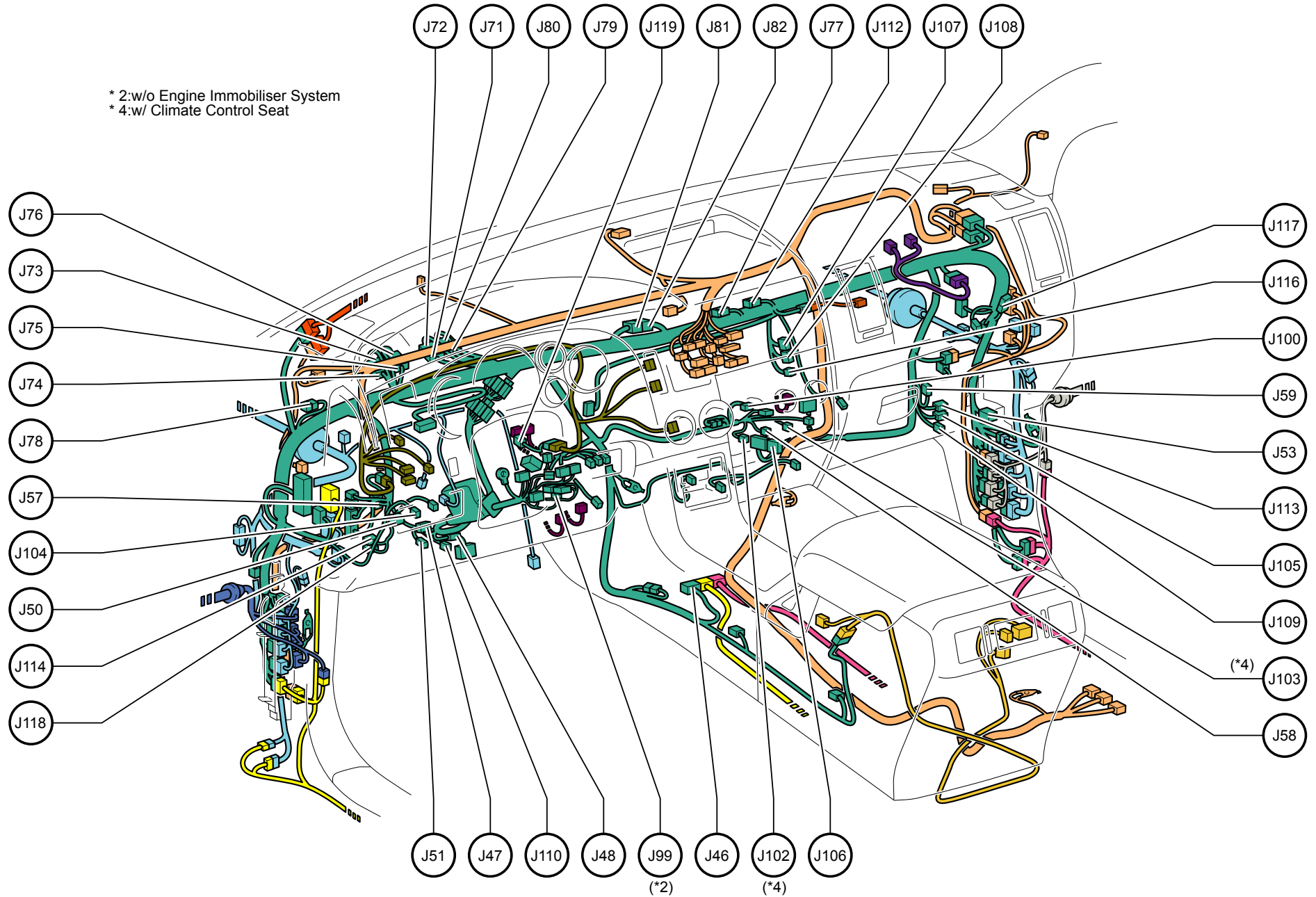

Position of Parts in Instrument Panel <Floor Shift>

---

- J 46 Center Airbag ECU
- J 47 Multiplex Tilt and Telescopic ECU
- J 48 Power Tilt Motor
- J 50 Cargo Light Switch
- J 51 Foot Light
- J 53 ACC Cut Relay
- J 57 Glass Breakage Sensor ECU
- J 58 Glass Breakage Sensor Microphone
- J 59 Bus Buffer
- J 71 Junction Connector
- J 72 Junction Connector
- J 73 Junction Connector
- J 74 Junction Connector
- J 75 Junction Connector
- J 76 Junction Connector
- J 77 Junction Connector
- J 78 Junction Connector
- J 79 Junction Connector
- J 80 Junction Connector
- J 81 Junction Connector
- J 82 Junction Connector
- J 99 Ignition Key Cylinder Light
- J 100 Stereo Jack Adapter Assembly
- J 102 Front Seat Heater Switch LH
- J 103 Front Seat Heater Switch RH
- J 104 Headlight Levering Switch
- J 105 Back Up Light Relay
- J 106 A/C Amplifier
- J 107 Multi-Media Interface ECU
- J 108 Multi-Media Interface ECU
- J 109 No.1 Instrument Panel Airbag Assembly Lower RH
- J 110 No.1 Instrument Panel Airbag Assembly Lower LH
- J 112 Junction Connector
- J 113 Junction Connector
- J 114 Junction Connector
- J 116 Multi-Media Interface ECU
- J 117 Junction Connector
- J 118 Junction Connector
- J 119 Power Steering ECU Assembly

Position of Parts in Instrument Panel <Floor Shift>

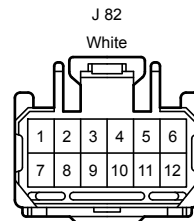
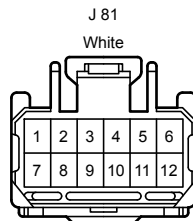
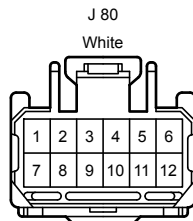
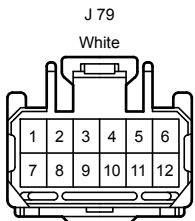
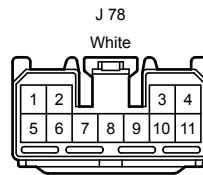
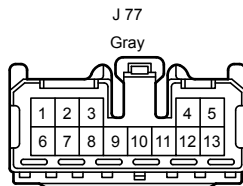
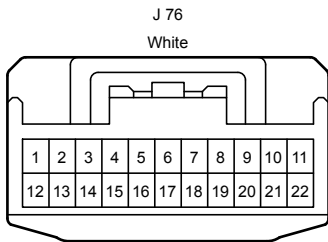
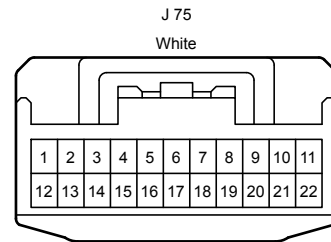
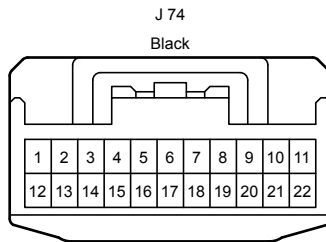
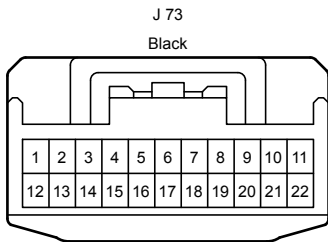
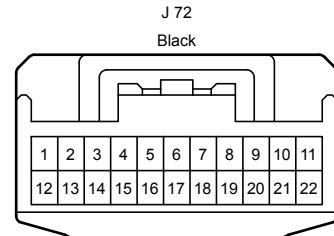
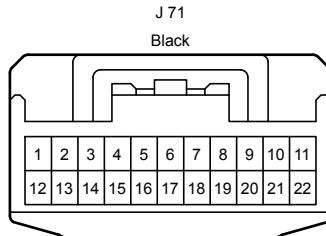
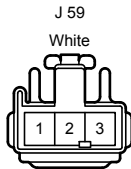
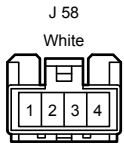
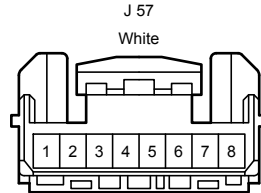
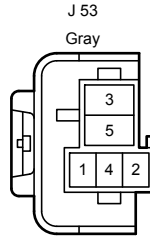
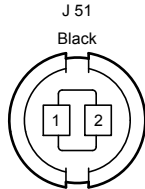
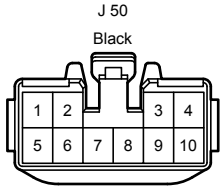
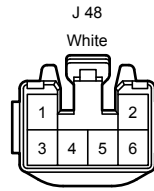
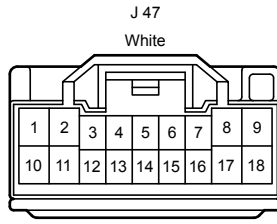
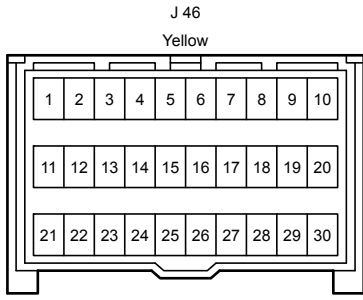

Position of Parts in Instrument Panel <Floor Shift>

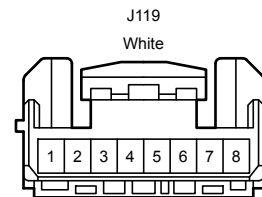
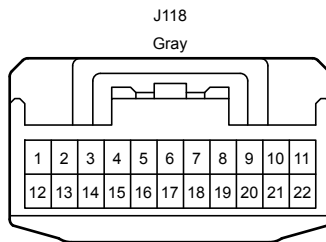
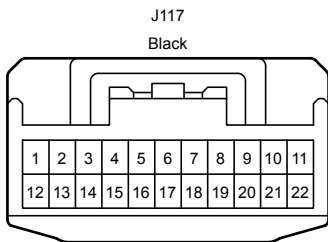
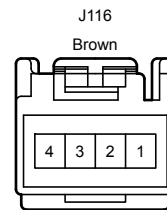
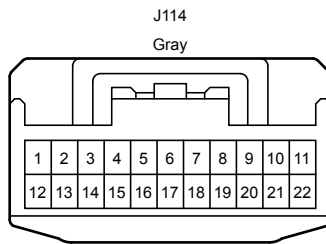
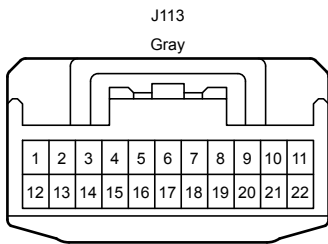
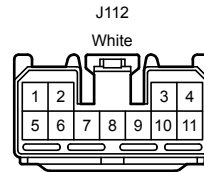
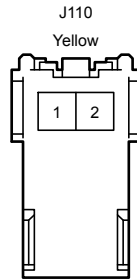
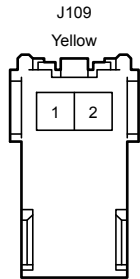
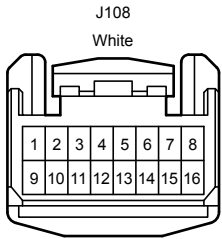
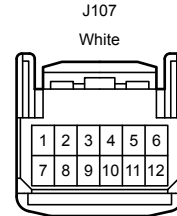
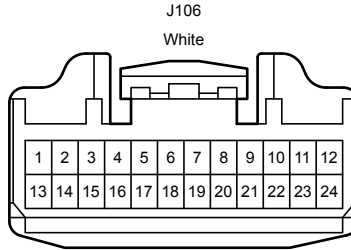
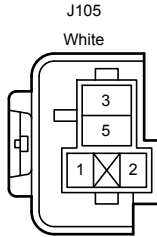
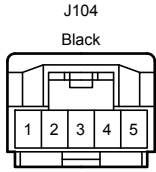
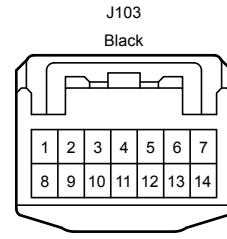
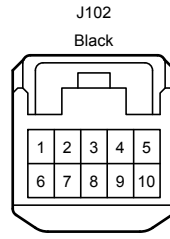
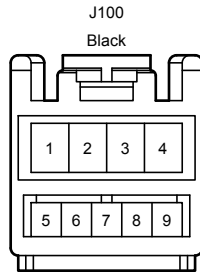
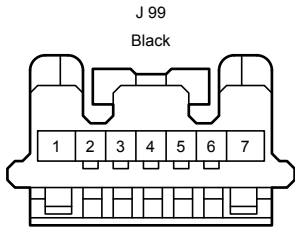

Position of Parts in Instrument Panel <Floor Shift>

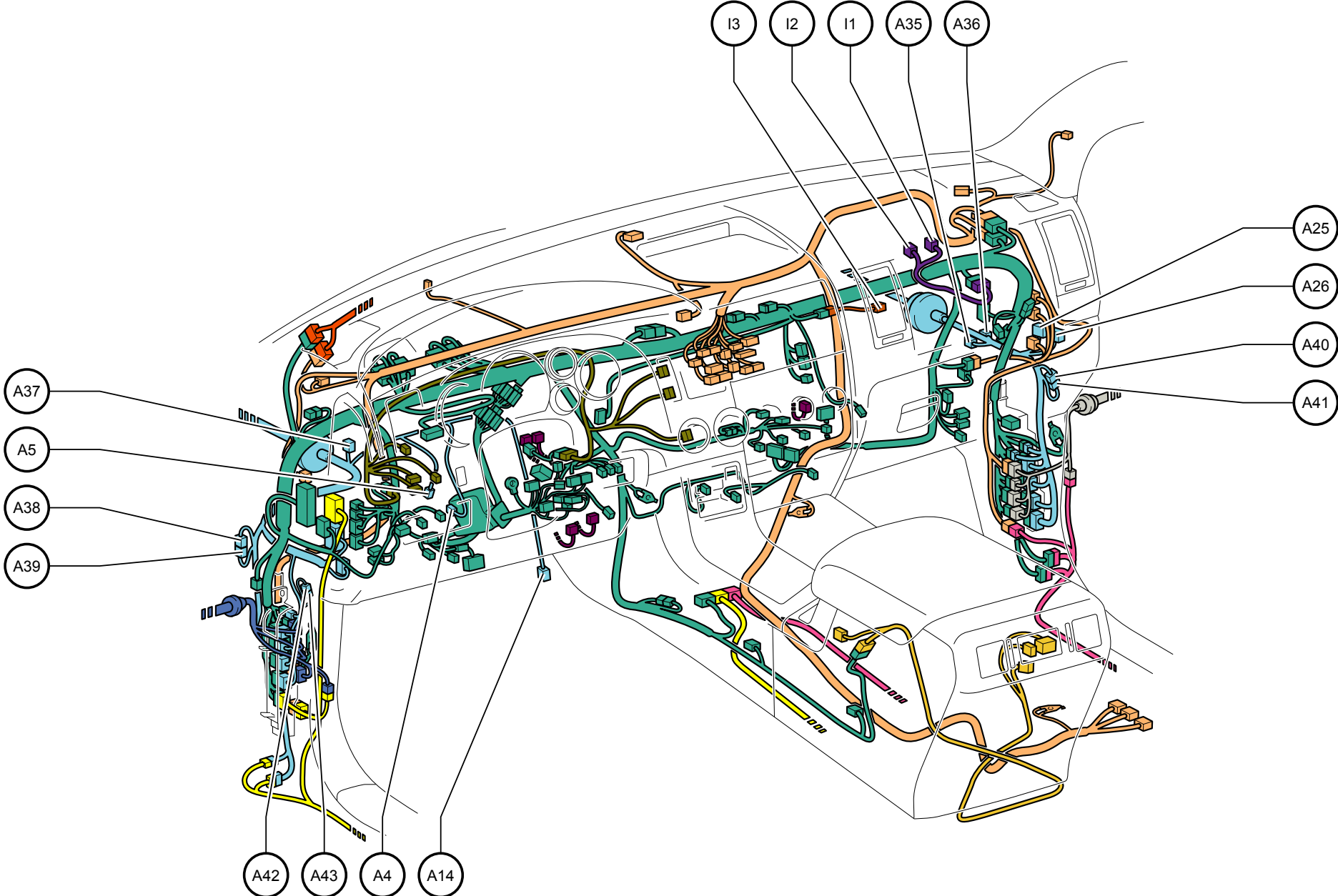

**Position of Parts in Instrument Panel <Floor Shift>**

---

- A 4 Stop Light Switch
- A 5 Parking Brake Switch
- A 14 Accelerator Position Sensor
- A 25 4WD Control ECU
- A 26 4WD Control ECU
- A 35 Diode (Starting)
- A 36 Junction Connector
- A 37 Junction Connector
- A 38 Junction Connector
- A 39 Junction Connector
- A 40 Junction Connector
- A 41 Junction Connector
- A 42 Junction Connector
- A 43 Junction Connector

- I 1 Front Passenger Side Squib Circuit
- I 2 Front Passenger Side Squib Circuit
- I 3 Front Passenger Side Squib Circuit



Position of Parts in Instrument Panel <Floor Shift>

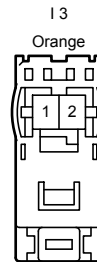
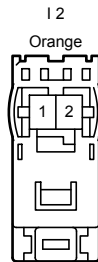
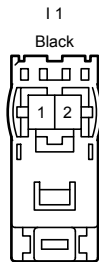
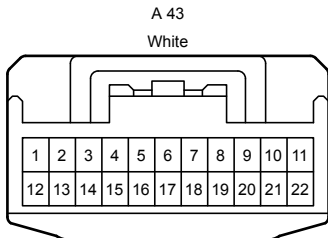
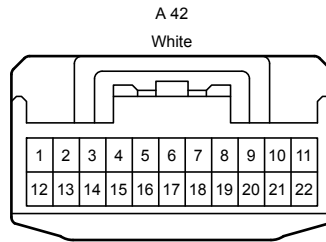
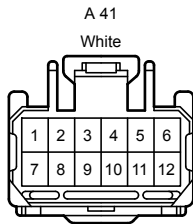
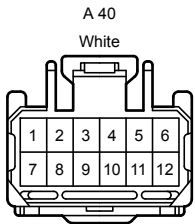
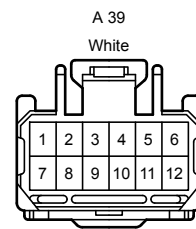
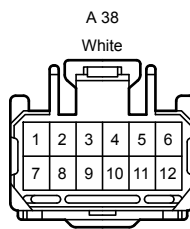
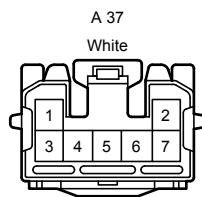
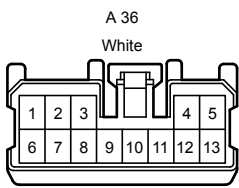
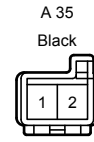
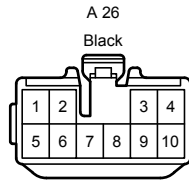
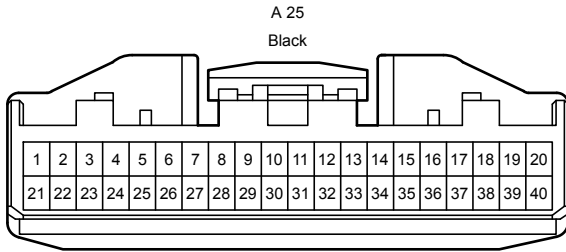
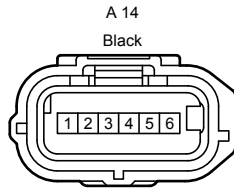
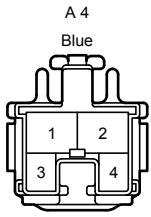

Position of Parts in Instrument Panel <Floor Shift>

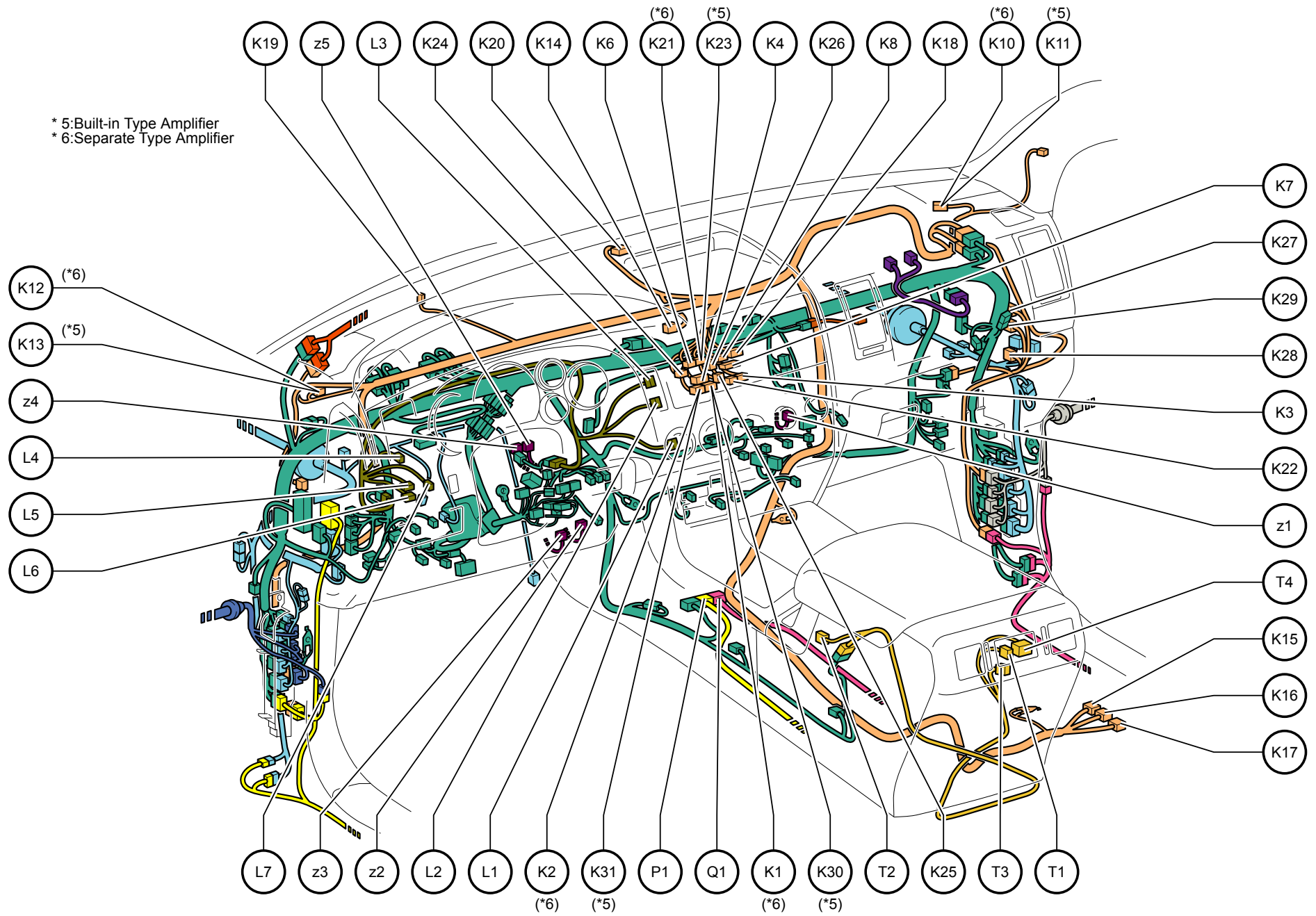

Position of Parts in Instrument Panel <Floor Shift>

---

- K 1 Radio Receiver Assembly
- K 2 Radio Receiver Assembly
- K 3 Radio Receiver Assembly
- K 4 Radio Receiver Assembly
- K 6 Navigation Receiver Assembly
- K 7 Navigation Receiver Assembly
- K 8 Navigation Receiver Assembly
- K 10 Front Side Speaker RH
- K 11 Front Side Speaker RH
- K 12 Front Side Speaker LH
- K 13 Front Side Speaker LH
- K 14 Center Speaker
- K 15 Stereo Component Amplifier
- K 16 Stereo Component Amplifier
- K 17 Stereo Component Amplifier
- K 18 Navigation Receiver Assembly
- K 19 Light Control Sensor
- K 20 Accessory Meter Assembly
- K 21 Navigation Receiver Assembly
- K 22 Radio Receiver Assembly
- K 23 Navigation Receiver Assembly
- K 24 Navigation Receiver Assembly
- K 25 Radio Receiver Assembly
- K 26 Navigation Receiver Assembly
- K 27 Stereo Component Tuner Assembly
- K 28 Stereo Component Tuner Assembly
- K 29 Stereo Component Tuner Assembly
- K 30 Navigation Receiver Assembly
- K 31 Navigation Receiver Assembly
  
- L 1 4WD Control Switch
- L 2 Drive Monitor Switch
- L 3 Hazard Warning Signal Switch
- L 4 Light Control Rheostat
- L 5 Outer Mirror Switch
- L 6 Outer Mirror Switch
- L 7 Room Lamp Switch
  
- P 1 Center Airbag ECU
  
- Q 1 Center Airbag ECU
  
- T 1 Power Outlet Socket (115V)
- T 2 Power Outlet Socket (No.2)
- T 3 Power Outlet Socket (No.3)
- T 4 Video Terminal
  
- z 1 A/C Amplifier , A/C Blower Assembly
- z 2 Spiral Cable , Cruise Control Main Switch
- z 3 Spiral Cable , Steering Pad Switch
- z 4 Spiral Cable , Driver Side Squib Circuit
- z 5 Spiral Cable , Driver Side Squib 2nd Step Circuit

Position of Parts in Instrument Panel <Floor Shift>

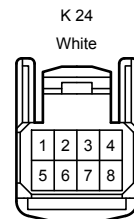
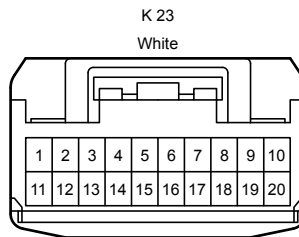
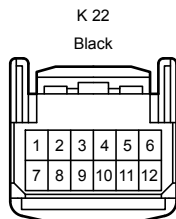
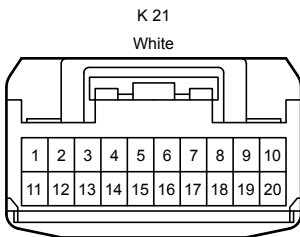
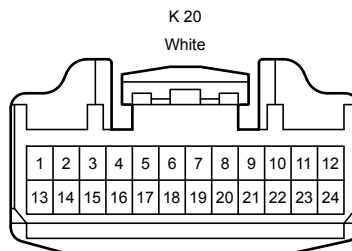
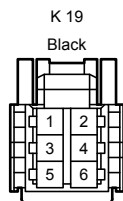
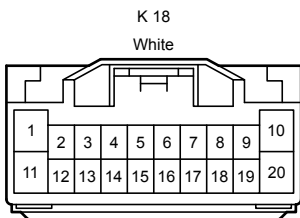
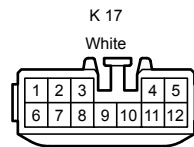
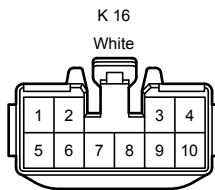
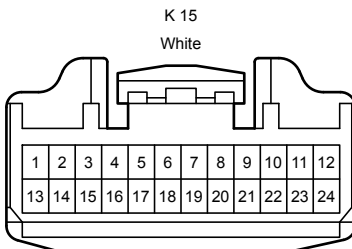
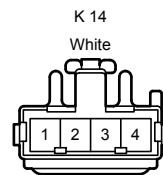
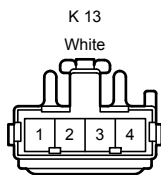
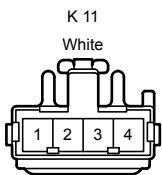
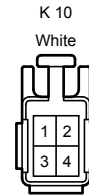
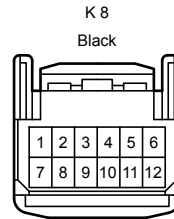
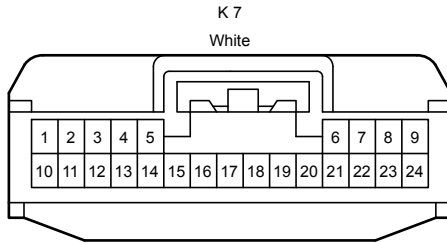
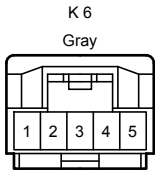
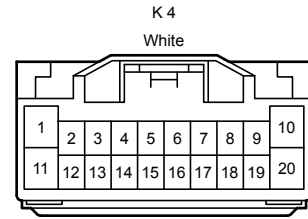
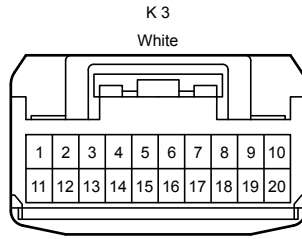
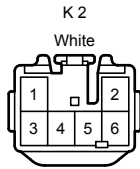
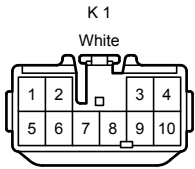

Position of Parts in Instrument Panel <Floor Shift>

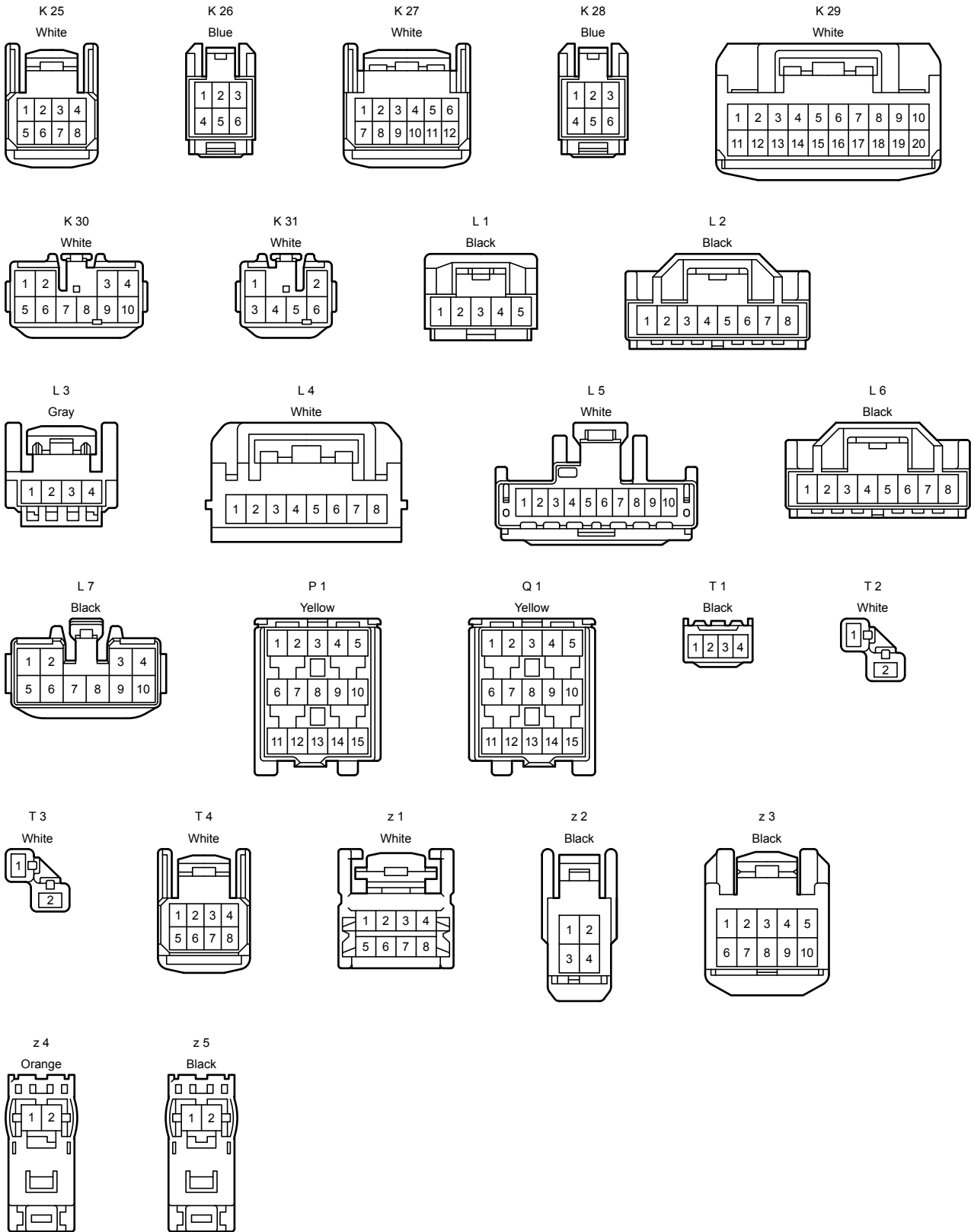

**[Instrument Panel]  
(Floor Shift)**

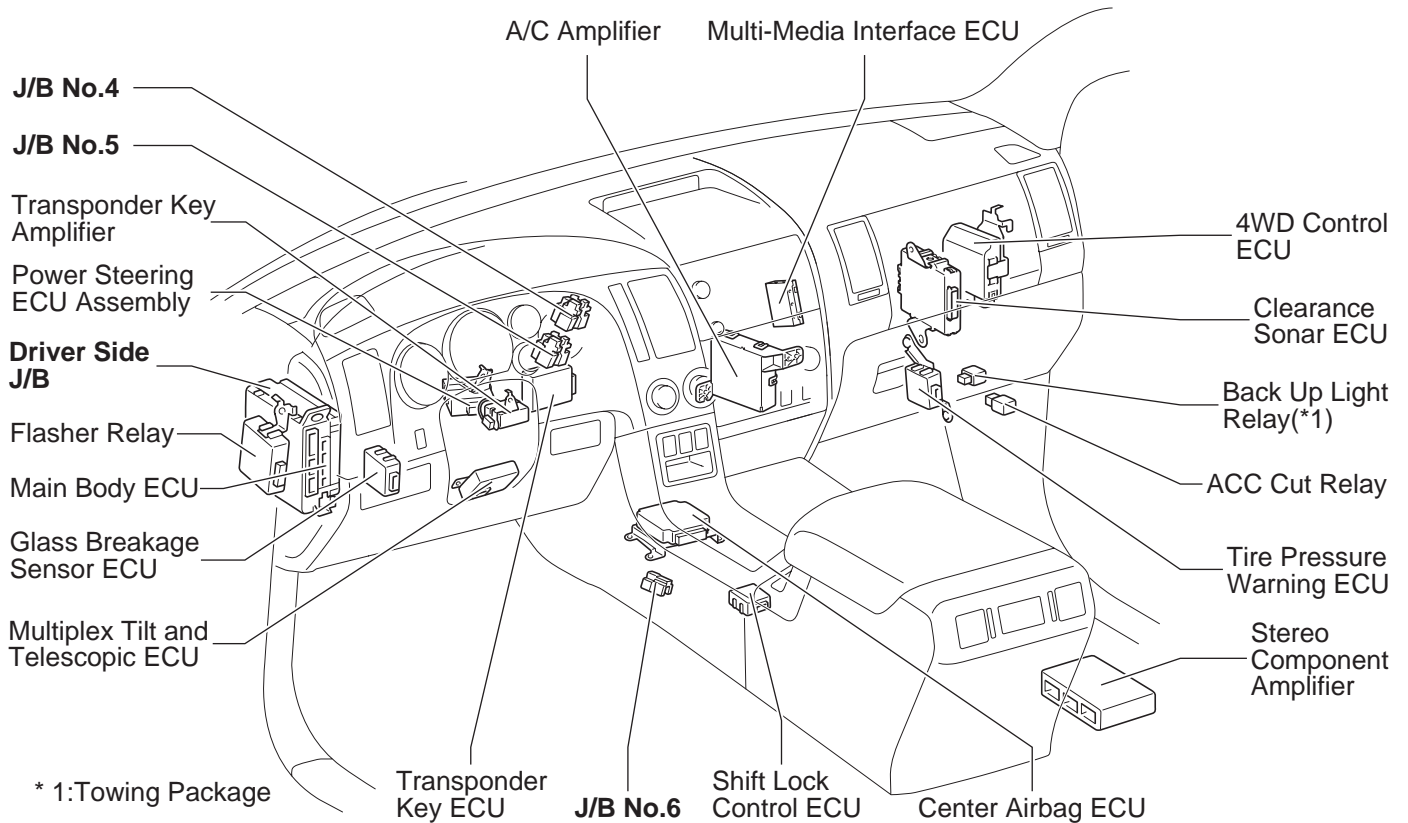

**(Column Shift)**

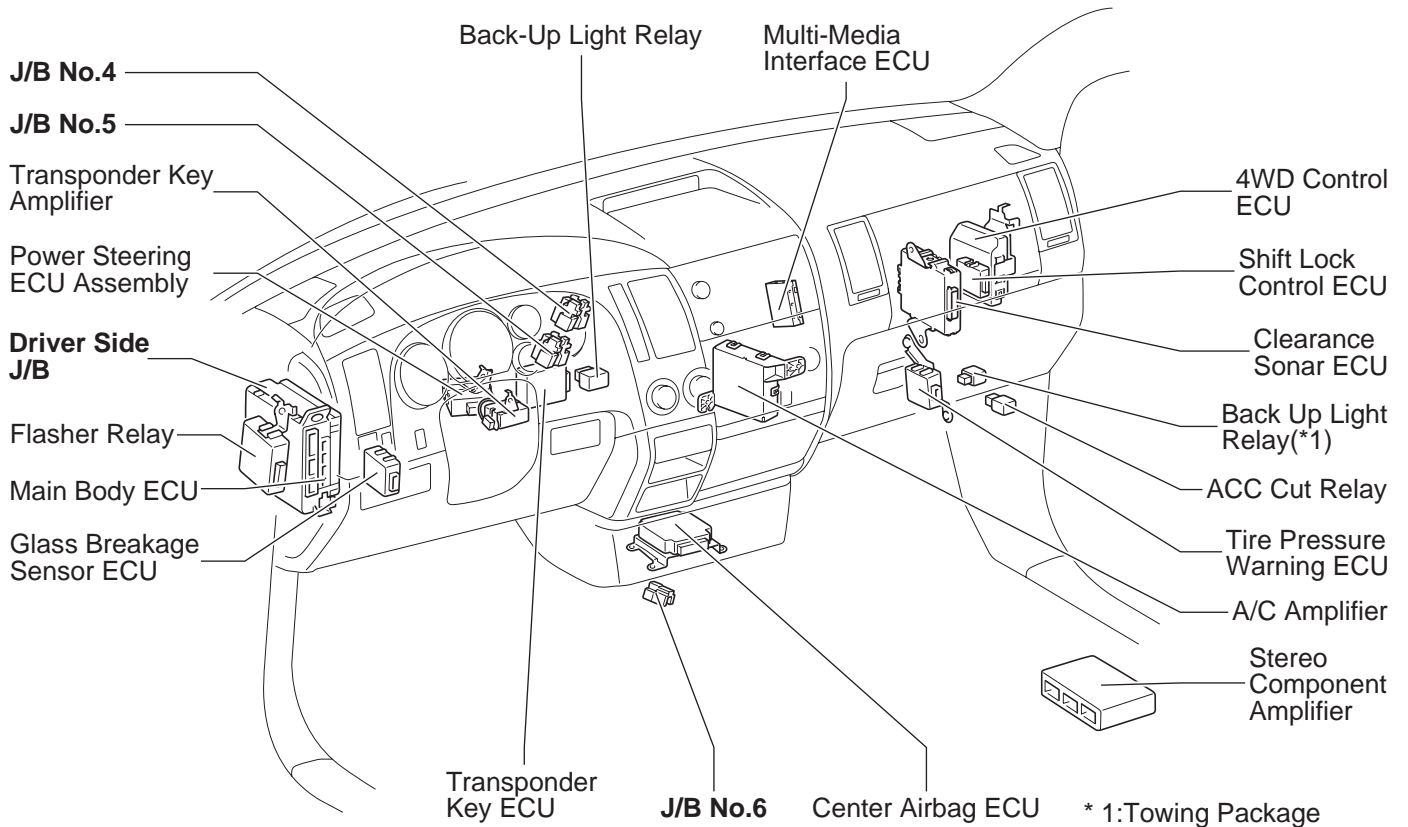

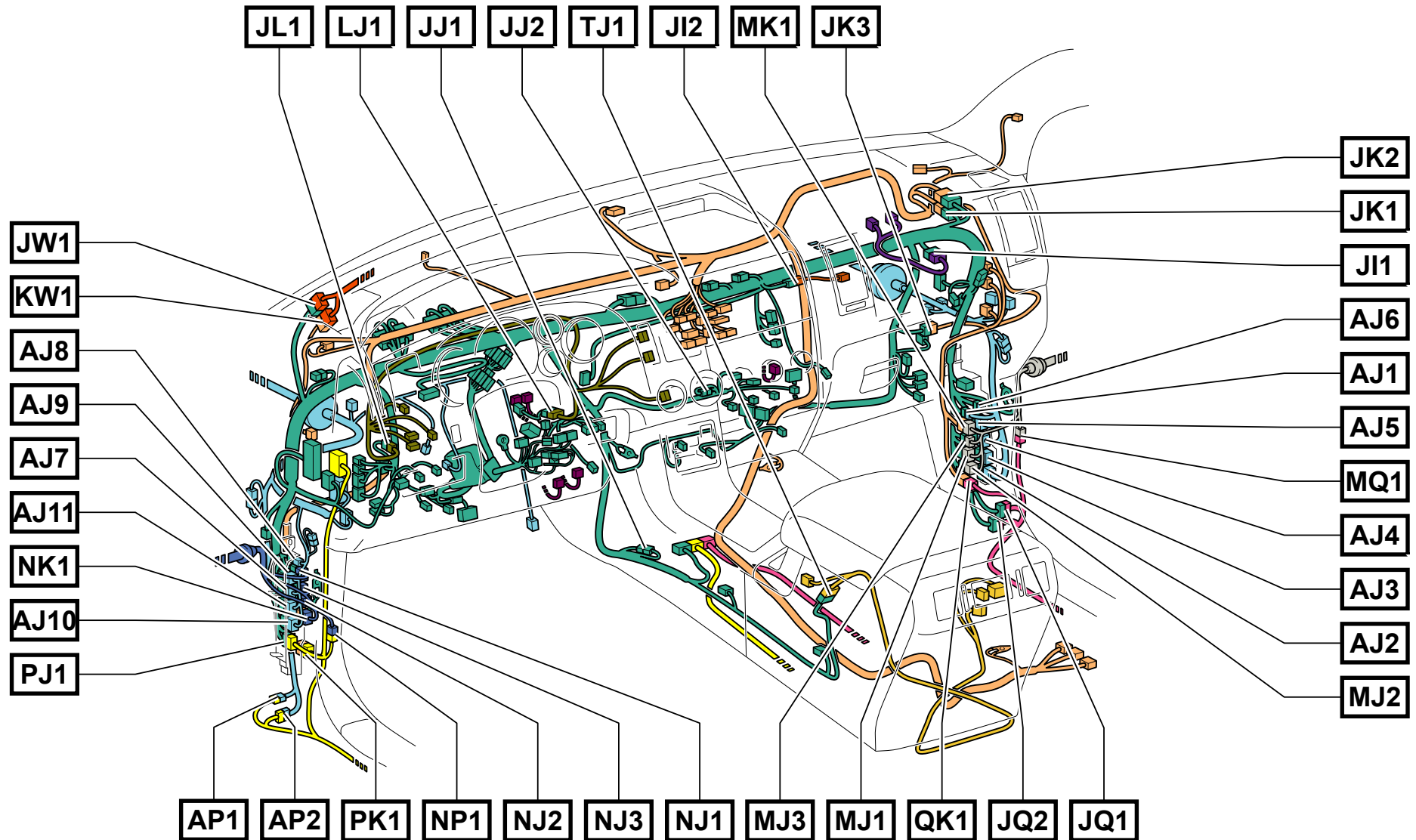

Wire and Wire in Instrument Panel <Floor Shift>

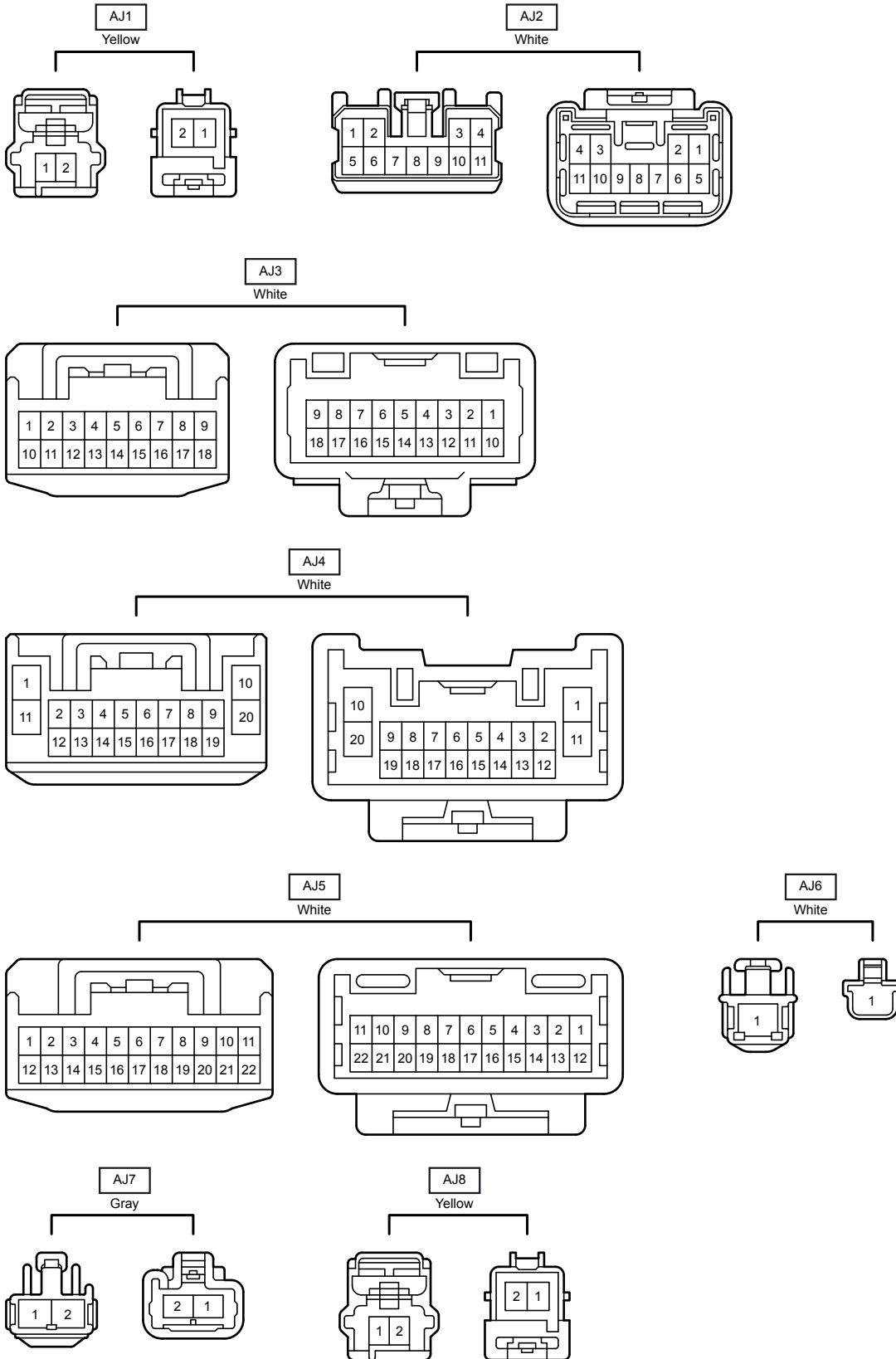



Wire and Wire in Instrument Panel <Floor Shift>

AJ9  
Gray

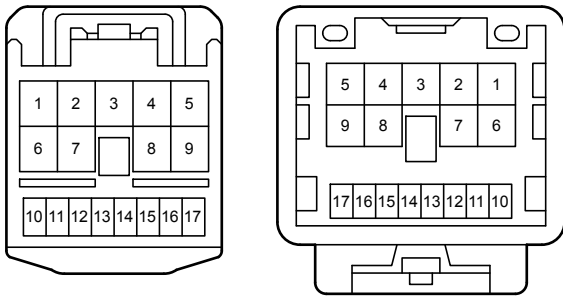

AJ10  
Gray

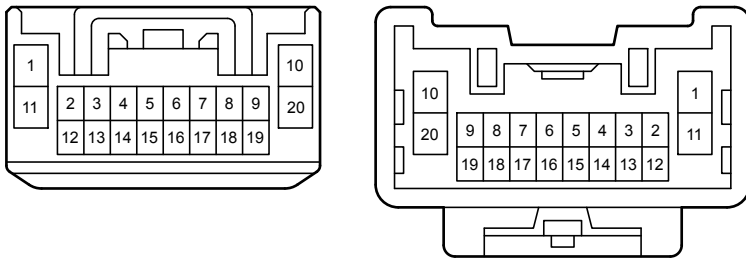

AJ11  
Gray

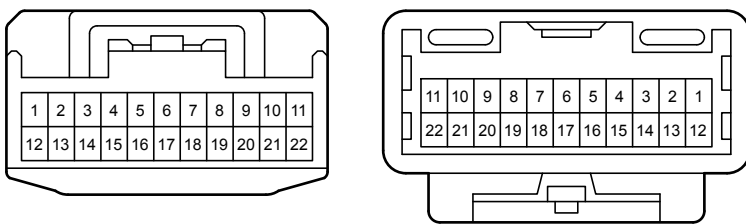

AP1  
White

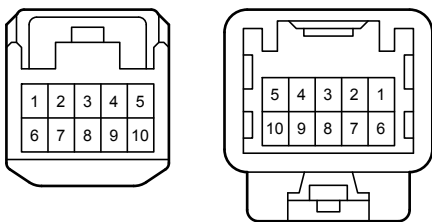

AP2  
White

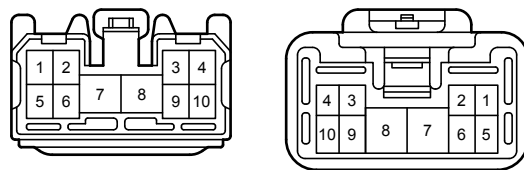

J11  
Yellow

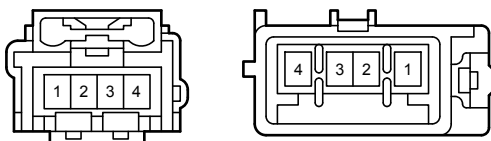

J12  
Yellow Orange

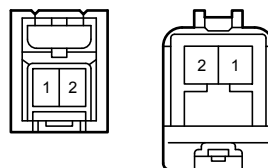

Wire and Wire in Instrument Panel <Floor Shift>

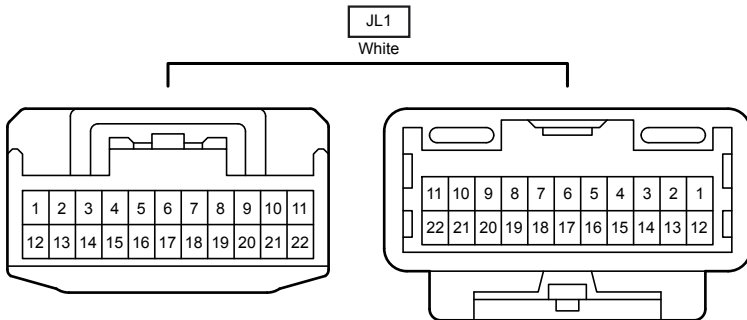
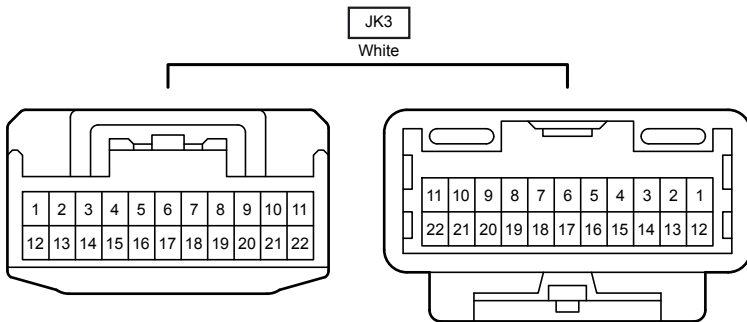
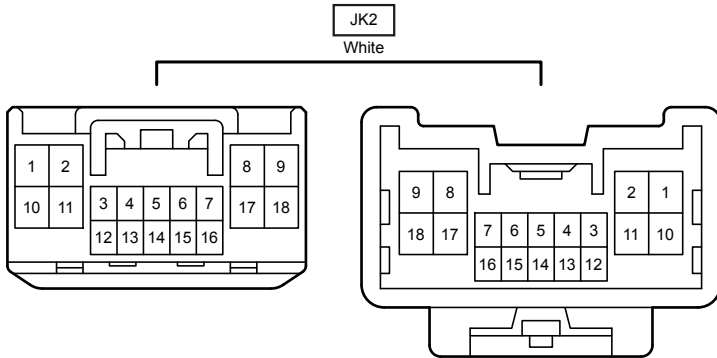
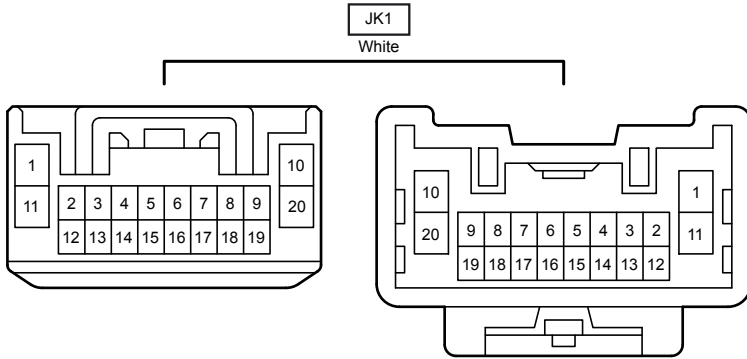
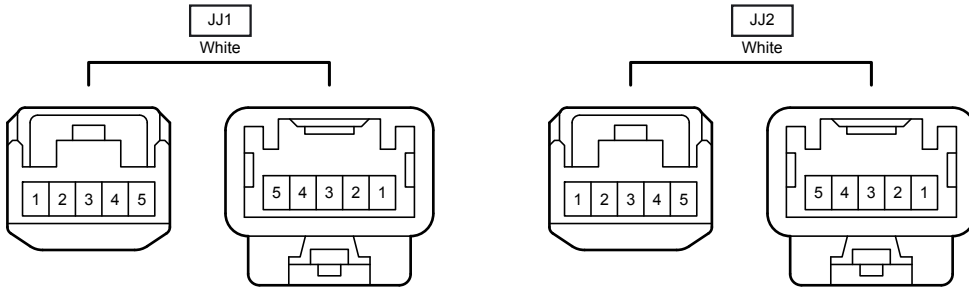

Wire and Wire in Instrument Panel <Floor Shift>

JQ1  
Gray

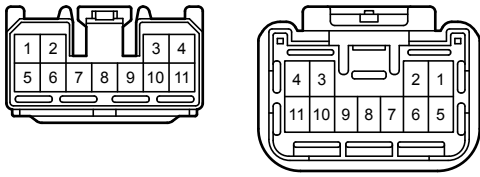

JQ2  
Gray

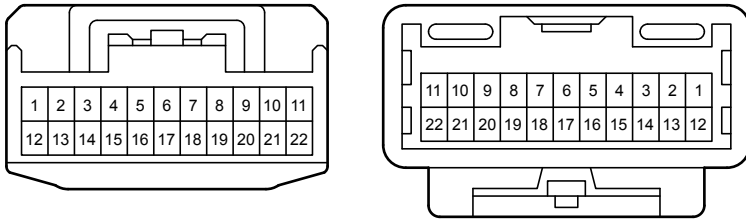

JW1  
White

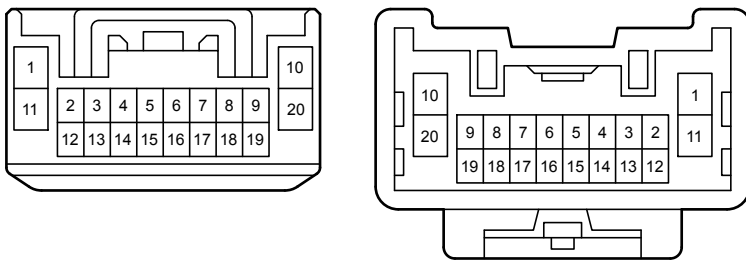

KW1  
White

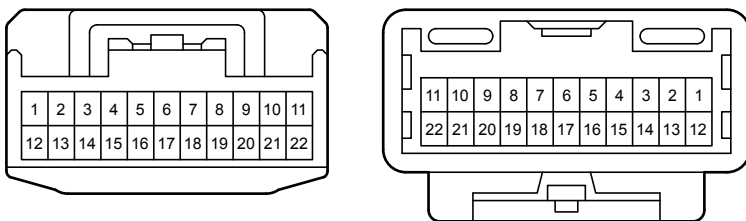

LJ1  
White

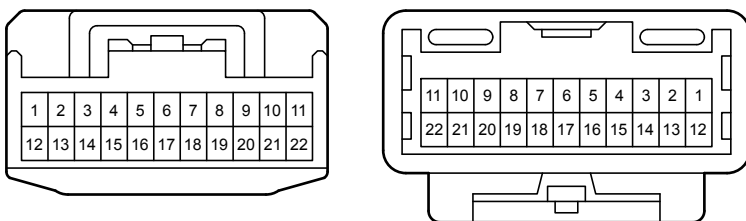

Wire and Wire in Instrument Panel <Floor Shift>

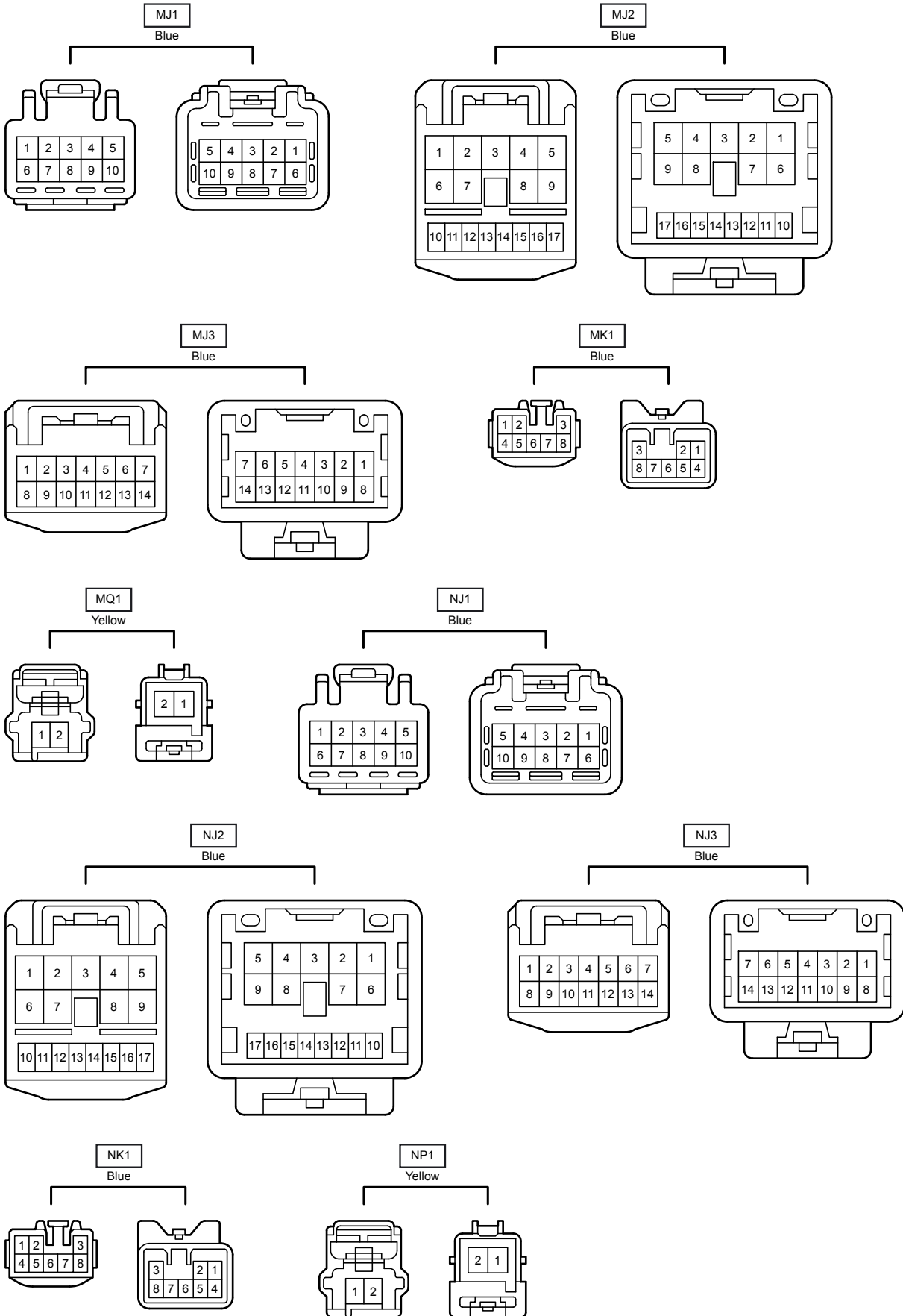

Wire and Wire in Instrument Panel <Floor Shift>

PJ1  
Black

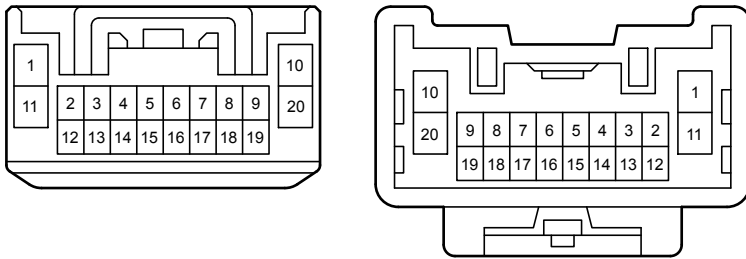

PK1  
Gray

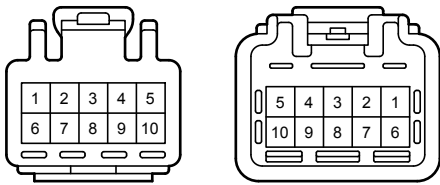

QK1  
Black

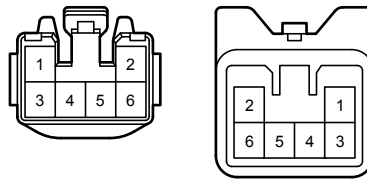

TJ1  
White

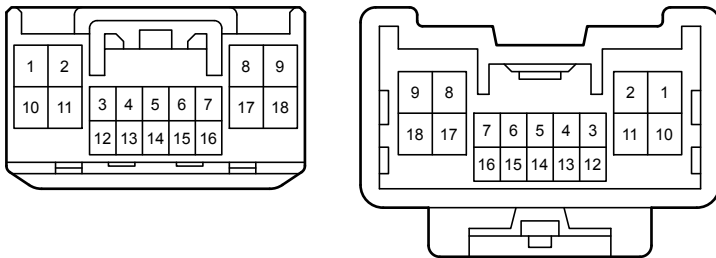

# F RELAY LOCATIONS

○ : J/B No.4	Instrument Panel Center (See Page 21)
--------------	---------------------------------------

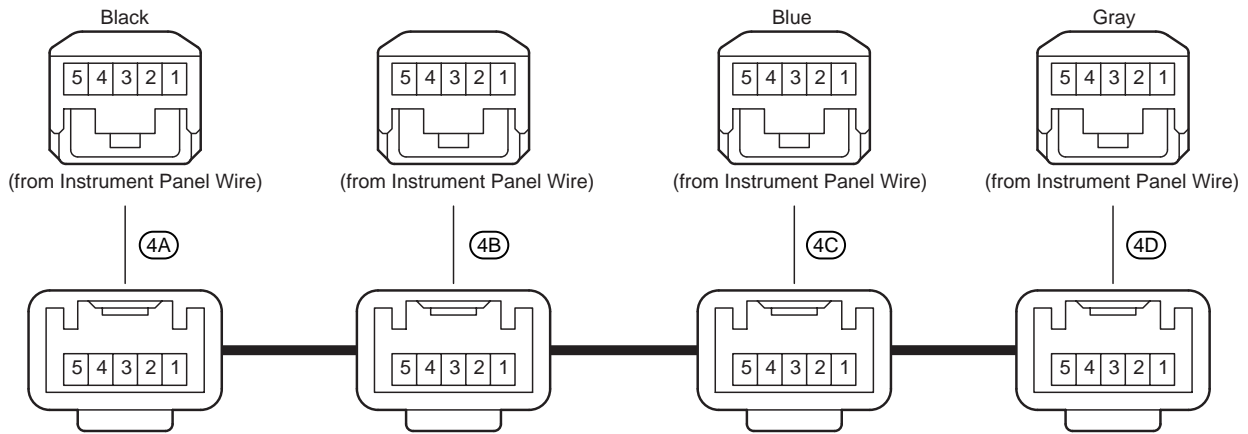

[J/B No.4 Inner Circuit]

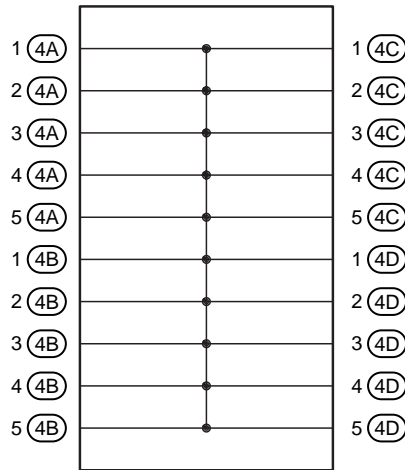

# F RELAY LOCATIONS

○ : J/B No.5	Instrument Panel Center (See Page 21)
--------------	---------------------------------------

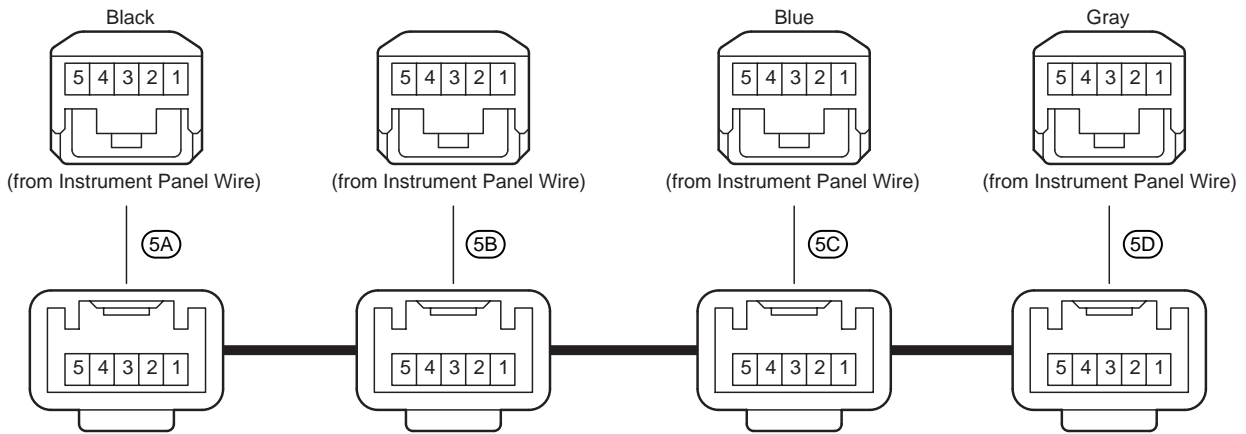



[J/B No.5 Inner Circuit]

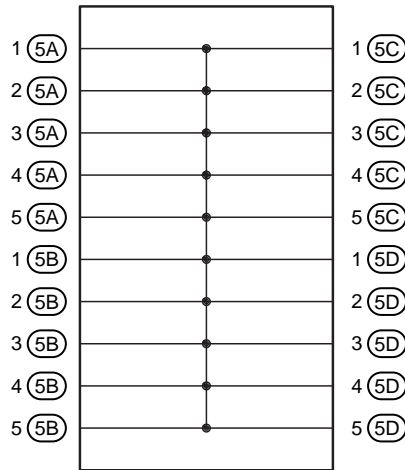

# F RELAY LOCATIONS

○ : J/B No.6	Instrument Panel Center (See Page 21)
--------------	---------------------------------------

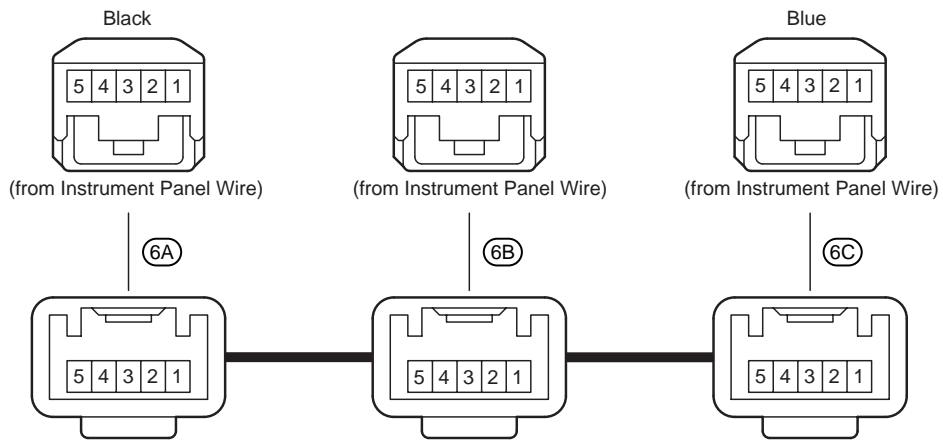

[J/B No.6 Inner Circuit]

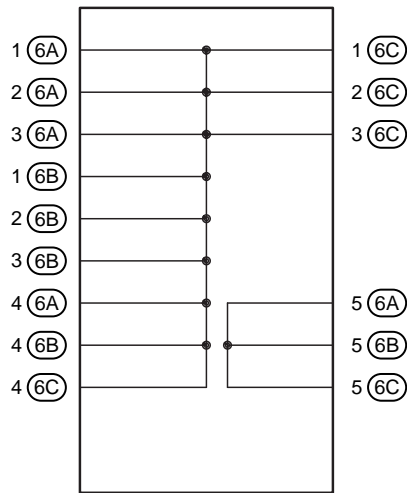

# F RELAY LOCATIONS

---

[Seat]  
(Separate Seat)

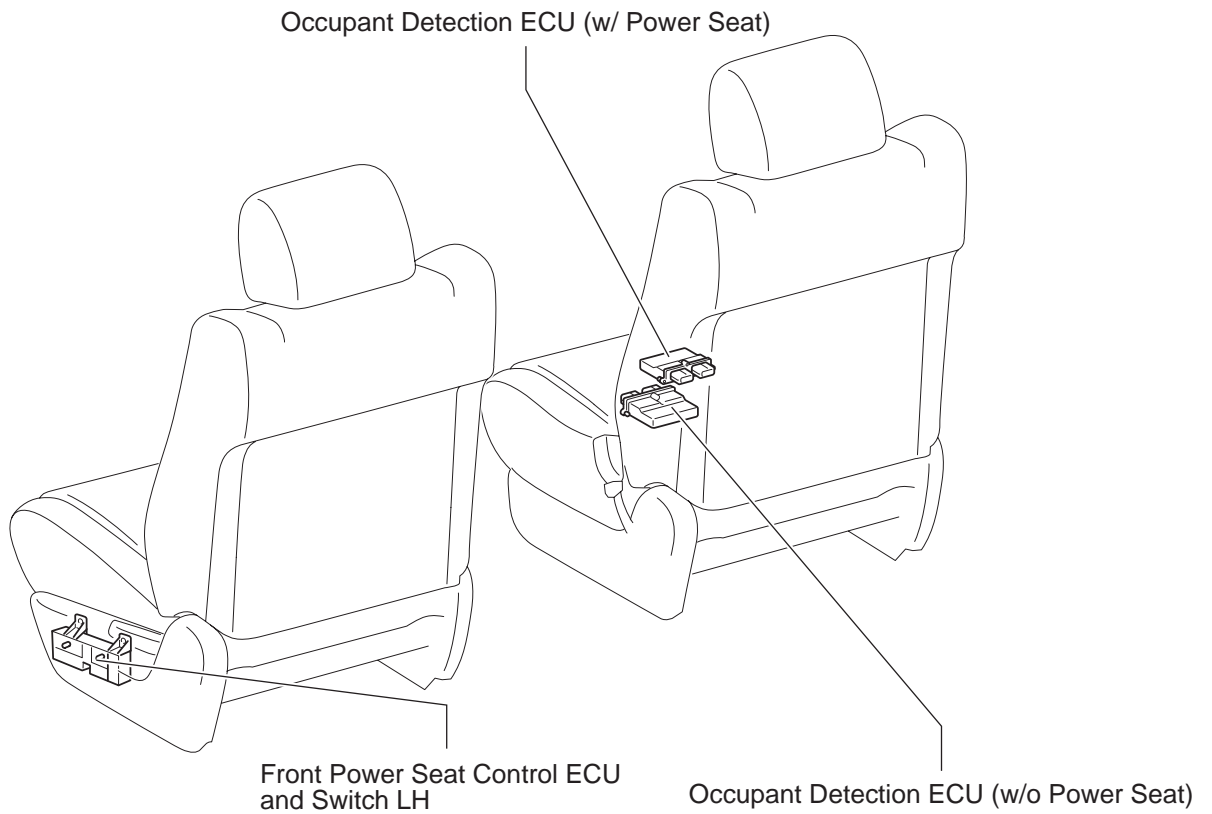

(Bench Seat)

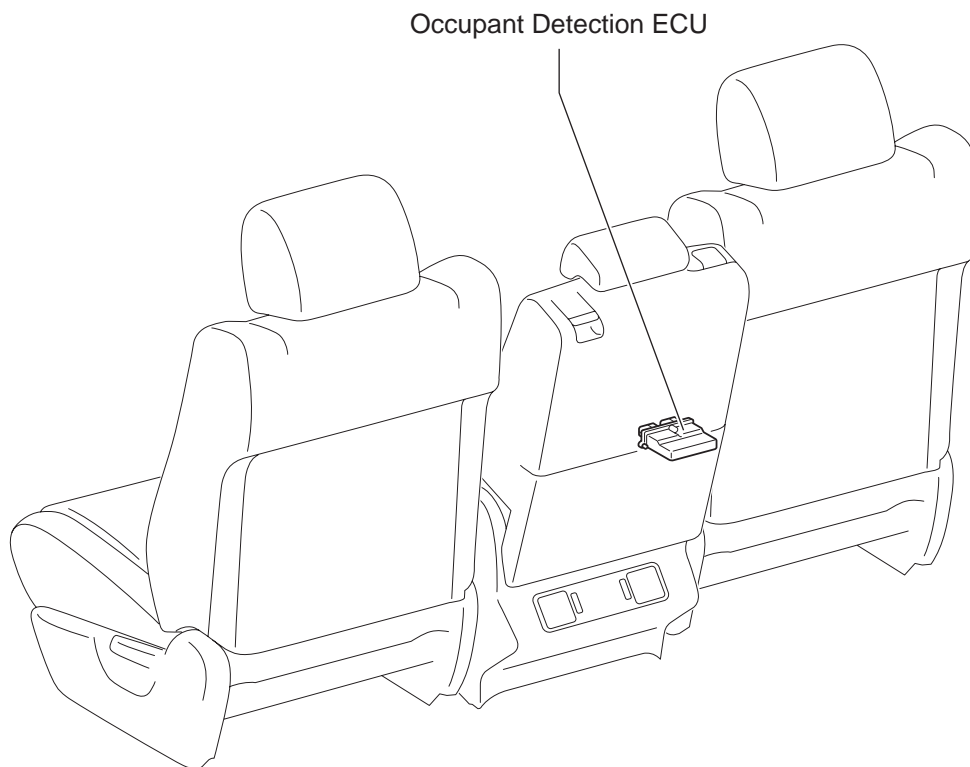

# F RELAY LOCATIONS

---

**[Seat]**  
**(Separate Seat)**

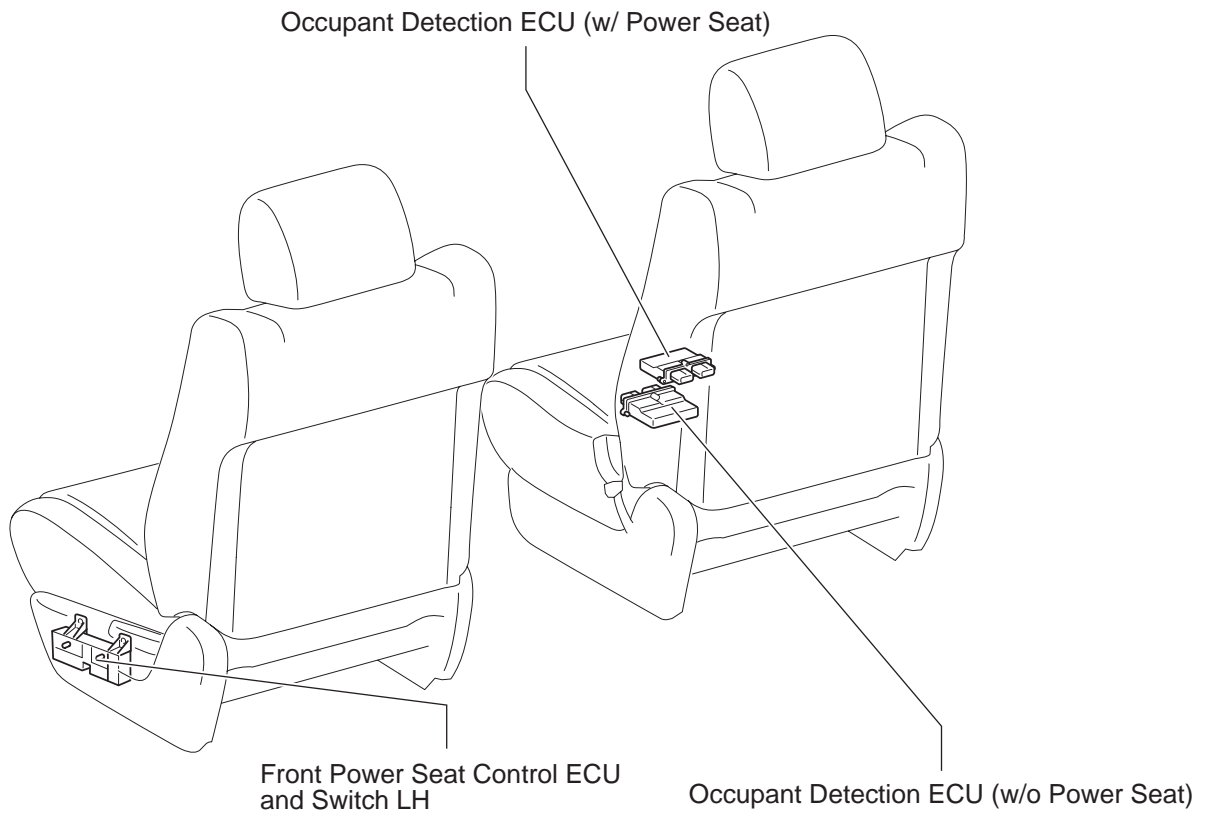

**(Bench Seat)**

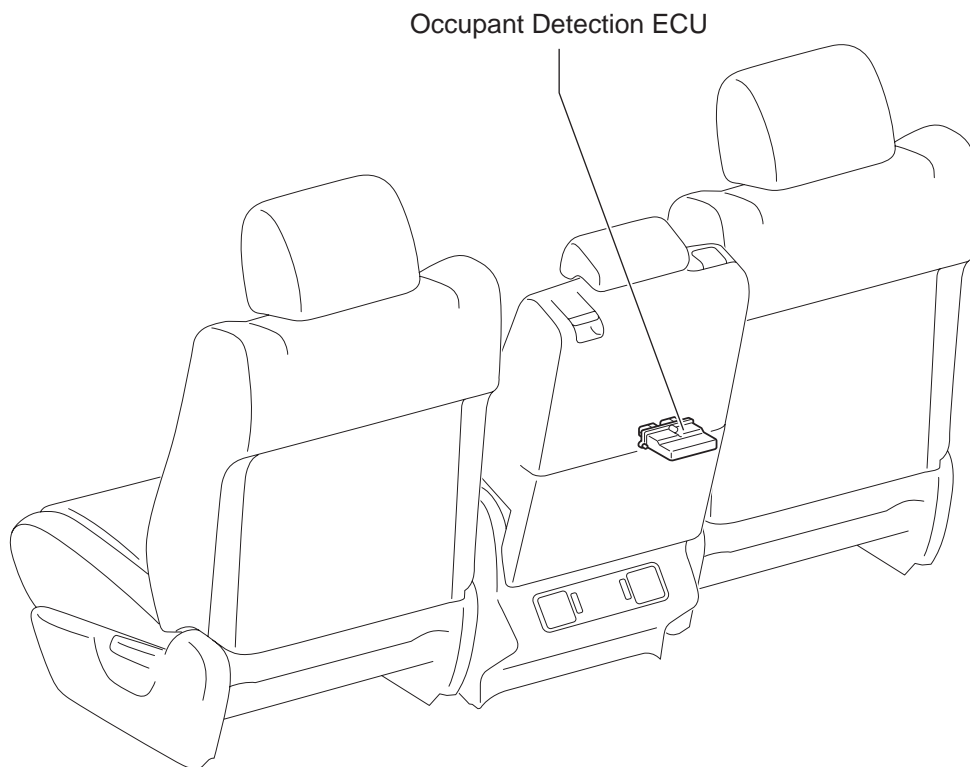

Position of Parts in Seat <Separate Seat>

\* 1:w/o Power Seat  
 \* 2:w/ Power Seat

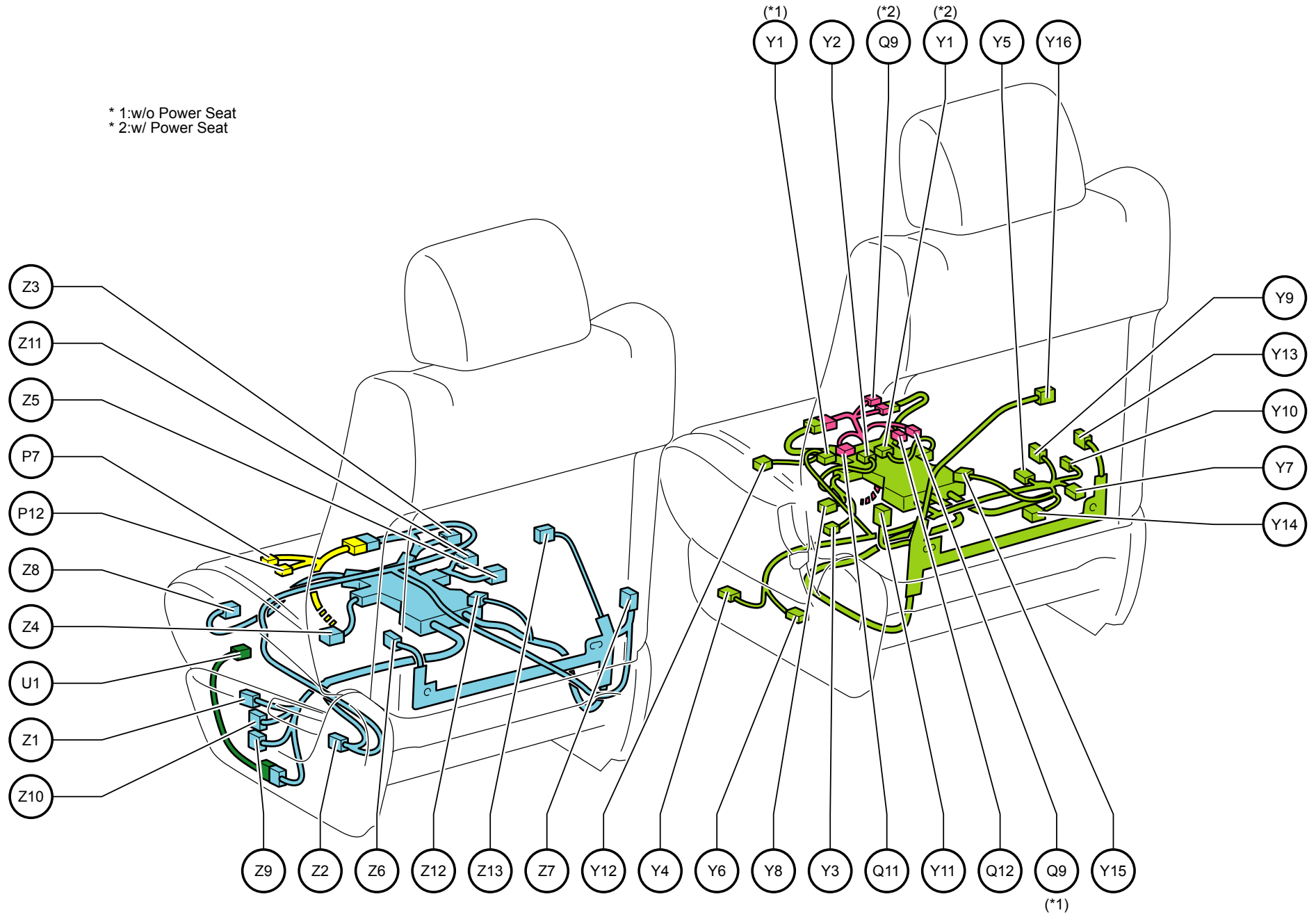

Position of Parts in Seat <Separate Seat>

---

- P 7 Front Seat Inner Belt Switch LH
- P 12 Front Side Airbag Squib Circuit LH
  
- Q 9 Front Side Airbag Squib Circuit RH
- Q 11 Occupant Detection ECU
- Q 12 Front Seat Inner Belt Switch RH
  
- U 1 Front Power Seat Switch LH (Seat Cushion Control)
  
- Y 1 Occupant Detection ECU
- Y 2 Occupant Detection ECU
- Y 3 Front Seat Inner Belt Switch LH
- Y 4 Front Occupant Classification Sensor LH
- Y 5 Front Occupant Classification Sensor RH
- Y 6 Rear Occupant Classification Sensor LH
- Y 7 Rear Occupant Classification Sensor RH
- Y 8 Front Seat Heater RH
- Y 9 Front Power Seat Switch RH
- Y 10 Front Power Seat Switch RH (Lumbar Support Control)
- Y 11 Front Lumbar Support Motor RH
- Y 12 Front Power Seat Position Motor RH (Slide Position)
- Y 13 Front Power Seat Position Motor RH (Reclining Position)
- Y 14 Junction Connector
- Y 15 Seat Cushion Climate Control Blower RH
- Y 16 Seat Back Climate Control Blower RH
  
- Z 1 Front Power Seat Switch LH
- Z 2 Front Power Seat Switch LH (Lumbar Support Control)
- Z 3 Front Power Seat Position Motor LH (Slide Position)
- Z 4 Front Power Seat Position Motor LH (Vertical Position)
- Z 5 Front Power Seat Position Motor LH (Lift Position)
- Z 6 Front Power Seat Position Motor LH (Reclining Position)
- Z 7 Front Lumbar Support Motor LH
- Z 8 Front Power Seat Cushion Control Motor LH
- Z 9 Front Power Seat Control ECU and Switch LH
- Z 10 Front Power Seat Control ECU and Switch LH
- Z 11 Front Seat Heater LH
- Z 12 Seat Cushion Climate Control Blower LH
- Z 13 Seat Back Climate Control Blower LH

Position of Parts in Seat <Separate Seat>

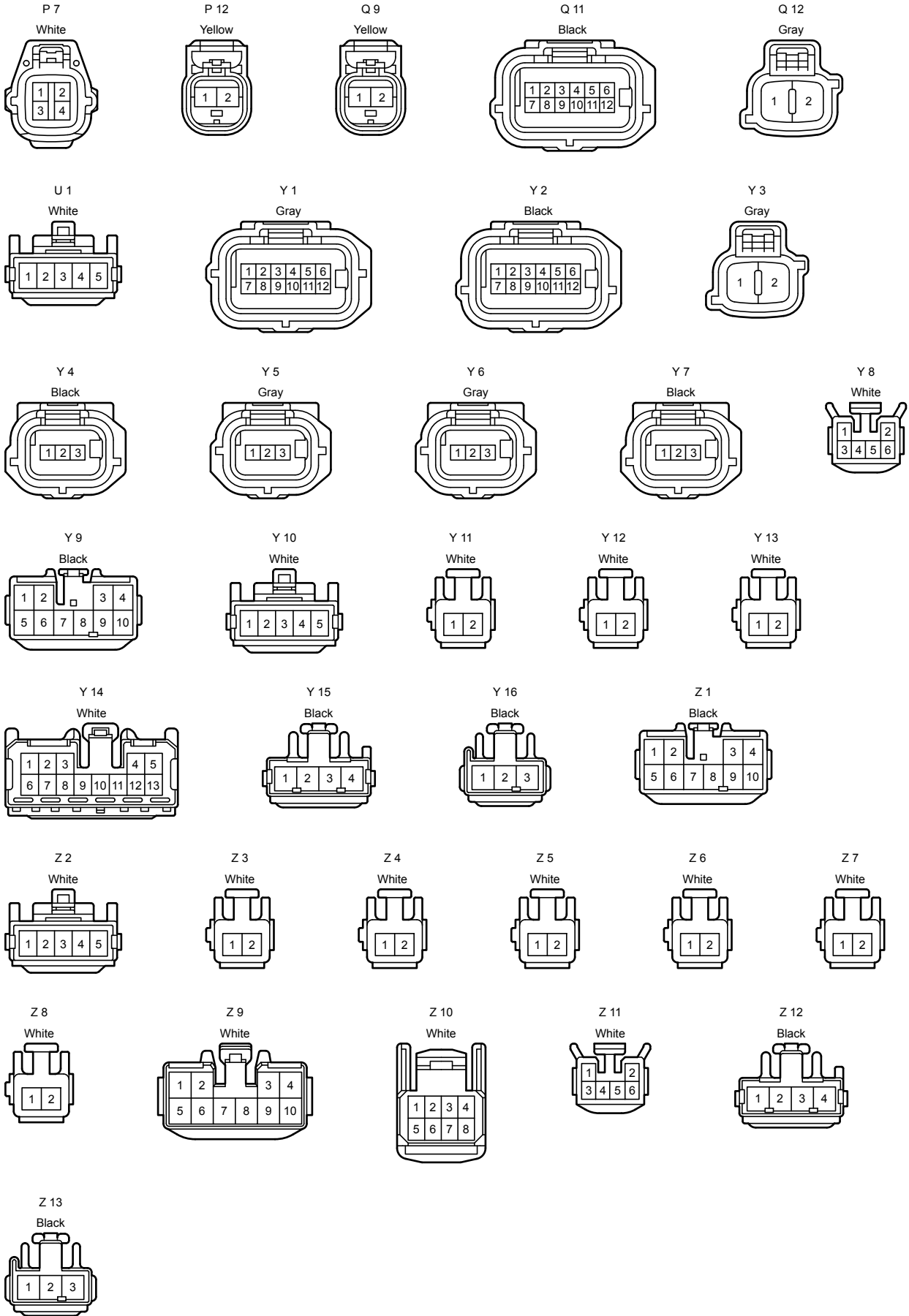



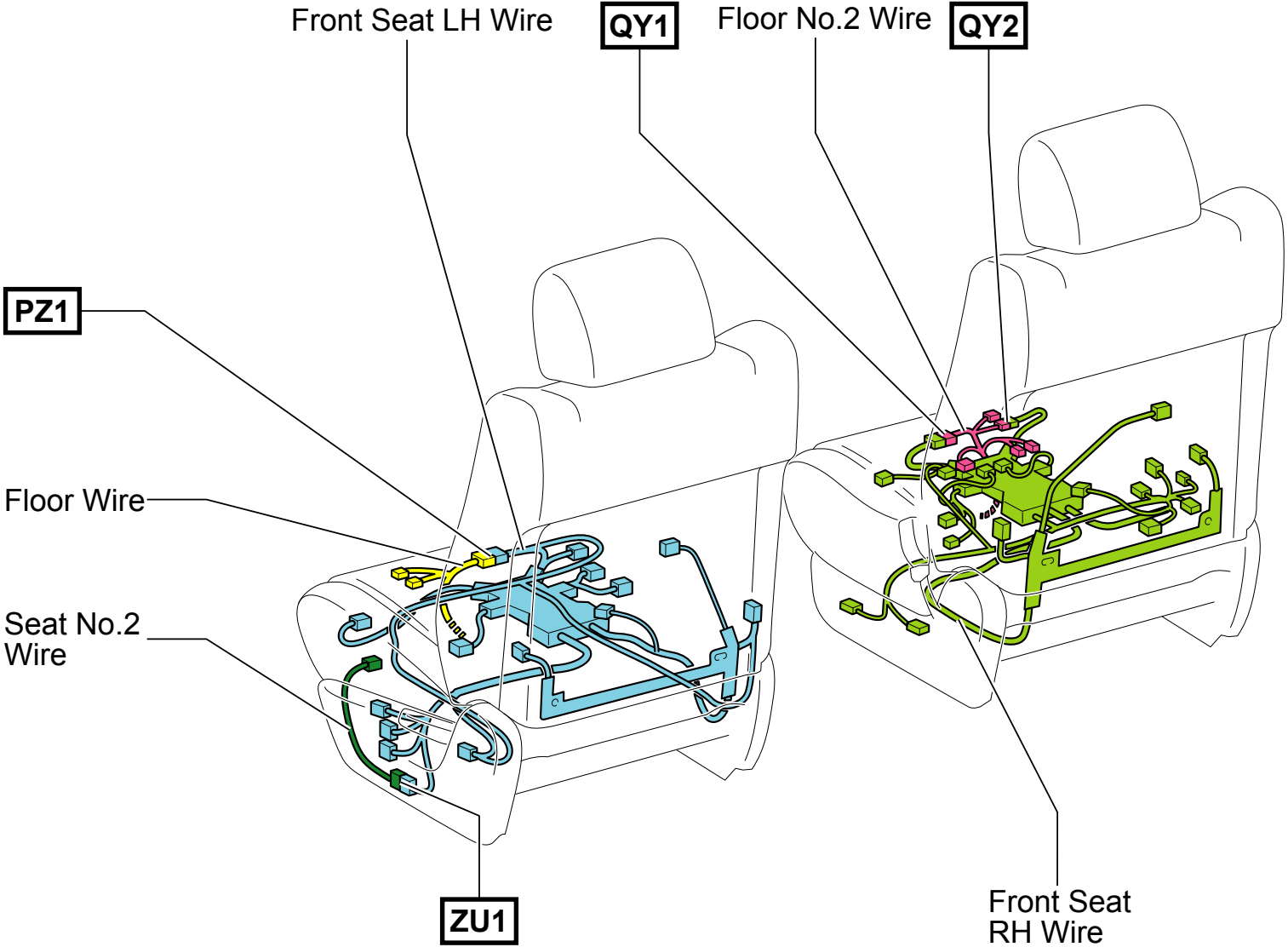

Wire and Wire , Ground Points in Seat <Separate Seat>

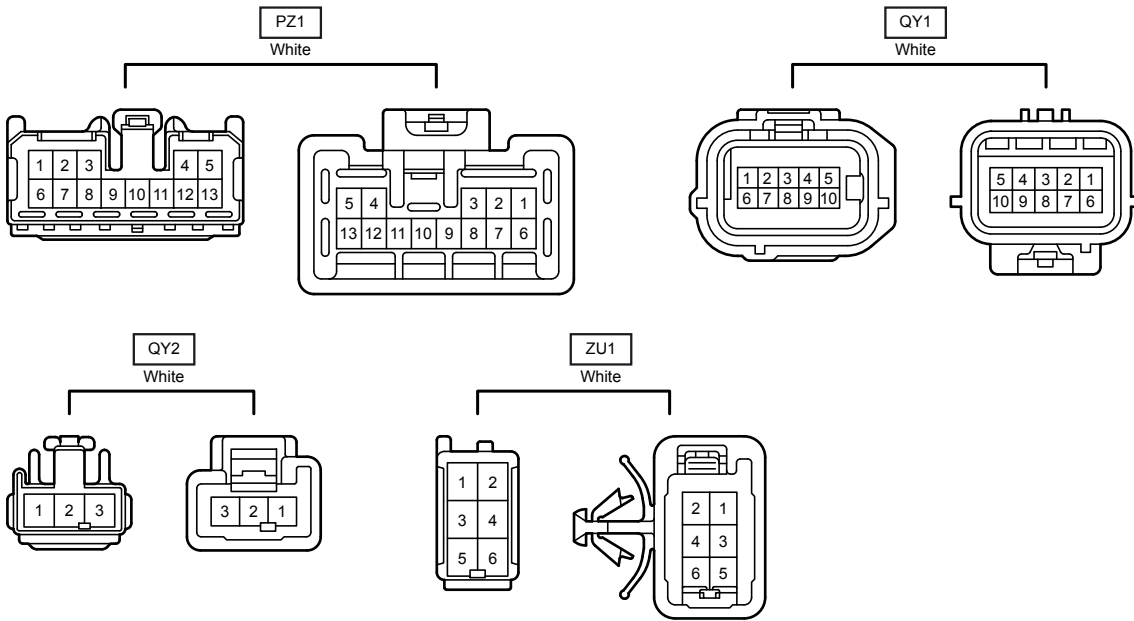

# Fuse List

[Print](#)[Exit](#)[Engine Room R/B and Engine Room J/B](#)

	Fuse	System
5A	ALT-S	<u>Charging</u>
5A	DEF I/UP	<u>Engine Control (1UR-FE)</u> <u>Engine Control (3UR-FE, 3UR-FBE)</u> <u>Rear Window Defogger</u> <u>ABS</u> <u>Accessory Meter</u> <u>Auto LSD</u> <u>Combination Meter</u> <u>Cruise Control (1GR-FE)</u> <u>Cruise Control (1UR-FE)</u> <u>Cruise Control (3UR-FE, 3UR-FBE)</u> <u>Electronically Controlled Transmission and A/T Indicator (1GR-FE)</u> <u>Electronically Controlled Transmission and A/T Indicator (1UR-FE)</u> <u>Electronically Controlled Transmission and A/T Indicator (3UR-FE, 3UR-FBE)</u> <u>Engine Control (1GR-FE)</u> <u>Engine Control (1UR-FE)</u> <u>Engine Control (3UR-FE, 3UR-FBE)</u>
5A	MET-B	<u>Headlight</u> <u>Illumination</u> <u>Interior Light</u> <u>Key Reminder</u> <u>Multi Mode 4WD</u> <u>Power Steering</u> <u>Seat Belt Warning</u> <u>SRS</u> <u>Taillight</u> <u>Theft Deterrent</u> <u>Tire Pressure Warning System</u> <u>TRAC</u> <u>VSC</u> <u>Wireless Door Lock Control</u> <u>Electronically Controlled Transmission and A/T Indicator (1GR-FE)</u> <u>Electronically Controlled Transmission and A/T Indicator (1UR-FE)</u> <u>Electronically Controlled Transmission and A/T Indicator (3UR-FE, 3UR-FBE)</u>
7.5A	AM2	<u>Engine Control (1GR-FE)</u> <u>Engine Control (1UR-FE)</u> <u>Engine Control (3UR-FE, 3UR-FBE)</u> <u>Starting</u>
7.5A	DOME	<u>Accessory Meter</u> <u>Interior Light</u> <u>Theft Deterrent</u> <u>Wireless Door Lock Control</u>
7.5A	ECU-B1	<u>ABS</u> <u>Auto LSD</u> <u>Automatic Glare-Resistant EC Mirror</u> <u>Automatic Light Control</u> <u>Cargo Light</u> <u>Compass</u> <u>Door Lock Control</u> <u>Front Fog Light</u> <u>Garage Door Opener</u> <u>Headlight</u> <u>Headlight Beam Level Control</u> <u>Illumination</u> <u>Interior Light</u>

		<u>Light Auto Turn Off System</u>
		<u>Parking Assist (Rear View Monitor w/o Navigation System)</u>
		<u>Power Seat (Driver's Seat w/ Seat Position Memory)</u>
		<u>Power Steering</u>
		<u>Power Tilt and Power Telescopic</u>
		<u>Power Window</u>
		<u>Sliding Roof</u>
		<u>SRS</u>
		<u>Starting</u>
		<u>Taillight</u>
		<u>Theft Deterrent</u>
		<u>TRAC</u>
		<u>VSC</u>
		<u>Wireless Door Lock Control</u>
7.5A	IMB	<u>Engine Immobiliser System</u>
		<u>ABS</u>
		<u>Accessory Meter</u>
		<u>Auto LSD</u>
		<u>Charging</u>
		<u>Combination Meter</u>
		<u>Cruise Control (1GR-FE)</u>
		<u>Cruise Control (1UR-FE)</u>
		<u>Cruise Control (3UR-FE, 3UR-FBE)</u>
		<u>Electronically Controlled Transmission and A/T Indicator (1GR-FE)</u>
		<u>Electronically Controlled Transmission and A/T Indicator (1UR-FE)</u>
		<u>Electronically Controlled Transmission and A/T Indicator (3UR-FE, 3UR-FBE)</u>
7.5A	MET	<u>Engine Control (1GR-FE)</u>
		<u>Engine Control (1UR-FE)</u>
		<u>Engine Control (3UR-FE, 3UR-FBE)</u>
		<u>Headlight</u>
		<u>Illumination</u>
		<u>Interior Light</u>
		<u>Key Reminder</u>
		<u>Multi Mode 4WD</u>
		<u>Power Steering</u>
		<u>Seat Belt Warning</u>
		<u>SRS</u>
		<u>Taillight</u>
		<u>Tire Pressure Warning System</u>
		<u>TRAC</u>
		<u>VSC</u>
10A	AI PMP HTR	<u>Engine Control (1GR-FE)</u>
10A	EFI NO.2	<u>Engine Control (1GR-FE)</u>
		<u>Engine Control (1UR-FE)</u>
		<u>Engine Control (3UR-FE, 3UR-FBE)</u>
		<u>Cruise Control (1GR-FE)</u>
		<u>Cruise Control (1UR-FE)</u>
		<u>Cruise Control (3UR-FE, 3UR-FBE)</u>
		<u>Electronically Controlled Transmission and A/T Indicator (1GR-FE)</u>
		<u>Electronically Controlled Transmission and A/T Indicator (1UR-FE)</u>
		<u>Electronically Controlled Transmission and A/T Indicator (3UR-FE, 3UR-FBE)</u>
10A	ETCS	<u>Engine Control (1GR-FE)</u>
		<u>Engine Control (1UR-FE)</u>
		<u>Engine Control (3UR-FE, 3UR-FBE)</u>
10A	HORN	<u>Horn</u>
		<u>Theft Deterrent</u>
		<u>Wireless Door Lock Control</u>
10A	IGN	<u>Cruise Control (1GR-FE)</u>
		<u>Cruise Control (1UR-FE)</u>

		<u>Cruise Control (3UR-FE, 3UR-FBE)</u>
		<u>Electronically Controlled Transmission and A/T Indicator (1GR-FE)</u>
		<u>Electronically Controlled Transmission and A/T Indicator (1UR-FE)</u>
		<u>Electronically Controlled Transmission and A/T Indicator (3UR-FE, 3UR-FBE)</u>
		<u>Engine Control (1GR-FE)</u>
		<u>Engine Control (1UR-FE)</u>
		<u>Engine Control (3UR-FE, 3UR-FBE)</u>
		<u>Engine Immobiliser System</u>
		<u>SRS</u>
		<u>Accessory Meter</u>
		<u>Combination Meter</u>
10A	INJ	<u>Engine Control (1GR-FE)</u>
		<u>Engine Control (1UR-FE)</u>
		<u>Engine Control (3UR-FE, 3UR-FBE)</u>
		<u>Ignition (1GR-FE)</u>
		<u>Ignition (1UR-FE)</u>
		<u>Ignition (3UR-FE, 3UR-FBE)</u>
15A	A/F	<u>Engine Control (1GR-FE)</u>
		<u>Engine Control (1UR-FE)</u>
		<u>Engine Control (3UR-FE, 3UR-FBE)</u>
15A	F/PMP	<u>Engine Control (1GR-FE)</u>
		<u>Engine Control (1UR-FE)</u>
		<u>Engine Control (3UR-FE, 3UR-FBE)</u>
15A	FOG	<u>Front Fog Light</u>
15A	HEAD LH	<u>Headlight</u>
15A	HEAD LL	<u>Headlight</u>
15A	HEAD RH	<u>Headlight</u>
15A	HEAD RL	<u>Headlight</u>
		<u>Headlight Beam Level Control</u>
		<u>Audio System (Built-in Type Amplifier)</u>
		<u>Audio System (Separate Type Amplifier)</u>
		<u>Navigation System (Built-in Type Amplifier)</u>
		<u>Navigation System (Separate Type Amplifier)</u>
15A	RAD NO.1	<u>Parking Assist (Rear View Monitor w/ Navigation System) (Built-in Type Amplifier)</u>
		<u>Parking Assist (Rear View Monitor w/ Navigation System) (Separate Type Amplifier)</u>
		<u>ABS</u>
		<u>Auto LSD</u>
		<u>Cruise Control (1GR-FE)</u>
		<u>Cruise Control (1UR-FE)</u>
		<u>Cruise Control (3UR-FE, 3UR-FBE)</u>
		<u>Electronically Controlled Transmission and A/T Indicator (1GR-FE)</u>
		<u>Electronically Controlled Transmission and A/T Indicator (1UR-FE)</u>
		<u>Electronically Controlled Transmission and A/T Indicator (3UR-FE, 3UR-FBE)</u>
15A	STOP	<u>Engine Control (1GR-FE)</u>
		<u>Engine Control (1UR-FE)</u>
		<u>Engine Control (3UR-FE, 3UR-FBE)</u>
		<u>Shift Lock (Column Shift)</u>
		<u>Shift Lock (Floor Shift)</u>
		<u>Stop Light</u>
		<u>TRAC</u>
		<u>Trailer Towing</u>
		<u>VSC</u>
15A	TURN-HAZ	<u>Headlight</u>
		<u>Turn Signal and Hazard Warning Light</u>
		<u>Front Window Deicer</u>

20A	DEICER	<u>Cruise Control (1GR-FE)</u> <u>Cruise Control (1UR-FE)</u> <u>Cruise Control (3UR-FE, 3UR-FBE)</u>
25A	EFI NO.1	<u>Electronically Controlled Transmission and A/T Indicator (1GR-FE)</u> <u>Electronically Controlled Transmission and A/T Indicator (1UR-FE)</u> <u>Electronically Controlled Transmission and A/T Indicator (3UR-FE, 3UR-FBE)</u> <u>Engine Control (1GR-FE)</u> <u>Engine Control (1UR-FE)</u> <u>Engine Control (3UR-FE, 3UR-FBE)</u>
25A	POWER NO.4	<u>Power Window</u>
30A	AMP	<u>Audio System (Separate Type Amplifier)</u> <u>Navigation System (Separate Type Amplifier)</u> <u>Parking Assist (Rear View Monitor w/ Navigation System) (Separate Type Amplifier)</u>
30A	POWER NO.2	<u>Power Window</u>
30A	ST	<u>Starting</u>
30A	TOW BRK	<u>Trailer Towing</u>
30A	TOW TAIL	<u>Trailer Towing</u>
30A	TOWING	<u>Trailer Towing</u>
40A	ABS2	<u>ABS</u> <u>Auto LSD</u> <u>TRAC</u> <u>VSC</u>
40A	DEFOG	<u>Engine Control (1UR-FE)</u> <u>Engine Control (3UR-FE, 3UR-FBE)</u> <u>Rear Window Defogger</u> <u>Automatic Light Control</u> <u>Headlight</u>
40A	MAIN	<u>Headlight Beam Level Control</u> <u>Light Auto Turn Off System</u> <u>Theft Deterrent</u> <u>Wireless Door Lock Control</u>
40A	SUB BATT	<u>Trailer Towing</u>
50A	A/PUMP NO.1	<u>Engine Control (1GR-FE)</u> <u>Engine Control (1UR-FE)</u> <u>Engine Control (3UR-FE, 3UR-FBE)</u>
50A	A/PUMP NO.2	<u>Engine Control (1UR-FE)</u> <u>Engine Control (3UR-FE, 3UR-FBE)</u>
50A	ABS1	<u>ABS</u> <u>Auto LSD</u> <u>TRAC</u> <u>VSC</u>
50A	HTR	<u>Air Conditioning</u> <u>Automatic Light Control</u> <u>Charging</u> <u>Illumination</u>
140A	ALT (1GR-FE)	<u>Light Auto Turn Off System</u> <u>Parking Assist (Intuitive Parking Assist)</u> <u>Power Outlet (12V)</u> <u>Taillight</u> <u>Wireless Door Lock Control</u>

150A LH-J/B

Automatic Light Control  
Front Fog Light  
Illumination  
Light Auto Turn Off System  
Parking Assist (Intuitive Parking Assist)  
Power Outlet (12V)  
Taillight  
Theft Deterrent  
Trailer Towing  
Wireless Door Lock Control

180A ALT (3UR-FE, 3UR-FBE,  
1UR-FE)

Charging

© 2012 TOYOTA MOTOR CORPORATION. All Rights Reserved.



**Print**

Driver Side J/B

Fuse	System
7.5A A/C	<u>Air Conditioning</u> <u>Accessory Meter</u> <u>Audio System (Built-in Type Amplifier)</u> <u>Audio System (Separate Type Amplifier)</u> <u>Automatic Light Control</u> <u>Back-Up Light</u> <u>Cargo Light</u> <u>Cruise Control (1GR-FE)</u> <u>Cruise Control (1UR-FE)</u> <u>Cruise Control (3UR-FE, 3UR-FBE)</u> <u>Door Lock Control</u> <u>Electronically Controlled Transmission and A/T Indicator (1GR-FE)</u> <u>Electronically Controlled Transmission and A/T Indicator (1UR-FE)</u> <u>Electronically Controlled Transmission and A/T Indicator (3UR-FE, 3UR-FBE)</u> <u>Front Fog Light</u> <u>Headlight</u> <u>Headlight Beam Level Control</u> <u>Illumination</u>
7.5A ACC	<u>Interior Light</u> <u>Light Auto Turn Off System</u> <u>Navigation System (Built-in Type Amplifier)</u> <u>Navigation System (Separate Type Amplifier)</u> <u>Parking Assist (Intuitive Parking Assist)</u> <u>Parking Assist (Rear View Monitor w/ Navigation System) (Built-in Type Amplifier)</u> <u>Parking Assist (Rear View Monitor w/ Navigation System) (Separate Type Amplifier)</u> <u>Parking Assist (Rear View Monitor w/o Navigation System)</u> <u>Power Window</u> <u>Remote Control Mirror (w/ Seat Position Memory)</u> <u>Remote Control Mirror (w/o Seat Position Memory)</u> <u>Sliding Roof</u> <u>Taillight</u> <u>Theft Deterrent</u> <u>Trailer Towing</u> <u>Wireless Door Lock Control</u>
7.5A AM1	<u>Power Outlet (12V)</u> <u>Shift Lock (Column Shift)</u> <u>Shift Lock (Floor Shift)</u> <u>Starting</u>
7.5A CARGO LP	<u>Cargo Light</u>
7.5A ECU-IG No.1	<u>ABS</u> <u>Accessory Meter</u> <u>Air Conditioning</u> <u>Auto LSD</u> <u>Automatic Glare-Resistant EC Mirror</u> <u>Compass</u> <u>Front Window Deicer</u> <u>Key Reminder</u> <u>Mirror Heater</u> <u>Parking Assist (Intuitive Parking Assist)</u> <u>Parking Assist (Rear View Monitor w/o Navigation System)</u> <u>Power Outlet (115V)</u> <u>Power Seat (Driver's Seat w/ Seat Position Memory)</u> <u>Power Steering</u> <u>Power Tilt and Power Telescopic</u> <u>Rear Window Defogger</u>

	<u>Seat Belt Warning</u>
	<u>Shift Lock (Column Shift)</u>
	<u>Shift Lock (Floor Shift)</u>
	<u>Sliding Roof</u>
	<u>Stop Light</u>
	<u>Theft Deterrent</u>
	<u>Tire Pressure Warning System</u>
	<u>TRAC</u>
	<u>Trailer Towing</u>
	<u>VSC</u>
	<u>Automatic Light Control</u>
	<u>Cargo Light</u>
	<u>Door Lock Control</u>
	<u>Front Fog Light</u>
	<u>Headlight</u>
	<u>Headlight Beam Level Control</u>
	<u>Illumination</u>
7.5A ECU-IG No.2	<u>Interior Light</u>
	<u>Light Auto Turn Off System</u>
	<u>Power Steering</u>
	<u>Power Window</u>
	<u>Sliding Roof</u>
	<u>Taillight</u>
	<u>Theft Deterrent</u>
	<u>Wireless Door Lock Control</u>
	<u>Audio System (Built-in Type Amplifier)</u>
	<u>Audio System (Separate Type Amplifier)</u>
	<u>Back-Up Light</u>
	<u>Charging</u>
	<u>Climate Control Seat</u>
	<u>Cruise Control (1GR-FE)</u>
	<u>Cruise Control (1UR-FE)</u>
	<u>Cruise Control (3UR-FE, 3UR-FBE)</u>
	<u>Door Lock Control</u>
	<u>Electronically Controlled Transmission and A/T Indicator (1GR-FE)</u>
	<u>Electronically Controlled Transmission and A/T Indicator (1UR-FE)</u>
	<u>Electronically Controlled Transmission and A/T Indicator (3UR-FE, 3UR-FBE)</u>
	<u>Front Window Deicer</u>
7.5A LH-IG	<u>Headlight</u>
	<u>Mirror Heater</u>
	<u>Navigation System (Built-in Type Amplifier)</u>
	<u>Navigation System (Separate Type Amplifier)</u>
	<u>Parking Assist (Intuitive Parking Assist)</u>
	<u>Parking Assist (Rear View Monitor w/ Navigation System) (Built-in Type Amplifier)</u>
	<u>Parking Assist (Rear View Monitor w/ Navigation System) (Separate Type Amplifier)</u>
	<u>Rear Window Defogger</u>
	<u>Seat Heater (w/ Climate Control Seat)</u>
	<u>Seat Heater (w/o Climate Control Seat)</u>
	<u>Trailer Towing</u>
	<u>Turn Signal and Hazard Warning Light</u>
7.5A OBD	<u>Data Link Connector 3</u>
7.5A PANEL	<u>Illumination</u>
	<u>Parking Assist (Intuitive Parking Assist)</u>
7.5A TOW BK/UP	<u>Trailer Towing</u>
10A A/C IG	<u>Air Conditioning</u>
10A BK/UP LP	<u>Audio System (Built-in Type Amplifier)</u>
	<u>Audio System (Separate Type Amplifier)</u>
	<u>Back-Up Light</u>
	<u>Cruise Control (1GR-FE)</u>

		<u>Cruise Control (1UR-FE)</u>
		<u>Cruise Control (3UR-FE, 3UR-FBE)</u>
		<u>Door Lock Control</u>
		<u>Electronically Controlled Transmission and A/T Indicator (1GR-FE)</u>
		<u>Electronically Controlled Transmission and A/T Indicator (1UR-FE)</u>
		<u>Electronically Controlled Transmission and A/T Indicator (3UR-FE, 3UR-FBE)</u>
		<u>Navigation System (Built-in Type Amplifier)</u>
		<u>Navigation System (Separate Type Amplifier)</u>
		<u>Parking Assist (Intuitive Parking Assist)</u>
		<u>Parking Assist (Rear View Monitor w/ Navigation System) (Built-in Type Amplifier)</u>
		<u>Parking Assist (Rear View Monitor w/ Navigation System) (Separate Type Amplifier)</u>
		<u>Parking Assist (Rear View Monitor w/o Navigation System)</u>
		<u>Power Seat (Driver's Seat w/ Seat Position Memory)</u>
		<u>Power Tilt and Power Telescopic</u>
		<u>Remote Control Mirror (w/ Seat Position Memory)</u>
		<u>Trailer Towing</u>
15A	INVERTER	<u>Power Outlet (115V)</u>
15A	MIR	<u>Interior Light</u> <u>Mirror Heater</u> <u>Remote Control Mirror (w/ Seat Position Memory)</u>
15A	PWR OUTLET	<u>Power Outlet (12V)</u>
15A	TAIL	<u>Front Fog Light</u> <u>Taillight</u> <u>Trailer Towing</u>
15A	TI&TE	<u>Power Tilt and Power Telescopic</u>
20A	4WD	<u>Multi Mode 4WD</u>
20A	POWER No.3	<u>Door Lock Control</u> <u>Power Window</u>
20A	SEAT-HTR	<u>Climate Control Seat</u> <u>Seat Heater (w/ Climate Control Seat)</u> <u>Seat Heater (w/o Climate Control Seat)</u>
20A	WSH	<u>Front Wiper and Washer (w/ Intermittent Wiper)</u> <u>Front Wiper and Washer (w/o Intermittent Wiper)</u> <u>Automatic Light Control</u> <u>Cargo Light</u> <u>Door Lock Control</u> <u>Front Fog Light</u> <u>Headlight</u> <u>Headlight Beam Level Control</u>
25A	DR/LCK	<u>Illumination</u> <u>Interior Light</u> <u>Light Auto Turn Off System</u> <u>Power Window</u> <u>Sliding Roof</u> <u>Taillight</u> <u>Theft Deterrent</u> <u>Wireless Door Lock Control</u>
25A	S/ROOF	<u>Sliding Roof</u>
30A	FR P/SEAT LH	<u>Power Seat (Driver's Seat w/ Seat Position Memory)</u> <u>Power Seat (Driver's Seat w/o Seat Position Memory)</u>
30A	FR P/SEAT RH	<u>Power Seat (Front Passenger's Seat)</u>
30A	POWER No.1	<u>Power Window</u>

30A WIPER

Front Wiper and Washer (w/ Intermittent Wiper).  
Front Wiper and Washer (w/o Intermittent Wiper).

© 2012 TOYOTA MOTOR CORPORATION. All Rights Reserved.

**Print**

Driver Side J/B

Fuse	System
7.5A A/C	<u>Air Conditioning</u> <u>Accessory Meter</u> <u>Audio System (Built-in Type Amplifier)</u> <u>Audio System (Separate Type Amplifier)</u> <u>Automatic Light Control</u> <u>Back-Up Light</u> <u>Cargo Light</u> <u>Cruise Control (1GR-FE)</u> <u>Cruise Control (1UR-FE)</u> <u>Cruise Control (3UR-FE, 3UR-FBE)</u> <u>Door Lock Control</u> <u>Electronically Controlled Transmission and A/T Indicator (1GR-FE)</u> <u>Electronically Controlled Transmission and A/T Indicator (1UR-FE)</u> <u>Electronically Controlled Transmission and A/T Indicator (3UR-FE, 3UR-FBE)</u> <u>Front Fog Light</u> <u>Headlight</u> <u>Headlight Beam Level Control</u> <u>Illumination</u>
7.5A ACC	<u>Interior Light</u> <u>Light Auto Turn Off System</u> <u>Navigation System (Built-in Type Amplifier)</u> <u>Navigation System (Separate Type Amplifier)</u> <u>Parking Assist (Intuitive Parking Assist)</u> <u>Parking Assist (Rear View Monitor w/ Navigation System) (Built-in Type Amplifier)</u> <u>Parking Assist (Rear View Monitor w/ Navigation System) (Separate Type Amplifier)</u> <u>Parking Assist (Rear View Monitor w/o Navigation System)</u> <u>Power Window</u> <u>Remote Control Mirror (w/ Seat Position Memory)</u> <u>Remote Control Mirror (w/o Seat Position Memory)</u> <u>Sliding Roof</u> <u>Taillight</u> <u>Theft Deterrent</u> <u>Trailer Towing</u> <u>Wireless Door Lock Control</u>
7.5A AM1	<u>Power Outlet (12V)</u> <u>Shift Lock (Column Shift)</u> <u>Shift Lock (Floor Shift)</u> <u>Starting</u>
7.5A CARGO LP	<u>Cargo Light</u>
7.5A ECU-IG No.1	<u>ABS</u> <u>Accessory Meter</u> <u>Air Conditioning</u> <u>Auto LSD</u> <u>Automatic Glare-Resistant EC Mirror</u> <u>Compass</u> <u>Front Window Deicer</u> <u>Key Reminder</u> <u>Mirror Heater</u> <u>Parking Assist (Intuitive Parking Assist)</u> <u>Parking Assist (Rear View Monitor w/o Navigation System)</u> <u>Power Outlet (115V)</u> <u>Power Seat (Driver's Seat w/ Seat Position Memory)</u> <u>Power Steering</u> <u>Power Tilt and Power Telescopic</u> <u>Rear Window Defogger</u>

	<u>Seat Belt Warning</u>
	<u>Shift Lock (Column Shift)</u>
	<u>Shift Lock (Floor Shift)</u>
	<u>Sliding Roof</u>
	<u>Stop Light</u>
	<u>Theft Deterrent</u>
	<u>Tire Pressure Warning System</u>
	<u>TRAC</u>
	<u>Trailer Towing</u>
	<u>VSC</u>
	<u>Automatic Light Control</u>
	<u>Cargo Light</u>
	<u>Door Lock Control</u>
	<u>Front Fog Light</u>
	<u>Headlight</u>
	<u>Headlight Beam Level Control</u>
	<u>Illumination</u>
7.5A ECU-IG No.2	<u>Interior Light</u>
	<u>Light Auto Turn Off System</u>
	<u>Power Steering</u>
	<u>Power Window</u>
	<u>Sliding Roof</u>
	<u>Taillight</u>
	<u>Theft Deterrent</u>
	<u>Wireless Door Lock Control</u>
	<u>Audio System (Built-in Type Amplifier)</u>
	<u>Audio System (Separate Type Amplifier)</u>
	<u>Back-Up Light</u>
	<u>Charging</u>
	<u>Climate Control Seat</u>
	<u>Cruise Control (1GR-FE)</u>
	<u>Cruise Control (1UR-FE)</u>
	<u>Cruise Control (3UR-FE, 3UR-FBE)</u>
	<u>Door Lock Control</u>
	<u>Electronically Controlled Transmission and A/T Indicator (1GR-FE)</u>
	<u>Electronically Controlled Transmission and A/T Indicator (1UR-FE)</u>
	<u>Electronically Controlled Transmission and A/T Indicator (3UR-FE, 3UR-FBE)</u>
	<u>Front Window Deicer</u>
7.5A LH-IG	<u>Headlight</u>
	<u>Mirror Heater</u>
	<u>Navigation System (Built-in Type Amplifier)</u>
	<u>Navigation System (Separate Type Amplifier)</u>
	<u>Parking Assist (Intuitive Parking Assist)</u>
	<u>Parking Assist (Rear View Monitor w/ Navigation System) (Built-in Type Amplifier)</u>
	<u>Parking Assist (Rear View Monitor w/ Navigation System) (Separate Type Amplifier)</u>
	<u>Rear Window Defogger</u>
	<u>Seat Heater (w/ Climate Control Seat)</u>
	<u>Seat Heater (w/o Climate Control Seat)</u>
	<u>Trailer Towing</u>
	<u>Turn Signal and Hazard Warning Light</u>
7.5A OBD	<u>Data Link Connector 3</u>
7.5A PANEL	<u>Illumination</u>
	<u>Parking Assist (Intuitive Parking Assist)</u>
7.5A TOW BK/UP	<u>Trailer Towing</u>
10A A/C IG	<u>Air Conditioning</u>
10A BK/UP LP	<u>Audio System (Built-in Type Amplifier)</u>
	<u>Audio System (Separate Type Amplifier)</u>
	<u>Back-Up Light</u>
	<u>Cruise Control (1GR-FE)</u>

		<u>Cruise Control (1UR-FE)</u>
		<u>Cruise Control (3UR-FE, 3UR-FBE)</u>
		<u>Door Lock Control</u>
		<u>Electronically Controlled Transmission and A/T Indicator (1GR-FE)</u>
		<u>Electronically Controlled Transmission and A/T Indicator (1UR-FE)</u>
		<u>Electronically Controlled Transmission and A/T Indicator (3UR-FE, 3UR-FBE)</u>
		<u>Navigation System (Built-in Type Amplifier)</u>
		<u>Navigation System (Separate Type Amplifier)</u>
		<u>Parking Assist (Intuitive Parking Assist)</u>
		<u>Parking Assist (Rear View Monitor w/ Navigation System) (Built-in Type Amplifier)</u>
		<u>Parking Assist (Rear View Monitor w/ Navigation System) (Separate Type Amplifier)</u>
		<u>Parking Assist (Rear View Monitor w/o Navigation System)</u>
		<u>Power Seat (Driver's Seat w/ Seat Position Memory)</u>
		<u>Power Tilt and Power Telescopic</u>
		<u>Remote Control Mirror (w/ Seat Position Memory)</u>
		<u>Trailer Towing</u>
15A	INVERTER	<u>Power Outlet (115V)</u>
15A	MIR	<u>Interior Light</u> <u>Mirror Heater</u> <u>Remote Control Mirror (w/ Seat Position Memory)</u>
15A	PWR OUTLET	<u>Power Outlet (12V)</u>
15A	TAIL	<u>Front Fog Light</u> <u>Taillight</u> <u>Trailer Towing</u>
15A	TI&TE	<u>Power Tilt and Power Telescopic</u>
20A	4WD	<u>Multi Mode 4WD</u>
20A	POWER No.3	<u>Door Lock Control</u> <u>Power Window</u>
20A	SEAT-HTR	<u>Climate Control Seat</u> <u>Seat Heater (w/ Climate Control Seat)</u> <u>Seat Heater (w/o Climate Control Seat)</u>
20A	WSH	<u>Front Wiper and Washer (w/ Intermittent Wiper)</u> <u>Front Wiper and Washer (w/o Intermittent Wiper)</u> <u>Automatic Light Control</u> <u>Cargo Light</u> <u>Door Lock Control</u> <u>Front Fog Light</u> <u>Headlight</u> <u>Headlight Beam Level Control</u>
25A	DR/LCK	<u>Illumination</u> <u>Interior Light</u> <u>Light Auto Turn Off System</u> <u>Power Window</u> <u>Sliding Roof</u> <u>Taillight</u> <u>Theft Deterrent</u> <u>Wireless Door Lock Control</u>
25A	S/ROOF	<u>Sliding Roof</u>
30A	FR P/SEAT LH	<u>Power Seat (Driver's Seat w/ Seat Position Memory)</u> <u>Power Seat (Driver's Seat w/o Seat Position Memory)</u>
30A	FR P/SEAT RH	<u>Power Seat (Front Passenger's Seat)</u>
30A	POWER No.1	<u>Power Window</u>

Front Wiper and Washer (w/ Intermittent Wiper).  
Front Wiper and Washer (w/o Intermittent Wiper).

© 2012 TOYOTA MOTOR CORPORATION. All Rights Reserved.



# Overall EWD

TOYOTA TUNDRA (EM16G1U)

1 TOYOTA TUNDRA

(Cont. next page)

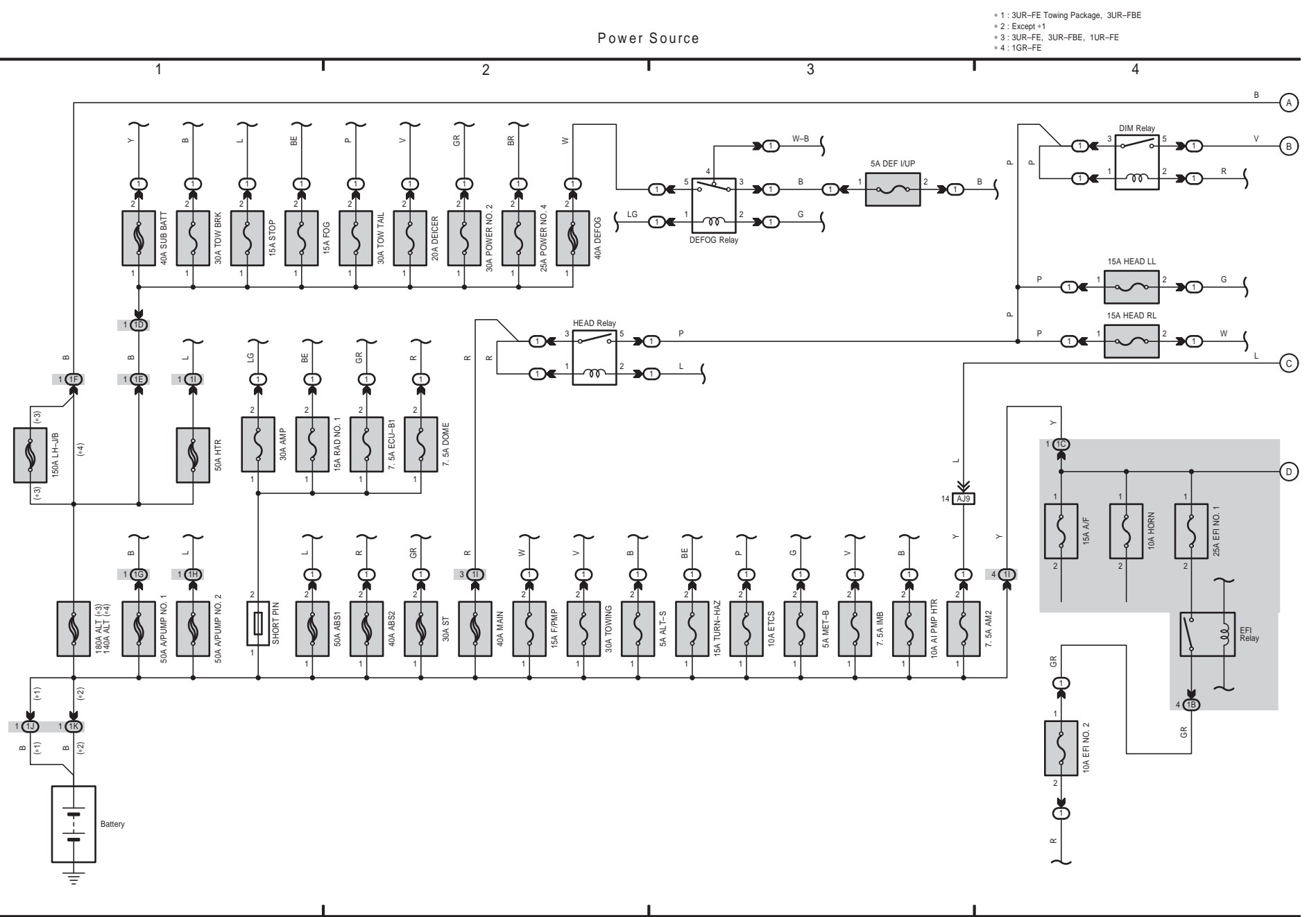

M OVERALL ELECTRICAL WIRING DIAGRAM

1 TOYOTA TUNDRA (Cont' d)

Power Source

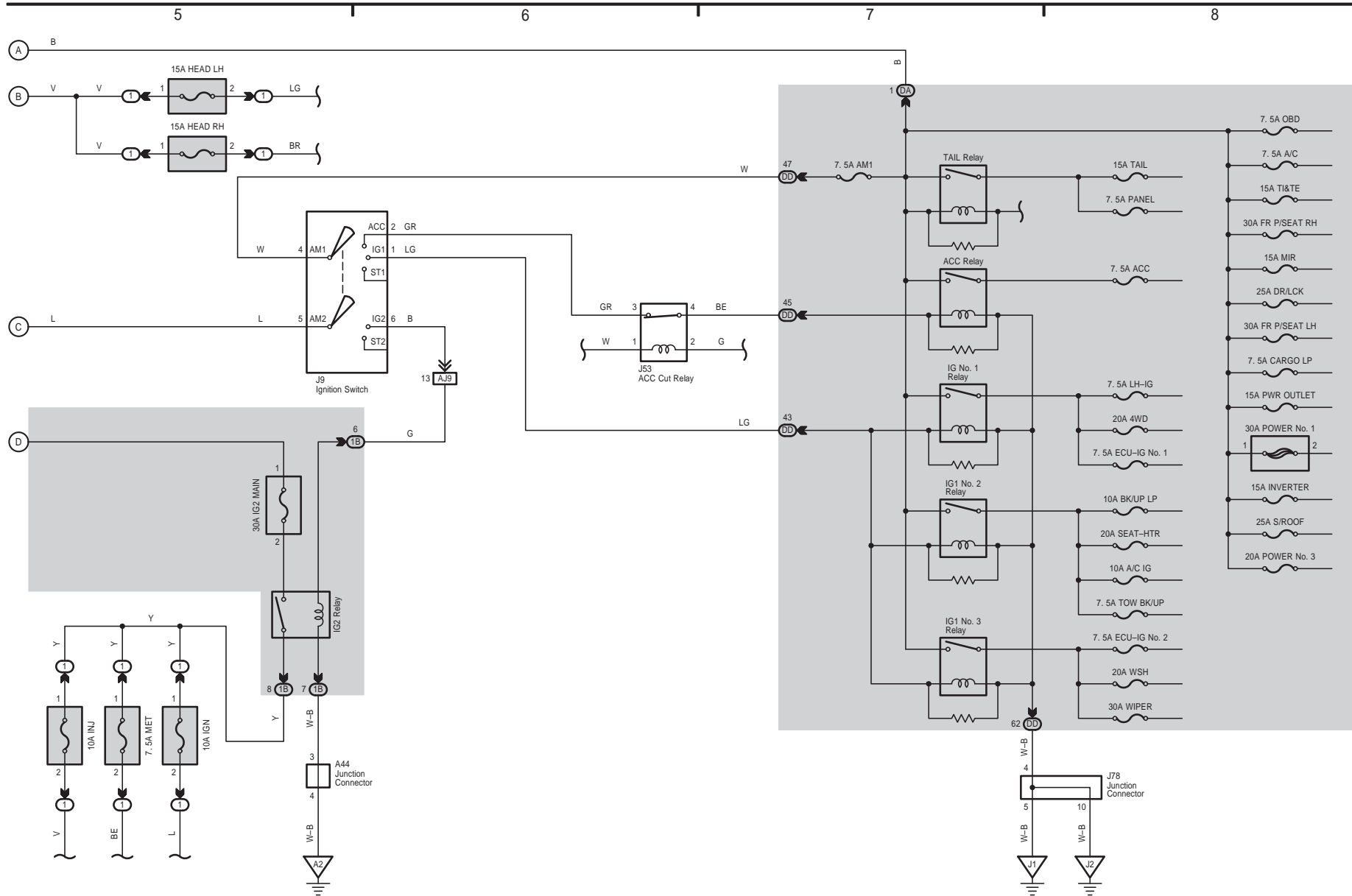

TOYOTA TUNDRA (EM16G1U)

Multiplex Communication System (CAN)

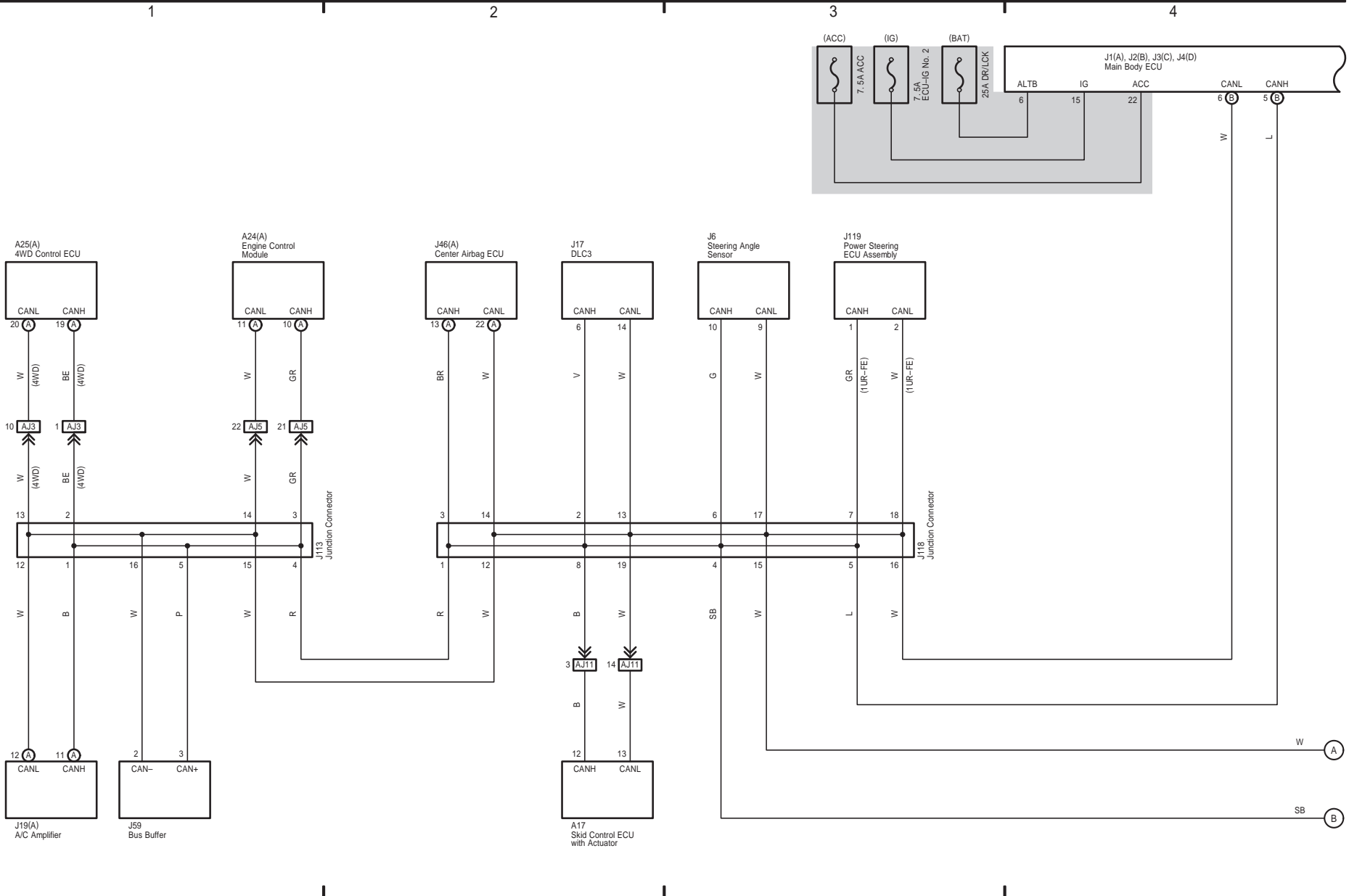

TOYOTA TUNDRA (EM16G1U)

M OVERALL ELECTRICAL WIRING DIAGRAM

Multiplex Communication System (CAN)

- \* 1 : w/ Seat Position Memory
- \*14 : Except Optitron Meter
- \*15 : w/ Daytime Running Light

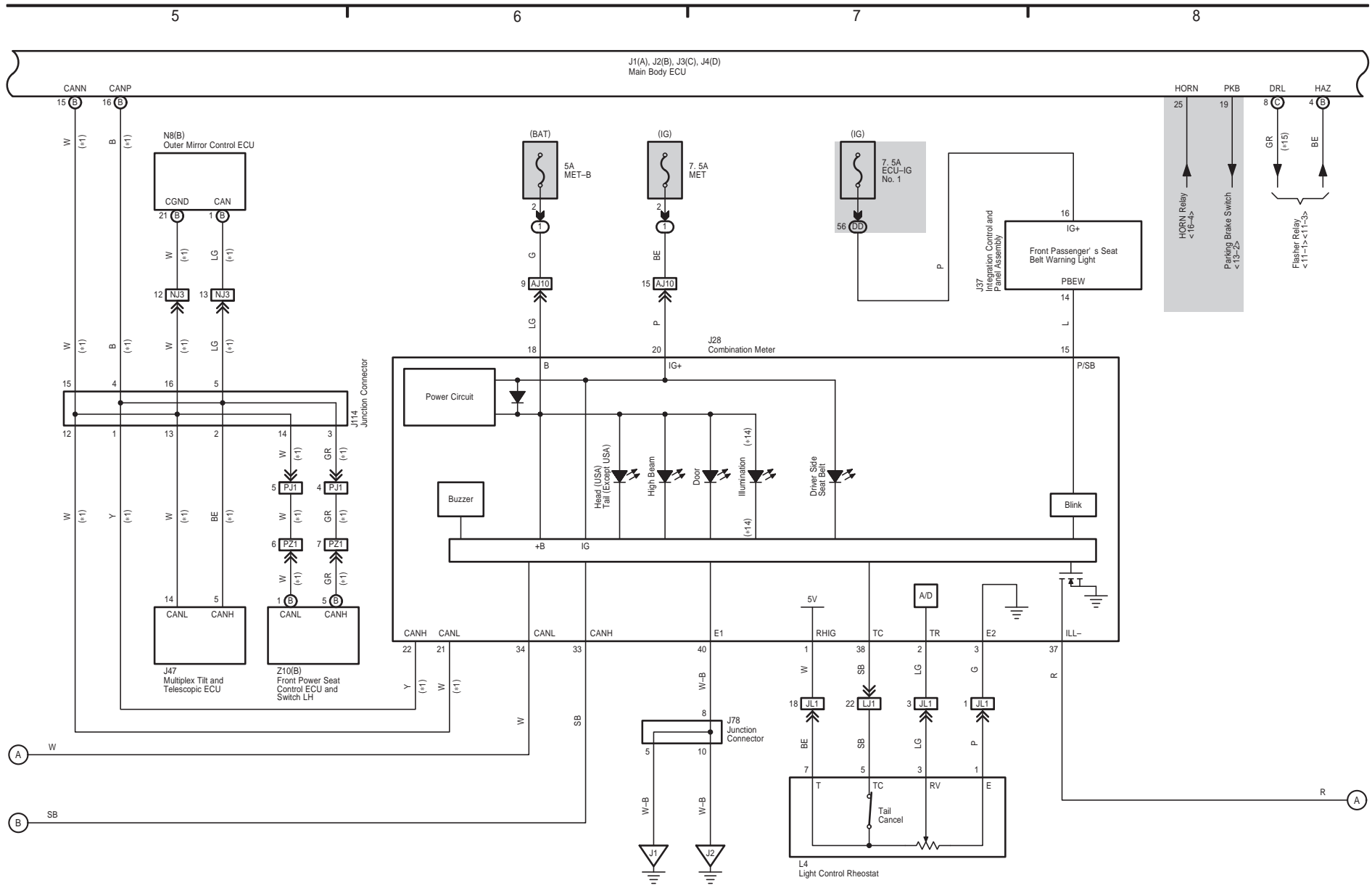

TOYOTA TUNDRA (EM16G1U)

Multiplex Communication System (CAN)

\* 1 : w/ Seat Position Memory

9

10

11

12

J1(A), J2(B), J3(C), J4(D)  
Main Body ECU

TOYOTA TUNDRA (EM16G1U)

M OVERALL ELECTRICAL WIRING DIAGRAM

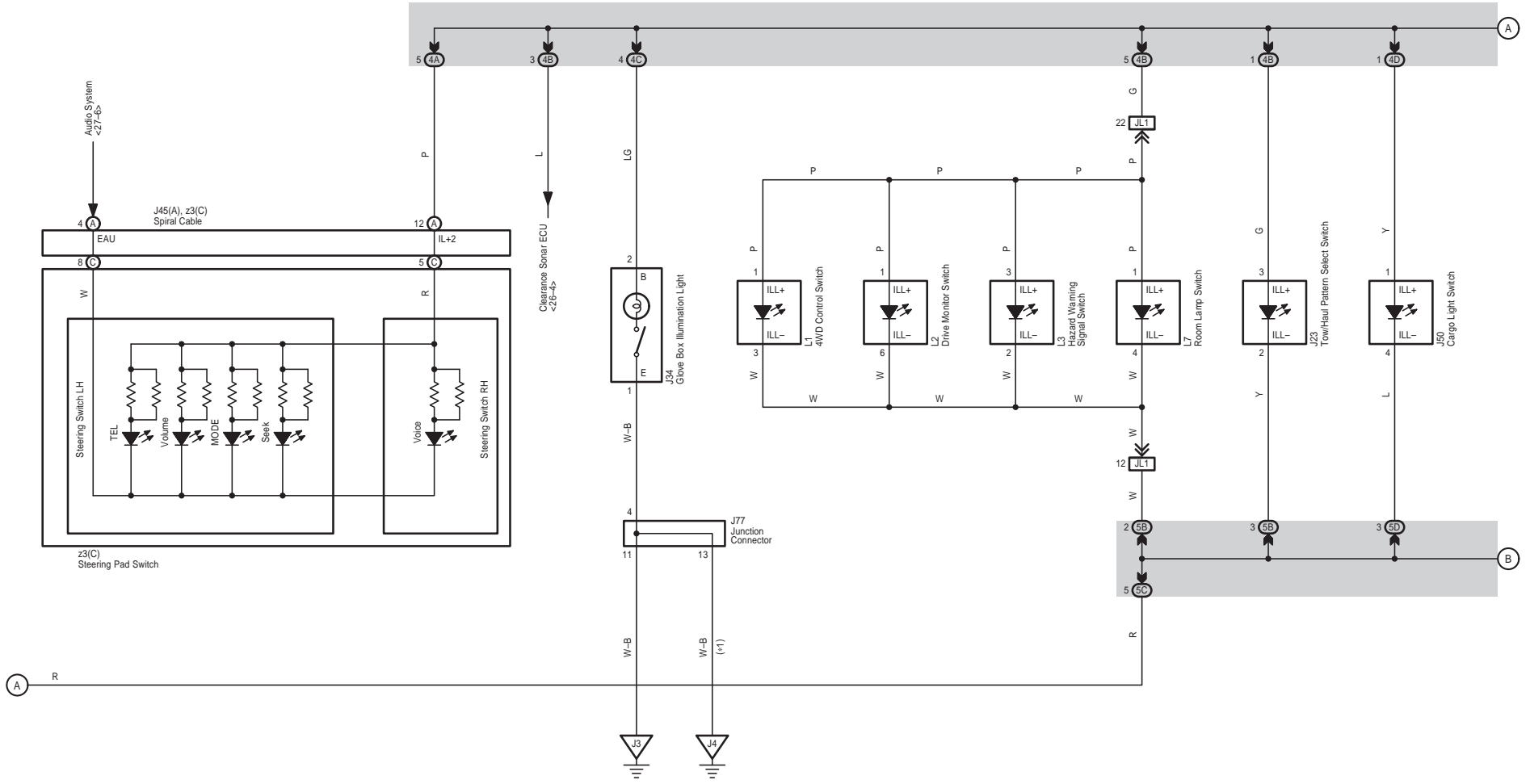

Multiplex Communication System (CAN)

13

14

15

16

J1(A), J2(B), J3(C), J4(D)  
Main Body ECU

TRLY

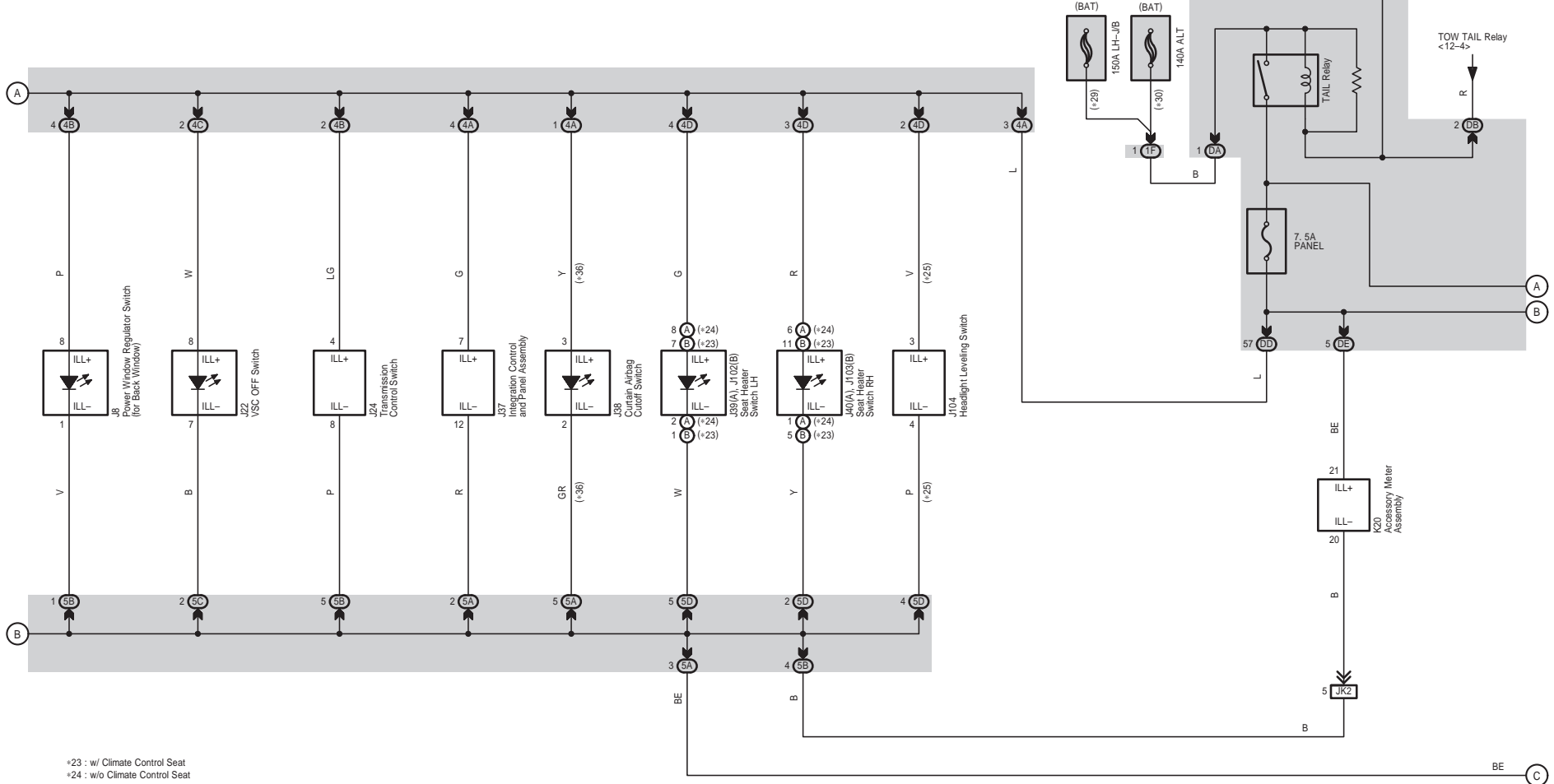

- \*23 : w/ Climate Control Seat
- \*24 : w/o Climate Control Seat
- \*25 : w/ Headlight Leveling
- \*29 : 3UR-FE, 3UR-FBE, 1UR-FE
- \*30 : 1GR-FE
- \*36 : w/ Curtain Airbag Cutoff Switch

Multiplex Communication System (CAN)

- \* 2 : Separate Type Amplifier
- \* 3 : Built-in Type Amplifier
- \* 4 : w/ Navigation System
- \* 5 : w/o Navigation System

TOYOTA TUNDRA (EM16G1U)

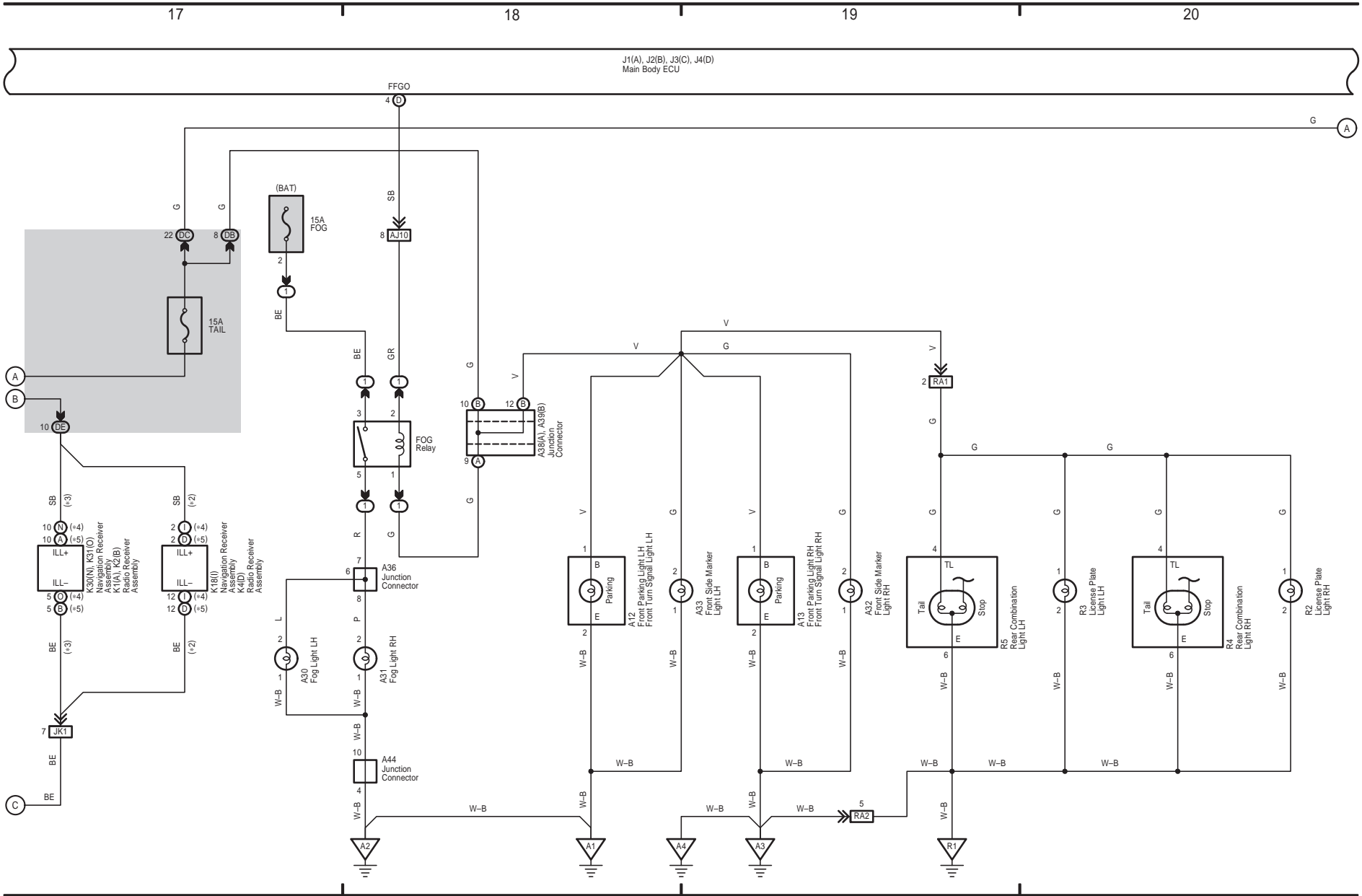



Multiplex Communication System (CAN)

\* 1 : w/ Seat Position Memory

21

22

23

24

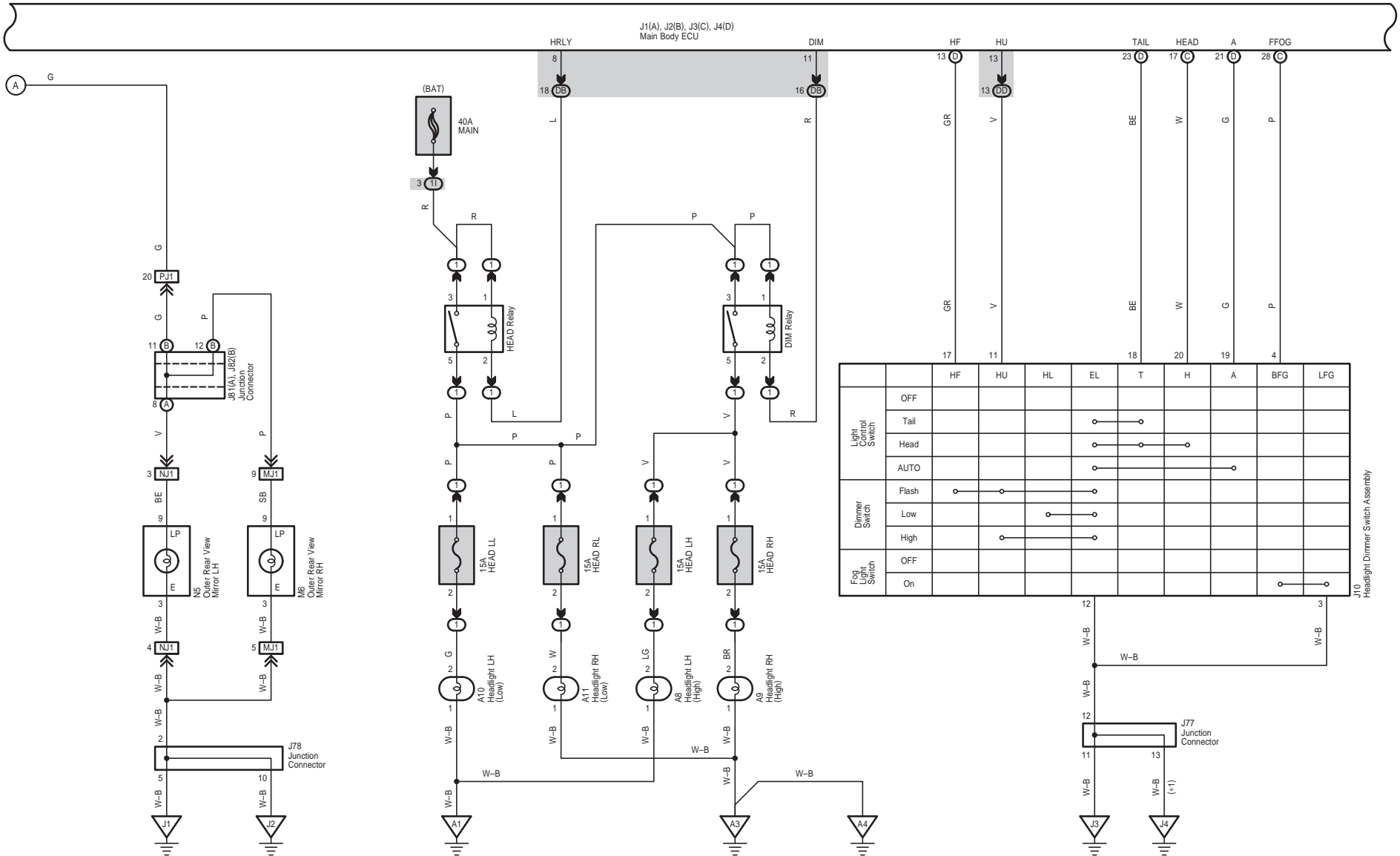

TOYOTA TUNDRA (EM16G1U)

Multiplex Communication System (CAN)

25

26

27

28

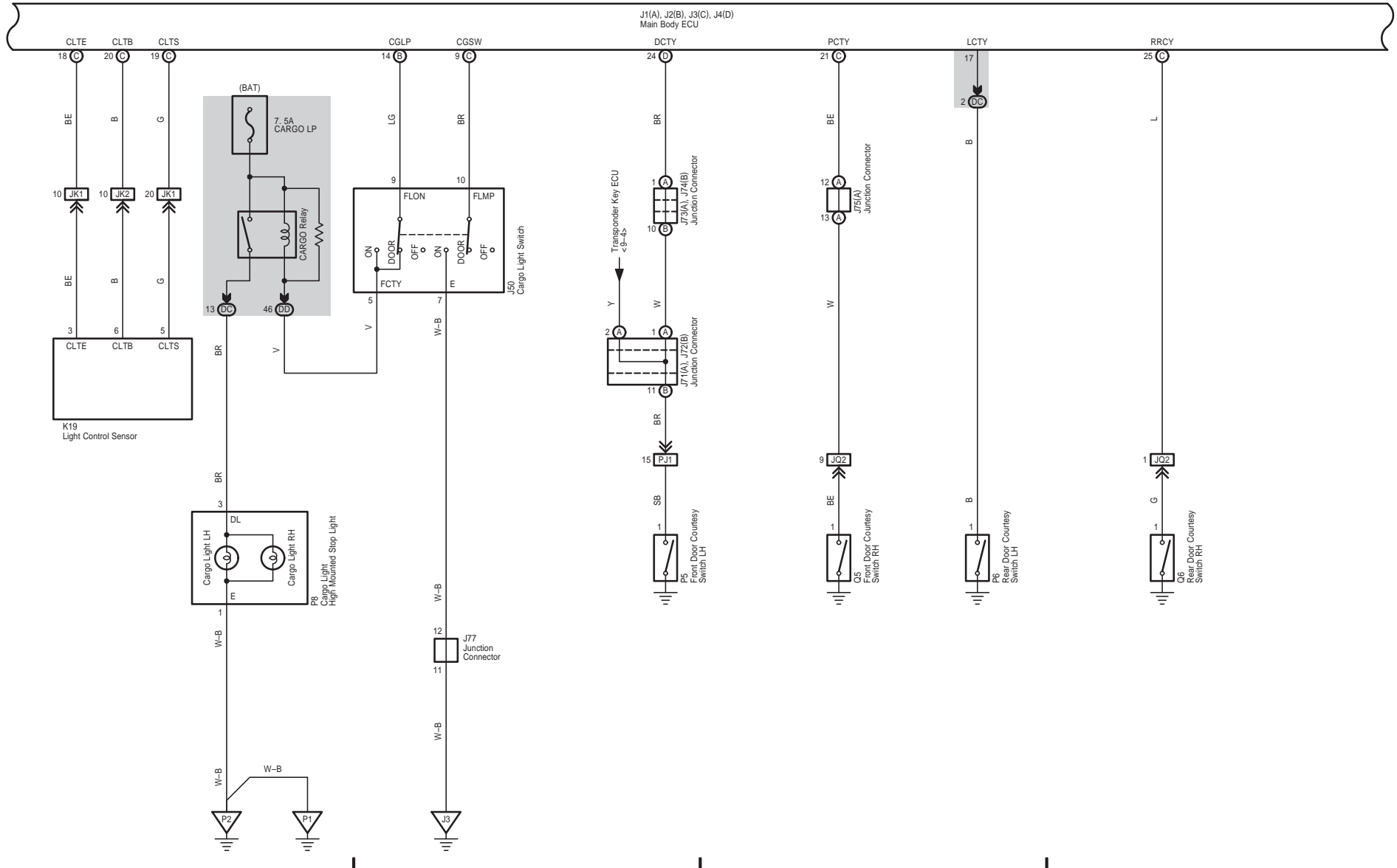

Multiplex Communication System (CAN)

29

30

31

32

J1(A), J2(B), J3(C), J4(D)  
Main Body ECU

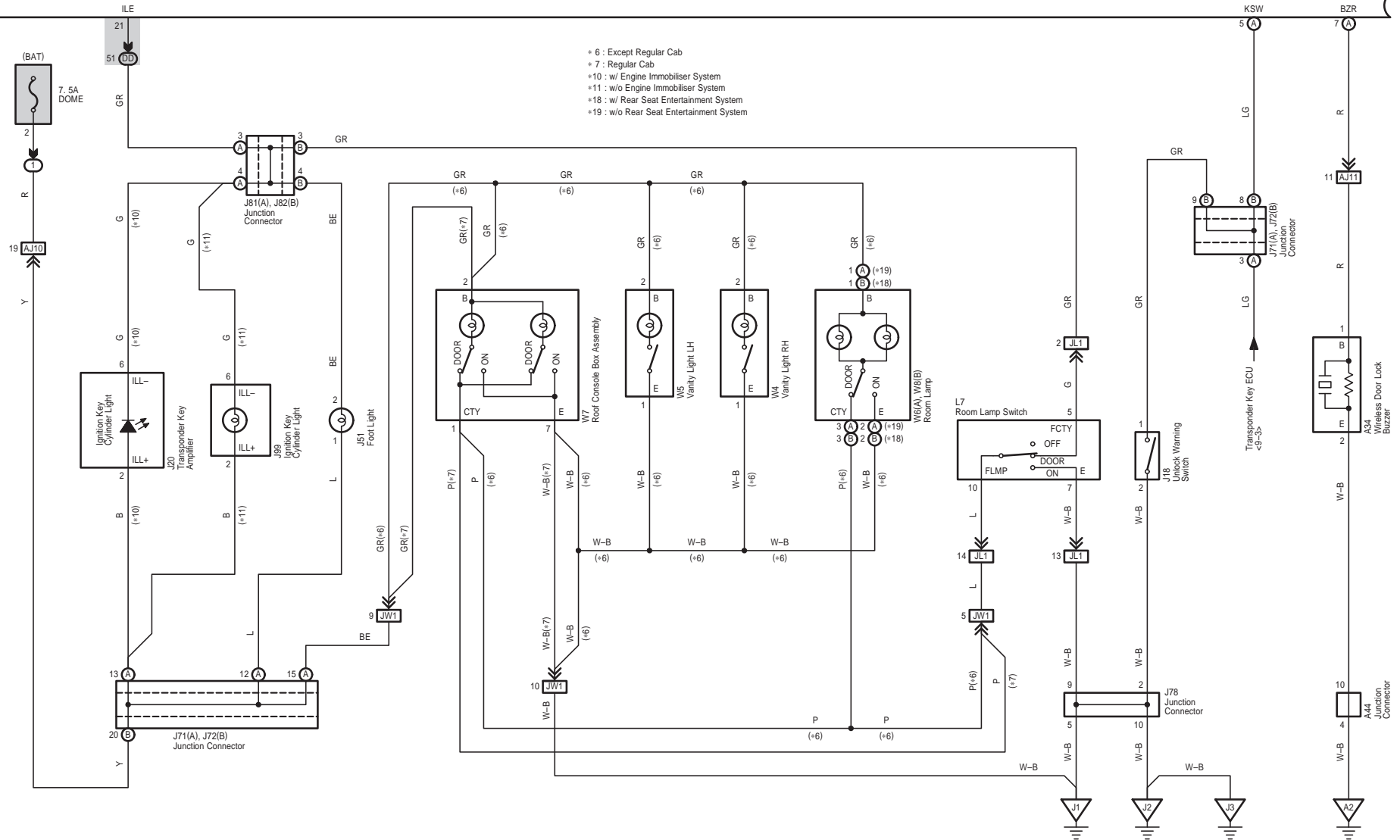

TOYOTA TUNDRA (EM16G1U)

Multiplex Communication System (CAN)

\*31 : w/ Power Seat  
 \*32 : w/o Power Seat

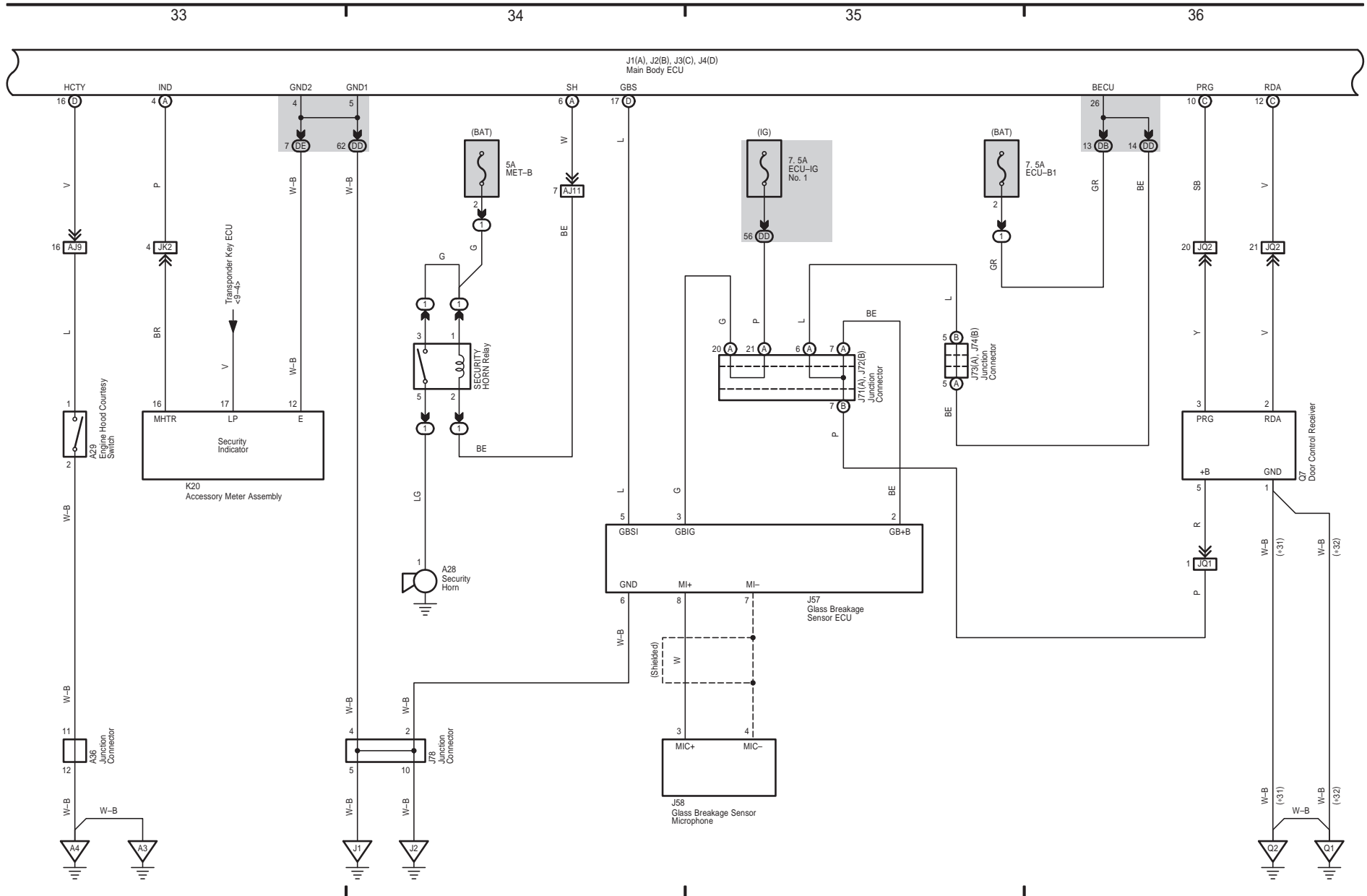

TOYOTA TUNDRA (EM16G1U)

M OVERALL ELECTRICAL WIRING DIAGRAM

Multiplex Communication System (CAN)

• 6 : Except Regular Cab  
 • 7 : Regular Cab

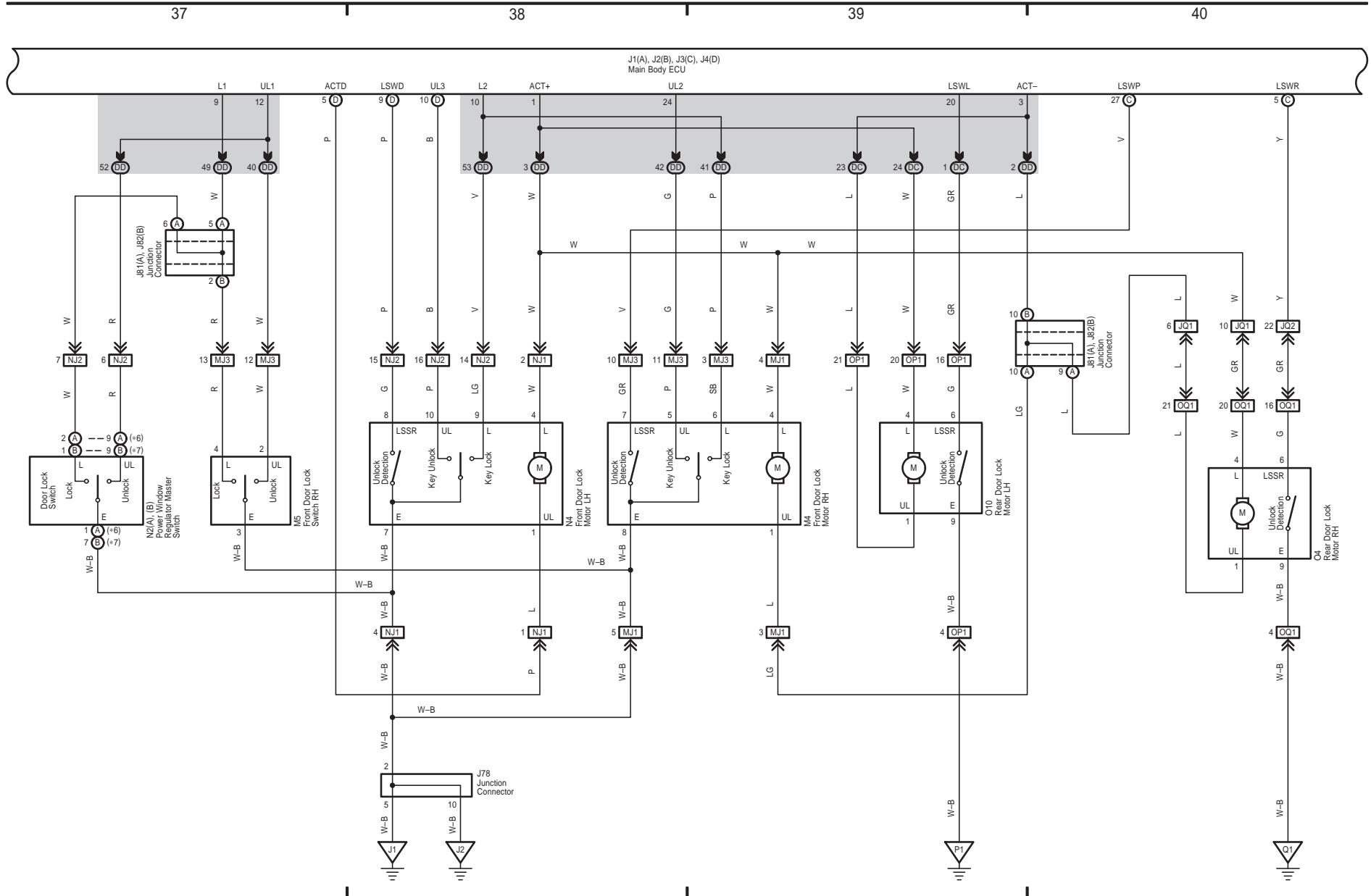

TOYOTA TUNDRA (EM16G1U)



Multiplex Communication System (CAN)

\*26 : w/ Auto Up

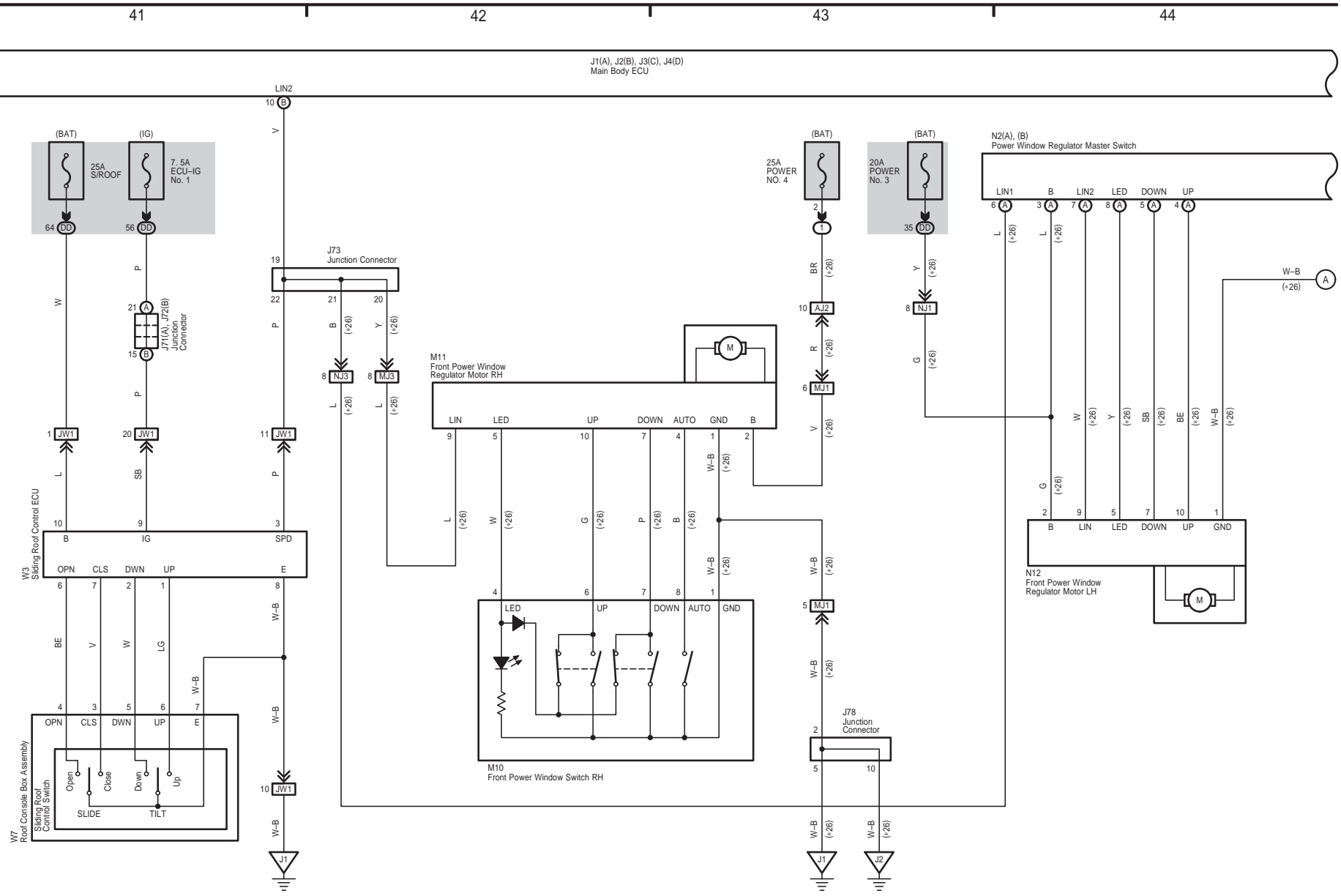

TOYOTA TUNDRA (EM16G1U)

M OVERALL ELECTRICAL WIRING DIAGRAM

Multiplex Communication System (CAN)

45

46

47

48

J1(A), J2(B), J3(C), J4(D)  
Main Body ECU

NZ2(A), (B)  
Power Window Regulator Master Switch

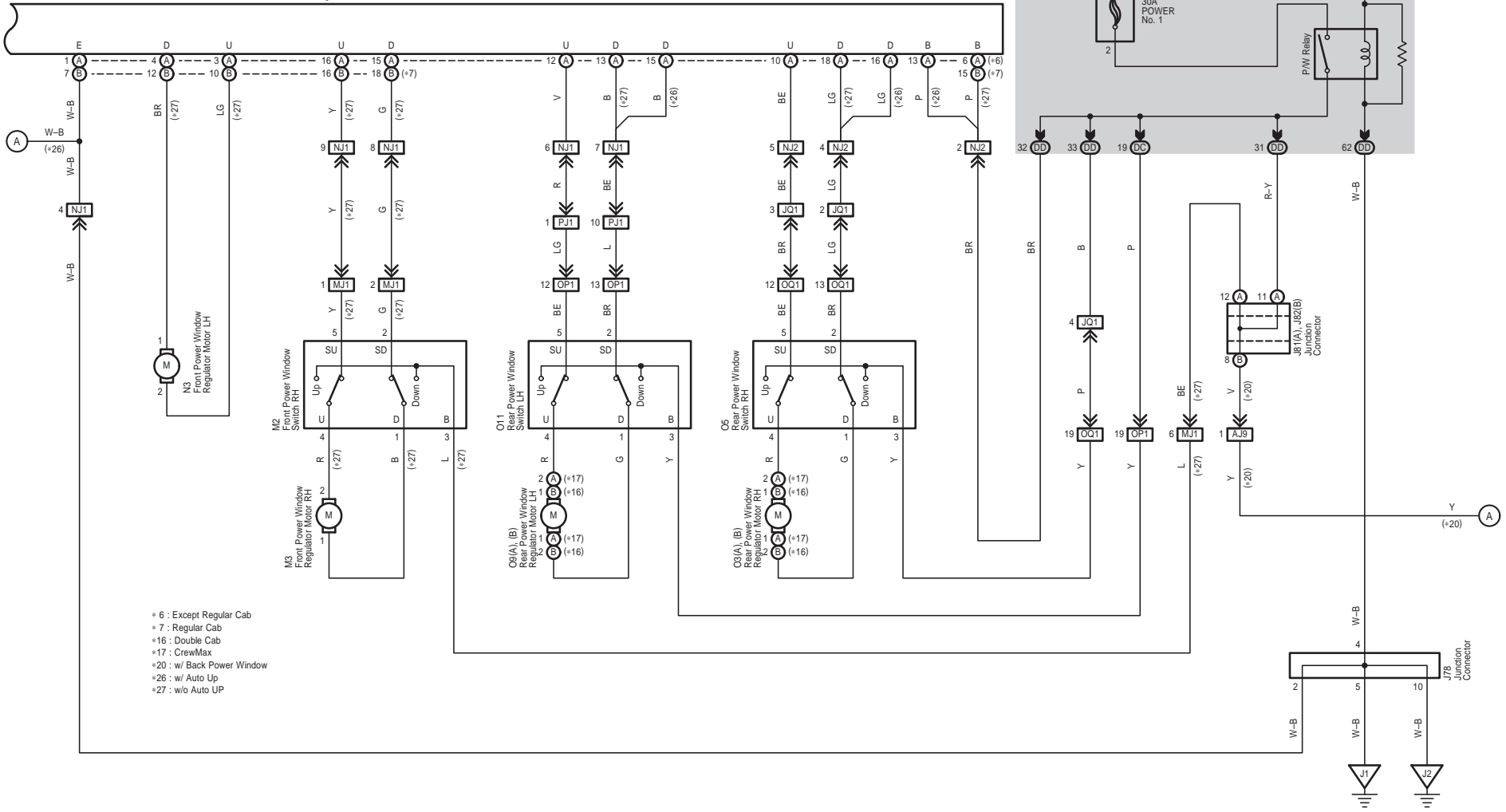

- \* 6 : Except Regular Cab
- \* 7 : Regular Cab
- \* 16 : Double Cab
- \* 17 : CrewMax
- \* 20 : w/ Back Power Window
- \* 26 : w/ Auto Up
- \* 27 : w/o Auto UP

Multiplex Communication System (CAN)

49

50

51

52

TOYOTA TUNDRA (EM16G1U)

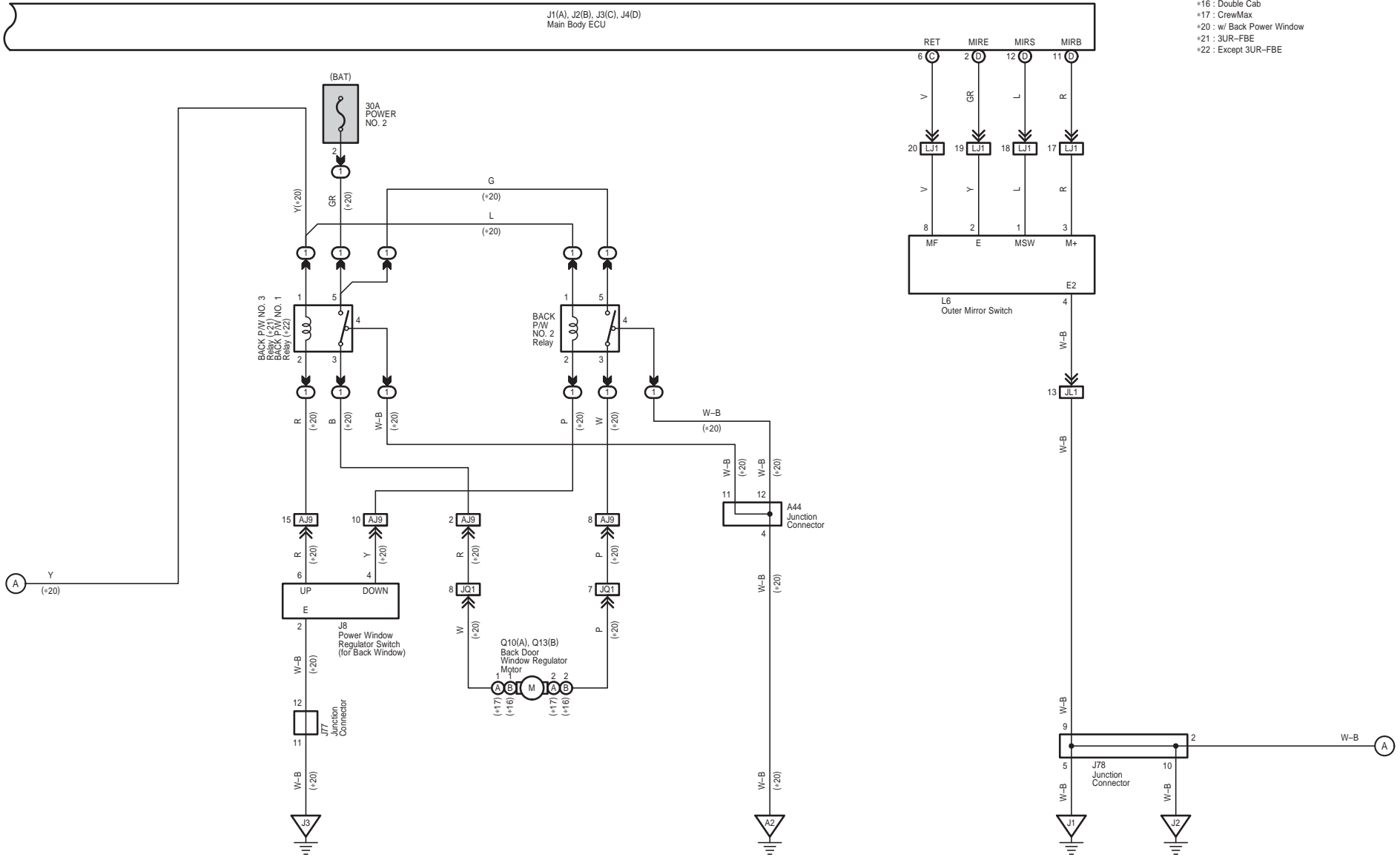

- \*16 : Double Cab
- \*17 : CrewMax
- \*20 : w/ Back Power Window
- \*21 : 3UR-FBE
- \*22 : Except 3UR-FBE

M OVERALL ELECTRICAL WIRING DIAGRAM



2 TOYOTA TUNDRA (Cont' d)

Multiplex Communication System (CAN)

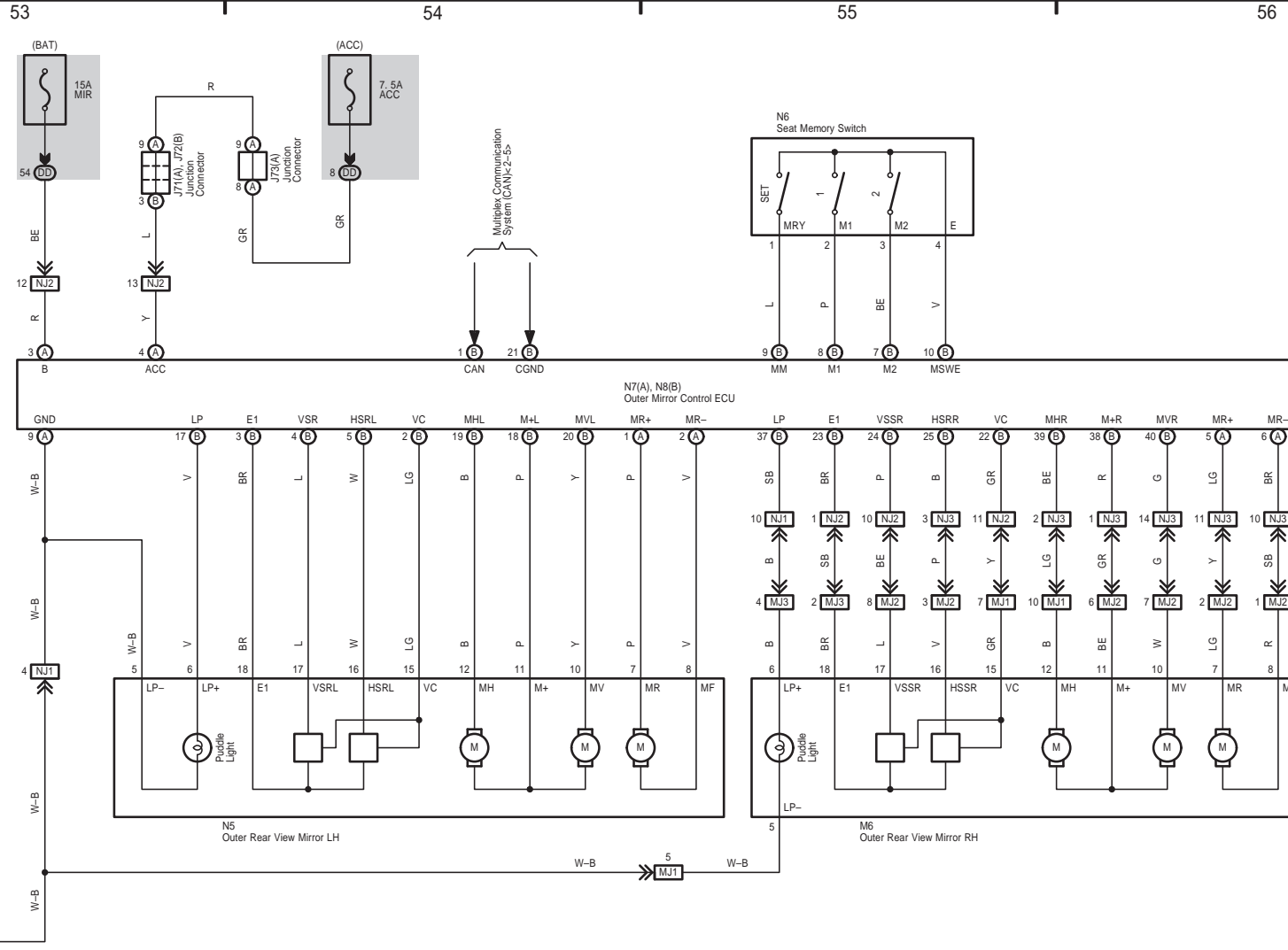

TOYOTA TUNDRA (EM16G1U)

3 TOYOTA TUNDRA

Starting

- \* 1 : 1GR-FE w/ Cold Area Spec.
- \* 2 : 1GR-FE w/o Cold Area Spec.
- \* 3 : 3UR-FE, 3UR-FBE, 1UR-FE
- \* 4 : 1GR-FE From Oct. 2010 Production
- \* 5 : 1GR-FE Before Oct. 2010 Production

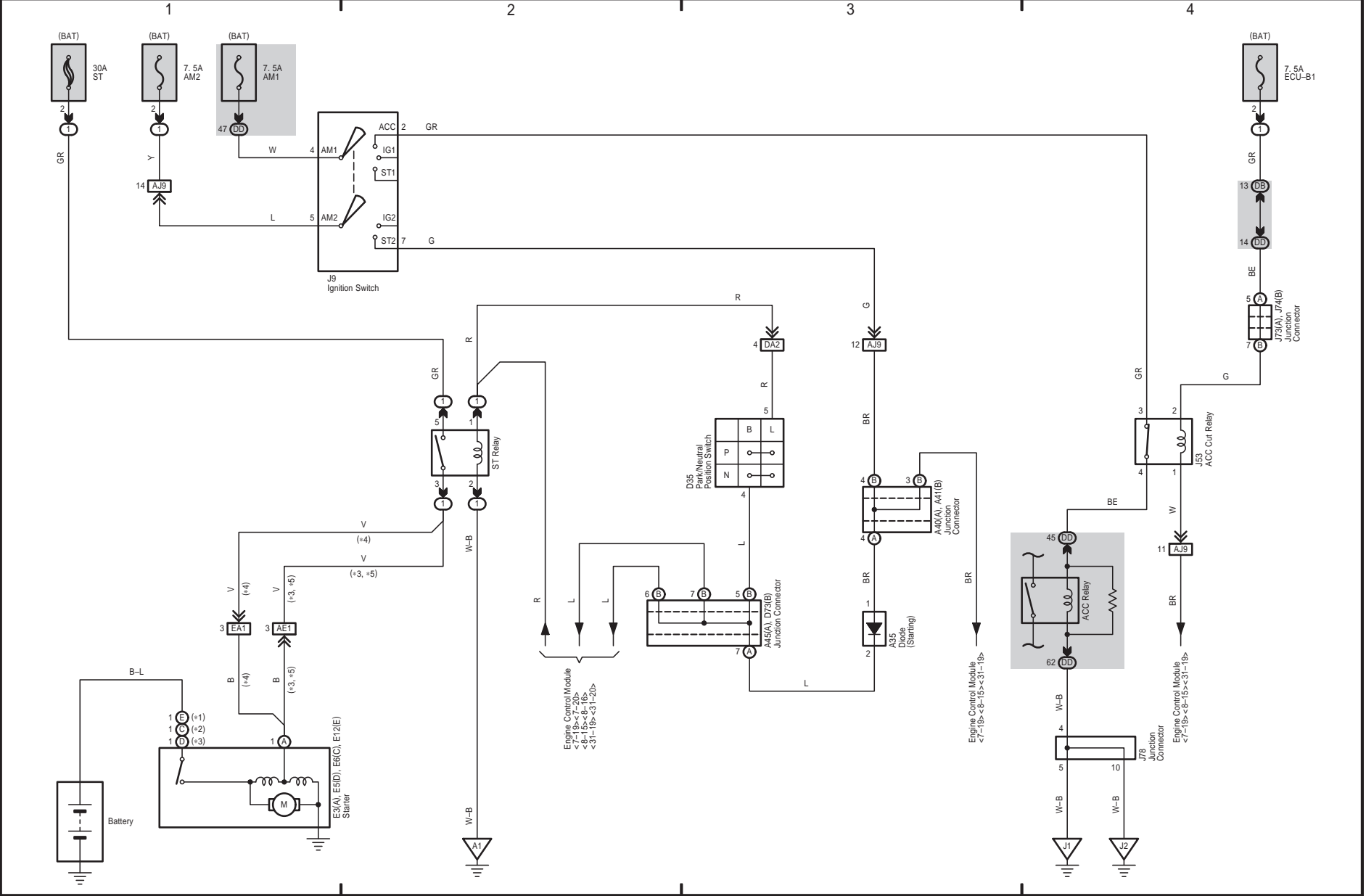

4 TOYOTA TUNDRA

Charging

- \* 3 : 3UR-FE, 3UR-FBE, 1UR-FE
- \* 4 : 1GR-FE
- \* 5 : 1GR-FE Before Oct. 2010 Production
- \* 6 : 1GR-FE From Oct. 2010 Production

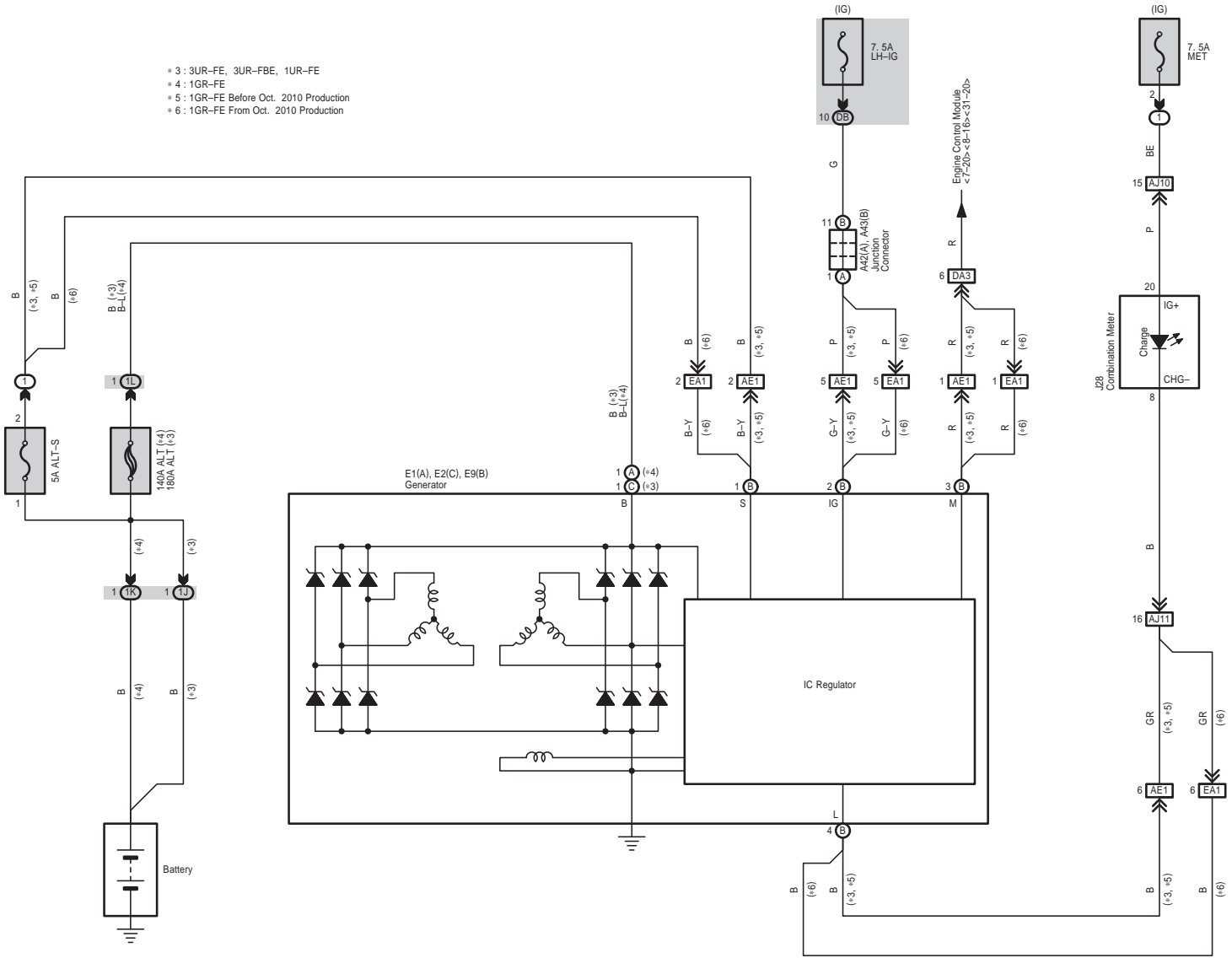

5 TOYOTA TUNDRA

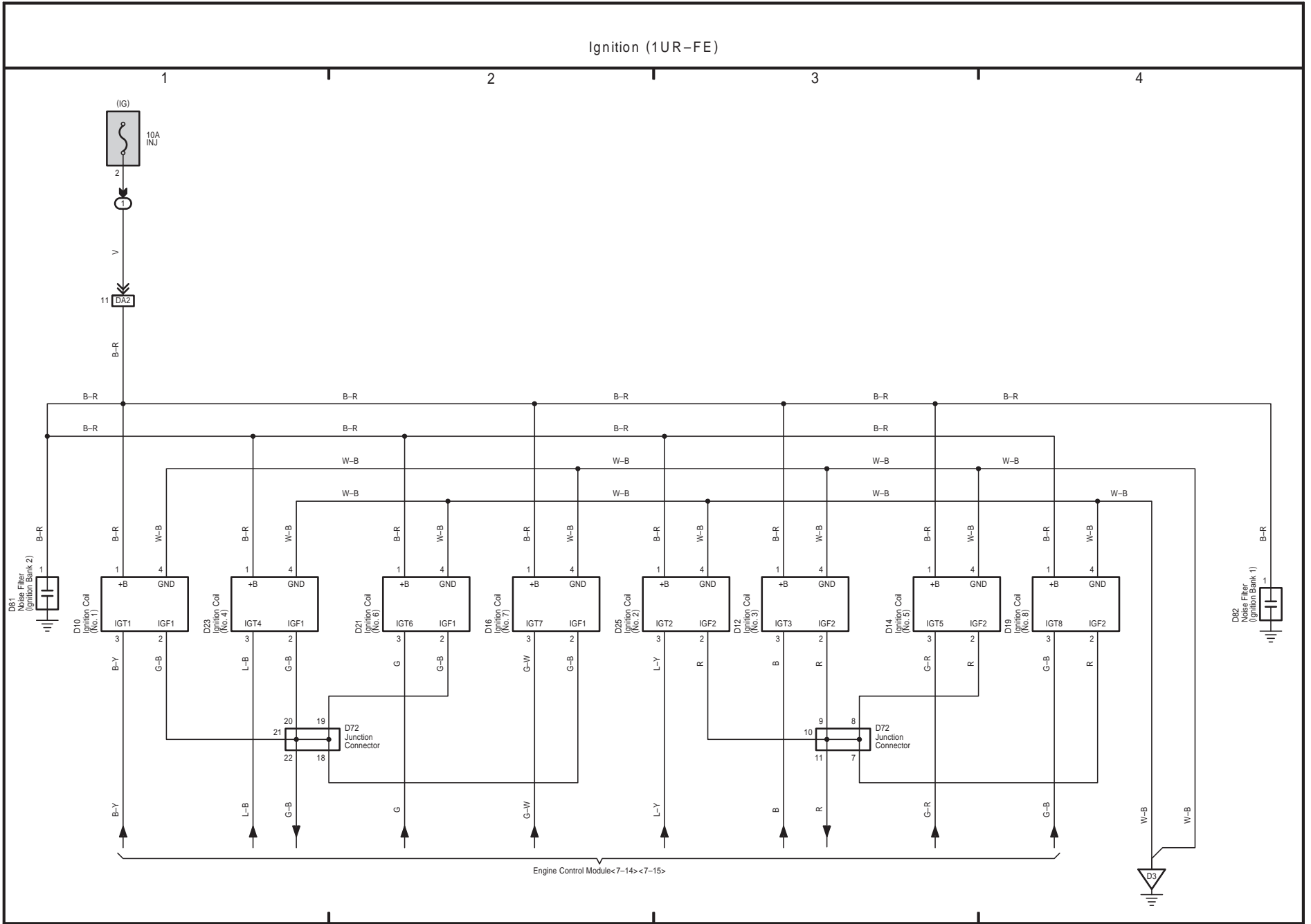

TOYOTA TUNDRA (EM16G1U)

6 TOYOTA TUNDRA

Ignition (1GR-FE)

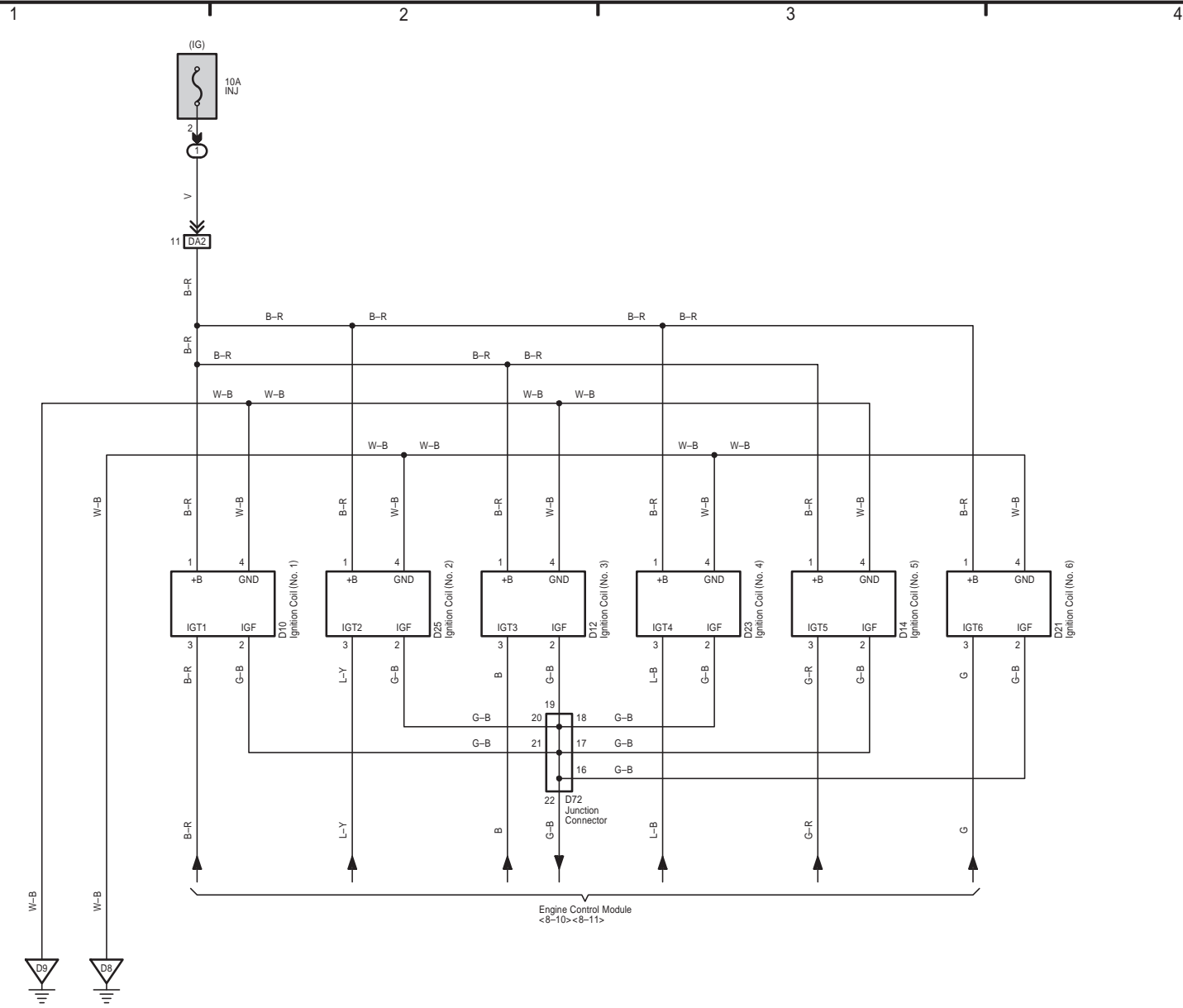

TOYOTA TUNDRA (EM16G1U)

Engine Control (1UR-FE)

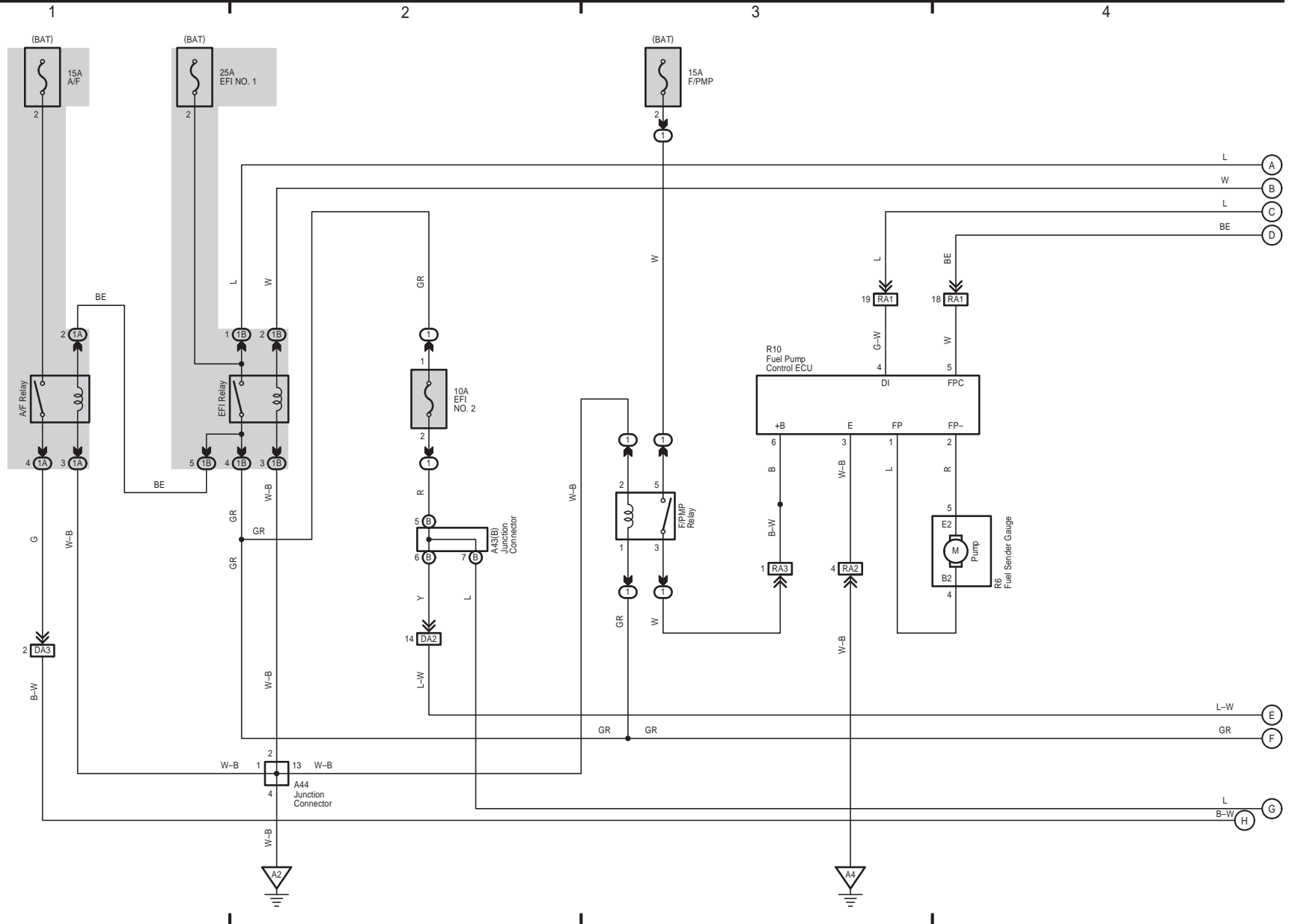

TOYOTA TUNDRA (EM16G1U)

Engine Control (1UR-FE)

TOYOTA TUNDRA (EM16G1U)

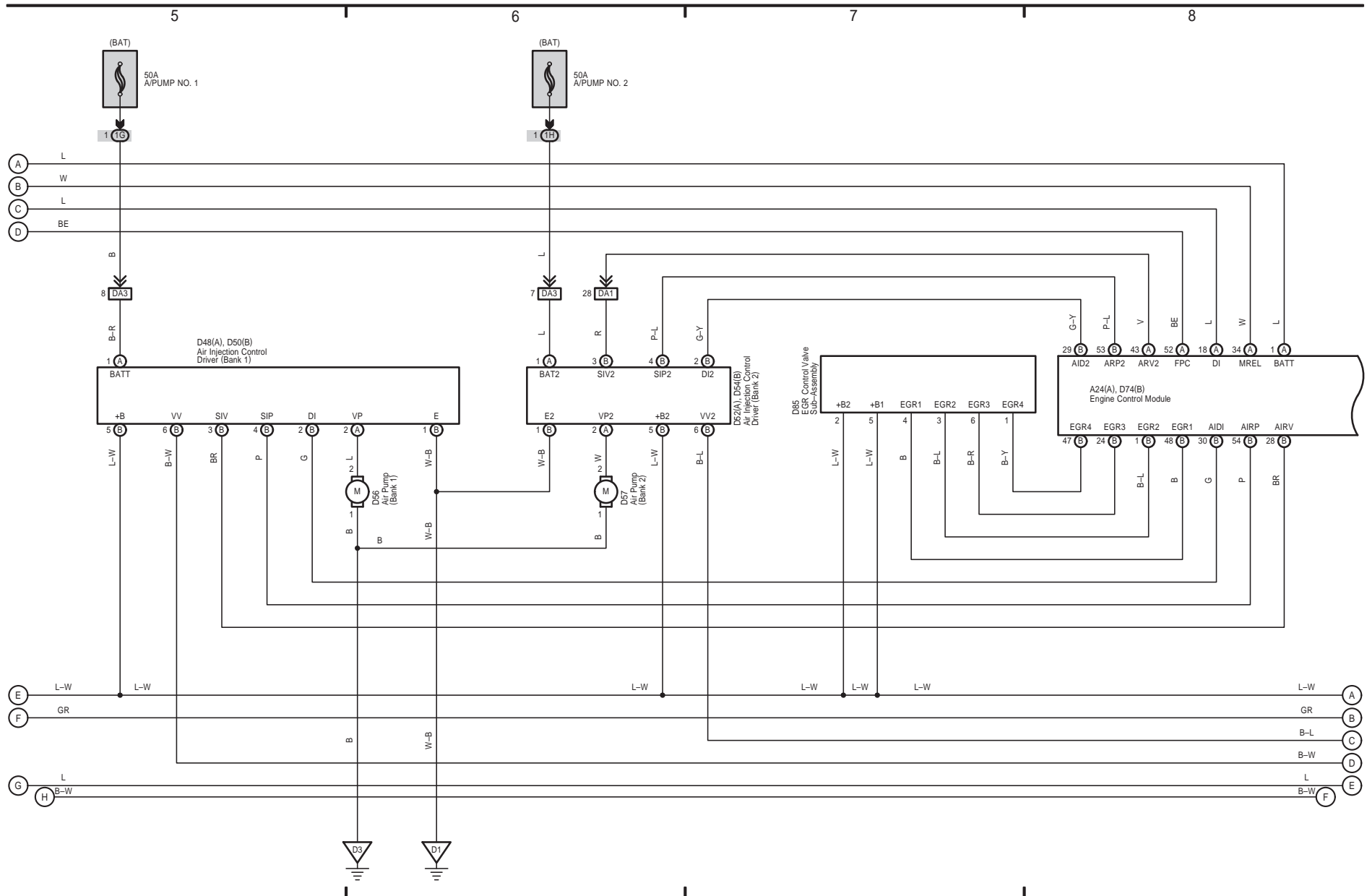

Engine Control (1UR-FE)

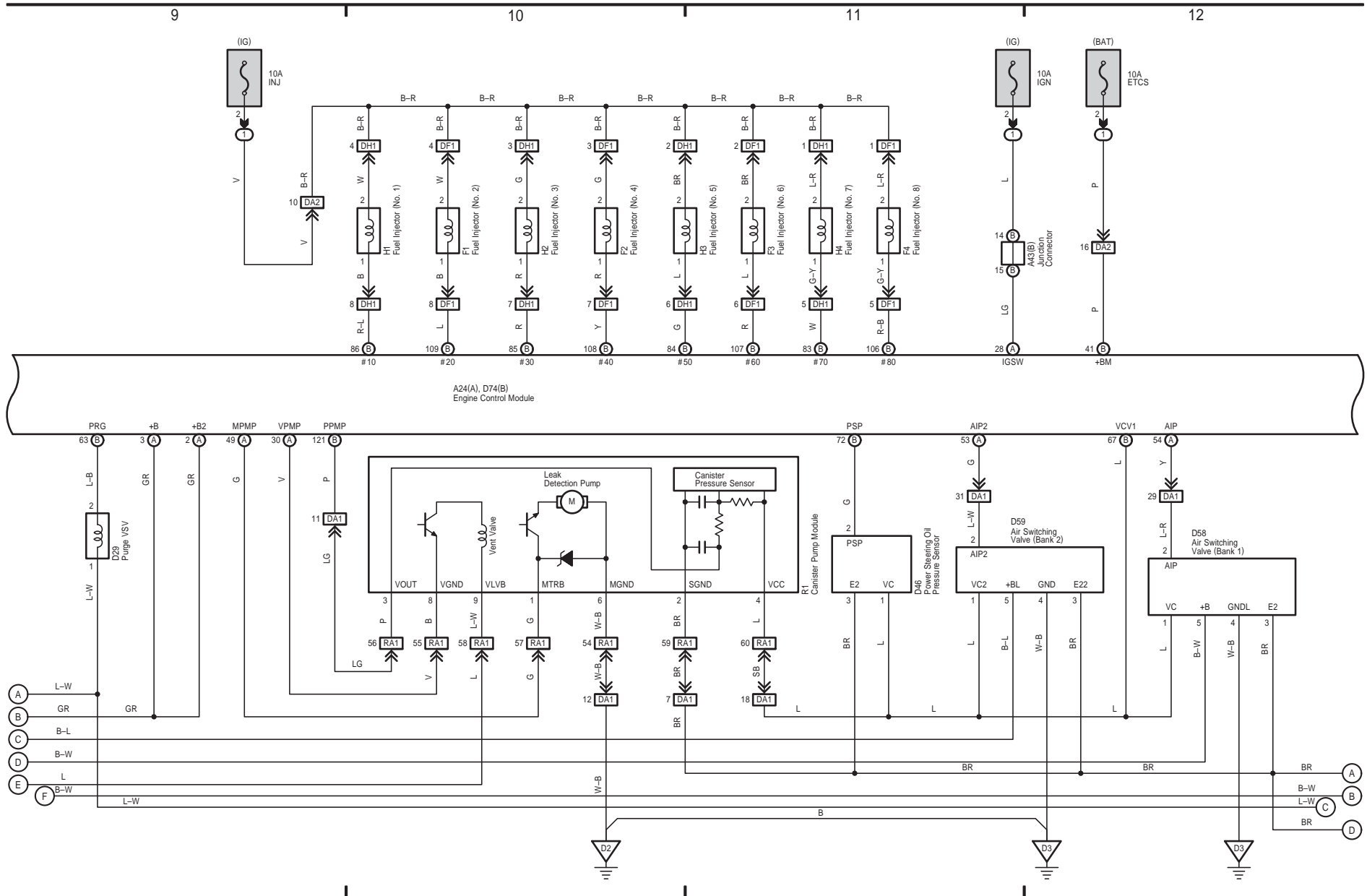



Engine Control (1UR-FE)

\* 1 : Shielded

13

14

15

16

TOYOTA TUNDRA (EM16G1U)

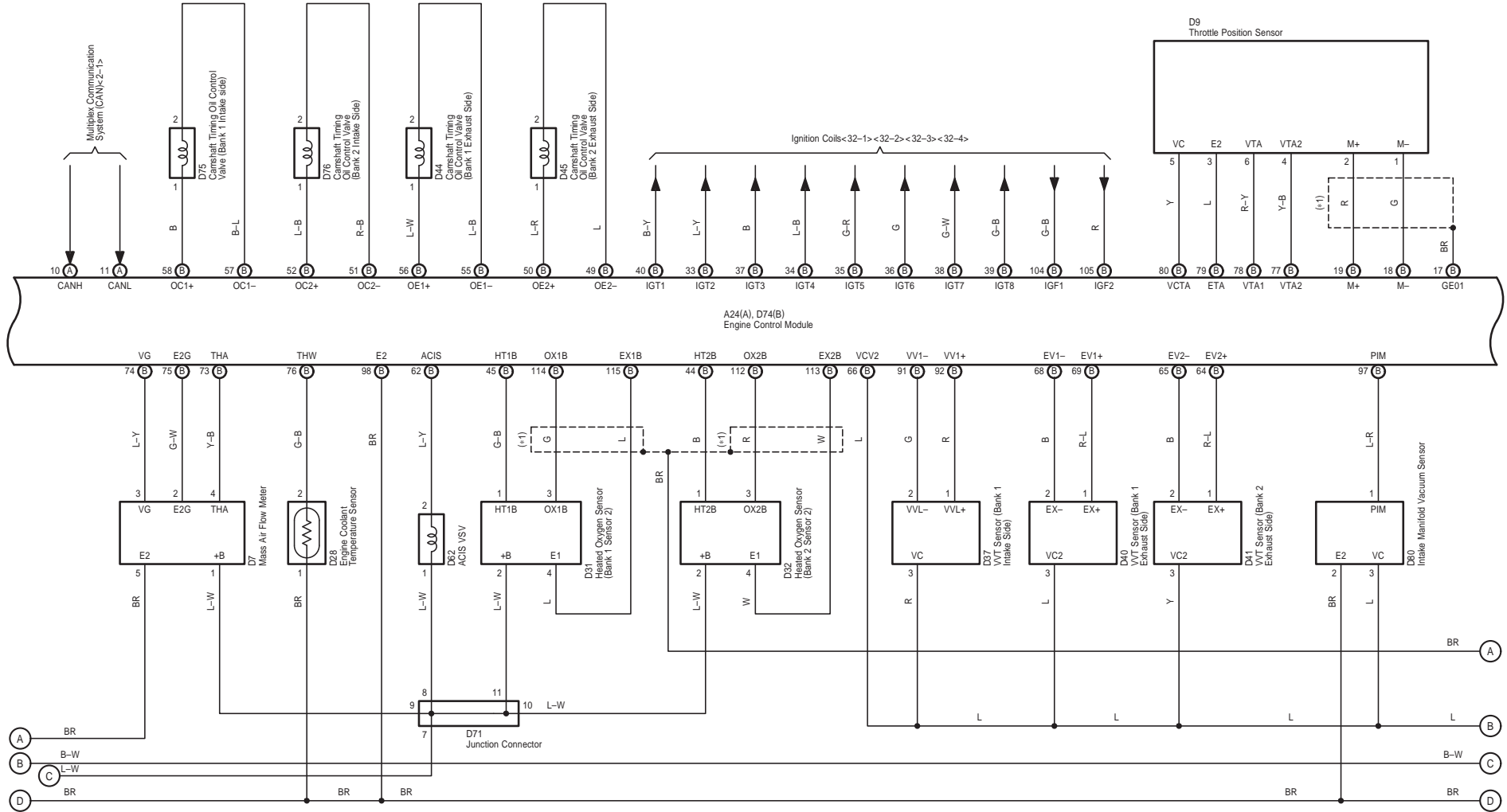

Engine Control (1UR-FE)

\* 1 : Shielded

17

18

19

20

A14 Accelerator Position Sensor

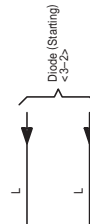
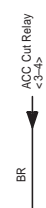
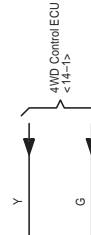
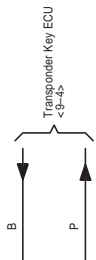
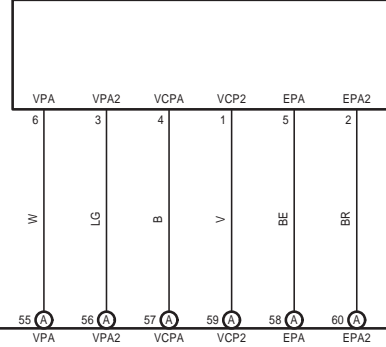

A24(A), D74(B) Engine Control Module

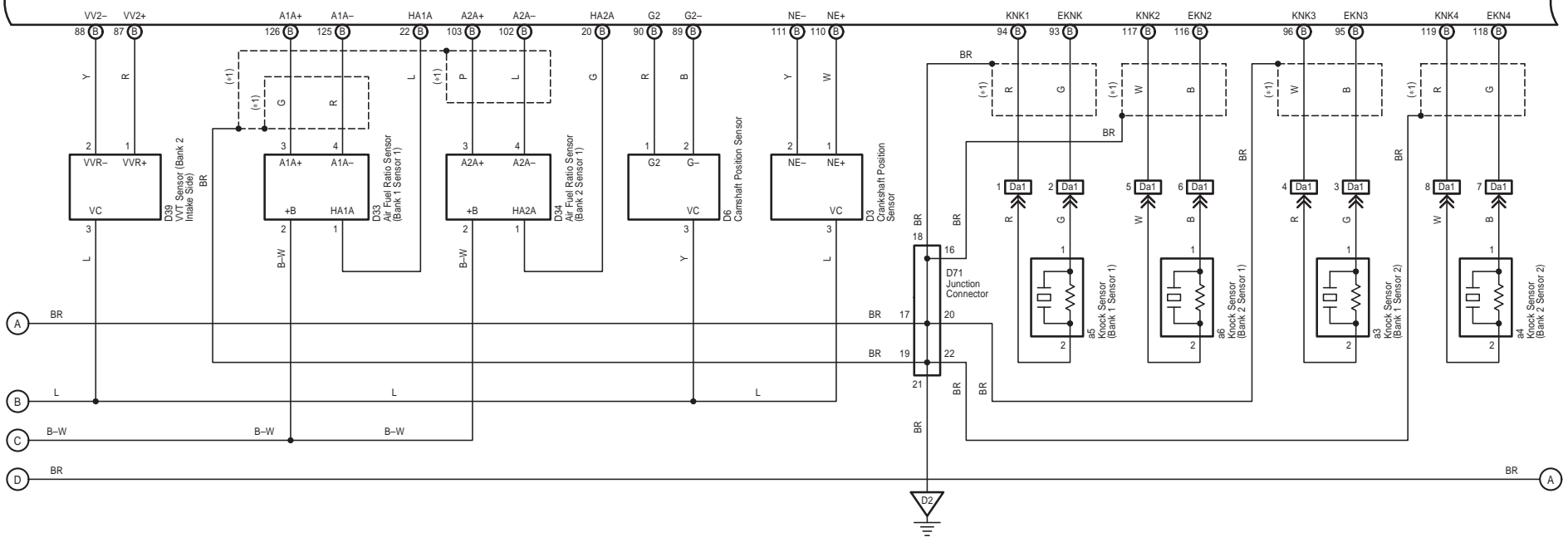

TOYOTA TUNDRA (EM16G1U)

M OVERALL ELECTRICAL WIRING DIAGRAM

Cruise Control (1UR-FE)

21

22

23

24

TOYOTA TUNDRA (EM16G1U)

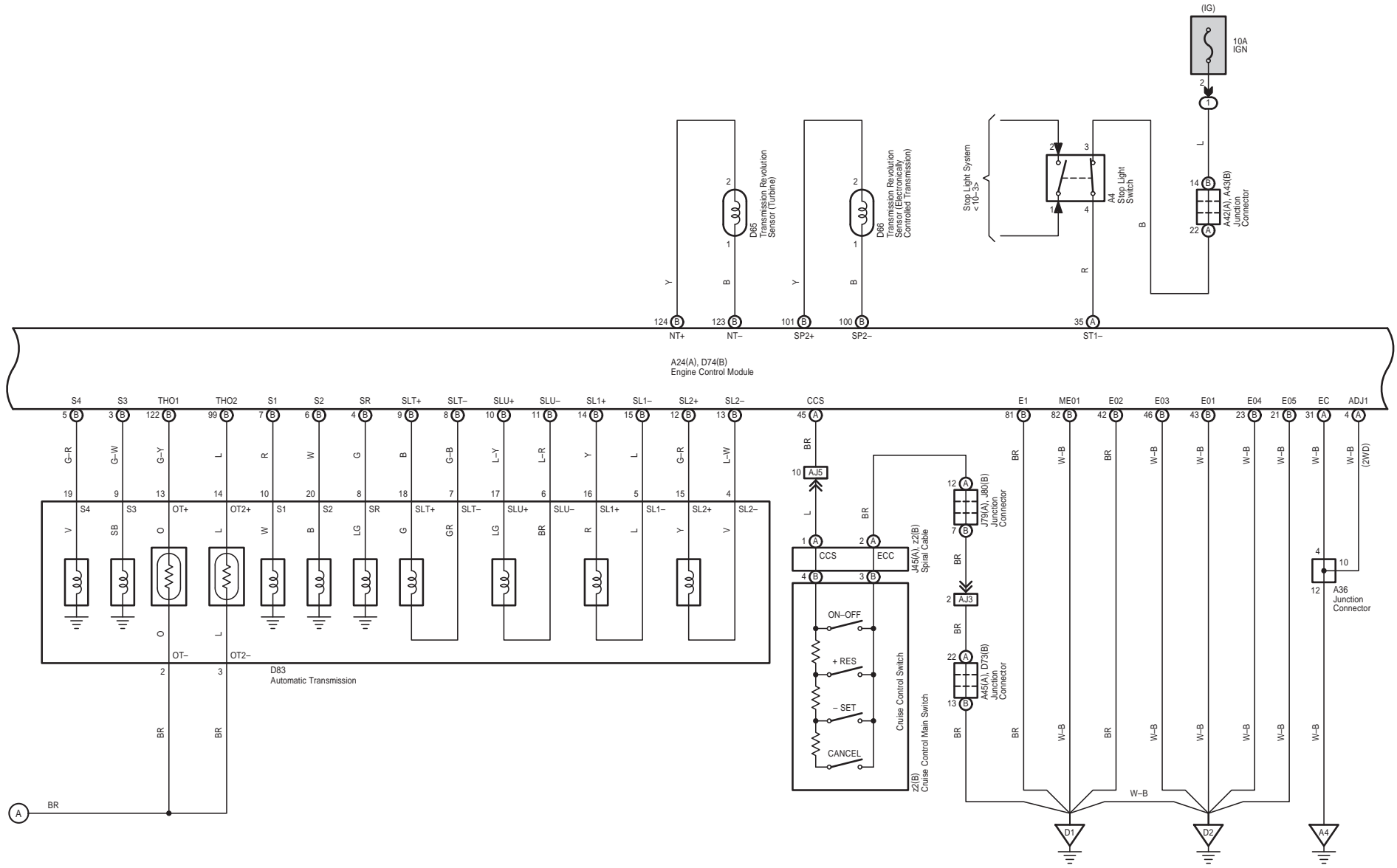

Electronically Controlled Transmission and A/T Indicator (1UR-FE)

\* 2 : Floor Shift  
\* 3 : Column Shift

25

26

27

28

TOYOTA TUNDRA (EM16G1U)

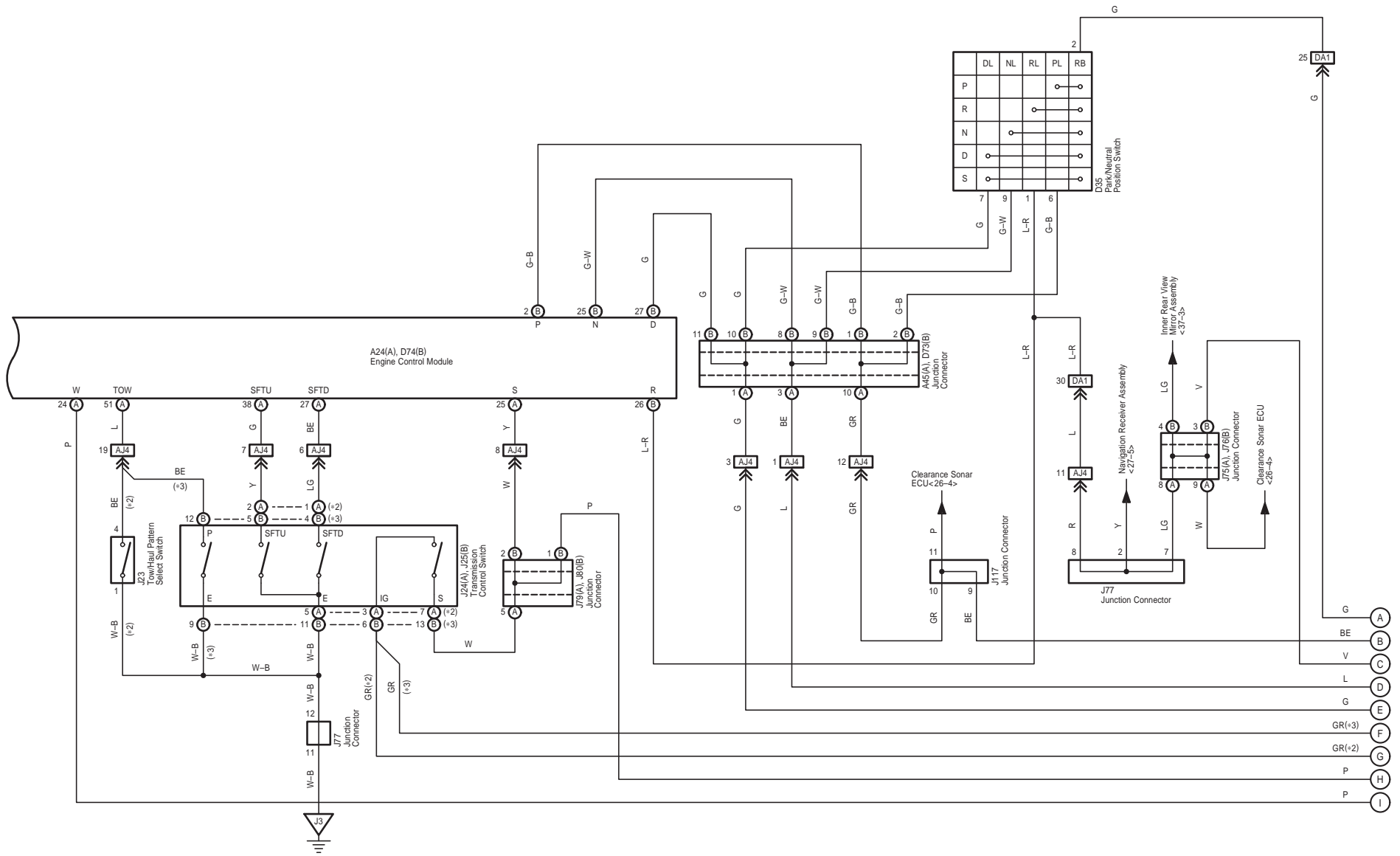

Electronically Controlled Transmission and A/T Indicator (1UR-FE)

TOYOTA TUNDRA (EM16G1U)

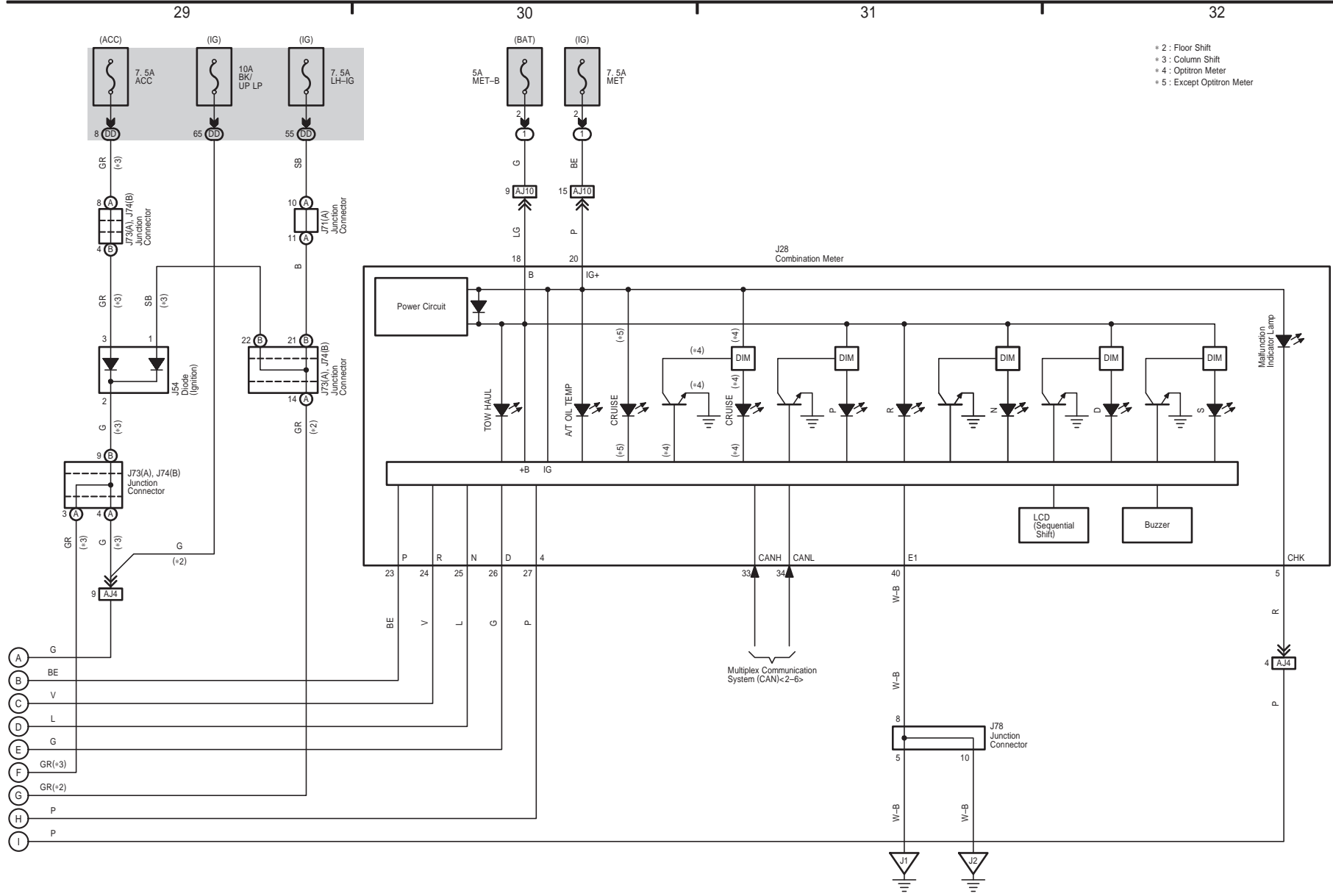

TOYOTA TUNDRA (EM16G1U)

M OVERALL ELECTRICAL WIRING DIAGRAM

Engine Control (1GR-FE)

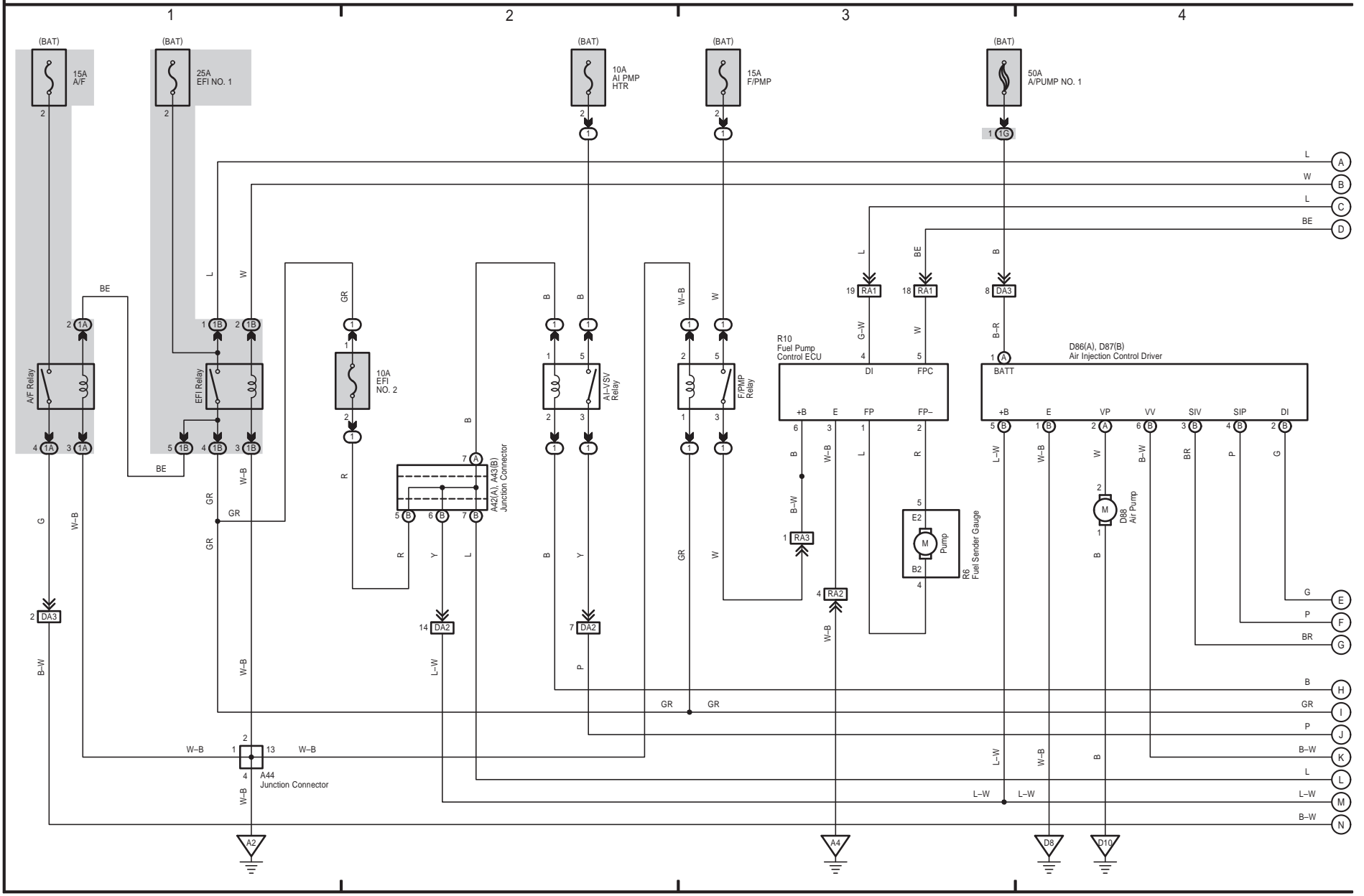

Engine Control (1GR-FE)

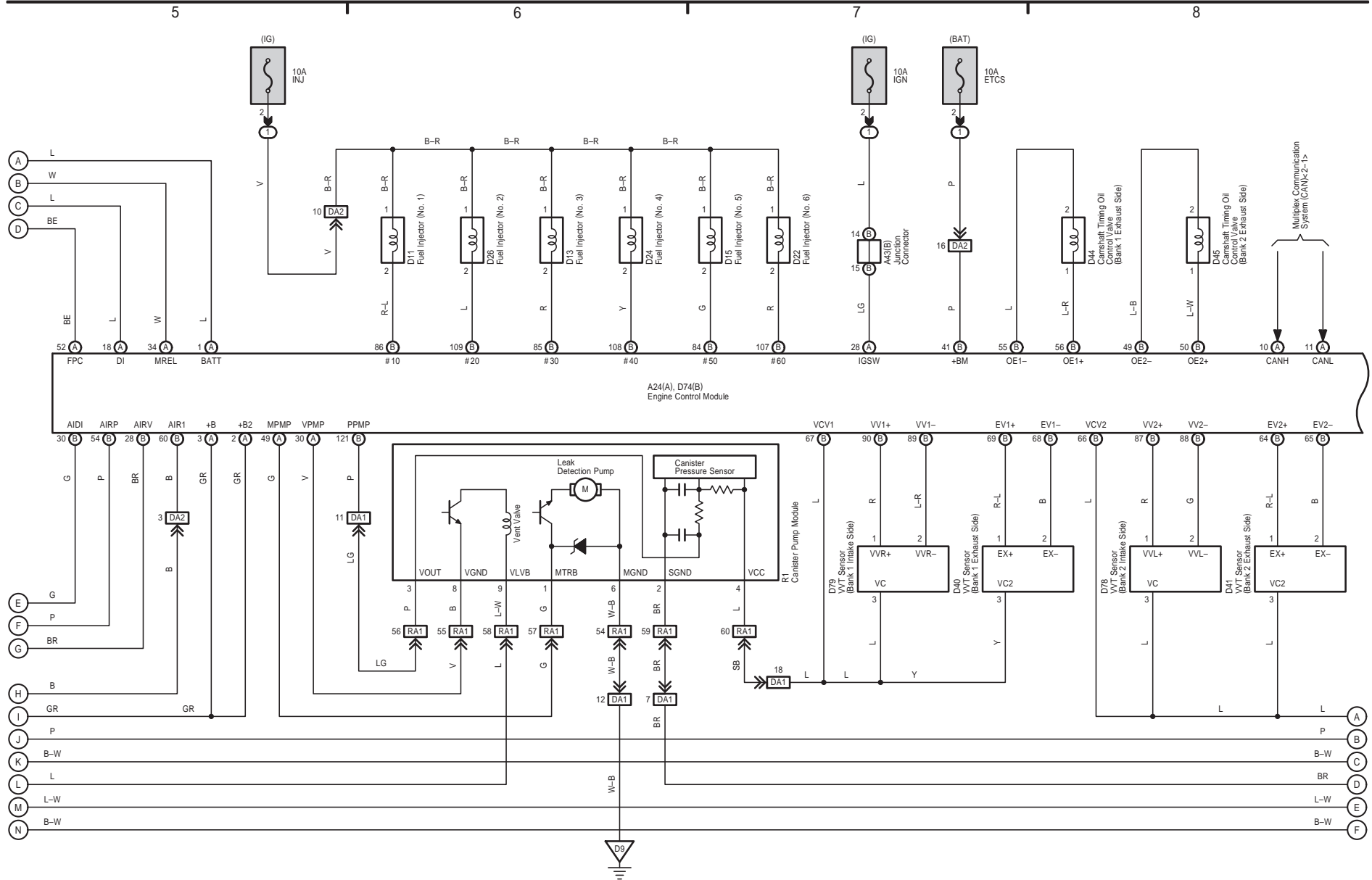

TOYOTA TUNDRA (EM16G1U)



Engine Control (1GR-FE)

\* 1 : Shielded

9

10

11

12

TOYOTA TUNDRA (EM16G1U)

M OVERALL ELECTRICAL WIRING DIAGRAM

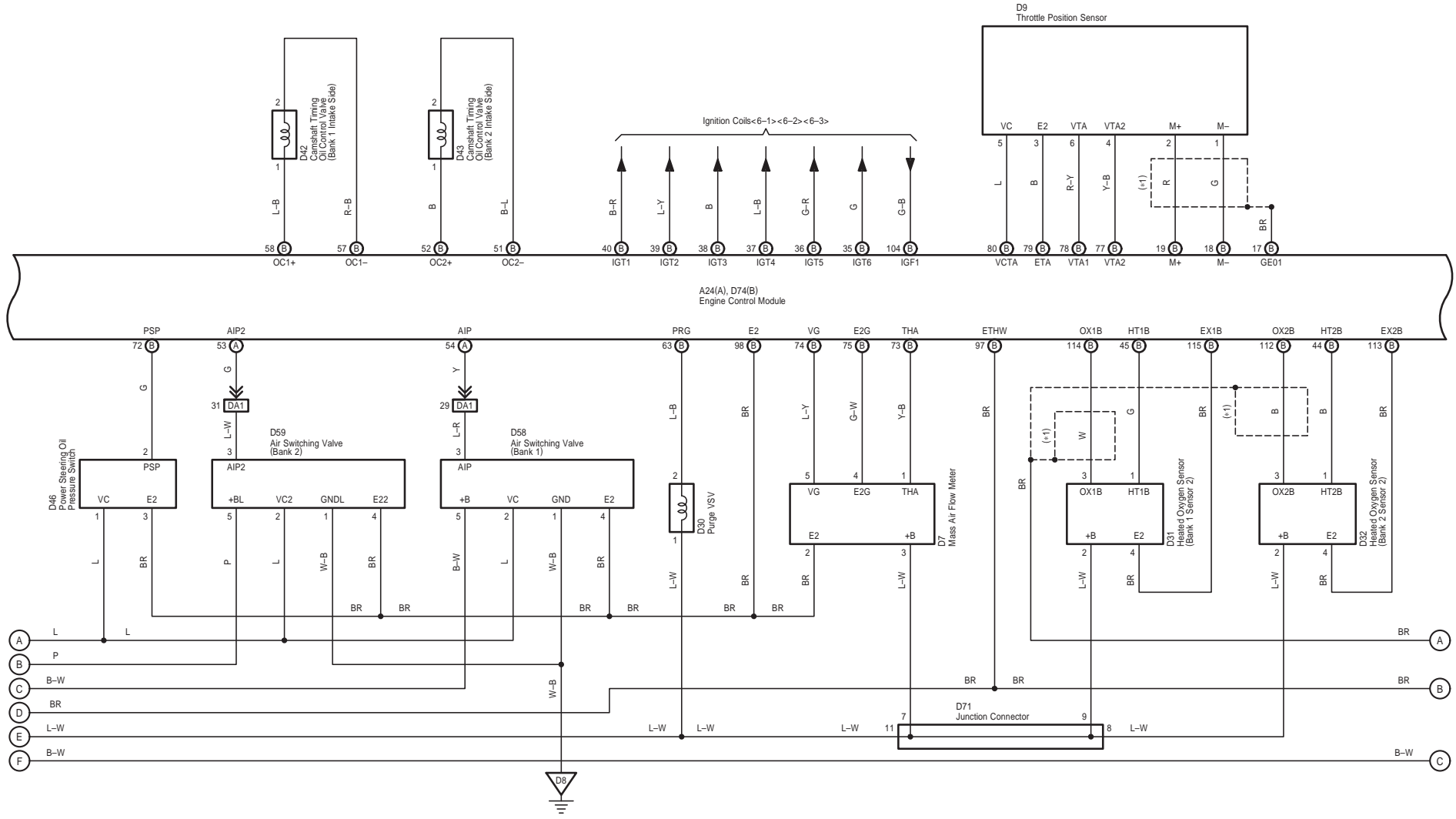



Engine Control (1GR-FE)

\* 1 : Shielded

13

14

15

16

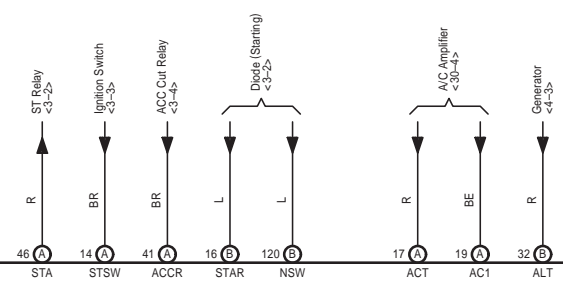
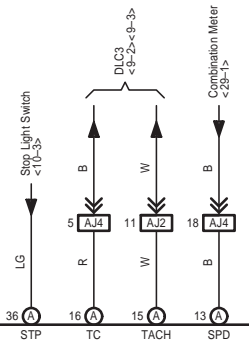
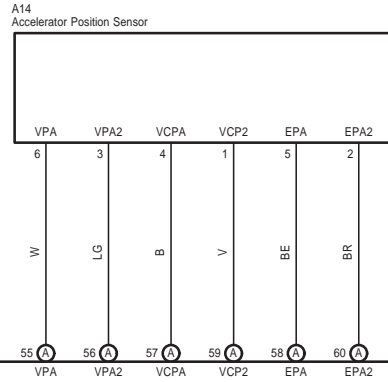

A24(A), D74(B)  
Engine Control Module

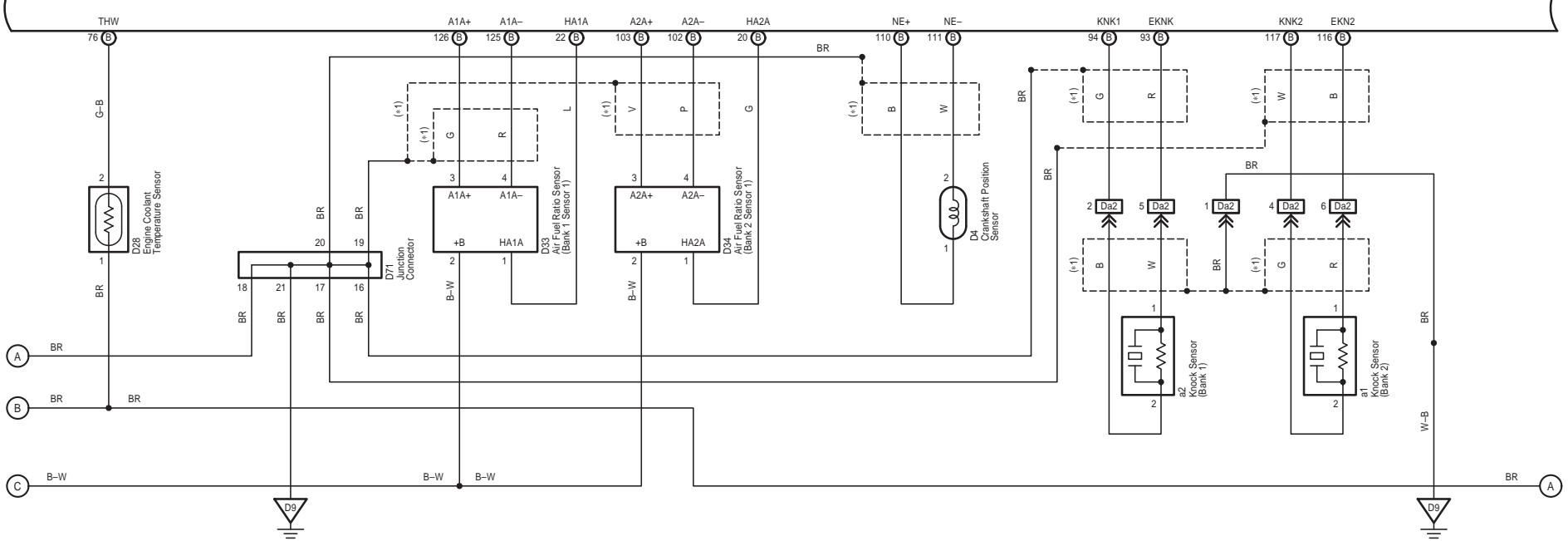

TOYOTA TUNDRA (EM16G1U)



Cruise Control (1GR-FE)

17

18

19

20

TOYOTA TUNDRA (EM16G1U)

M OVERALL ELECTRICAL WIRING DIAGRAM

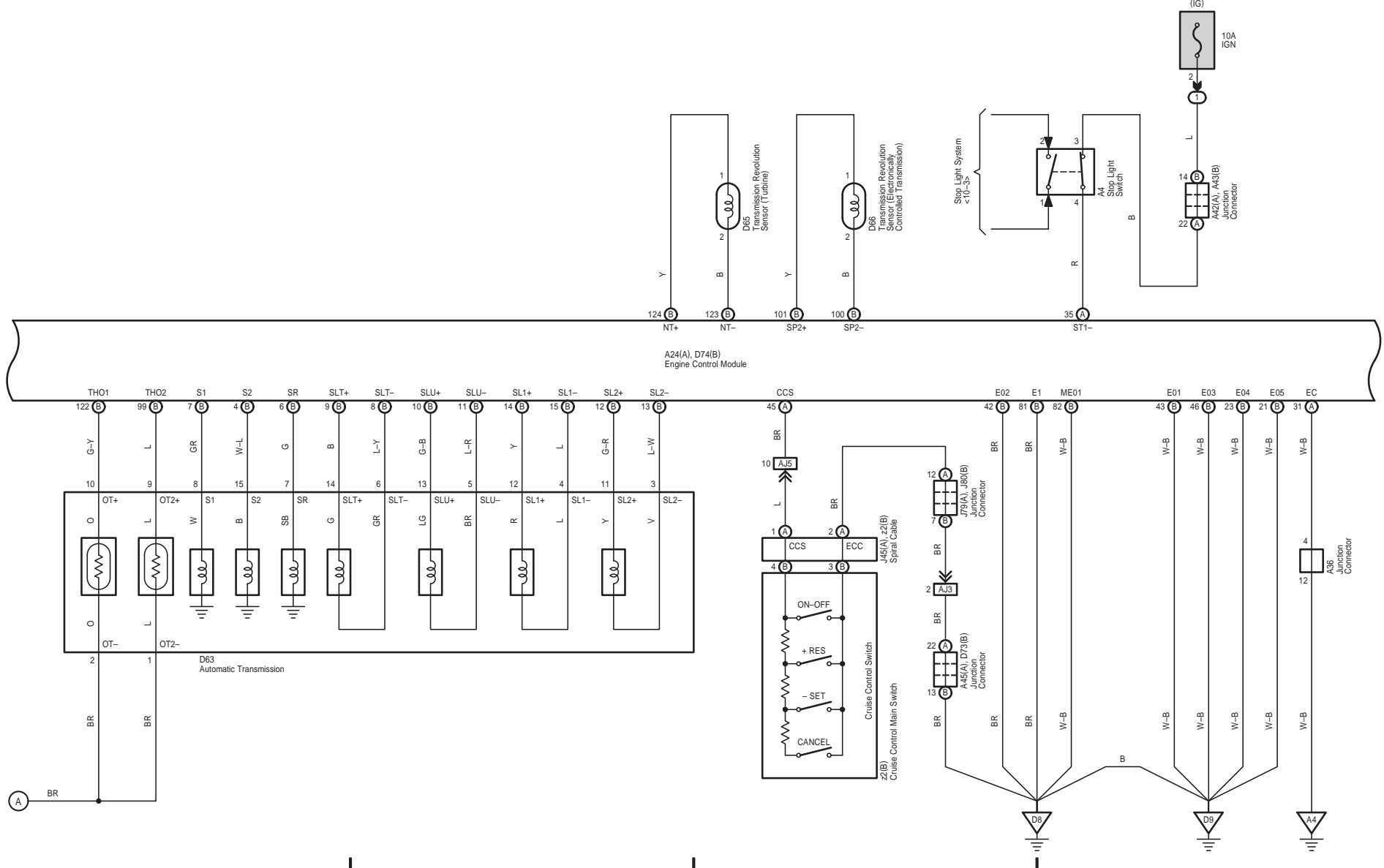

Electronically Controlled Transmission and A/T Indicator (1GR-FE)

+ 2 : Floor Shift  
+ 3 : Column Shift

21

22

23

24

TOYOTA TUNDRA (EM16G1U)

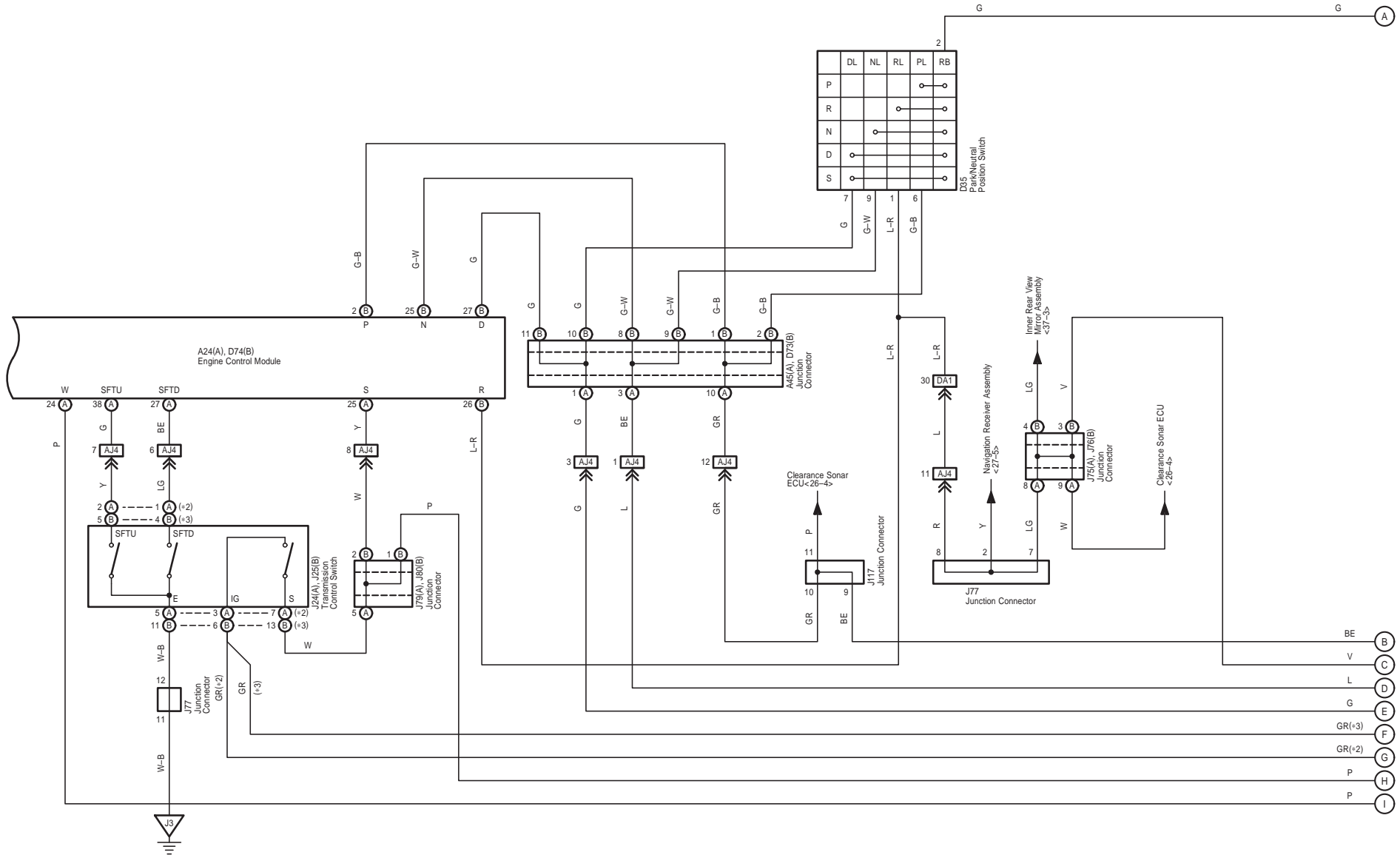

Electronically Controlled Transmission and A/T Indicator (1GR-FE)

\* 2 : Floor Shift  
 \* 3 : Column Shift

TOYOTA TUNDRA (EM16G1U)

M OVERALL ELECTRICAL WIRING DIAGRAM

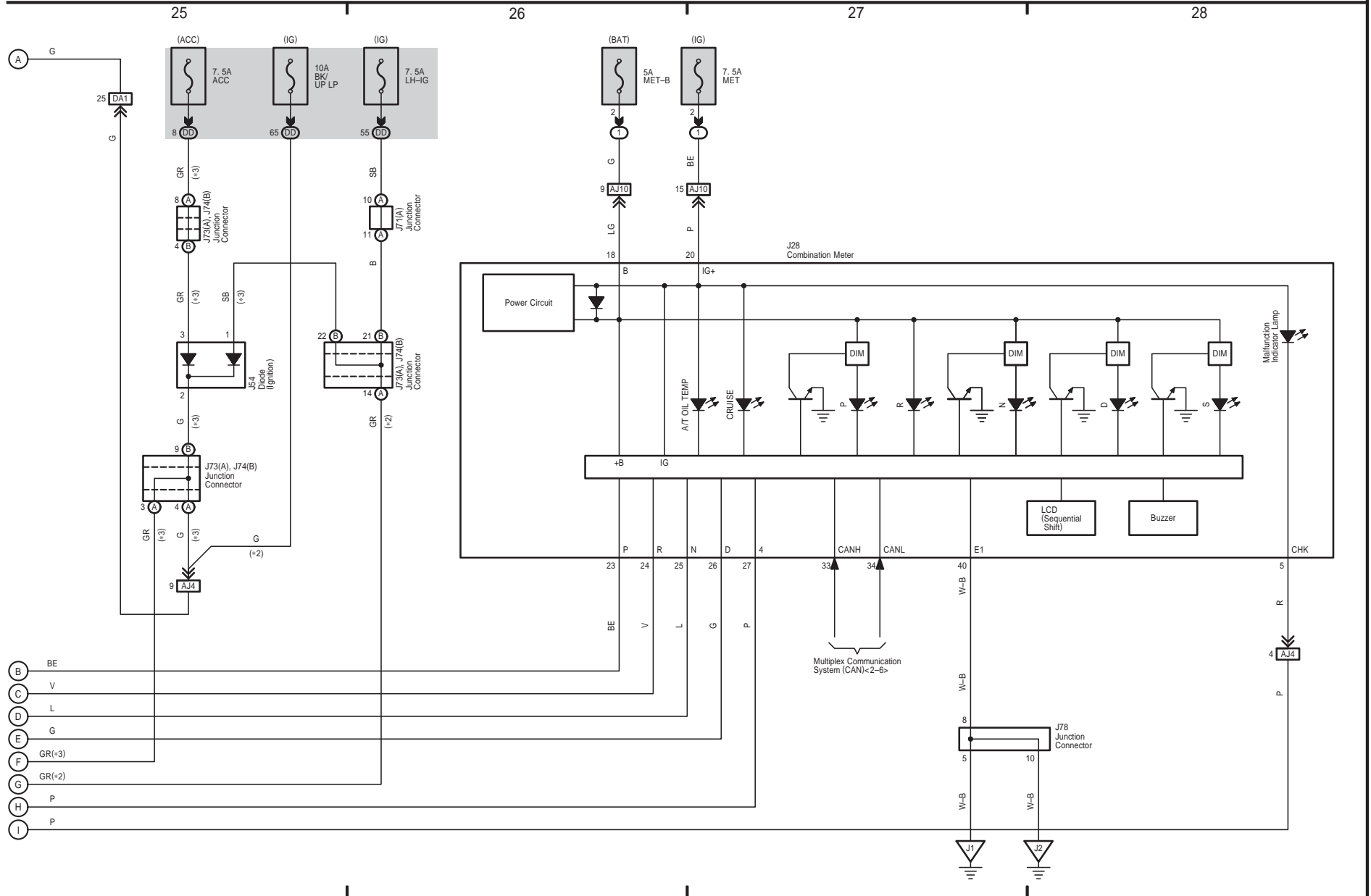

# 9 TOYOTA TUNDRA

TOYOTA TUNDRA (EM16G1U)

## Data Link Connector 3

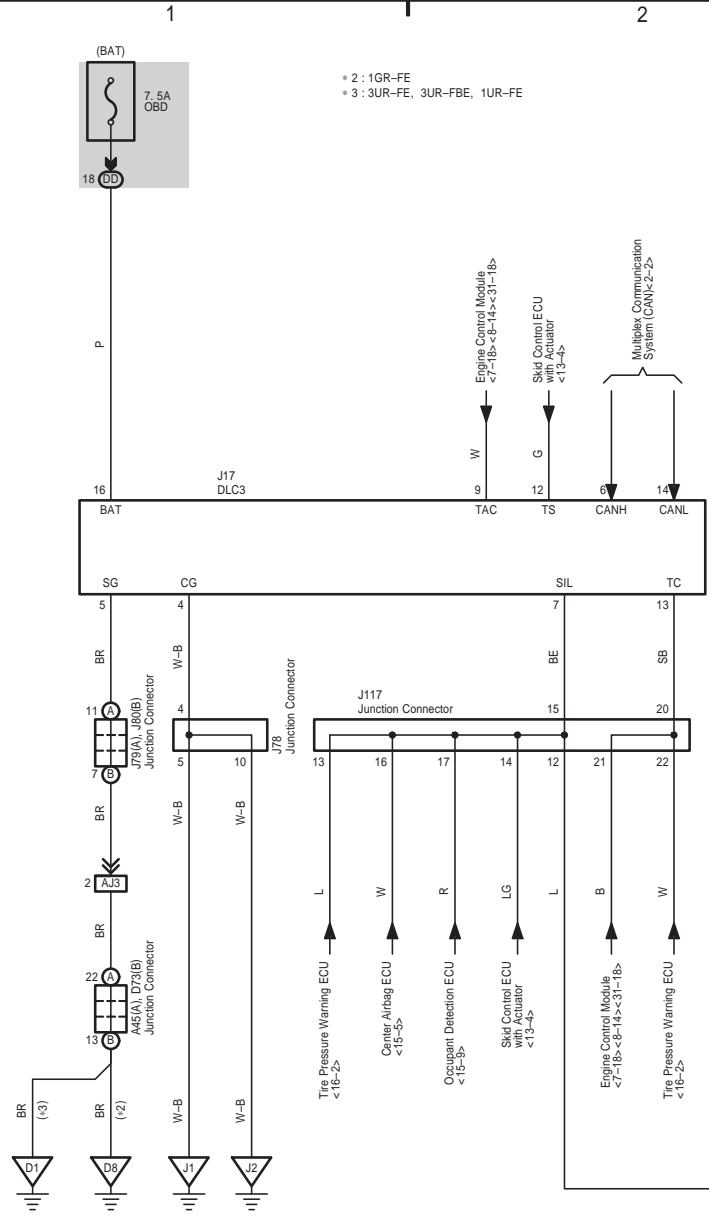

## Engine Immobiliser System

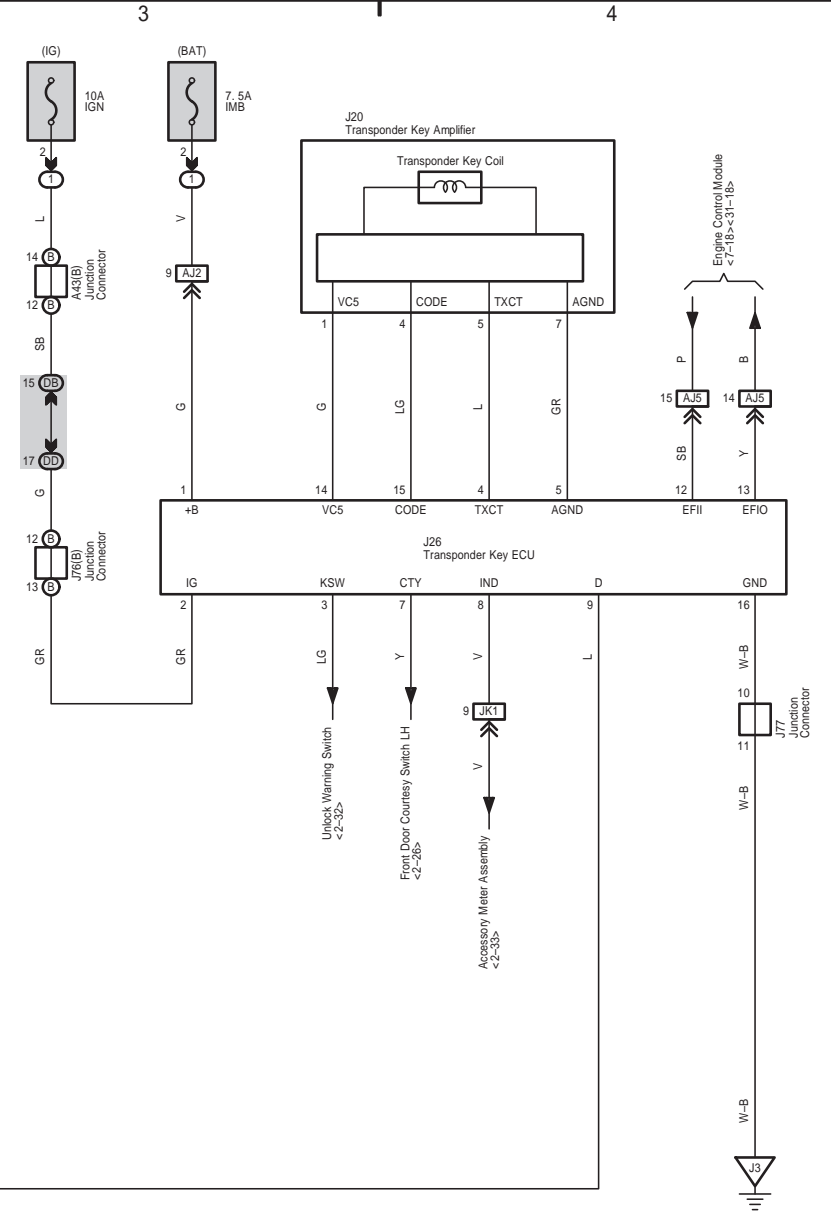

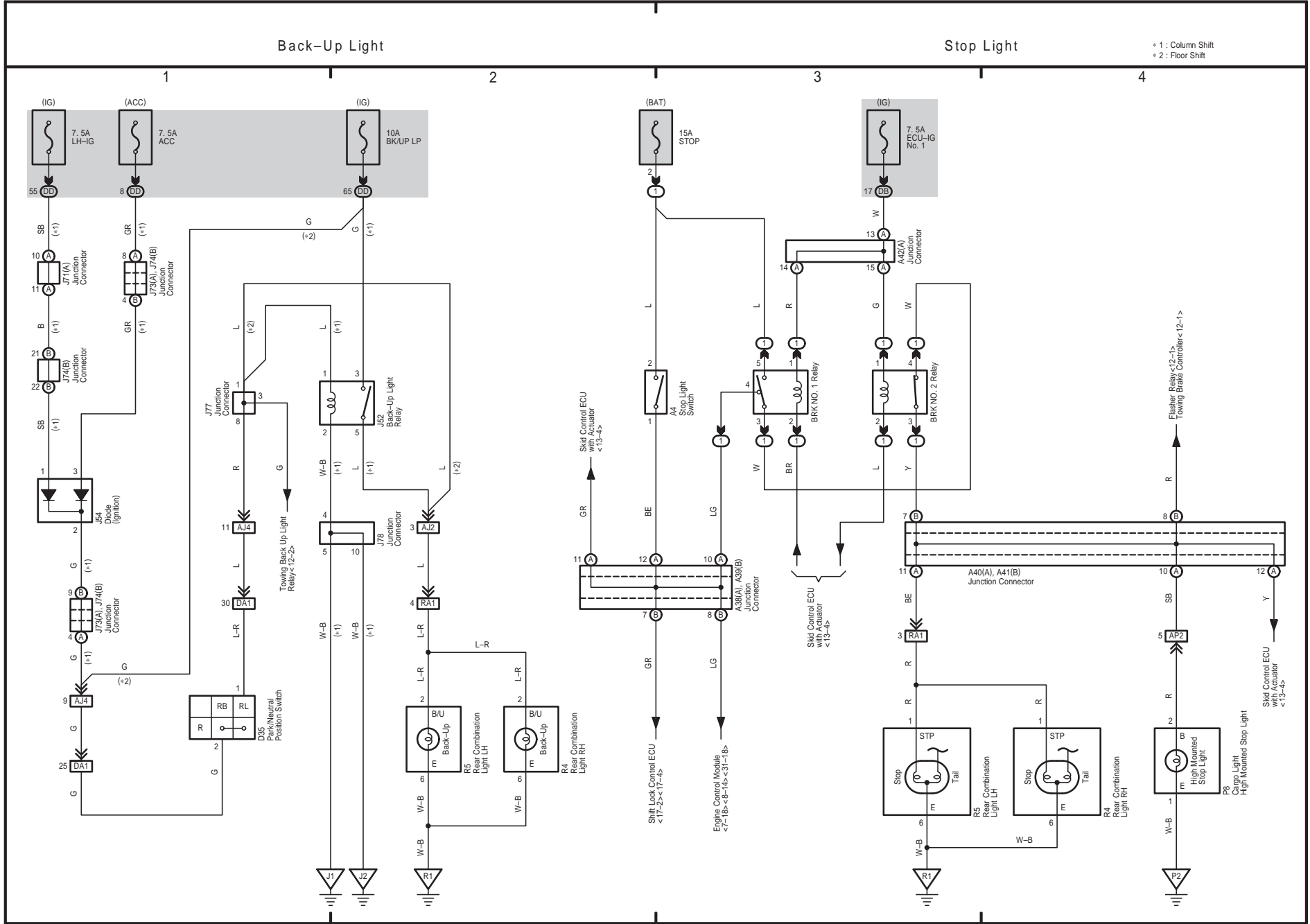

# 11 TOYOTA TUNDRA

## Turn Signal and Hazard Warning Light

\* 1 : w/ Daytime Running Light  
 \* 2 : w/ Seat Position Memory

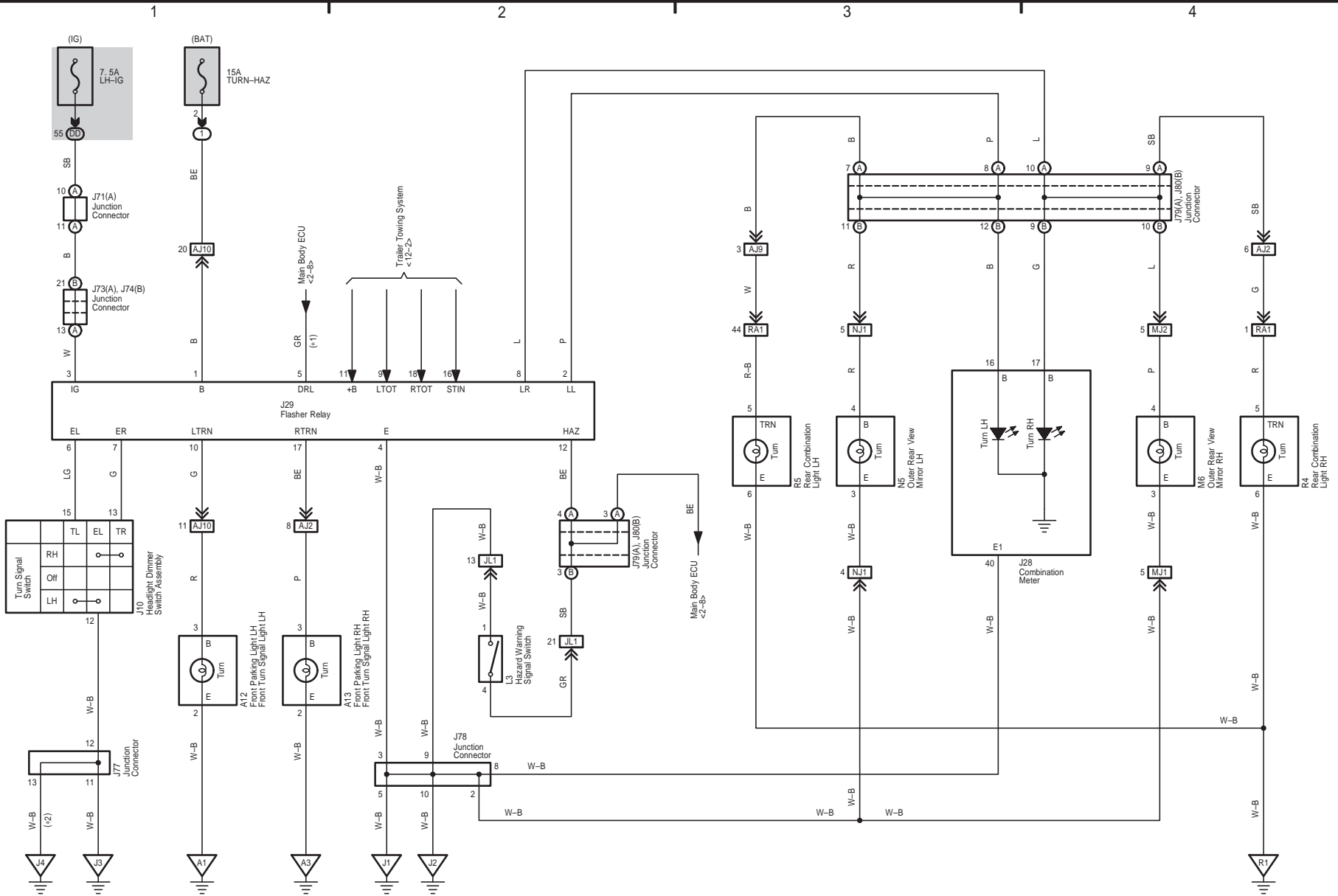

TOYOTA TUNDRA (EM16G1U)

Trailer Towing

- \* 1 : Towing Package
- \* 2 : Except Towing Package
- \* 3 : 3UR-FE, 3UR-FBE, 1UR-FE
- \* 4 : 1GR-FE

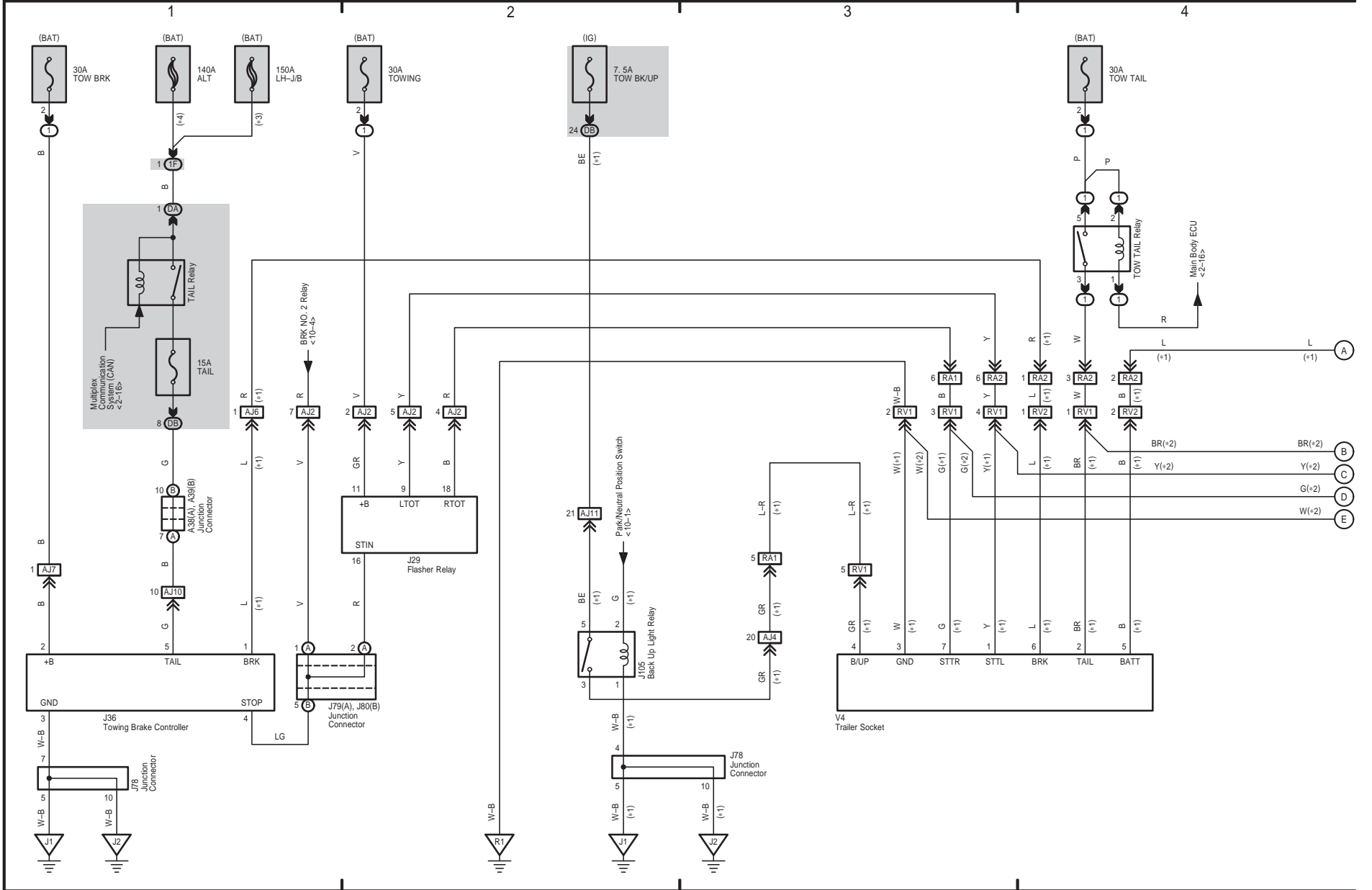



Trailer Towing

\* 1 : Towing Package  
 \* 2 : Except Towing Package

5 6 7 8

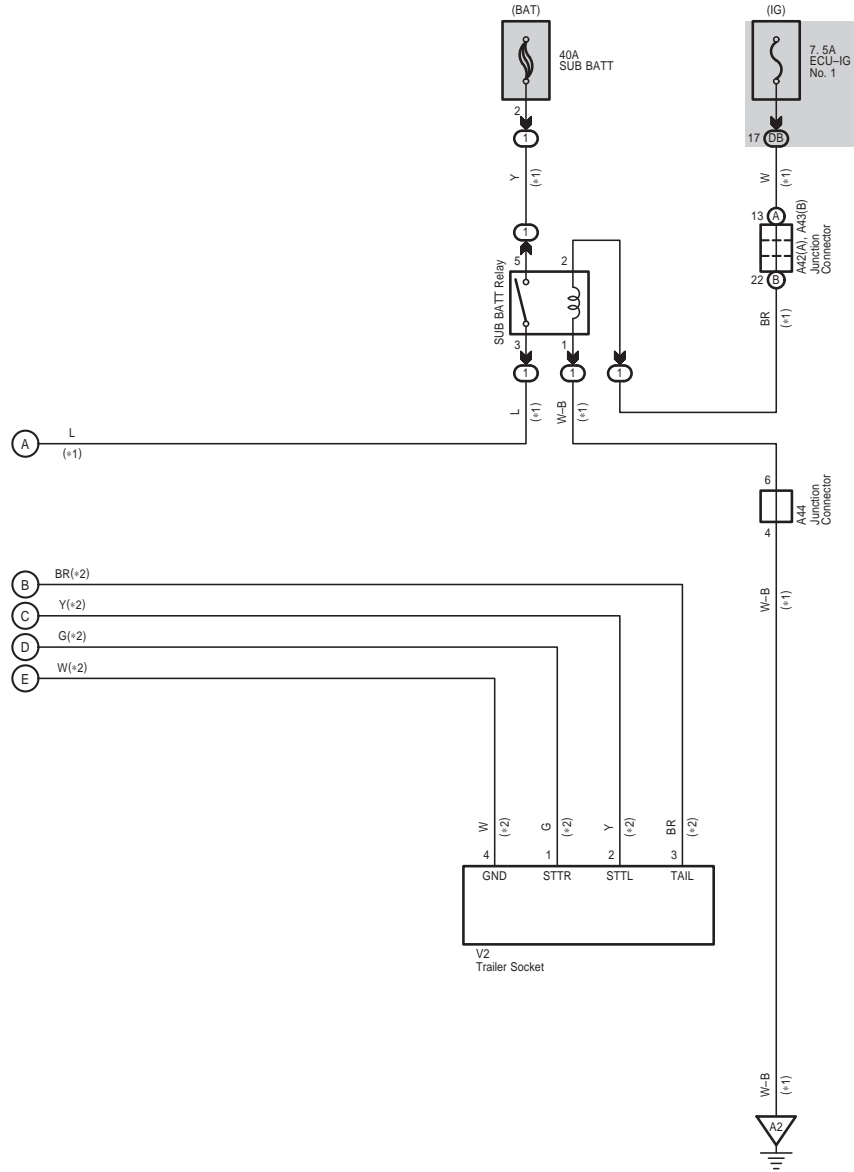

TOYOTA TUNDRA (EM16G1U)

ABS, TRAC, VSC and Auto LSD

TOYOTA TUNDRA (EM16G1U)

M OVERALL ELECTRICAL WIRING DIAGRAM

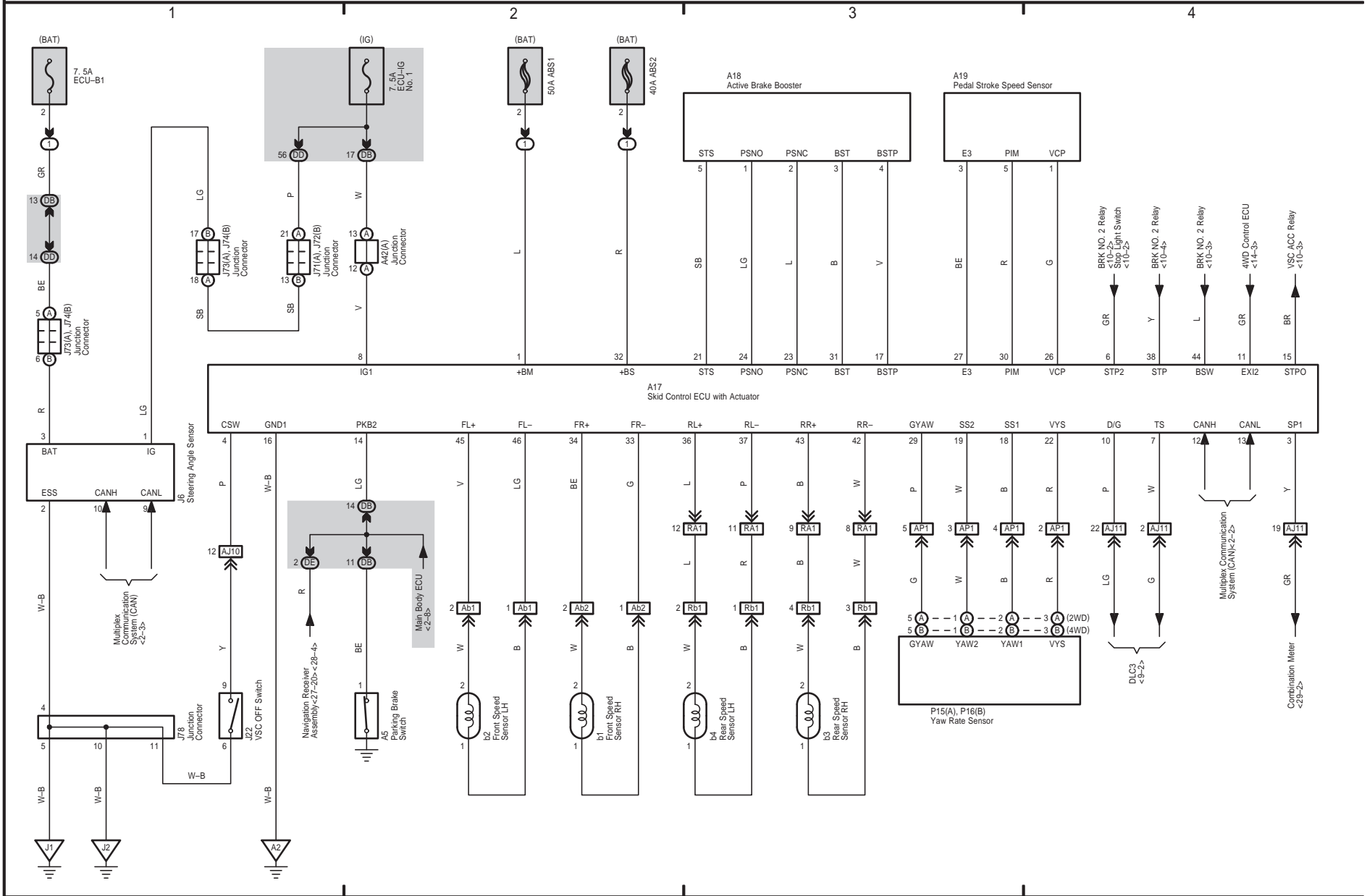

ABS, TRAC, VSC and Auto LSD

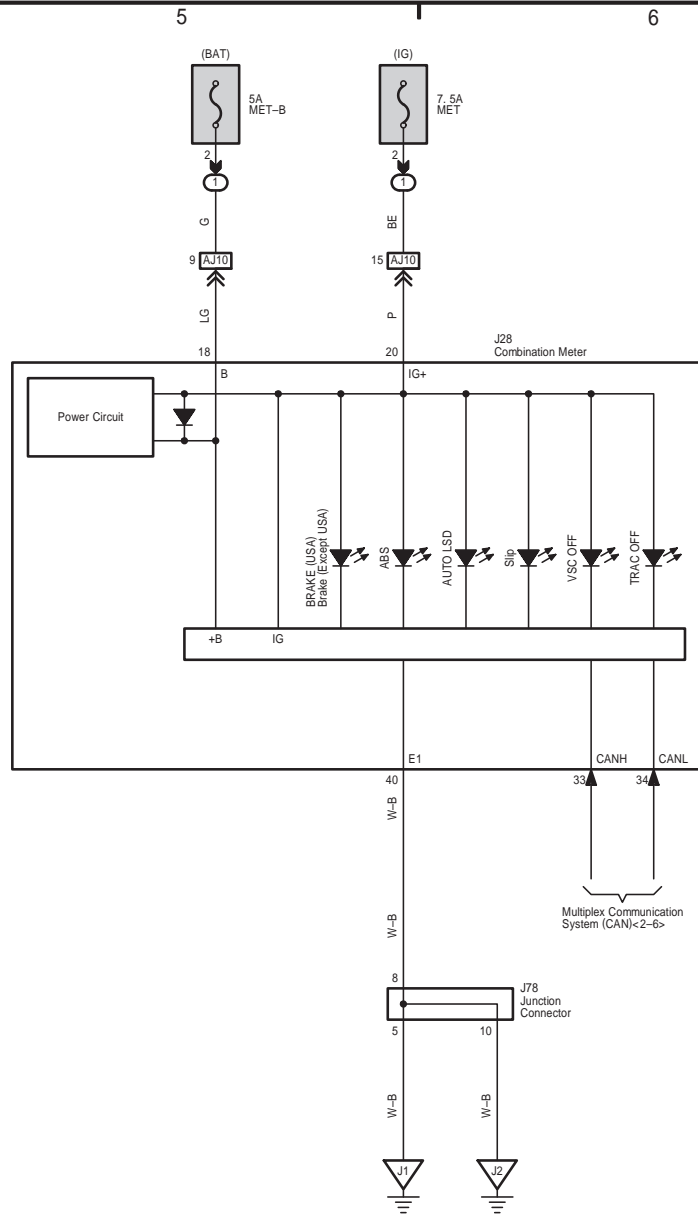

TOYOTA TUNDRA (EM16G1U)



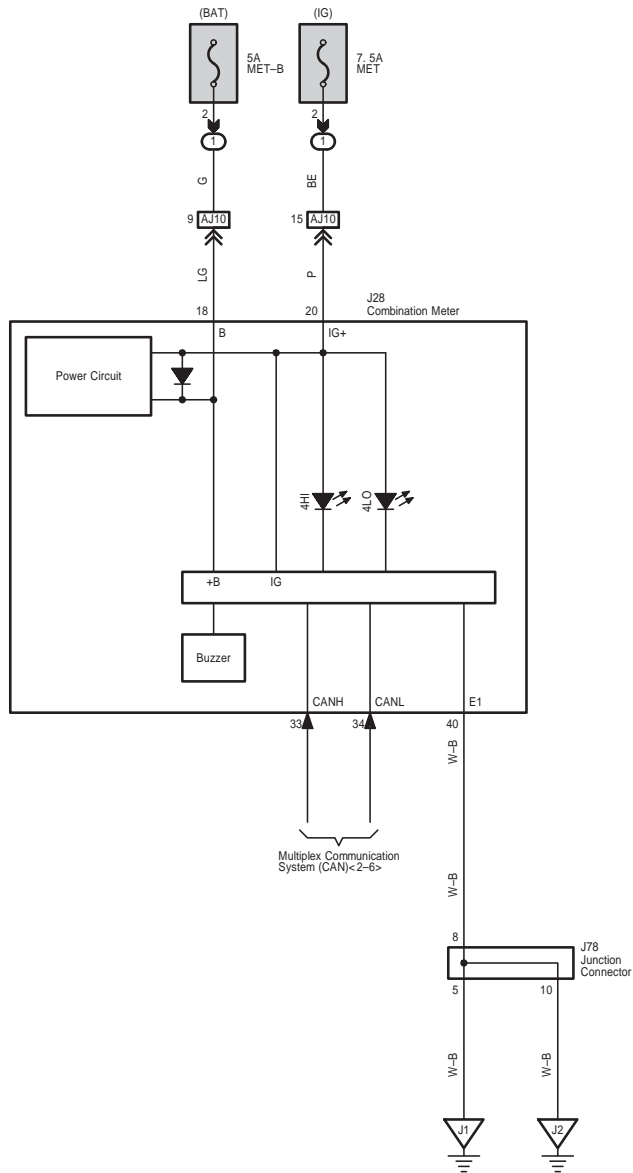

TOYOTA TUNDRA (EM16G1U)

SRS

\* 1 : w/ Airbag Cutoff Switch

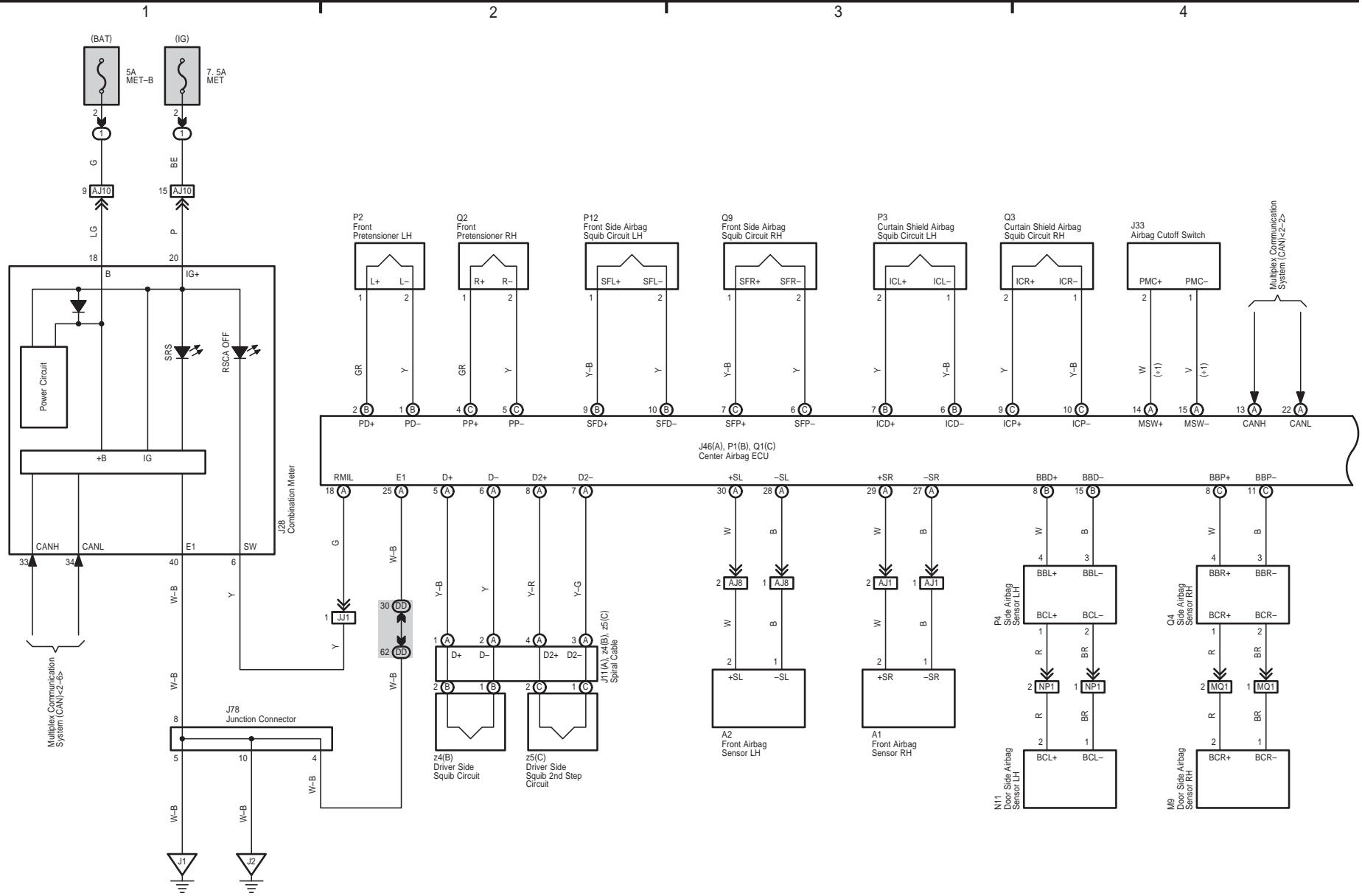

TOYOTA TUNDRA (EM16G1U)

SRS

- \* 1 : w/ Airbag Cutoff Switch
- \* 3 : w/ Power Seat
- \* 4 : w/o Power Seat
- \* 6 : w/ Curtain Airbag Cutoff Switch

TOYOTA TUNDRA (EM16G1U)

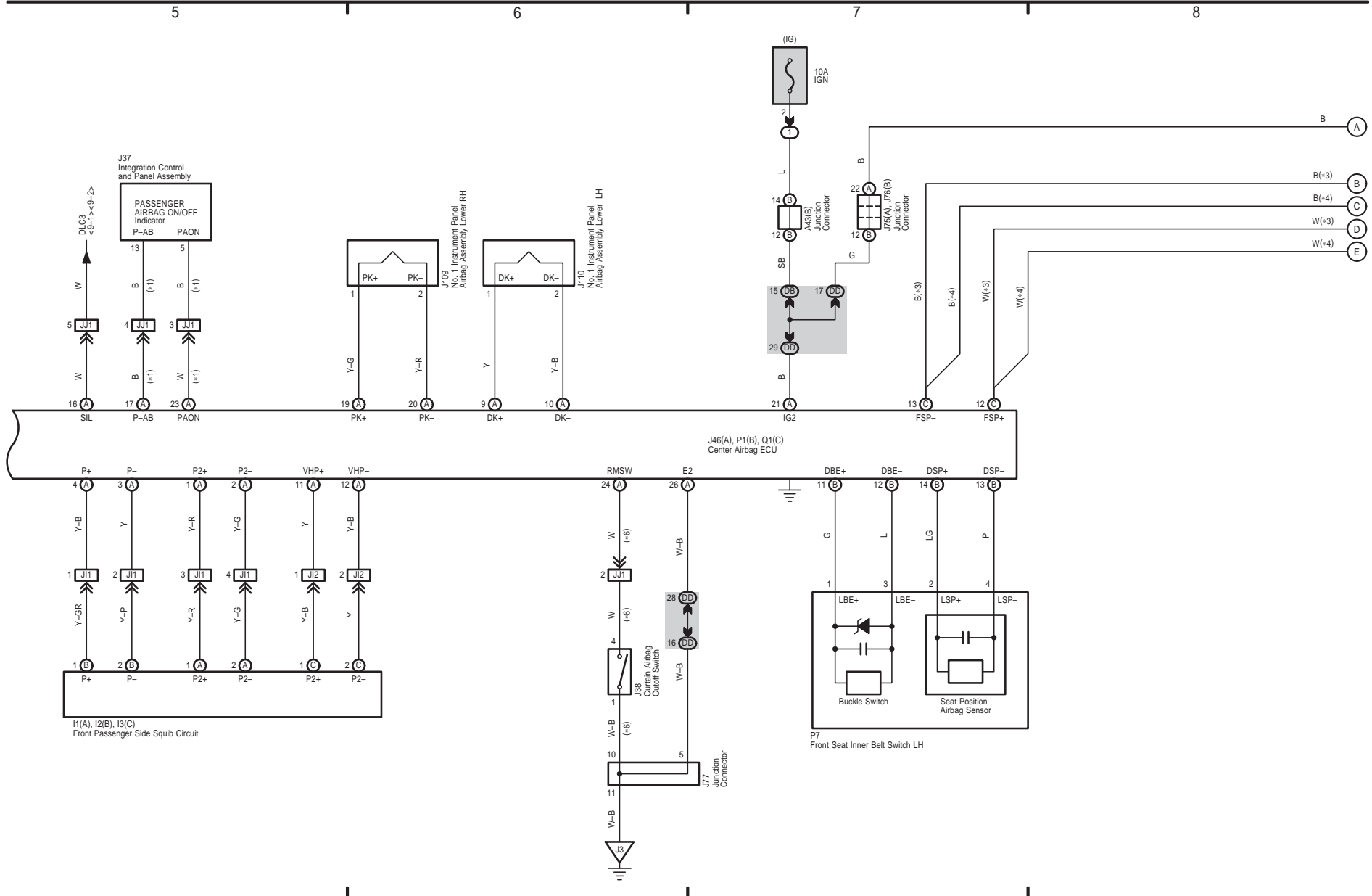

TOYOTA TUNDRA (EM16G1U)

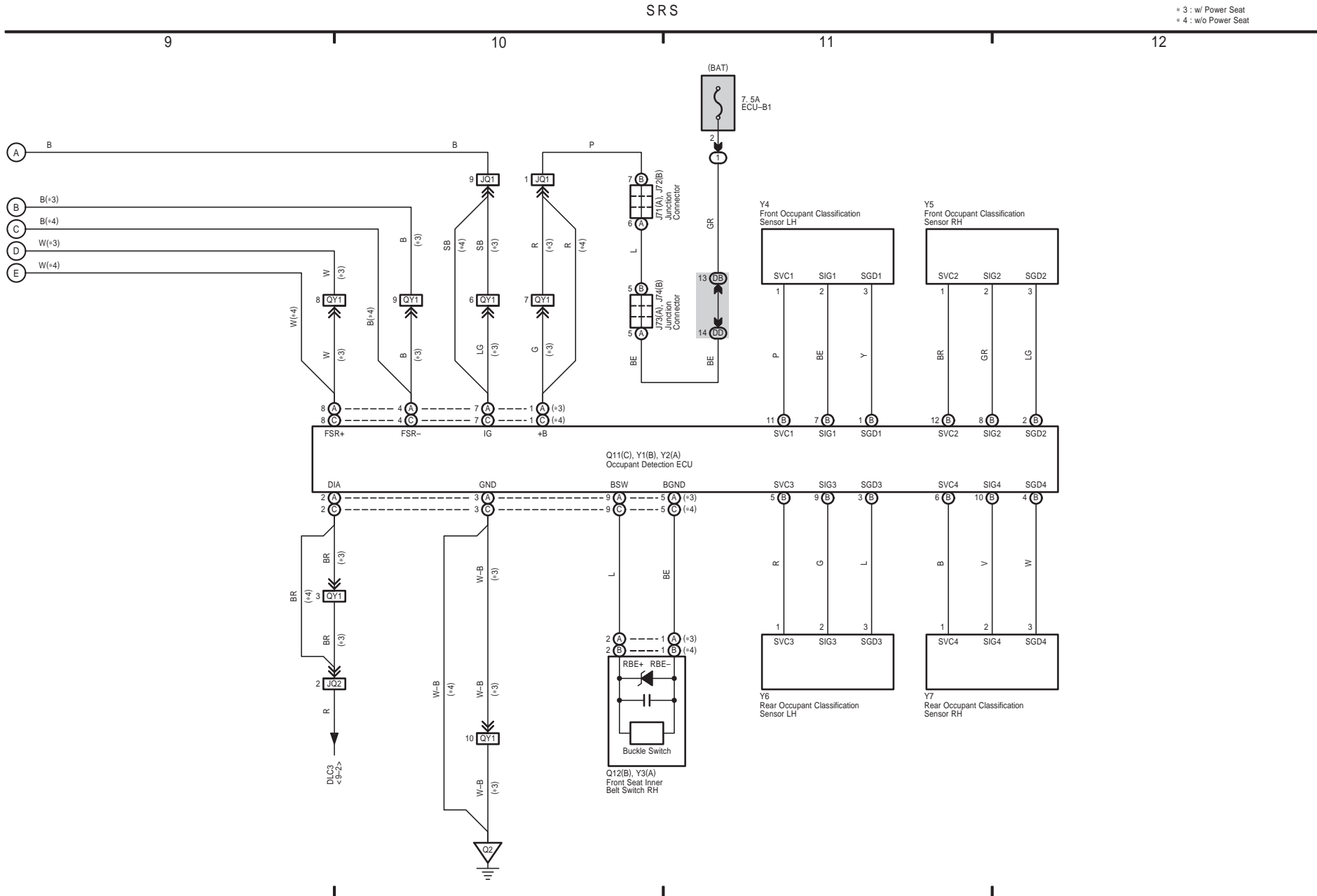



Tire Pressure Warning System

Horn

\* 1 : w/ Steering Pad Switch  
 \* 2 : w/o Steering Pad Switch

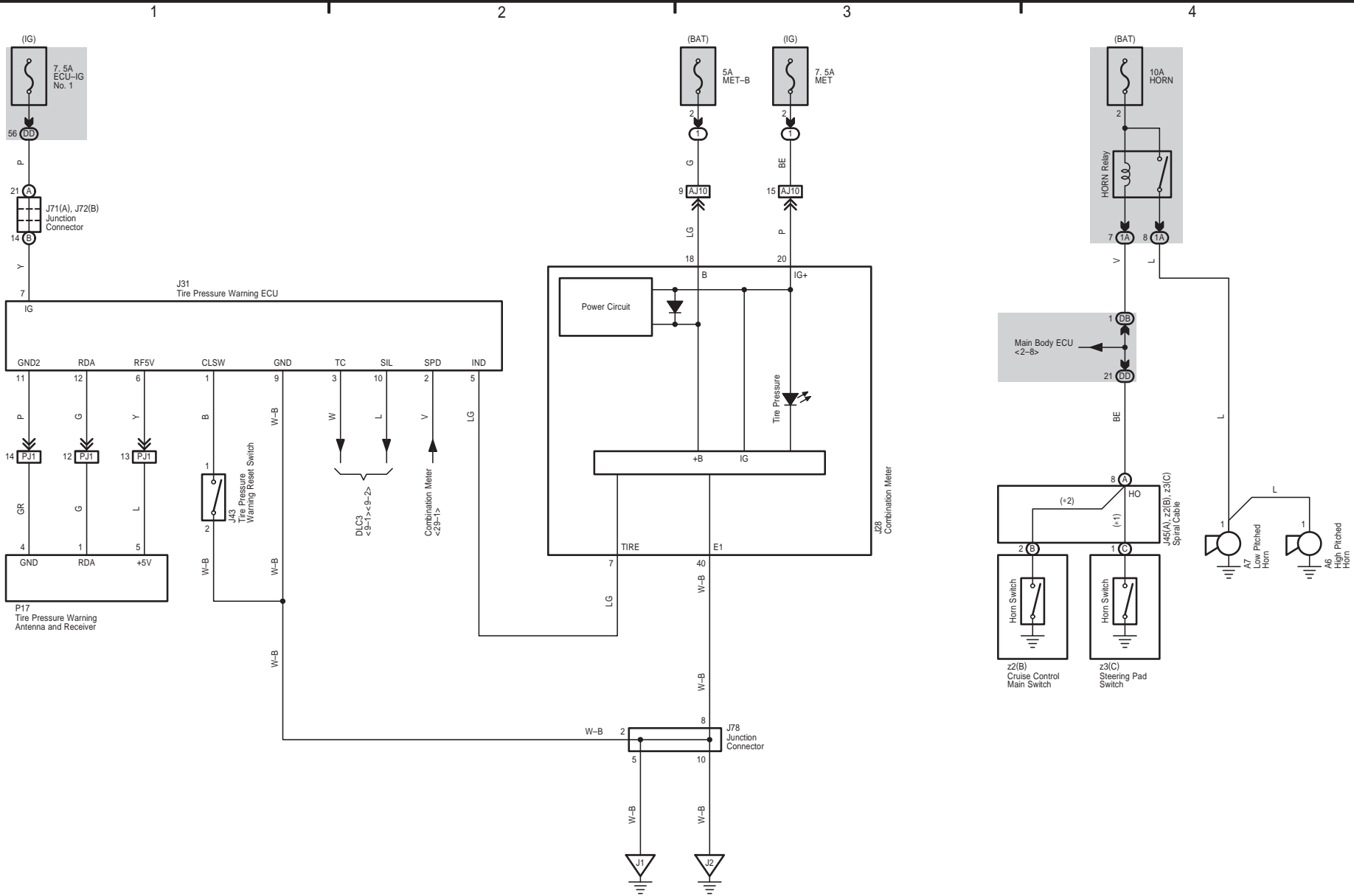

Shift Lock (Floor Shift)

Shift Lock (Column Shift)

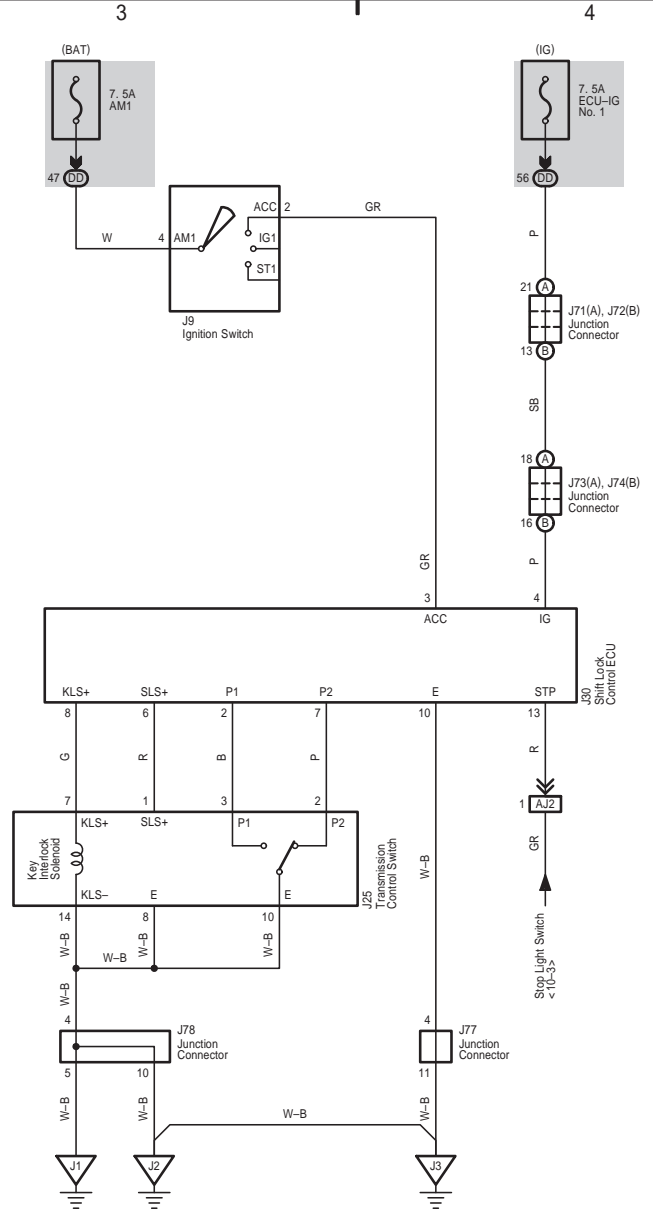
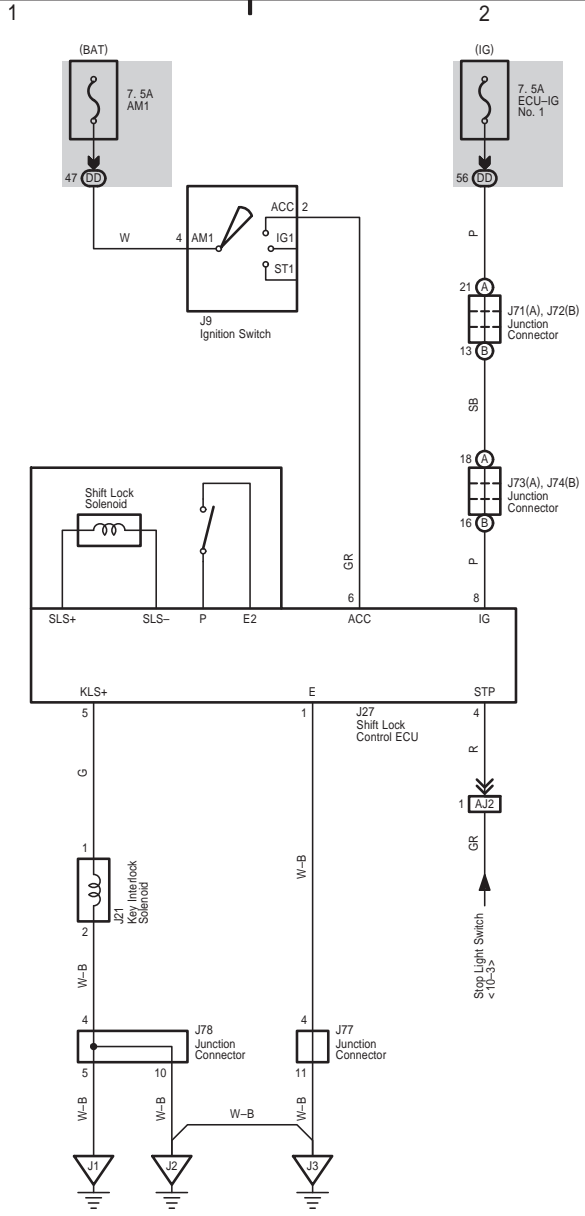

Front Wiper and Washer (w/ Intermittent Wiper)

Front Wiper and Washer (w/o Intermittent Wiper)

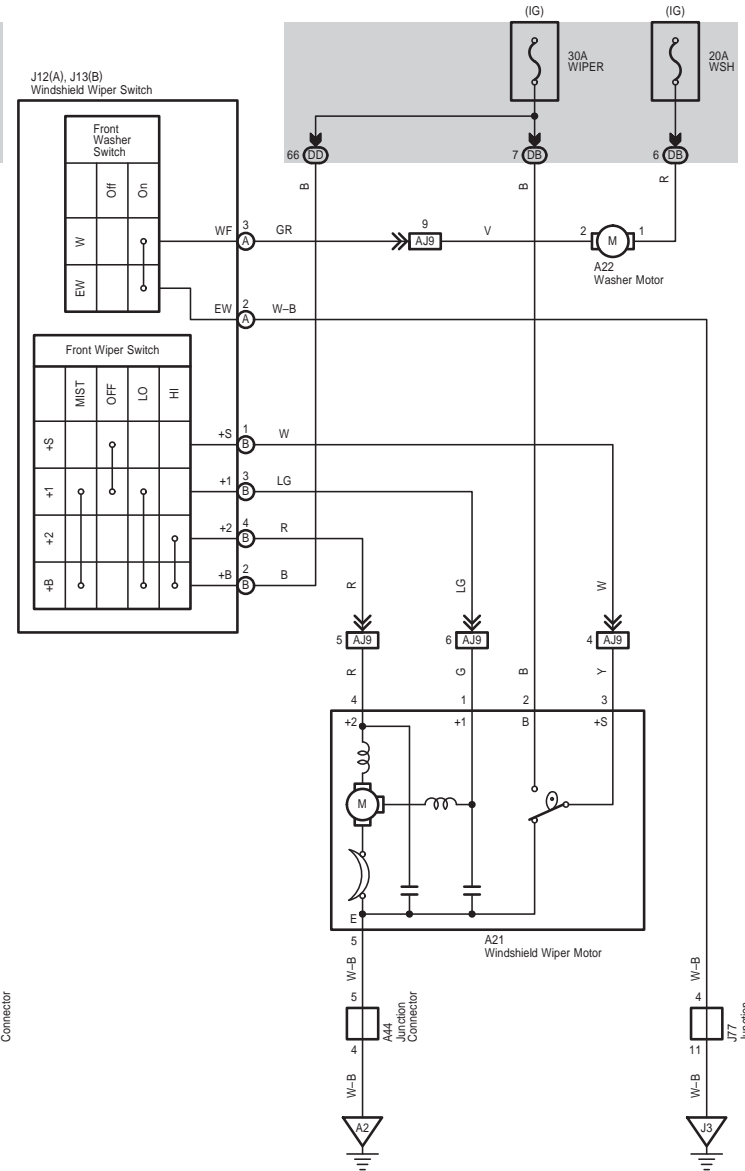
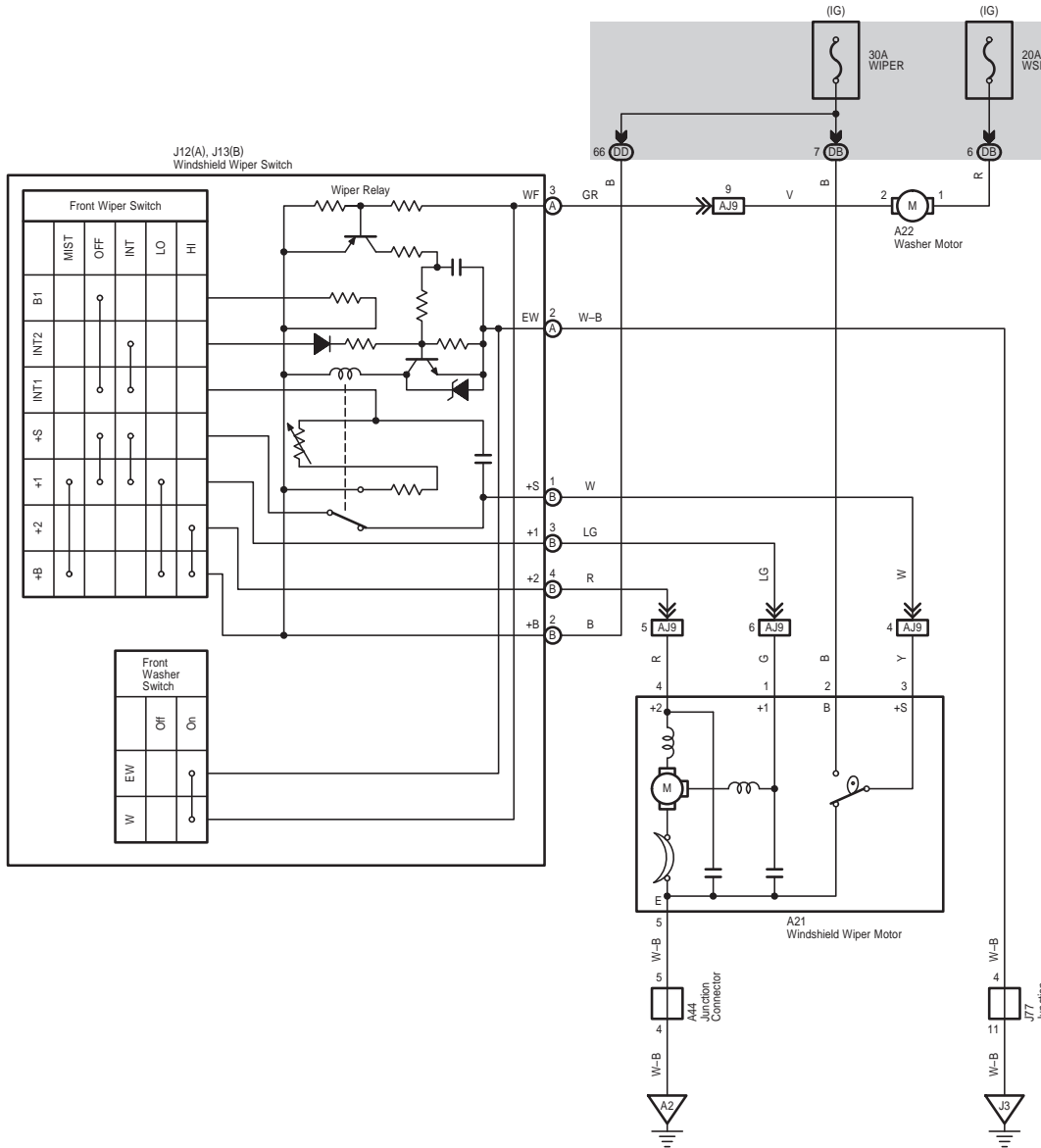

19 TOYOTA TUNDRA

Automatic Glare-Resistant EC Mirror with Compass and Garage Door Opener

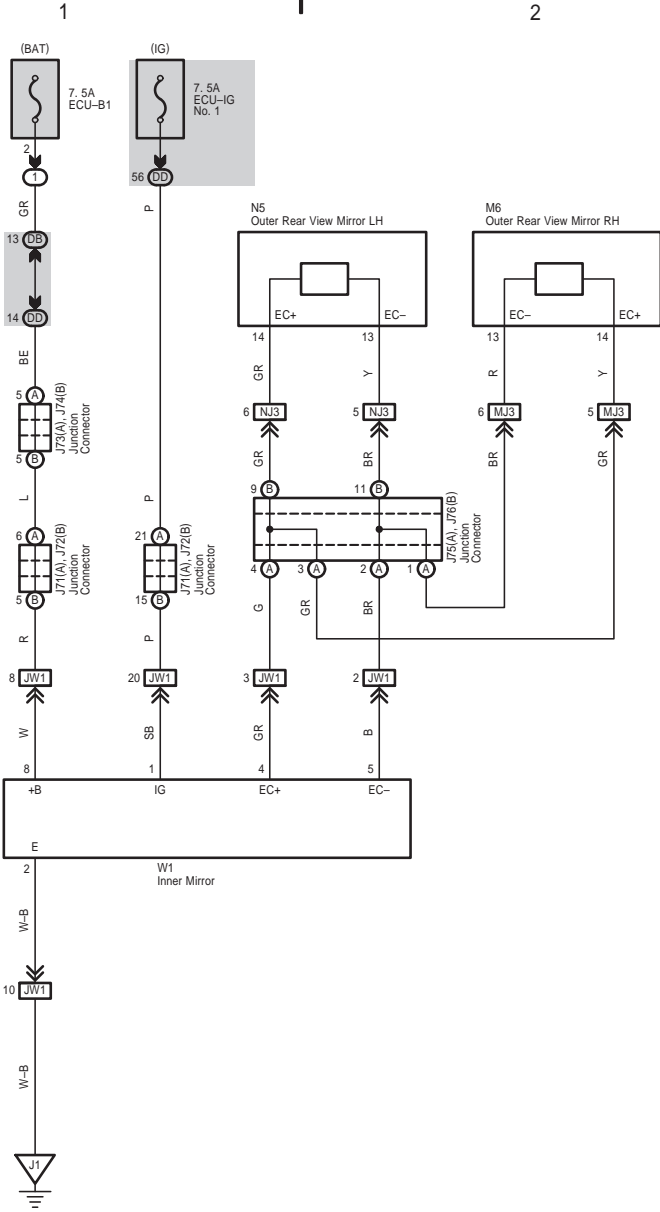

Mirror Heater

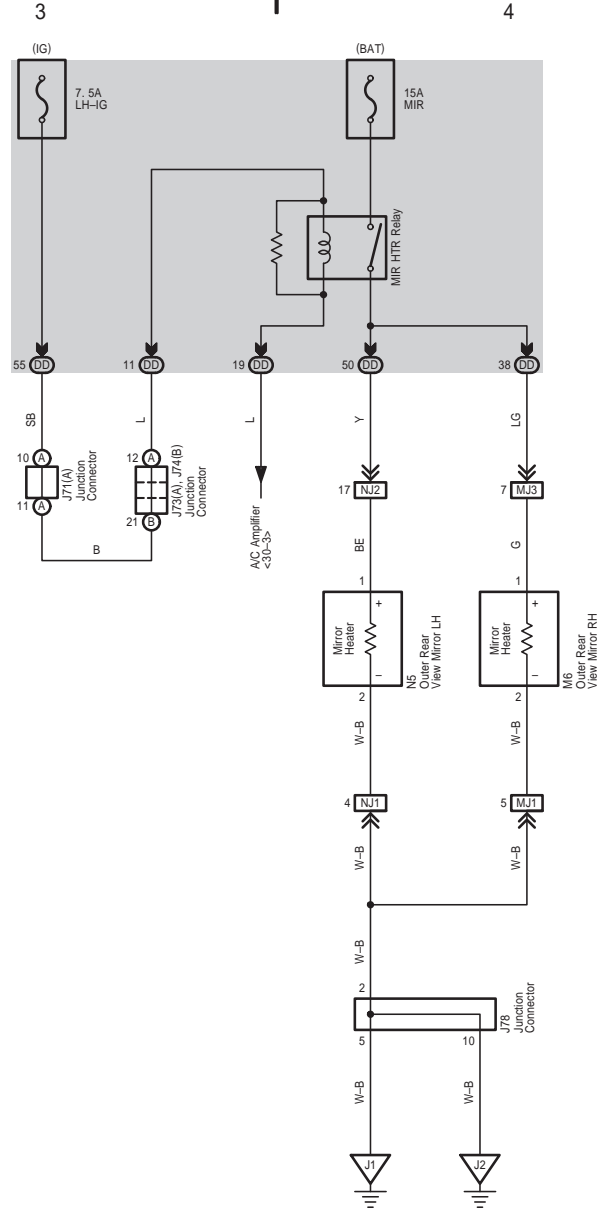

Power Tilt and Power Telescopic

Front Window Deicer

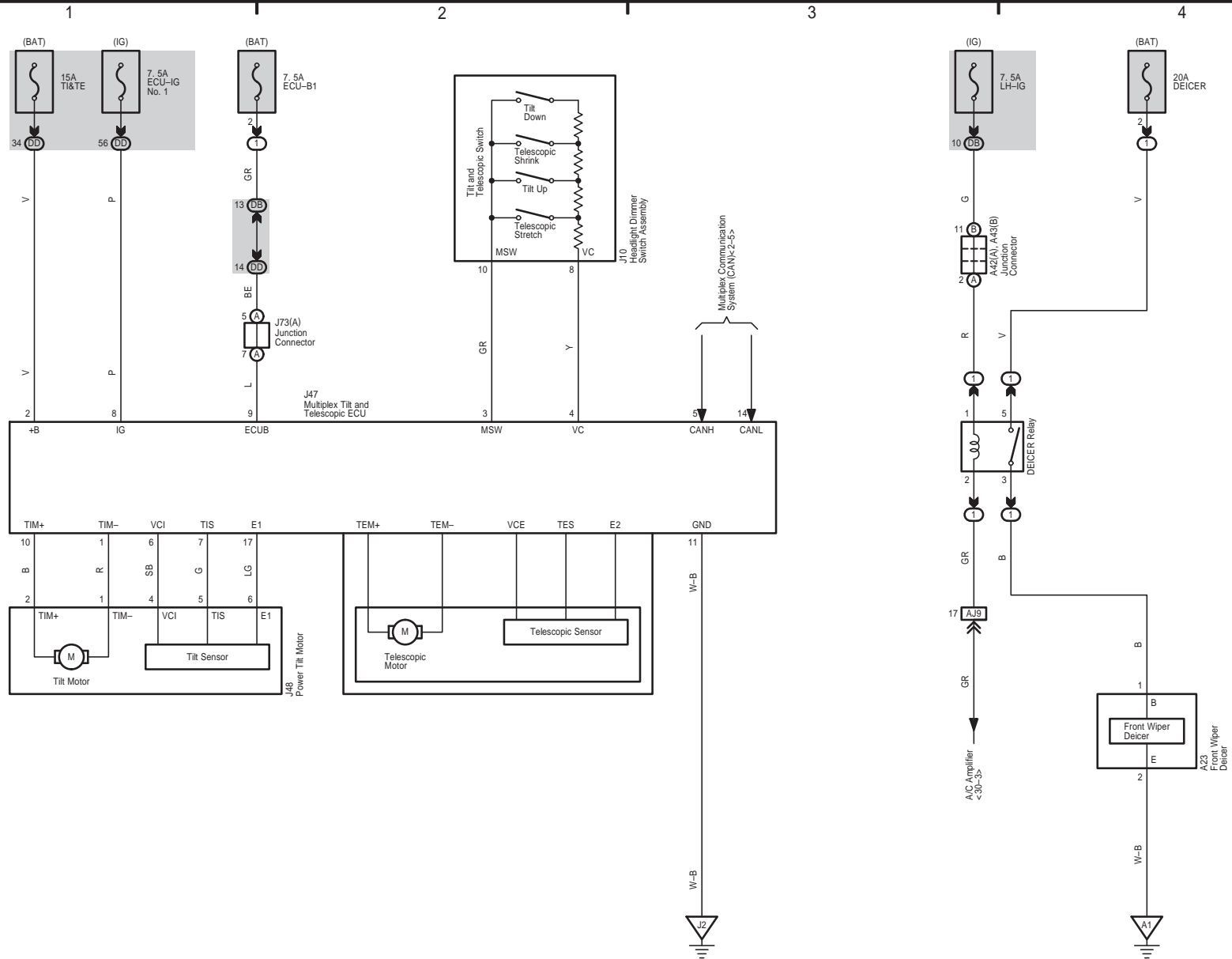

Power Seat (Driver' s Seat w/ Seat Position Memory)

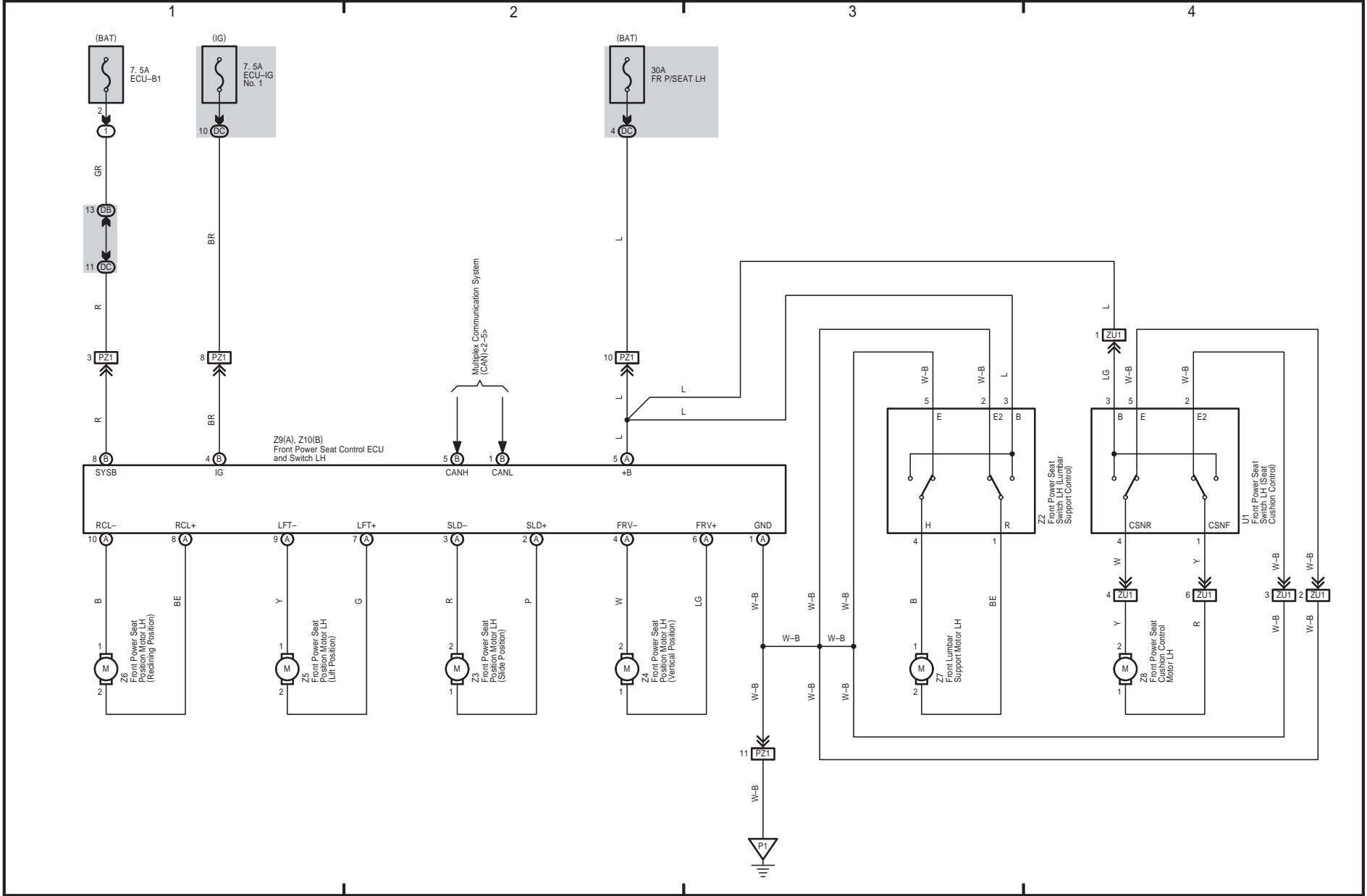



Power Seat (Front Passenger's Seat)

Seat Heater (w/o Climate Control Seat)

1 2 3 4

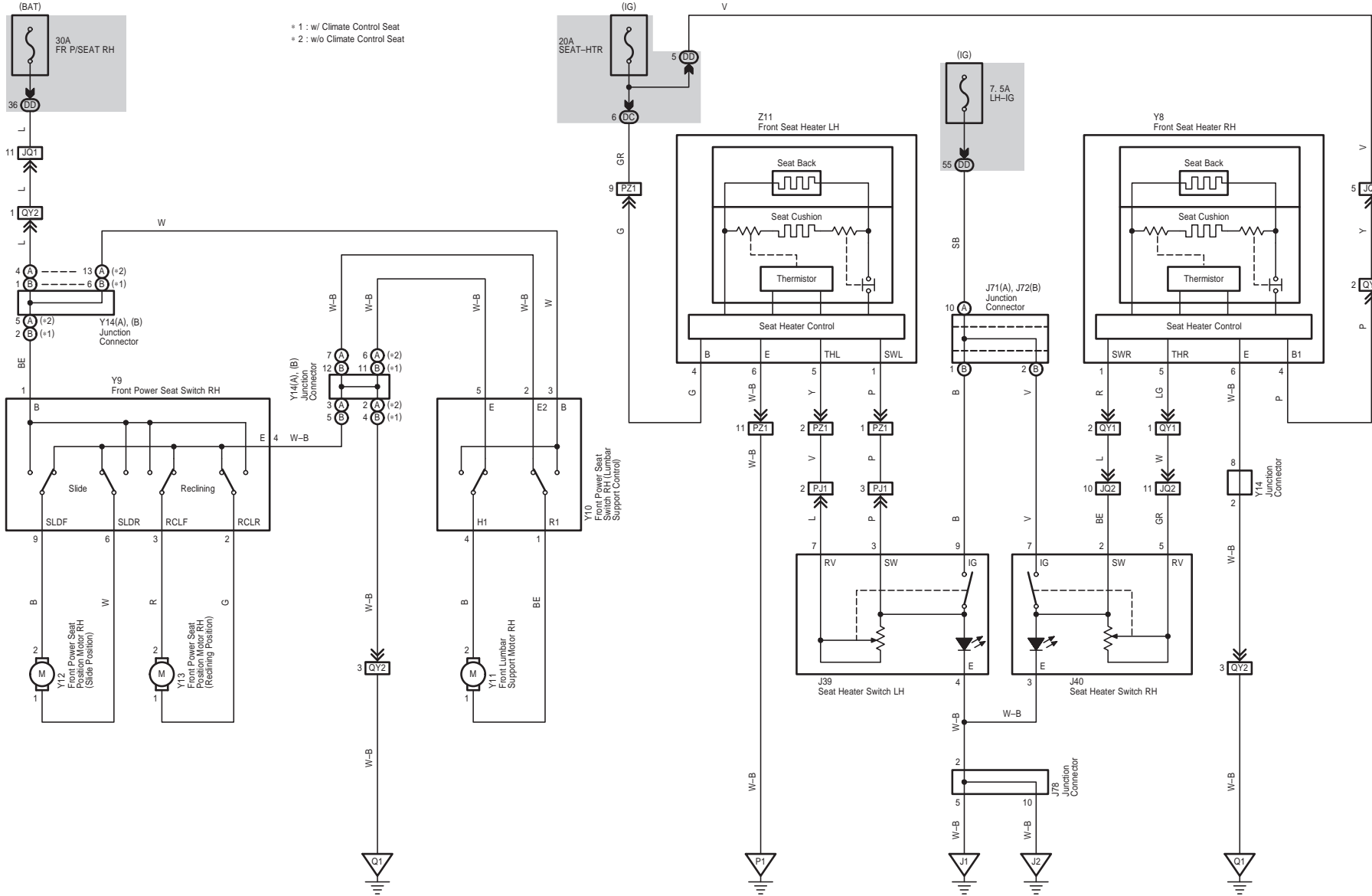

TOYOTA TUNDRA (EM16G1U)



Remote Control Mirror (w/o Seat Position Memory)

\* 1 : w/ Retractor

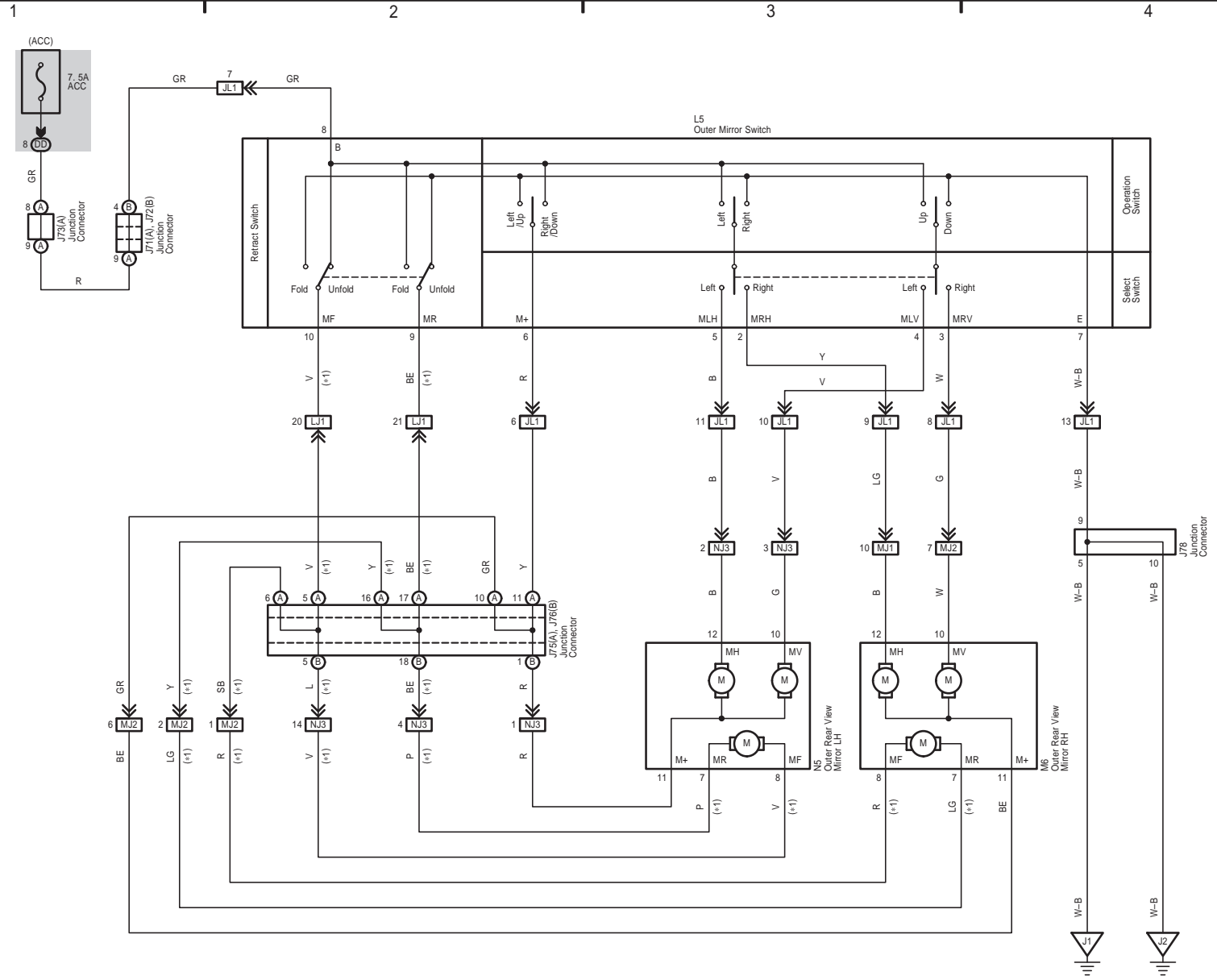

TOYOTA TUNDRA (EM16G1U)



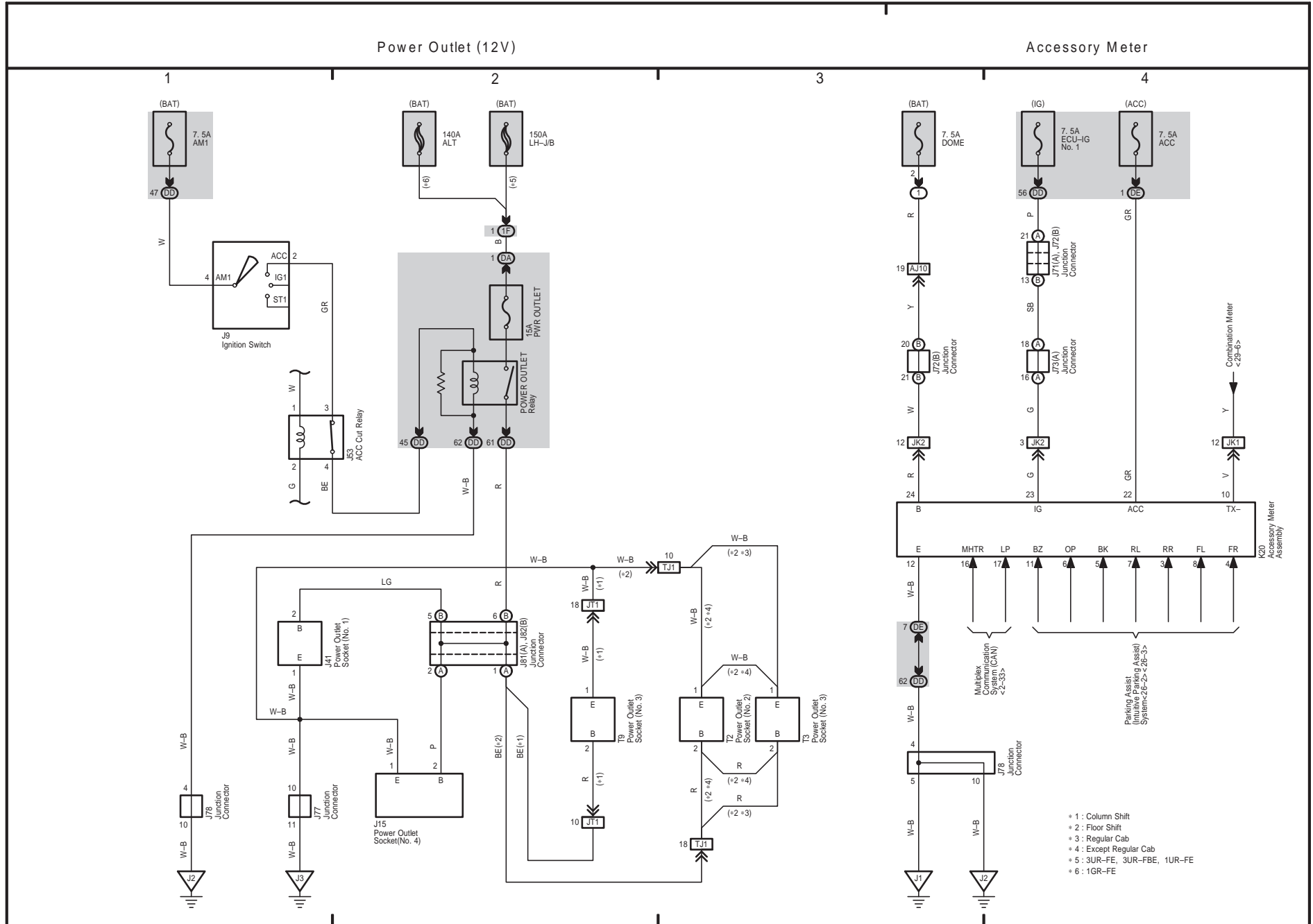







Audio System (Separate Type Amplifier), Navigation System (Separate Type Amplifier)  
and Parking Assist (Rear View Monitor w/ Navigation System) (Separate Type Amplifier)

TOYOTA TUNDRA (EM16G1U)

M OVERALL ELECTRICAL WIRING DIAGRAM

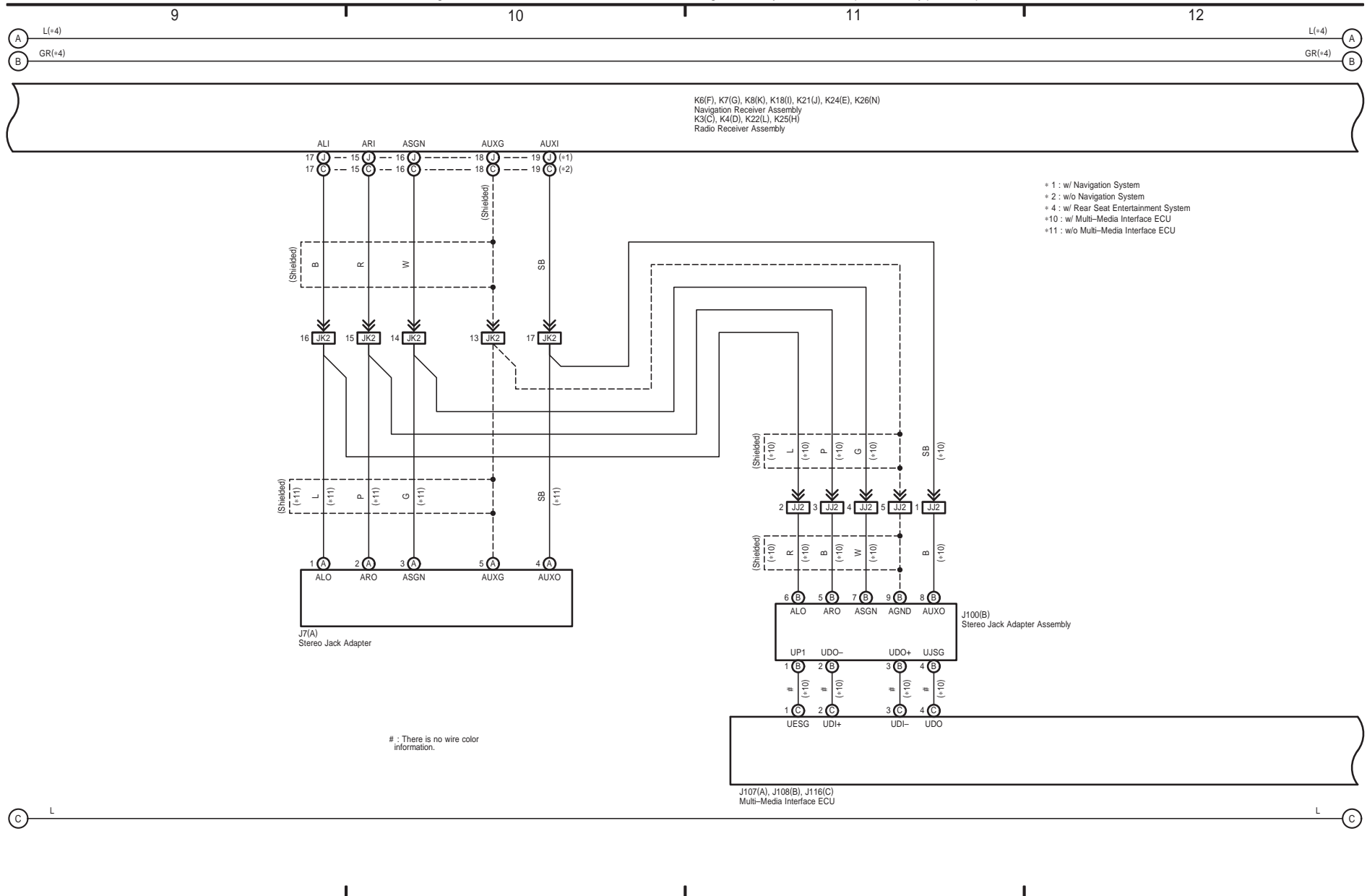

Audio System (Separate Type Amplifier), Navigation System (Separate Type Amplifier)  
and Parking Assist (Rear View Monitor w/ Navigation System) (Separate Type Amplifier)

TOYOTA TUNDRA (EM16G1U)

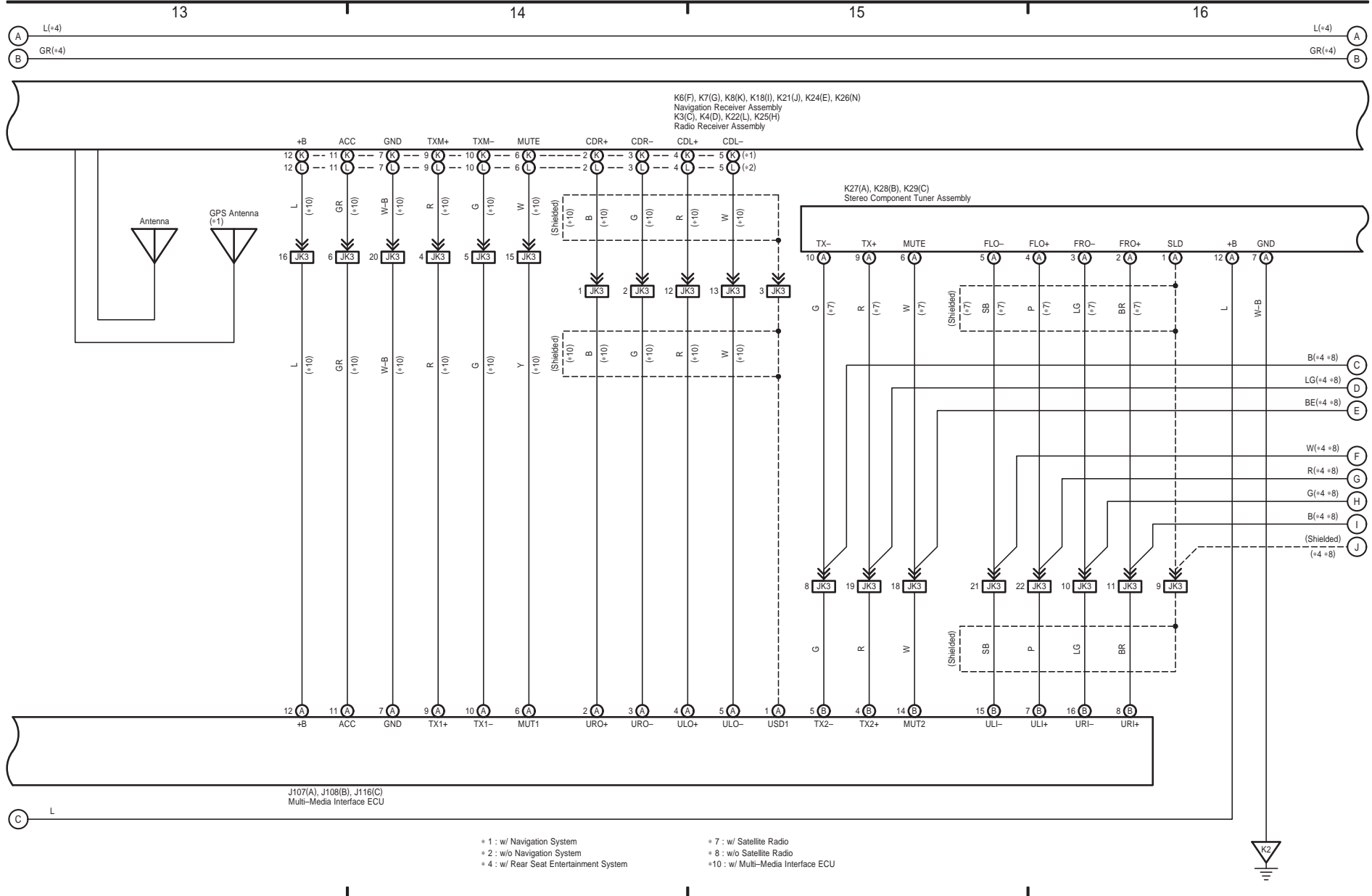

\* 1 : w/ Navigation System  
\* 2 : w/o Navigation System  
\* 4 : w/ Rear Seat Entertainment System  
\* 7 : w/ Satellite Radio  
\* 8 : w/o Satellite Radio  
\* 10 : w/ Multi-Media Interface ECU



Audio System (Separate Type Amplifier), Navigation System (Separate Type Amplifier)  
and Parking Assist (Rear View Monitor w/ Navigation System) (Separate Type Amplifier)

TOYOTA TUNDRA (EM16G1U)

M OVERALL ELECTRICAL WIRING DIAGRAM

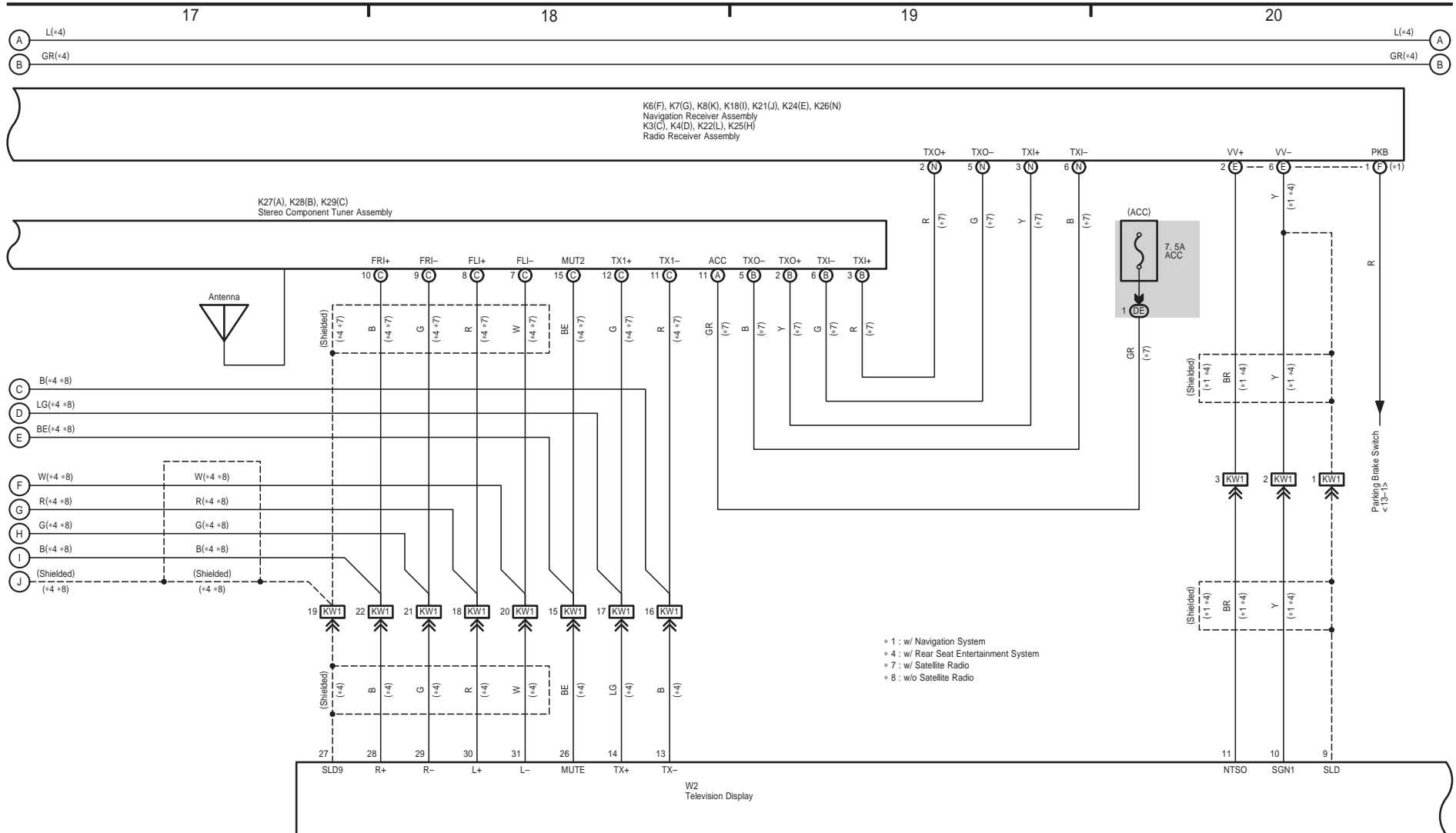



Audio System (Separate Type Amplifier), Navigation System (Separate Type Amplifier)  
and Parking Assist (Rear View Monitor w/ Navigation System) (Separate Type Amplifier)

TOYOTA TUNDRA (EM16G1U)

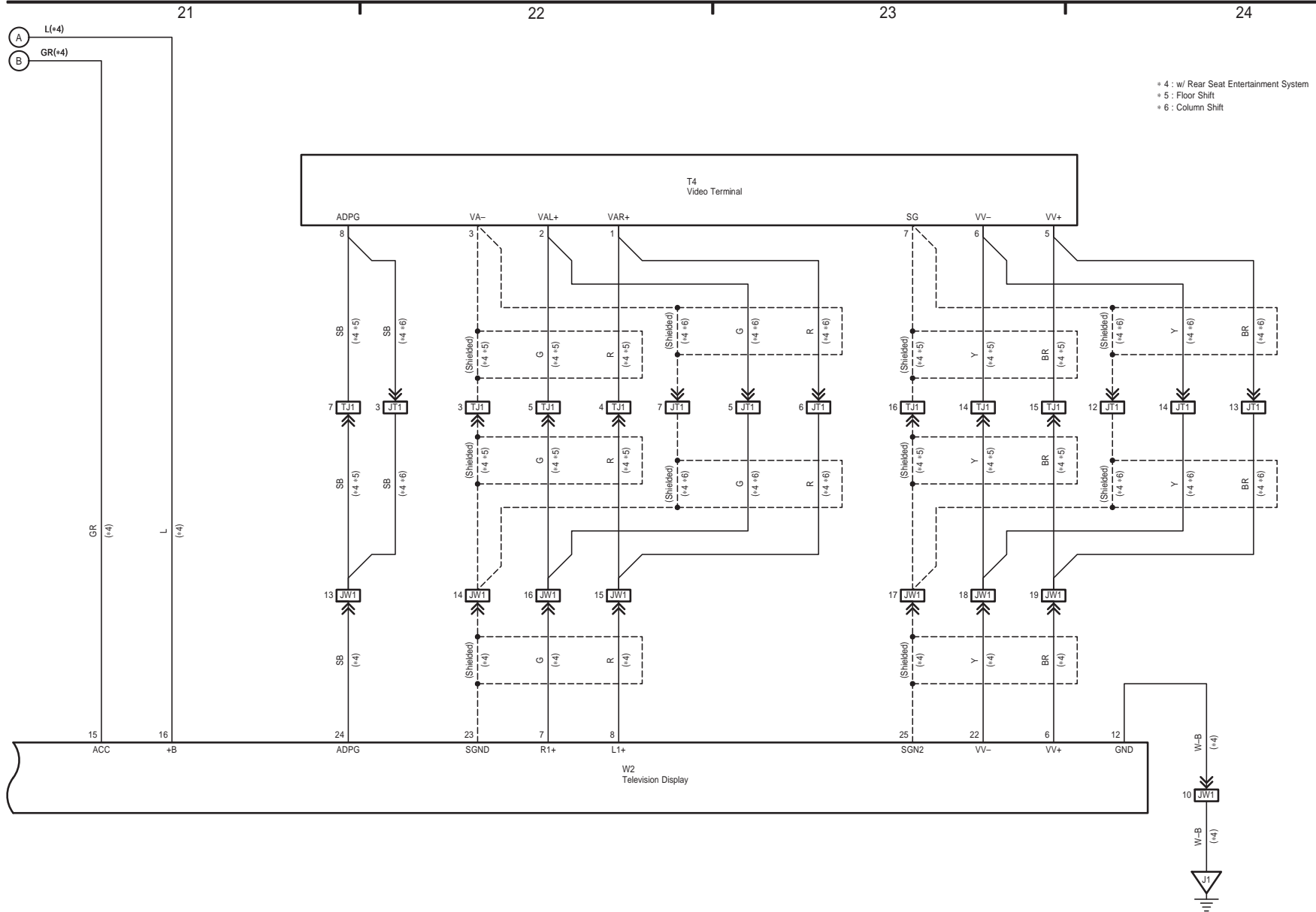

Audio System (Built-in Type Amplifier), Navigation System (Built-in Type Amplifier)  
and Parking Assist (Rear View Monitor w/ Navigation System) (Built-in Type Amplifier)

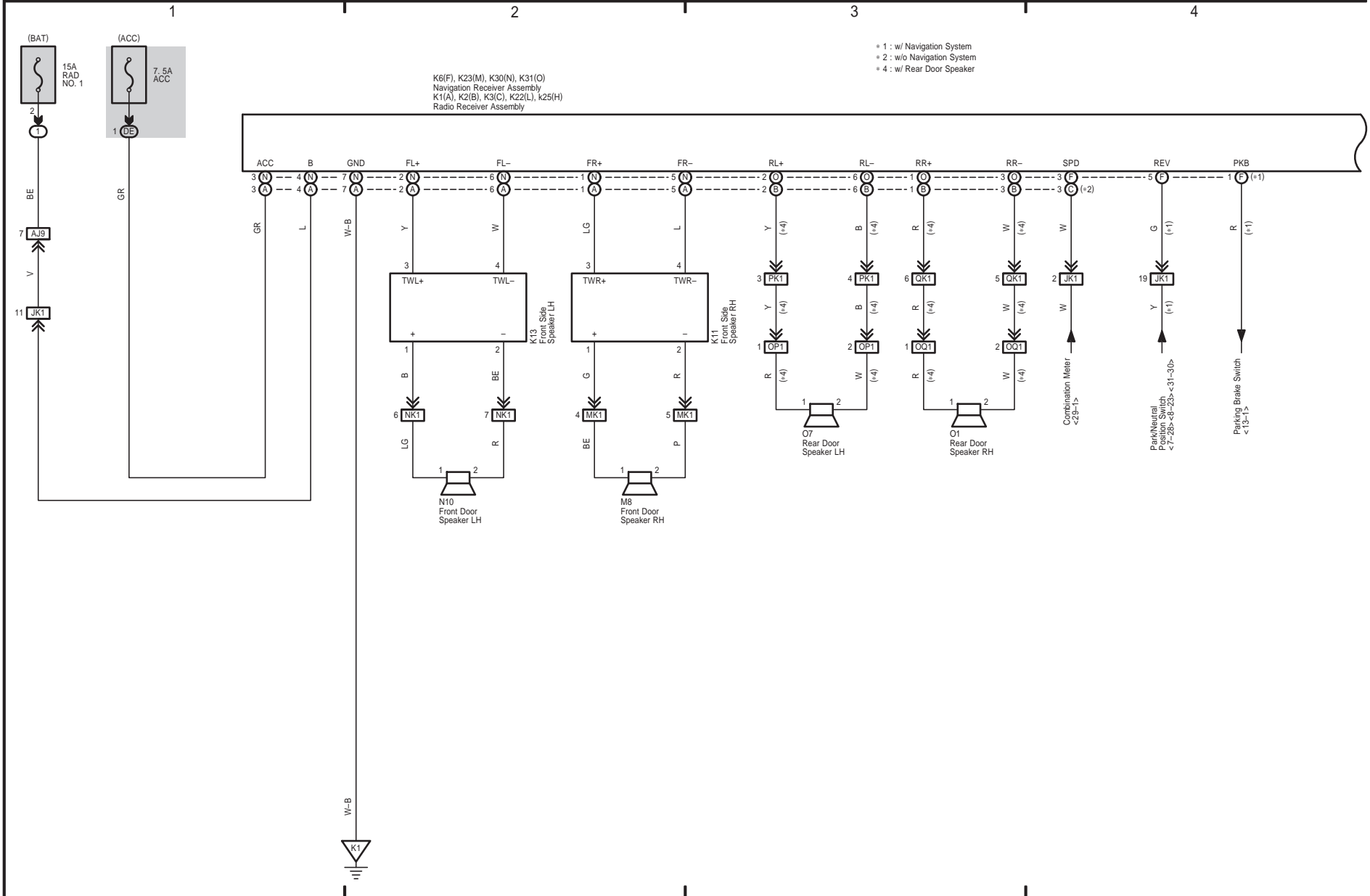

Audio System (Built-in Type Amplifier), Navigation System (Built-in Type Amplifier)  
and Parking Assist (Rear View Monitor w/ Navigation System) (Built-in Type Amplifier)

5 6 7 8

K6(F), K23(M), K30(N), K31(O)  
Navigation Receiver Assembly  
K1(A), K2(B), K3(C), K22(L), k25(H)  
Radio Receiver Assembly

- \* 1 : w/ Navigation System
- \* 2 : w/o Navigation System
- \* 3 : w/ Rear View Monitor
- \* 7 : w/ SDARS Antenna

TOYOTA TUNDRA (EM16G1U)

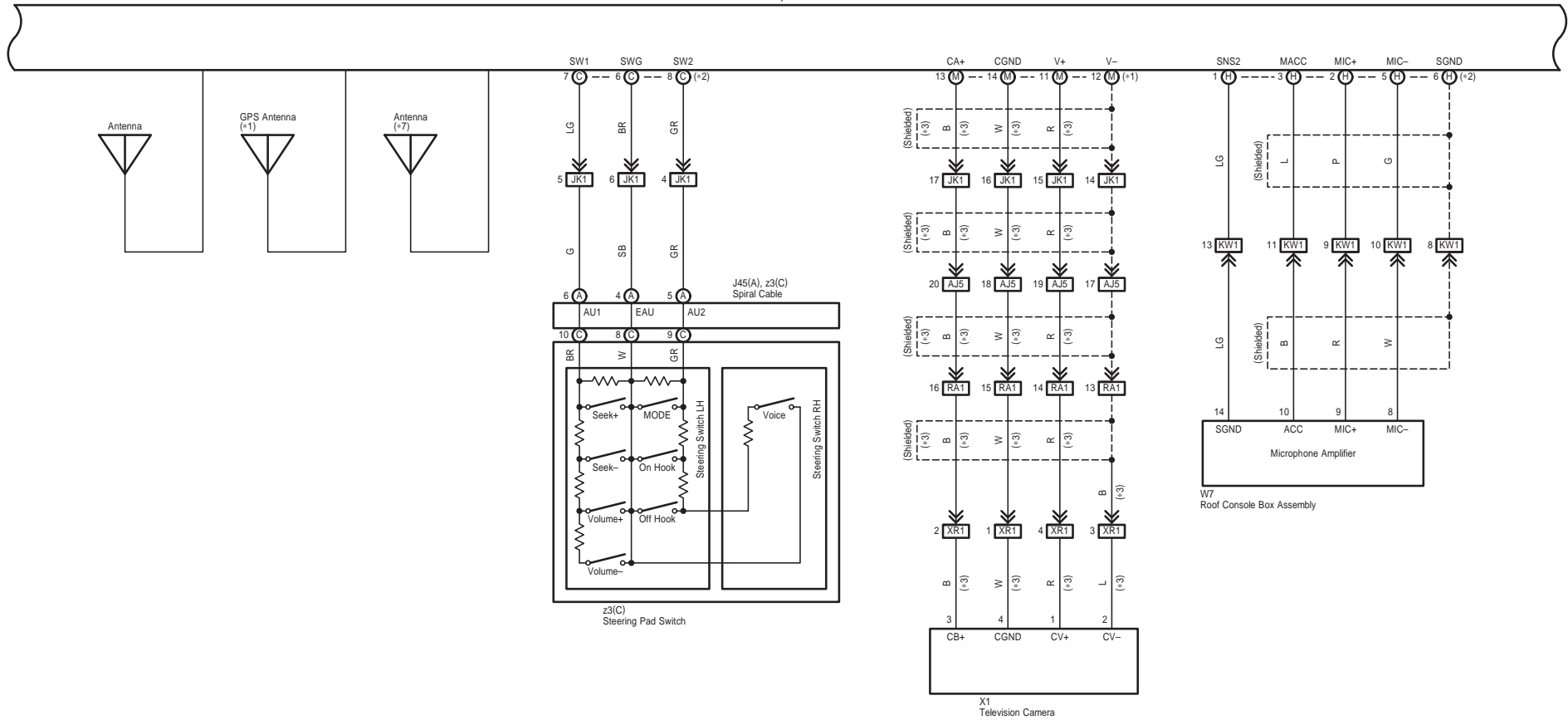

Audio System (Built-in Type Amplifier), Navigation System (Built-in Type Amplifier)  
and Parking Assist (Rear View Monitor w/ Navigation System) (Built-in Type Amplifier)

9 10 11 12

K6(F), K23(M), K30(N), K31(O)  
Navigation Receiver Assembly  
K1(A), K2(B), K3(C), K22(L), k25(H)  
Radio Receiver Assembly

- \* 1 : w/ Navigation System
- \* 2 : w/o Navigation System
- \* 5 : w/ Multi-Media Interface ECU
- \* 6 : w/o Multi-Media Interface ECU

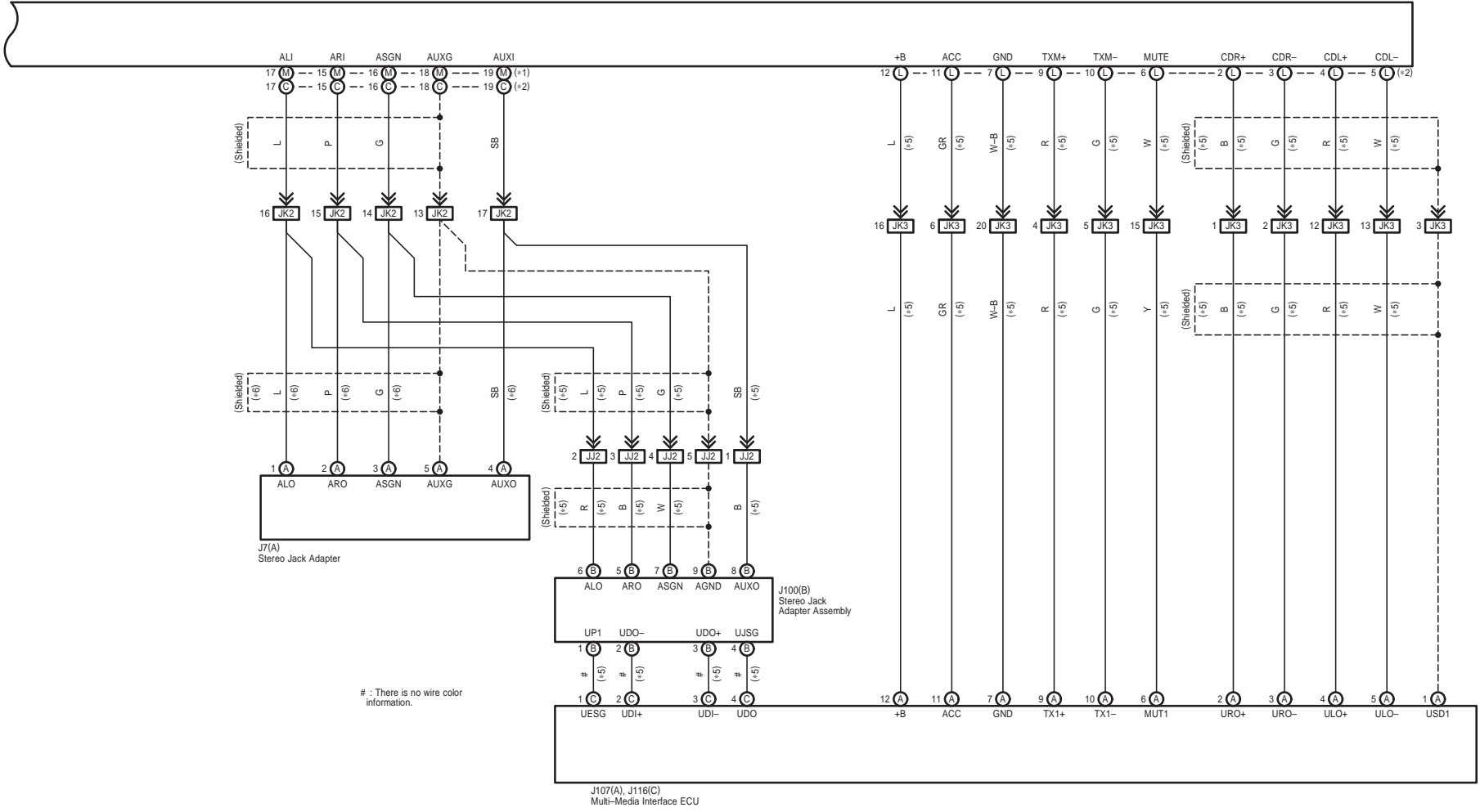

TOYOTA TUNDRA (EM16G1U)





Air Conditioning

\* 1 : Automatic A/C

TOYOTA TUNDRA (EM16G1U)

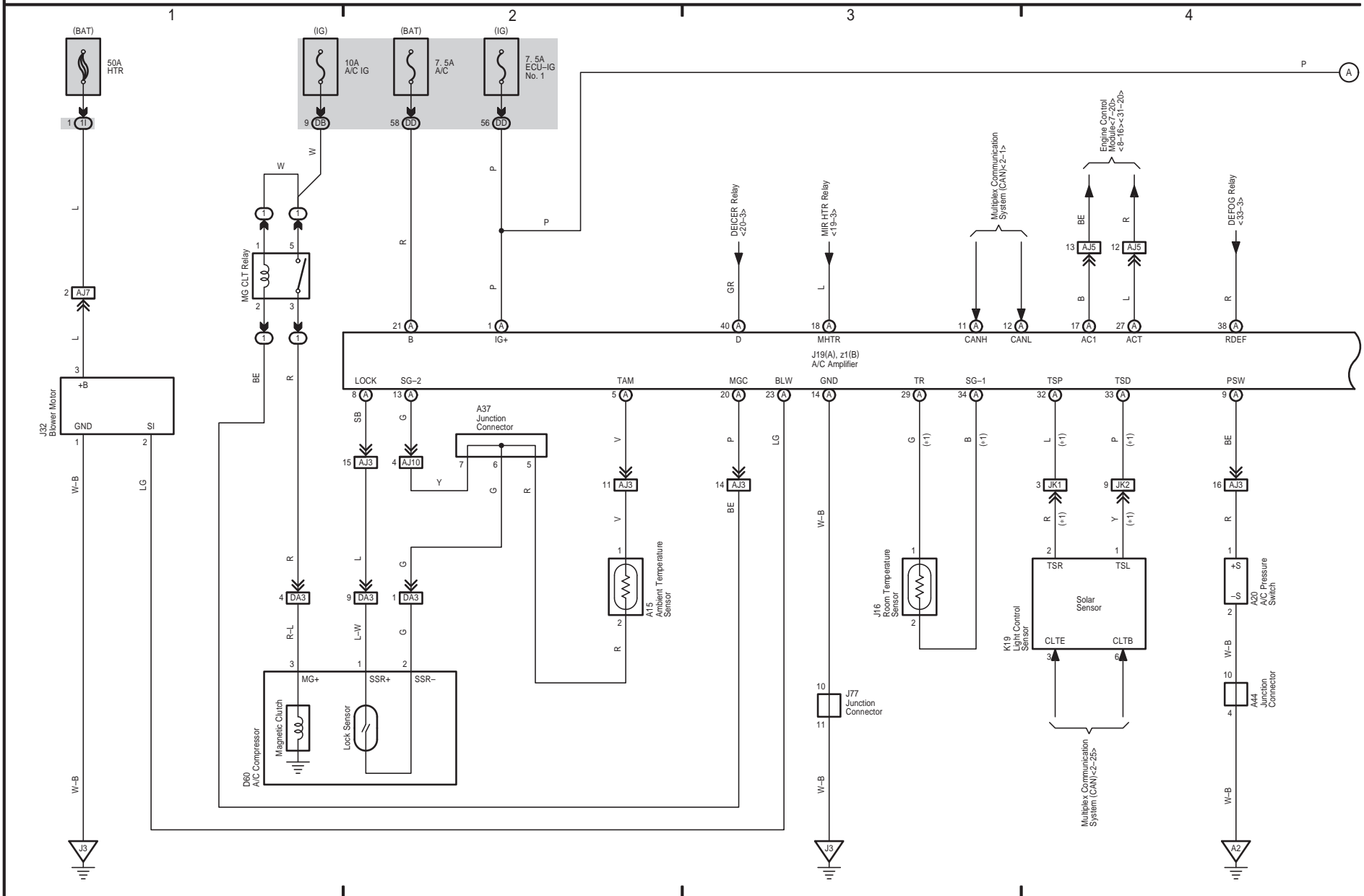

M OVERALL ELECTRICAL WIRING DIAGRAM

Air Conditioning

\* 1 : Automatic A/C

TOYOTA TUNDRA (EM16G1U)

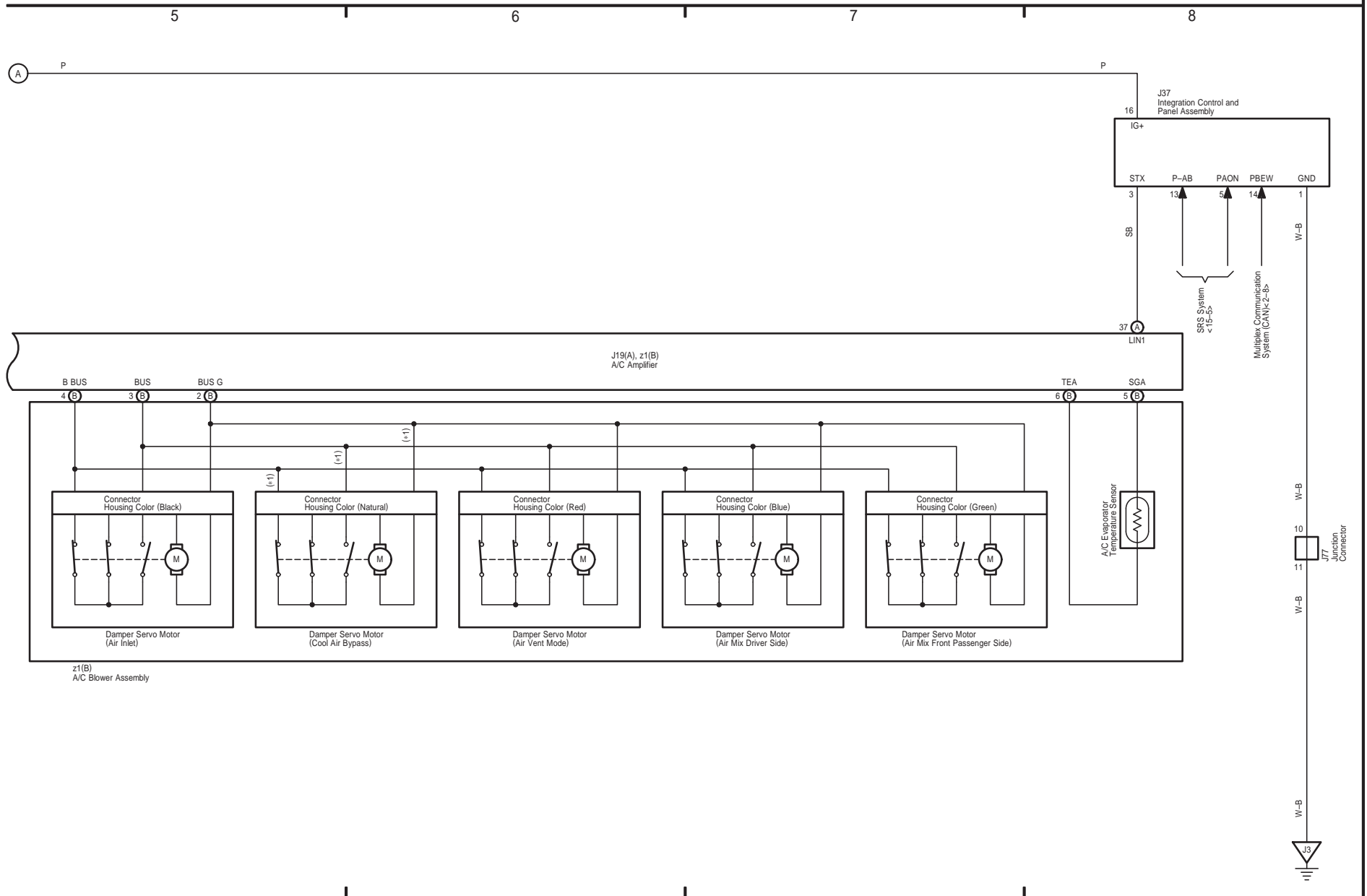



Engine Control (3UR-FE, 3UR-FBE)

\* 6 : 3UR-FE  
\* 7 : 3UR-FBE

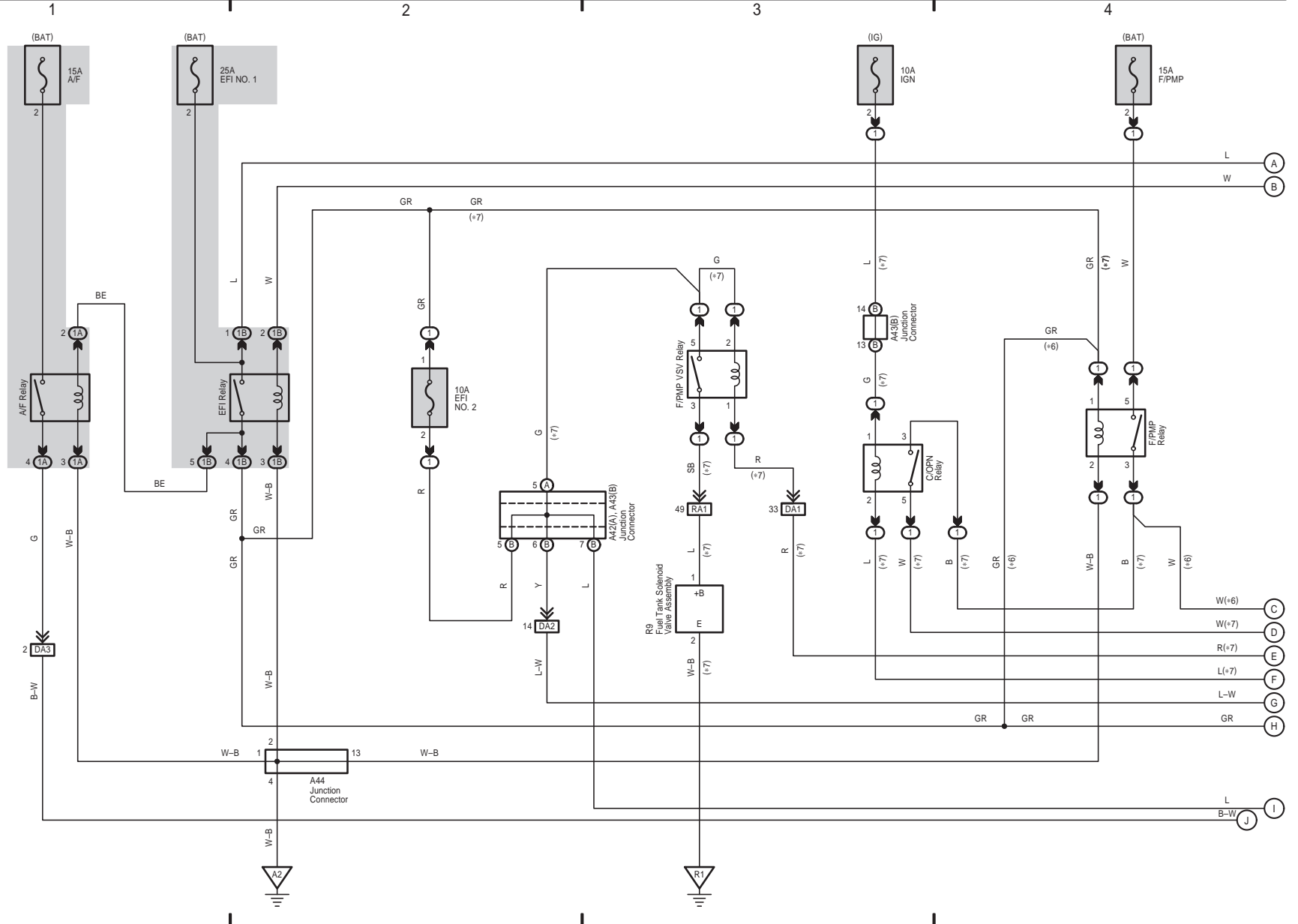

TOYOTA TUNDRA (EM16G1U)

M OVERALL ELECTRICAL WIRING DIAGRAM

Engine Control (3UR-FE, 3UR-FBE)

\* 6 : 3UR-FE  
 \* 7 : 3UR-FBE

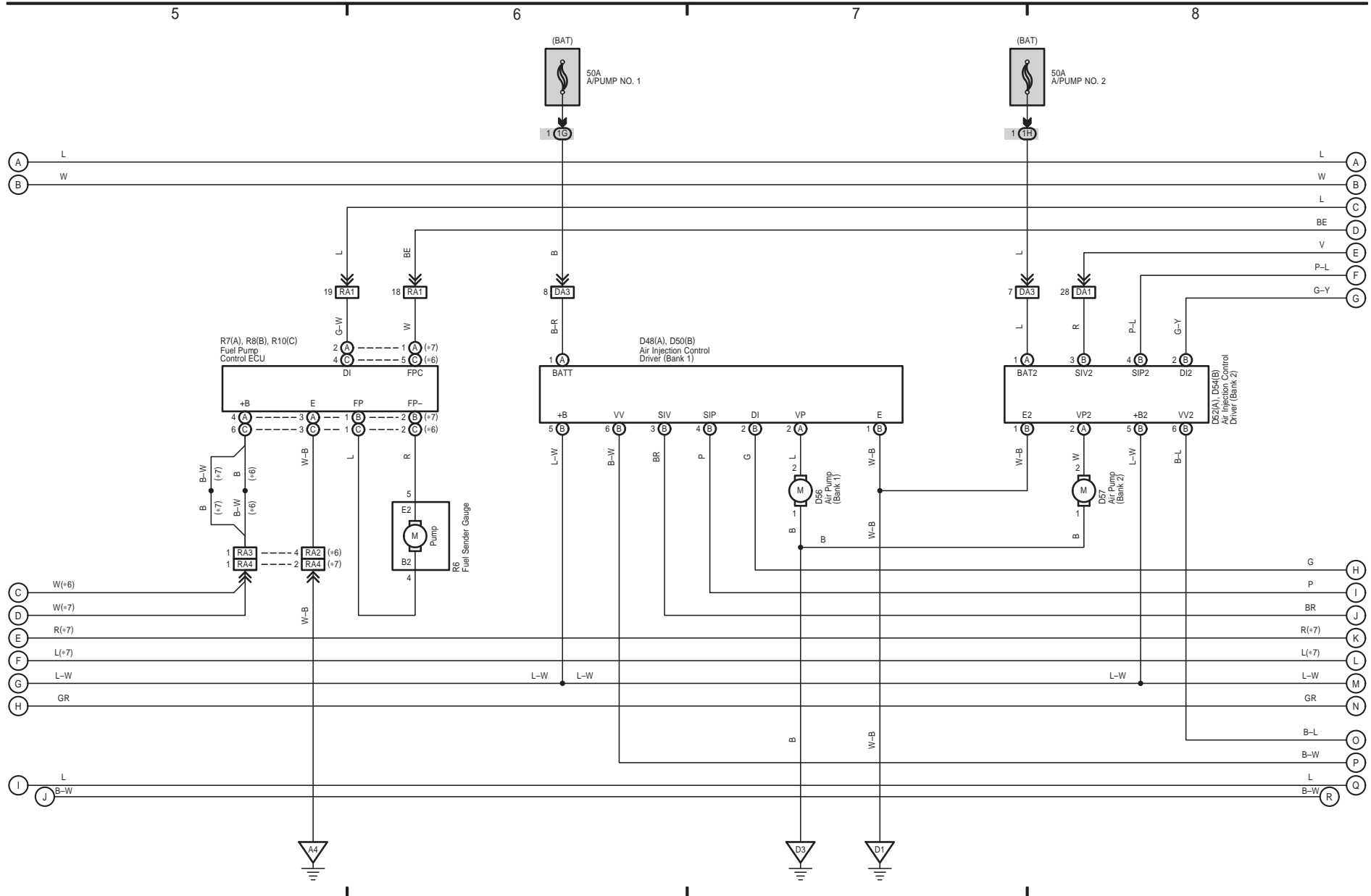

TOYOTA TUNDRA (EM16G1U)



Engine Control (3UR-FE, 3UR-FBE)

\* 7 : 3UR-FBE

TOYOTA TUNDRA (EM16G1U)

M OVERALL ELECTRICAL WIRING DIAGRAM

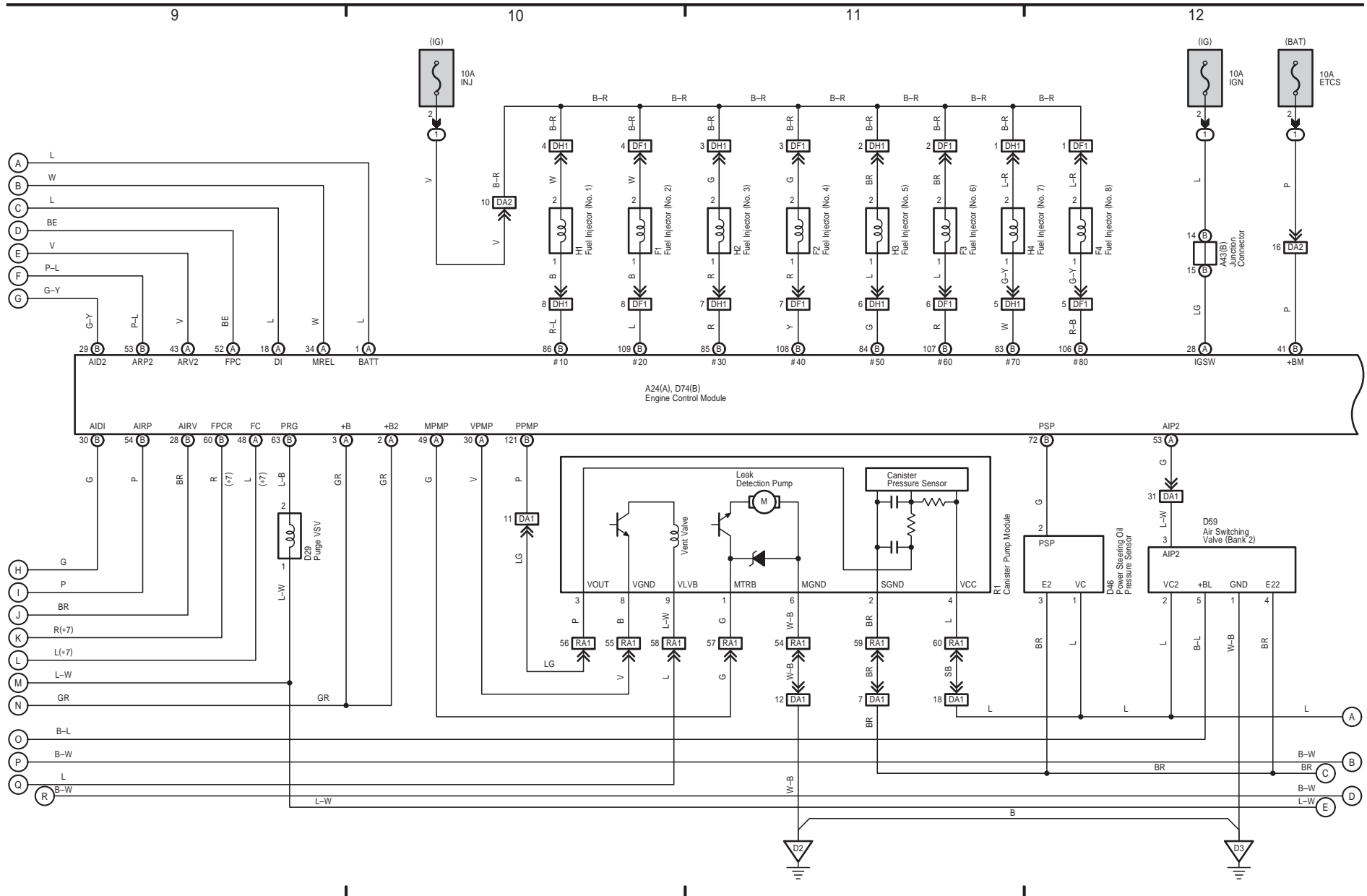

Engine Control (3UR-FE, 3UR-FBE)

\* 1 : Shielded

13

14

15

16

TOYOTA TUNDRA (EM16G1U)

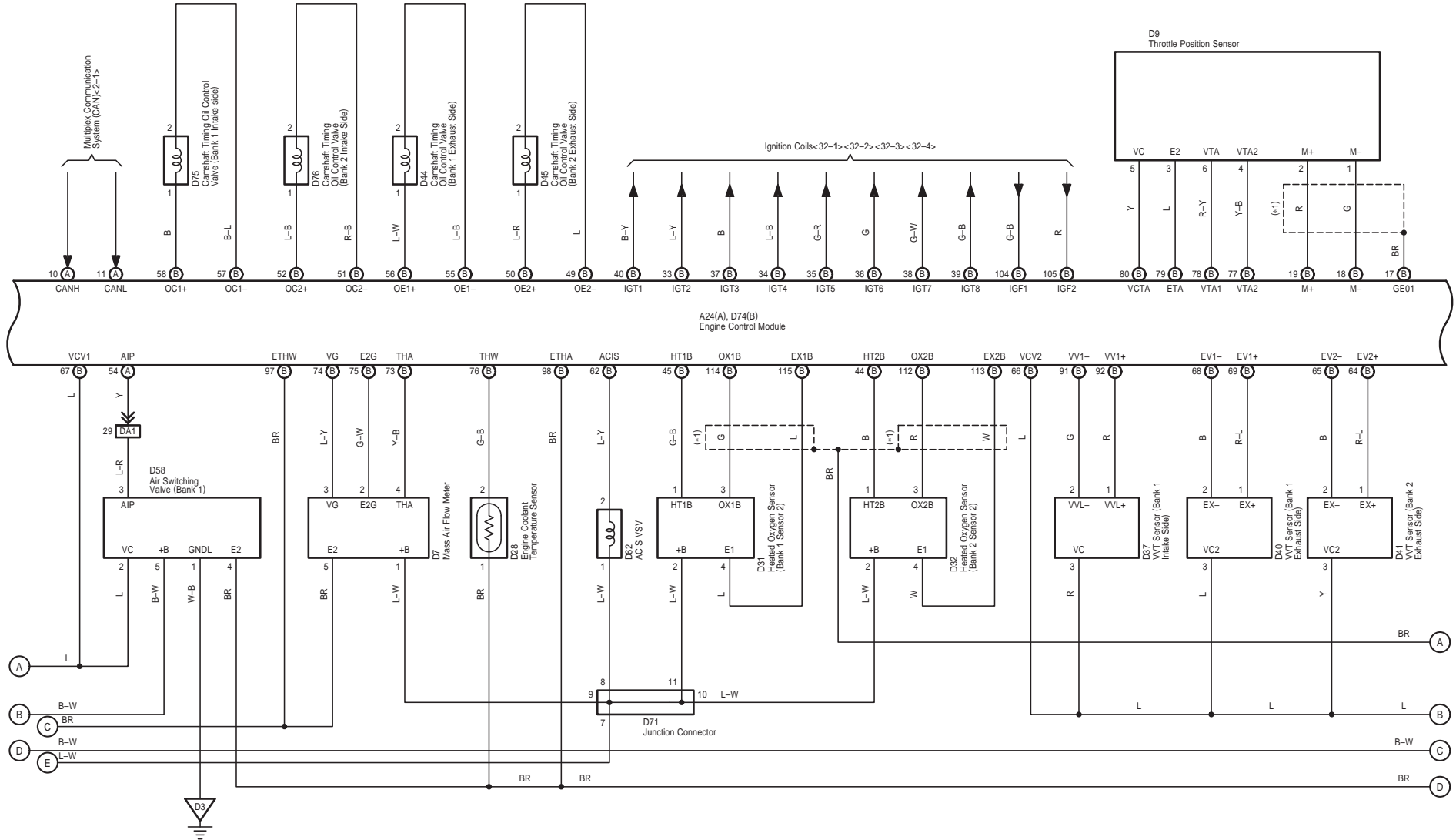

Engine Control (3UR-FE, 3UR-FBE)

\* 1 : Shielded

17

18

19

20

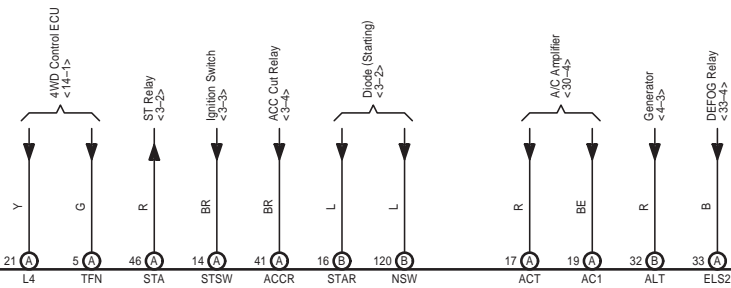
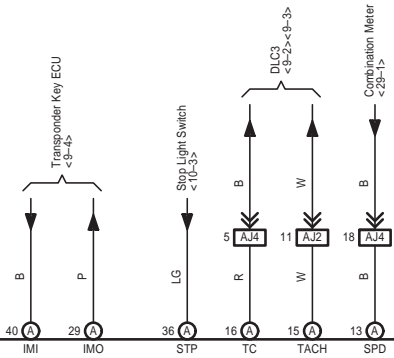
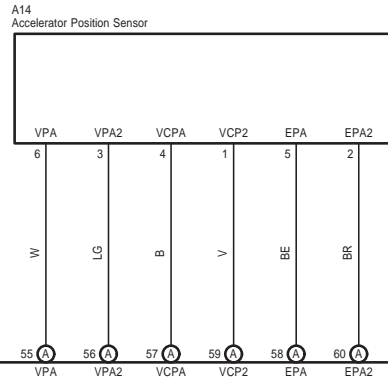

A24(A), D74(B) Engine Control Module

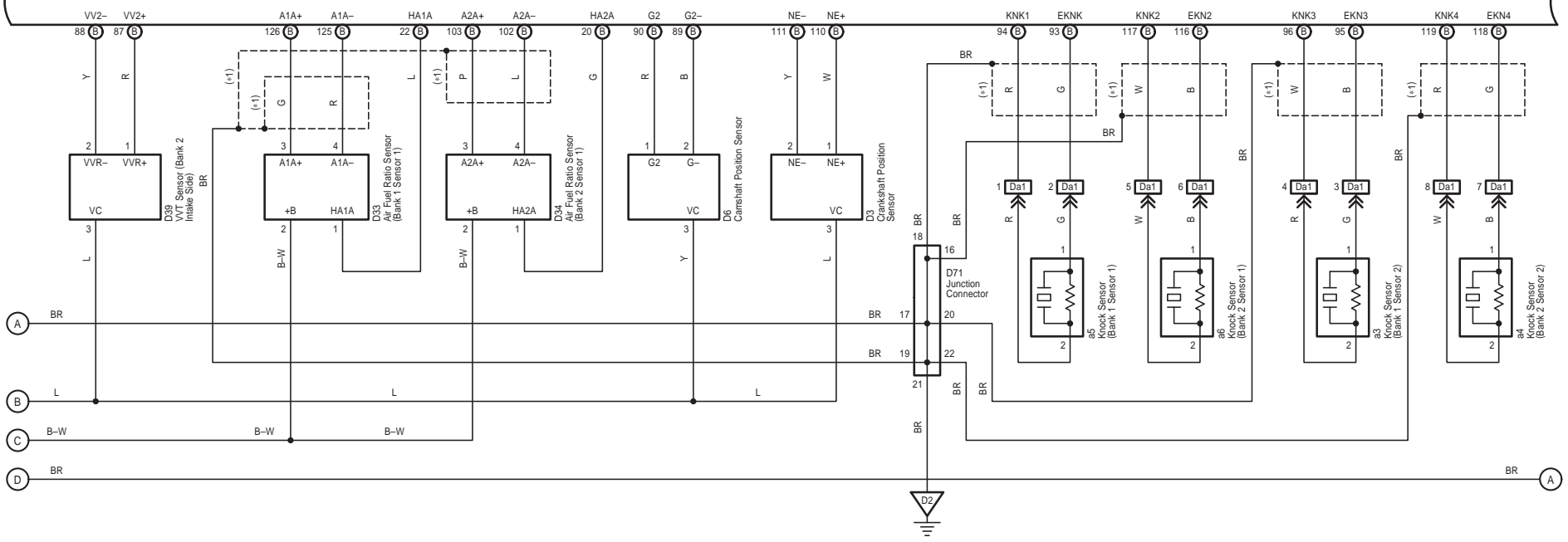

TOYOTA TUNDRA (EM16G1U)

M OVERALL ELECTRICAL WIRING DIAGRAM

Cruise Control (3UR-FE, 3UR-FBE)

21

22

23

24

TOYOTA TUNDRA (EM16G1U)

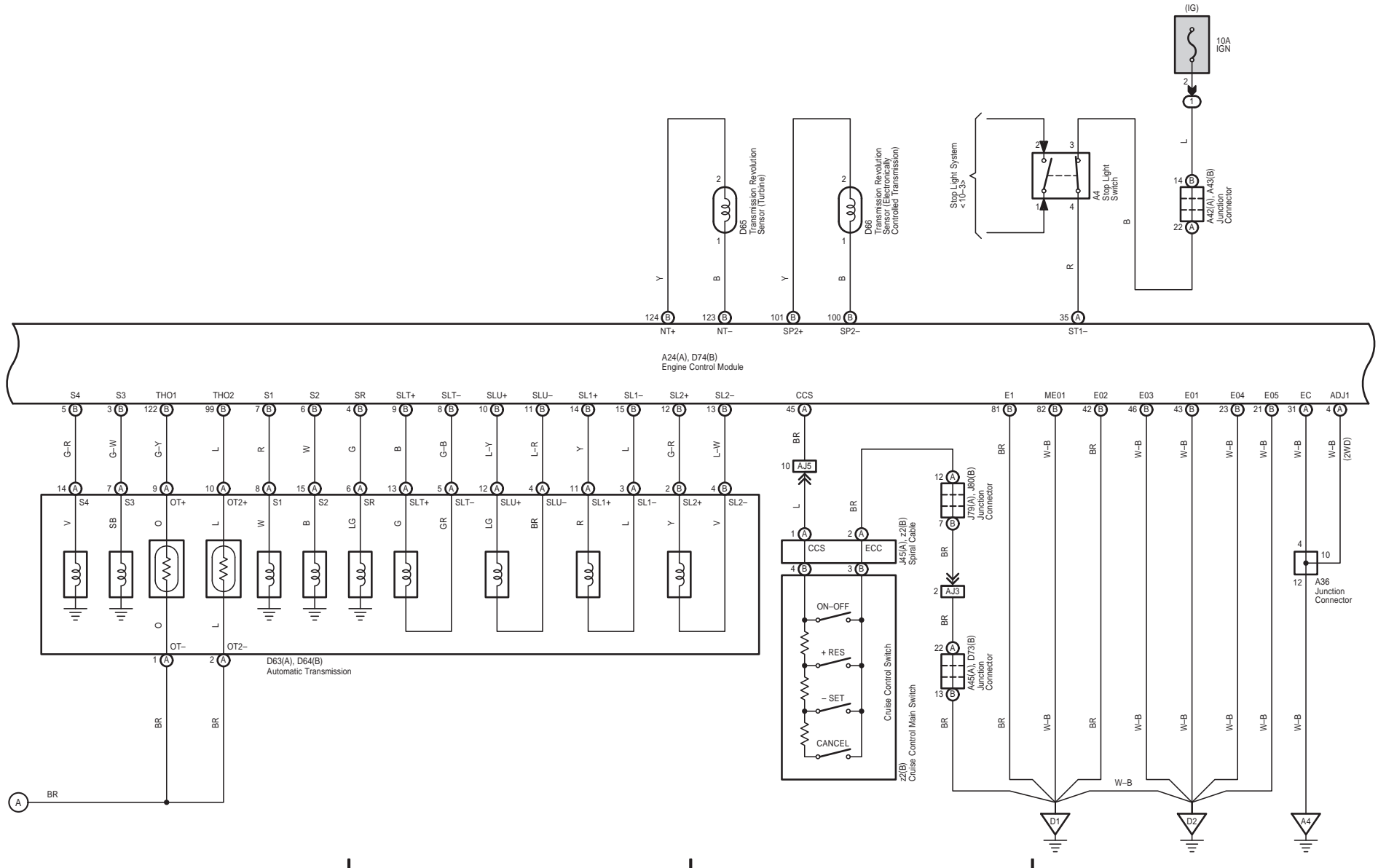

Electronically Controlled Transmission and A/T Indicator (3UR-FE, 3UR-FBE)

\* 2 : Floor Shift  
\* 3 : Column Shift

25

26

27

28

TOYOTA TUNDRA (EM16G1U)

M OVERALL ELECTRICAL WIRING DIAGRAM

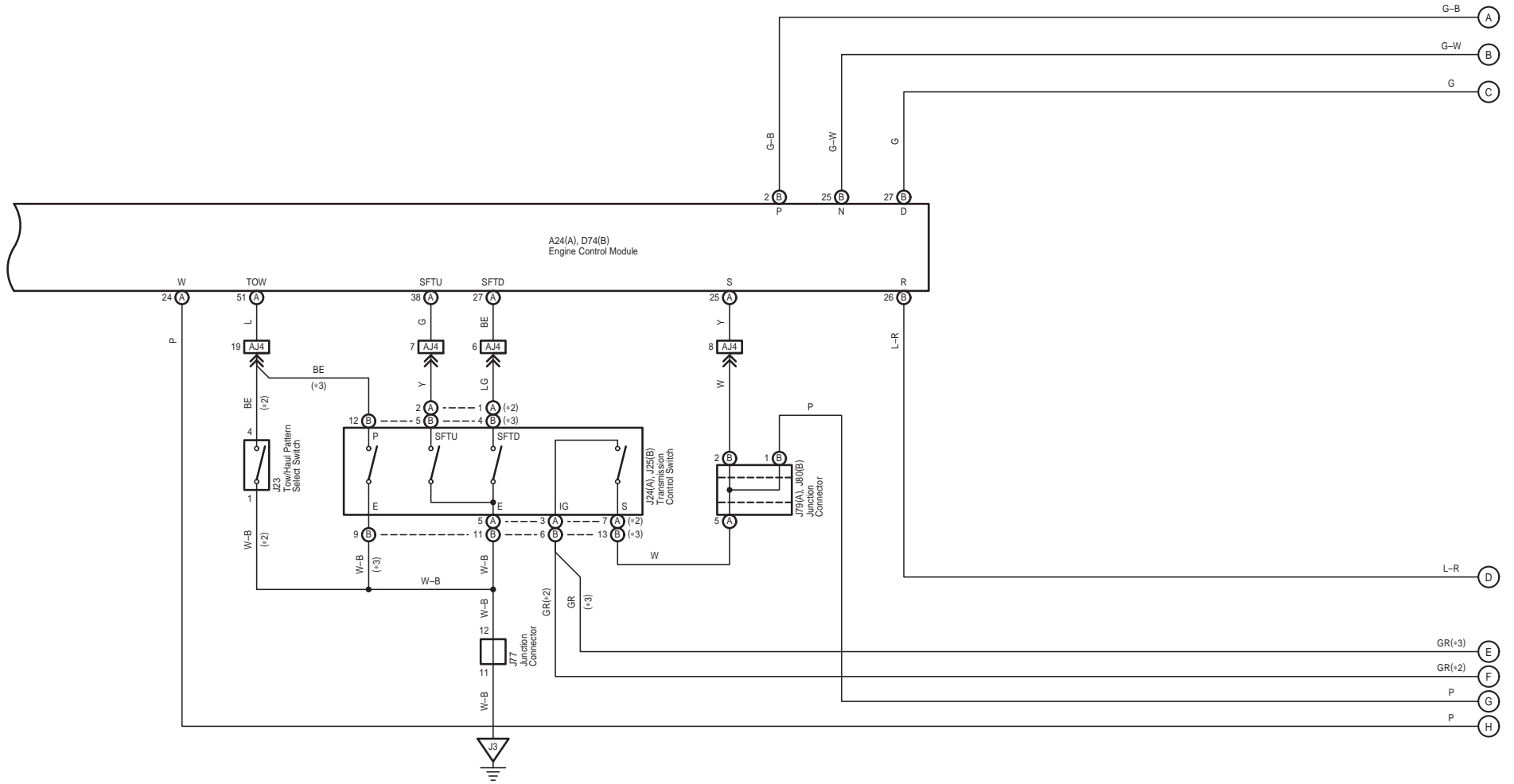

G-B (A)

G-W (B)

G (C)

L-R (D)

GR(+3) (E)

GR(+2) (F)

P (G)

P (H)

Electronically Controlled Transmission and A/T Indicator (3UR-FE, 3UR-FBE)

+ 2 : Floor Shift  
+ 3 : Column Shift

TOYOTA TUNDRA (EM16G1U)

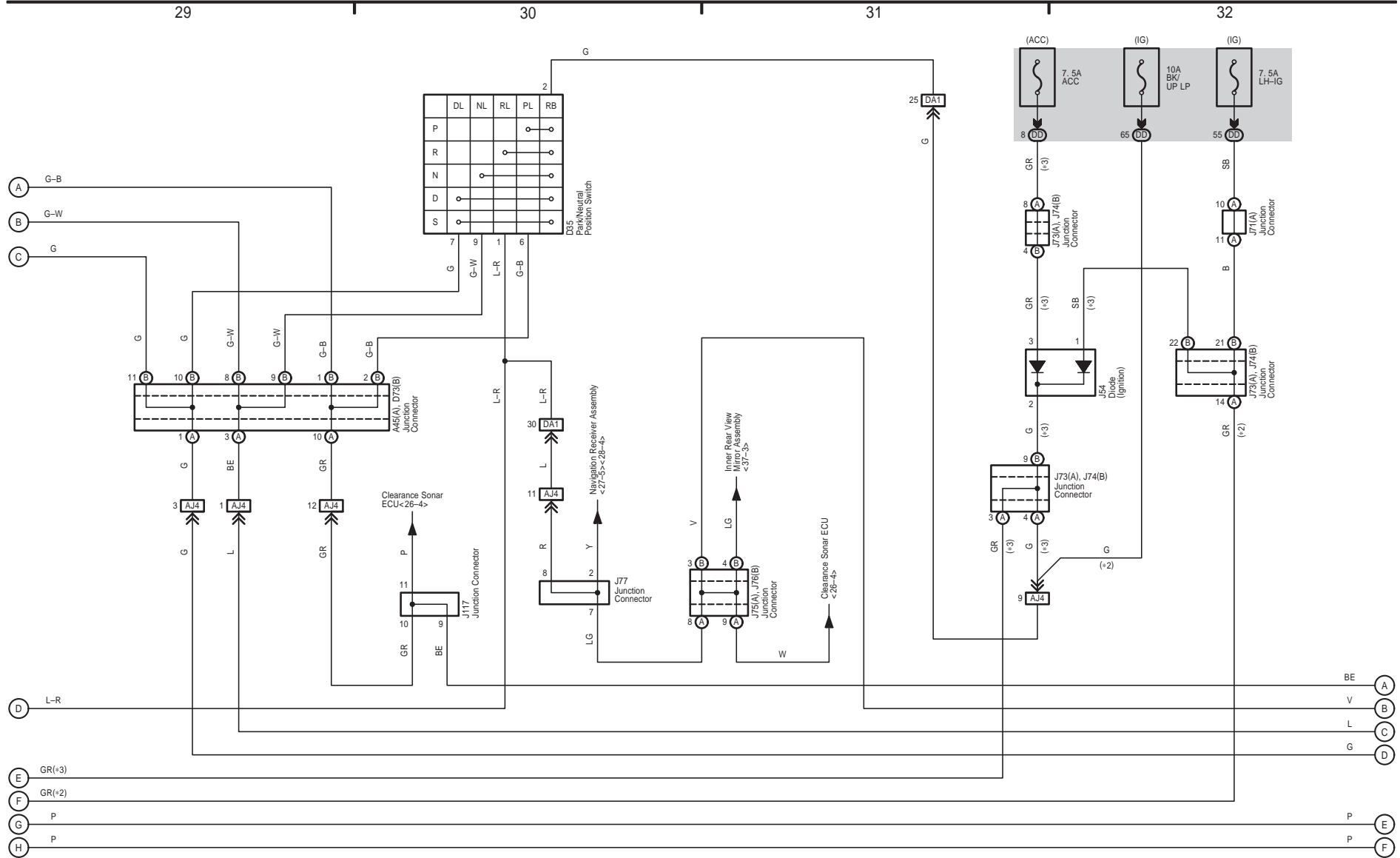



Electronically Controlled Transmission and A/T Indicator (3UR-FE, 3UR-FBE)

+ 4 : Optitron Meter  
 + 5 : Except Optitron Meter

TOYOTA TUNDRA (EM16G1U)

M OVERALL ELECTRICAL WIRING DIAGRAM

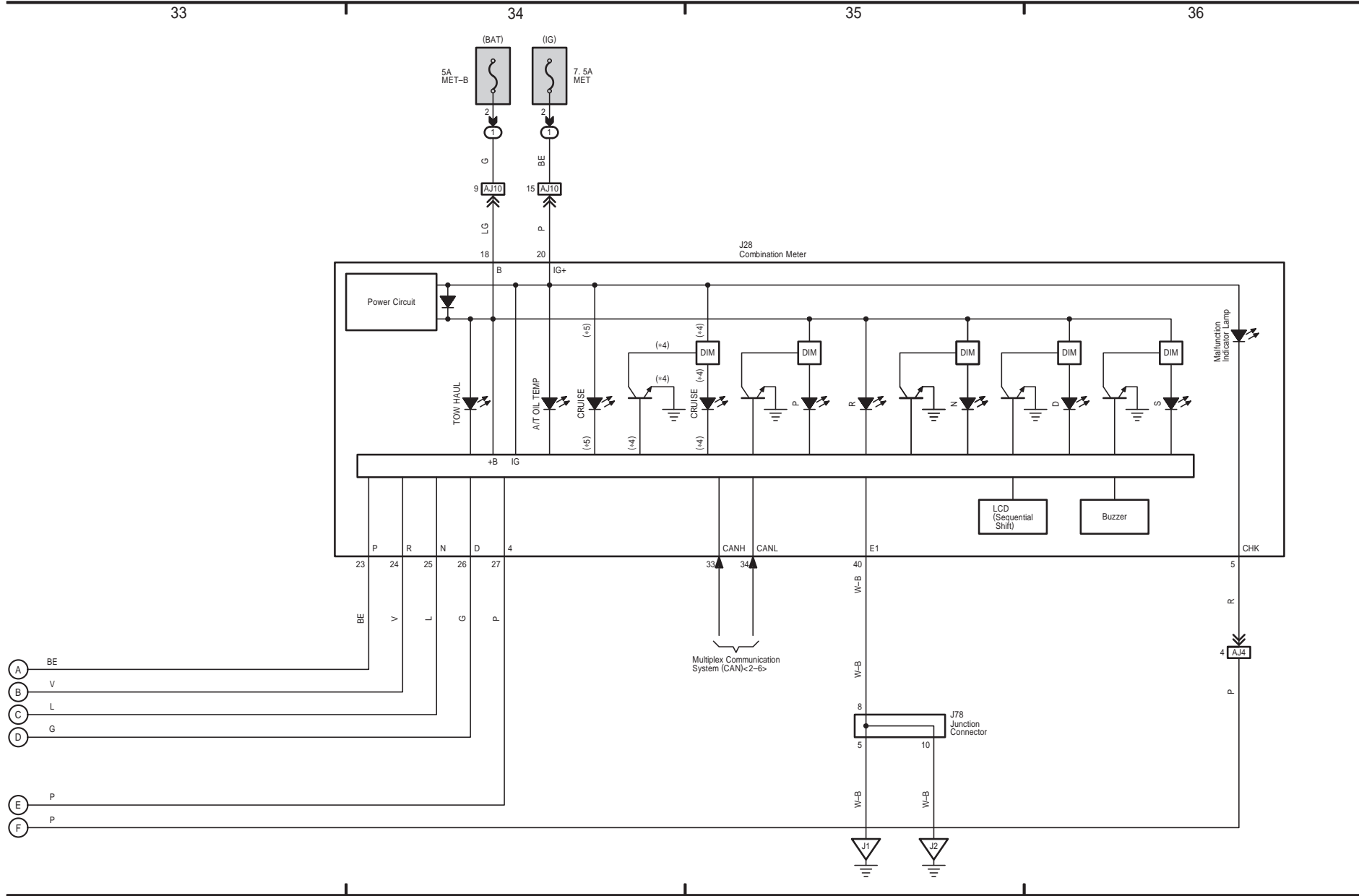

Ignition (3UR-FE, 3UR-FBE)

TOYOTA TUNDRA (EM16G1U)

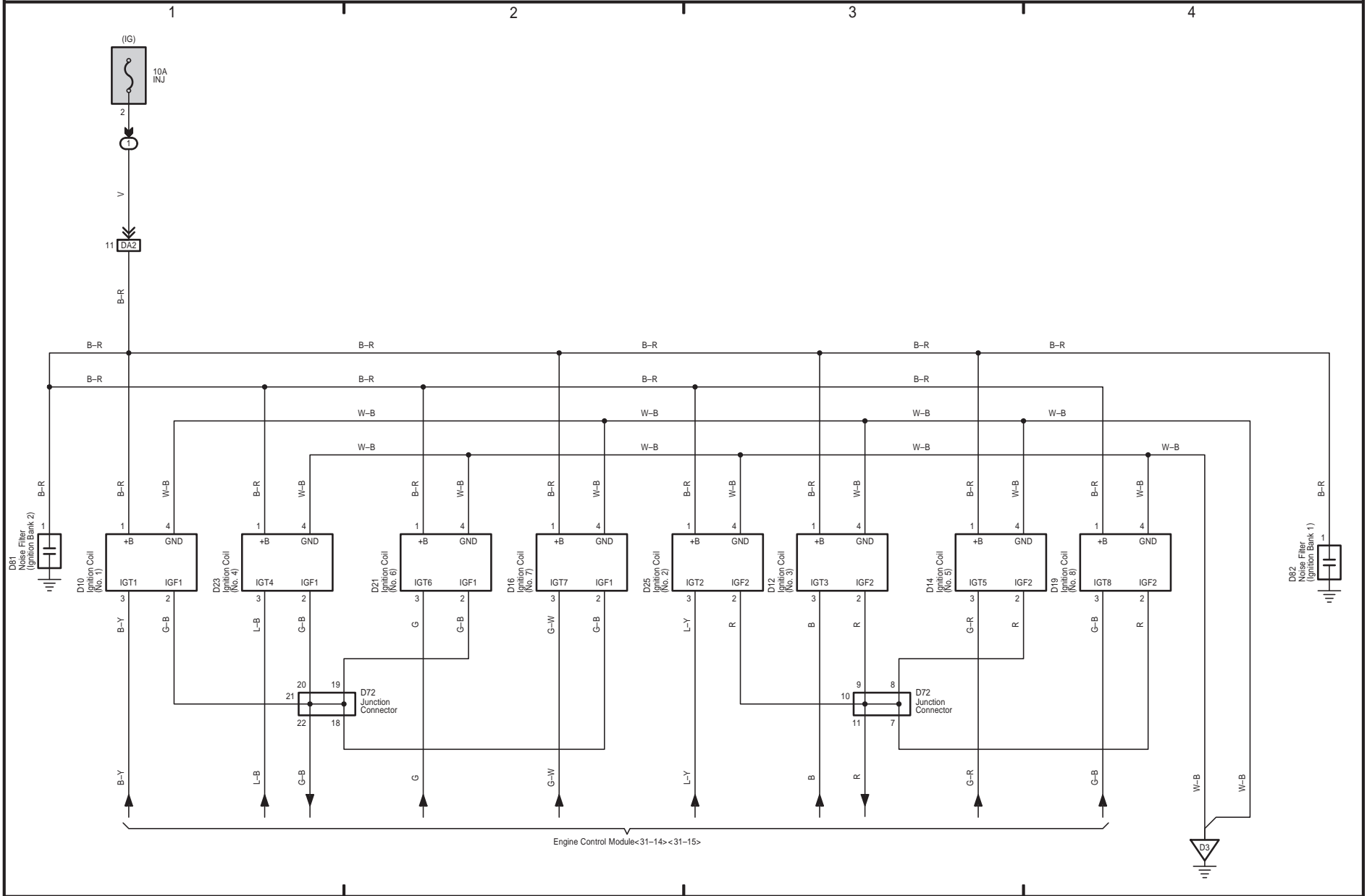

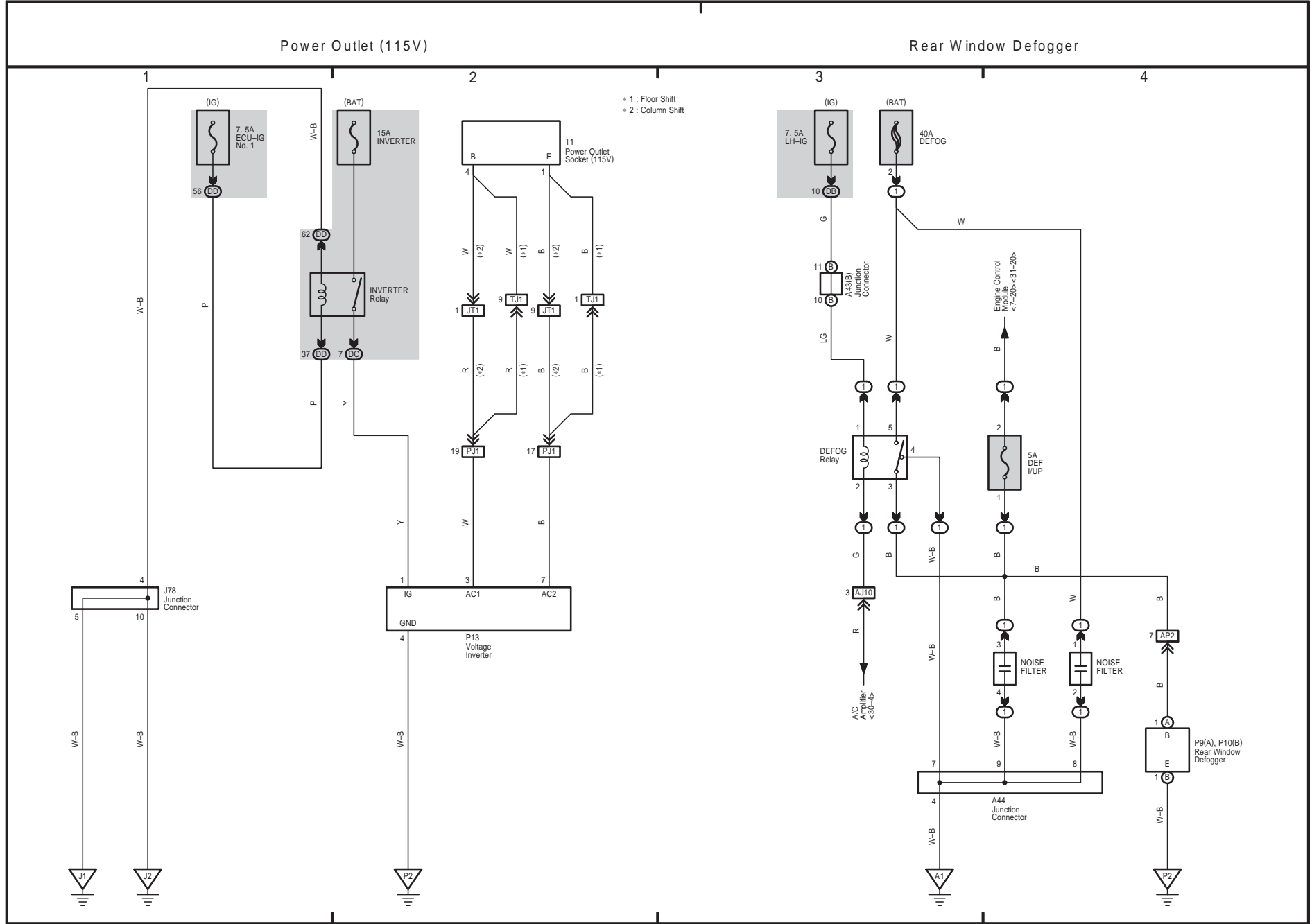

Headlight Beam Level Control

1 2 3 4

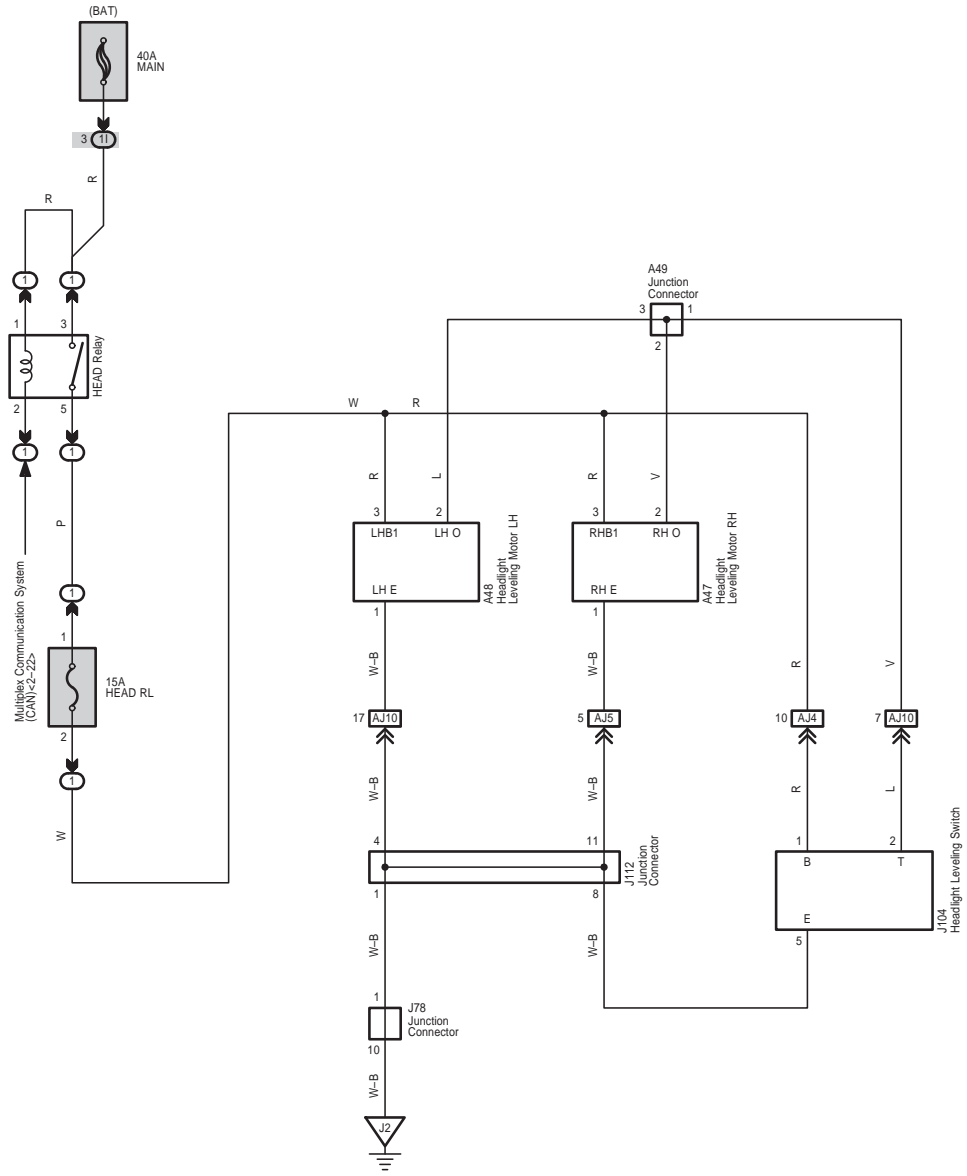

TOYOTA TUNDRA (EM16G1U)

Power Steering

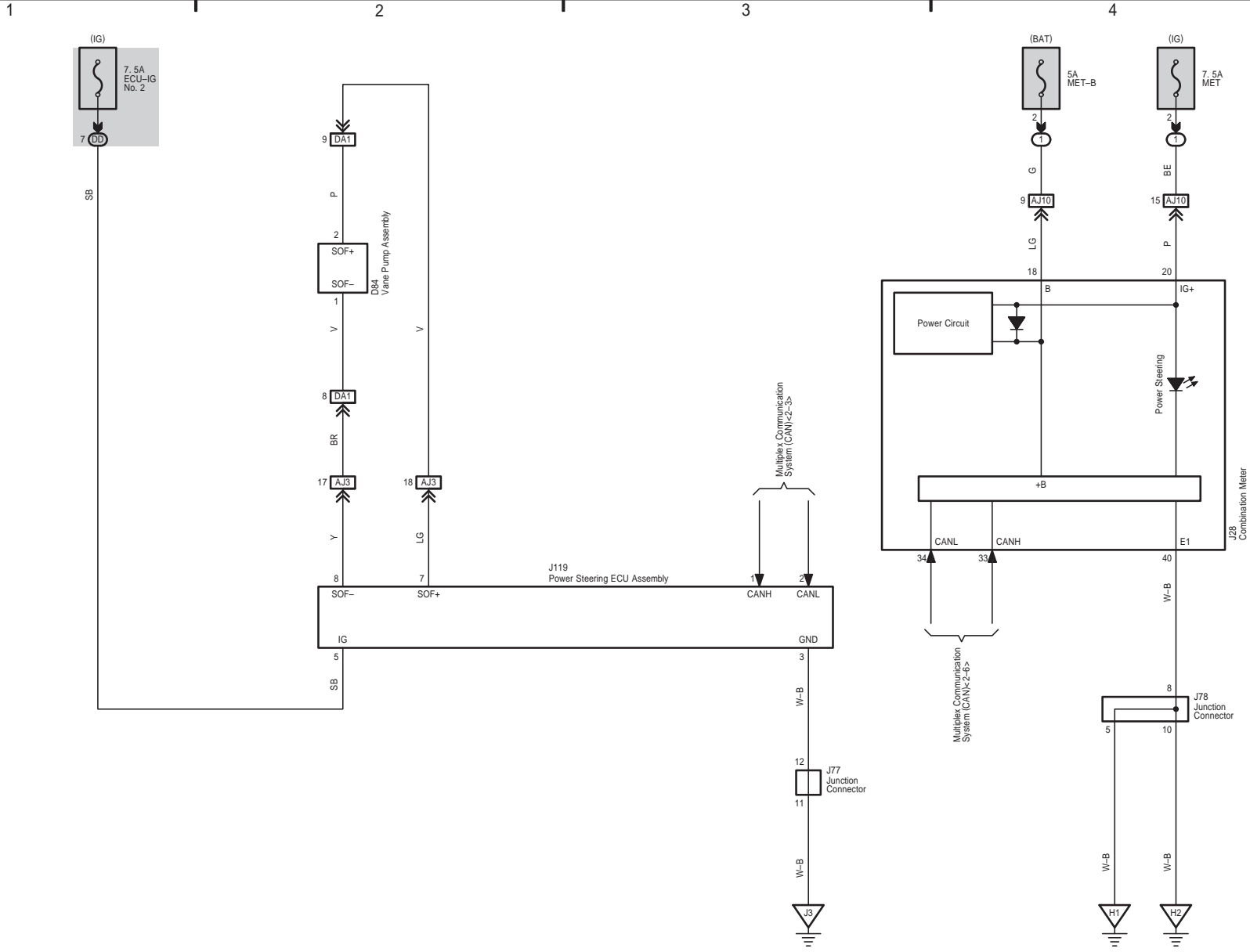

Climate Control Seat and Seat Heater (w/ Climate Control Seat)

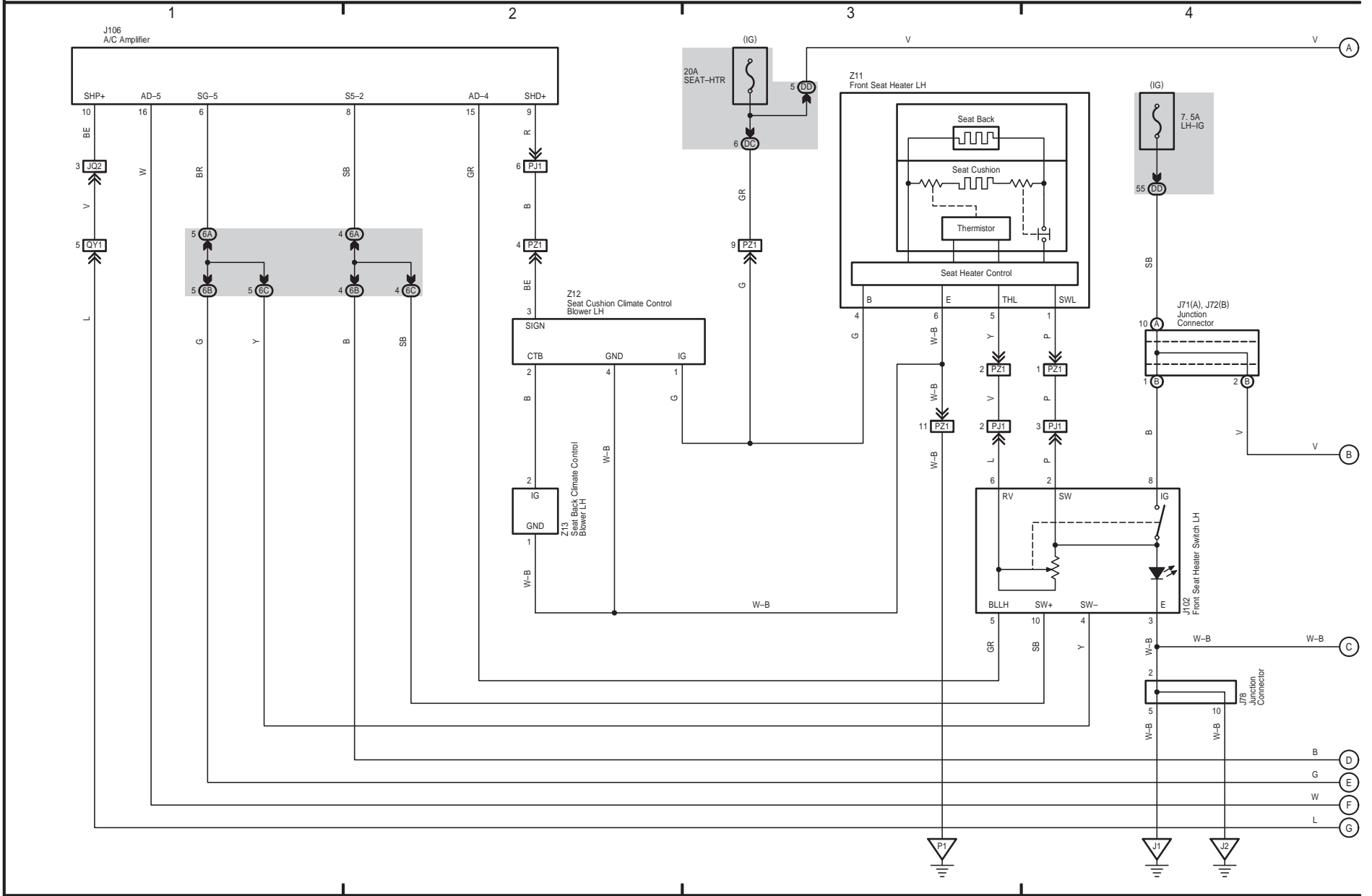

Climate Control Seat and Seat Heater (w/ Climate Control Seat)

5 6 7 8

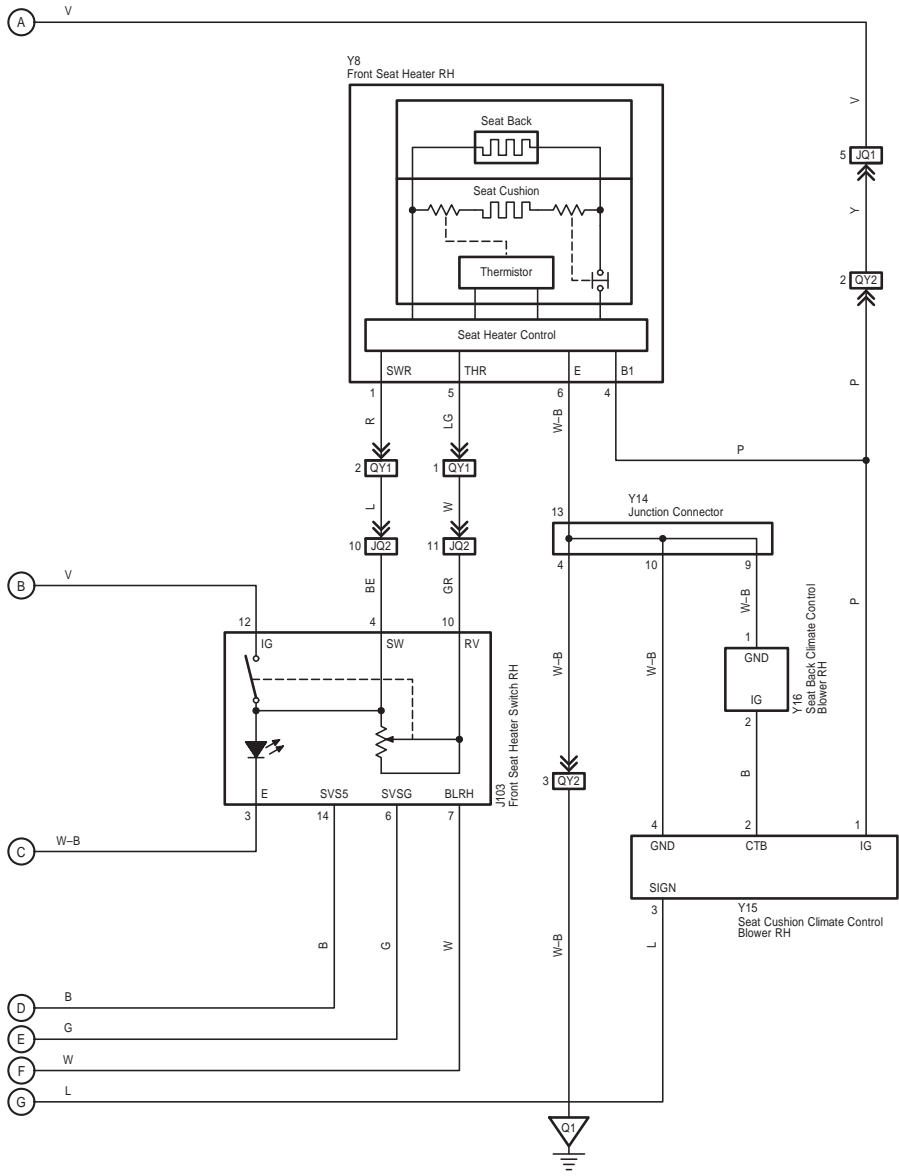

TOYOTA TUNDRA (EM16G1U)

Parking Assist (Rear View Monitor w/o Navigation System)

